

Introduction (Ask a Question)

Dynamic Reconfiguration Interface (DRI) SgCore IP is an embedded bus within the PolarFire® family of FPGAs. This user guide describes how DRI is used in PolarFire family. The FPGA fabric is common to the PolarFire family, which consists of the following FPGA devices.

- PolarFire FPGAs** Microchip's PolarFire® FPGAs are the fifth-generation family of non-volatile FPGA devices, built on state-of-the-art 28 nm non-volatile process technology. PolarFire FPGAs deliver the lowest power at mid-range densities. PolarFire FPGAs lower the cost of mid-range FPGAs by integrating the industry's lowest power FPGA fabric, lowest power 12.7 Gbps transceiver lane, built-in low power dual PCI Express® Gen2 (EP/RP), and, on select data security (S) devices, an integrated low-power crypto co-processor.
- PolarFire SoC FPGAs** Microchip's PolarFire SoC FPGAs are the fifth-generation family of non-volatile SoC FPGA devices, built on state-of-the-art 28 nm non-volatile process technology. The PolarFire SoC family offers industry's first RISC-V based SoC FPGAs capable of running Linux®. It combines a powerful 64-bit 5x core RISC-V Microprocessor Subsystem (MSS), based on SiFive's U54-MC family, with the PolarFire FPGA fabric in a single device.
- RT PolarFire FPGAs** Microchip's RT PolarFire® FPGAs combine our 60 years of space flight heritage with the industry's lowest-power PolarFire FPGA family to enable new capabilities for space and mission-critical applications. RT PolarFire FPGA family includes RTPF500T, RTPF500TL, RTPF500TS, RTPF500TLS, RTPF500ZT, RTPF500ZTL, RTPF500ZTS, and RTPF500ZTLS devices.

DRI is an APB target interconnect providing global access to the following embedded blocks:

- Transceiver lanes
- Transmit PLLs
- PLLs/DLLs (Clock Conditioning Circuitry or CCCs)

DRI allows modification of these embedded blocks at power-up and during operation. The embedded DRI bus provides dedicated connectivity and register mapped addressing to all the features as APB target peripherals. The DRI connectivity is a fixed dedicated resource that does not require any fabric logic or routing resources. Each transceiver and CCC supports a DRI, which can be enabled to configure its parameters without reprogramming the device. The transceiver, PCIESS, and CCC reconfiguration is controlled by volatile configuration registers that are loaded with values from the Flash configuration bits at power-up. It is recommended to carefully use DRI because changing the factory or initialization settings can cause undesired results.



Important:

- AXI and APB protocol standards use the terminology "Manager" and "Subordinate". The equivalent Microchip terminology used in this document is "Initiator" and "Target" respectively.
- DRI is not available to the user logic, when SmartDebug is being used for debugging.

The following table summarizes DRI access in the PolarFire family.

Table 1. PolarFire® Family DRI

DRI Access	PolarFire®	RT PolarFire	PolarFire SoC	Description
PF_DRI SgCore IP	✓	✓	✓	<p>The PF_DRI IP enables user access to the embedded APB target bus which provides a mirrored initiator APB target interface to the FPGA fabric. This IP can be seamlessly used in the PolarFire Family.</p> <p>In PolarFire and RT PolarFire designs, the APB initiator can be implemented with the Mi-V soft processor IP or the CoreABC IP for controlling and accessing the DRI target peripherals.</p> <p>In PolarFire SoC designs, the APB initiator can be implemented with the PolarFire SoC MSS, the Mi-V soft processor IP, or the CoreABC IP for controlling and accessing the DRI target peripherals.</p>

Table of Contents

Introduction.....	1
1. DRI Use Model.....	4
1.1. PolarFire and RT PolarFire FPGA.....	4
1.2. PolarFire SoC FPGA.....	6
2. Design Initialization Data Report.....	7
3. PF_DRI SgCore IP.....	8
3.1. DRI Configuration for XCVR.....	9
3.2. DRI Configuration for TX PLL.....	10
3.3. DRI Configuration for PCIE.....	11
3.4. DRI Configuration for CCC.....	12
3.5. Misc Tab.....	14
4. Functional Timing Diagram.....	16
5. Revision History.....	17
Microchip FPGA Support.....	18
Microchip Information.....	18
The Microchip Website.....	18
Product Change Notification Service.....	18
Customer Support.....	18
Microchip Devices Code Protection Feature.....	18
Legal Notice.....	19
Trademarks.....	19
Quality Management System.....	20
Worldwide Sales and Service.....	21

1. DRI Use Model [\(Ask a Question\)](#)

The following sections describe the DRI use models in the PolarFire family.

- [PolarFire and RT PolarFire FPGA](#)
- [PolarFire SoC FPGA](#)

1.1 PolarFire and RT PolarFire FPGA [\(Ask a Question\)](#)

The following figure shows the high-level block diagram of the DRI use model in PolarFire and RT PolarFire devices.

Figure 1-1. High-Level Block Diagram of DRI Implementation

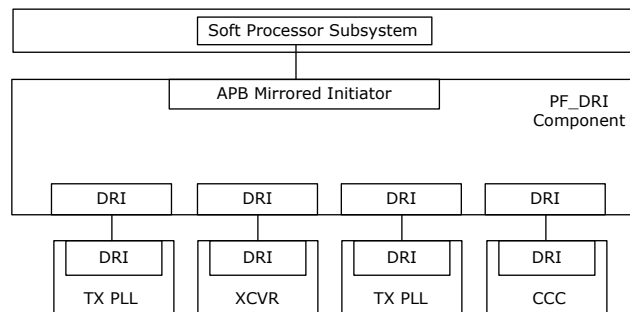

For more information about the PolarFire register map, see [PolarFire Device Register Map](#).

For information about the dynamic reconfiguration of transceiver and CCC using the PF_DRI IP, see [AN4592: PolarFire FPGA Dynamic Reconfiguration Interface Application Note \(Earlier AC475\)](#).



Important: Consider the following key points while accessing DRI:

- The DRI registers of peripheral blocks can be accessed through the APB interface using Mi-V soft processor, CoreABC, External processor, or Fabric state machine.
- The minimum address space required for accessing all the DRI registers through APB is 256 MB.
- The base address for accessing the DRI register is ($ADDR_{slave_targets} + ADDR_{peripheral}$). Where,
 - $ADDR_{slave_targets}$ denotes the address of the slave target connected to the soft processor. The APB slave is connected to the soft processor (Mi-V or CoreABC) through the CoreAHBLite IP.
 - $ADDR_{peripheral}$ denotes the address of the peripheral connected to the CoreAPB3 IP.
- As an example, suppose that Mi-V soft processor is used to access the DRI registers of the south-west CCC. Since these CCC registers are accessed through the APB interface, the base address for the CCC registers becomes 0x6840 0000 (0x6000 0000 + 0x0840 0000). Where,
 - 0x6000 0000 is the APB address connected to the Mi-V soft processor
 - 0x0840 0000 is the address offset of the south-west CCC per [PolarFire Device Register Map](#).
- The DRI_PCLK must be gated off until a valid source clock is present and device initialization is completed. It is recommended to use an $RGCLKINT$ macro to gate this clock. The gate enable signal must be qualified by the $DEVICE_INIT_DONE$ and $AUTO_CALIB_DONE$ outputs of the $PF_INIT_MONITOR$ IP. Additionally, the gate must be qualified with any signals available that indicate the DRI_PCLK sourcing clock is stable (for example, PLL_LOCK and $BANK_x_VDDI_STATUS$).

1.2 PolarFire SoC FPGA (Ask a Question)

The following figure shows the high-level block diagram of the DRI use model in PolarFire SoC devices. In PolarFire SoC FPGAs, MSS accesses the PF_DRI IP via FIC_3 which is an APB interface.

Figure 1-2. DRI Accessed Using PF_DRI IP from Fabric

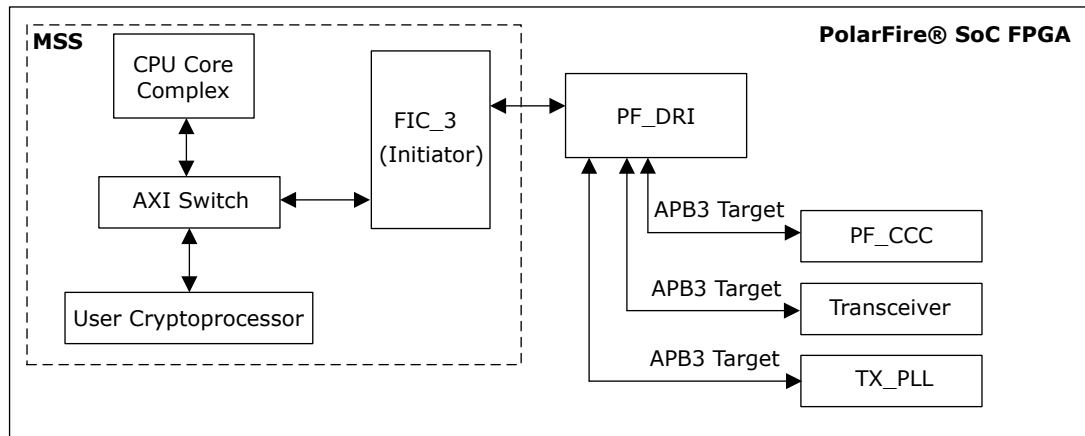

➔ Important: Consider the following key points while accessing DRI:

- One of the processor cores is used to update the DRI registers of peripheral blocks through the FIC3 (0x4000_0000). Therefore, the base address for accessing the DRI register is $(0x4000_0000 + ADDR_{\text{peripheral}})$. Where, $ADDR_{\text{peripheral}}$ denotes the address of the peripheral whose DRI register must be accessed.
 - For example, the address offset for the south-west CCC registers starts at 0x08400000 as per [PolarFire SoC Device Register Map](#). Since these CCC registers are accessed through FIC3, the base address for the CCC registers becomes 0x4840 0000 $(0x4000\ 0000 + 0x0840\ 0000)$.
-
- For more information about PolarFire SoC MSS, see [PolarFire SoC FPGA MSS Technical Reference Manual](#). For more information about configuring PolarFire SoC MSS, see [Standalone MSS Configurator User Guide for PolarFire SoC](#).
 - For more information about the PolarFire SoC register map, see [PolarFire SoC Device Register Map](#).
 - For more information about updating the CCC PLL outputs dynamically using the PF_DRI IP, see [PolarFire SoC Bare Metal DRI Application](#). The DRI application is available at `baremetal_applications/DRI` directory of the `apps` repository.

2. Design Initialization Data Report [\(Ask a Question\)](#)

The `Design_Initialization_Data_Report.xml` report file includes the register configuration values of CCC, XCVR, and TXPLL used in a design. This report is generated after the completion of the **Generate Design Initialization Data** step of the Libero® SoC design flow. For more information, see [Libero SoC Design Flow User Guide](#).

To view the `Design_Initialization_Data_Report.xml` report file, right click **Generate Design Initialization Data** from Libero Design Flow and select **View Report**.

After knowing these values, you can build another design for comparing the changes in the register values required to dynamically change the data or clock rate using DRI. The following figure shows the `Design_Initialization_Data_Report.xml` report file from the **Reports** tab of Libero SoC.

Using this report, you can view the following:

- Addresses and values of `RXPLL_FBDIV` and `RXPLL_REFDIV` registers set by the XCVR configurator.
- Addresses and values of `PLL_DIV_0_1`, `PLL_DIV_2_3`, and `PLL_REF_FB` registers set by the CCC configurator.

Figure 2-1. Design Initialization Data Report

Power Up to Functional Timing (PUFT)

INFO: The PUFT timing numbers reflect the time elapsed between the assertion of FABRIC_POR_N signal and the assertion of each signal in the below table.

Signal Name	PUFT (micro secs)
SRAM_INIT_FROM_SNMV_DONE	3321.289
DEVICE_INIT_DONE	3336.289

PLL_SW_0 (PF_CCC_C0_0/PF_CCC_C0_0/pll_inst_0)

Register Name	Register Address	Register Reset	Register Configured Value	Register Modified	Lock Value(*)
SOFT_RESET	0x8400000	0x00000000	0x00000000	No	N/A
PLL_CTRL	0x8400004	0x0000107C	0x00001087	Yes	N/A
PLL_REF_FB	0x8400008	0x00000000	0x00000500	Yes	N/A
PLL_FRACN	0x840000C	0x00000000	0x00000000	No	N/A
PLL_DIV_0_1	0x8400010	0x00000000	0x01001300	Yes	N/A
PLL_DIV_2_3	0x8400014	0x00000000	0x01000100	Yes	N/A
PLL_CTRL2	0x8400018	0x00001006	0x0000101C	Yes	N/A
PLL_CAL	0x840001C	0x00000000	0x0000000E	Yes	N/A
PLL_PHADJ	0x8400020	0x00004001	0x00004000	Yes	N/A
SSCG_REG_0	0x8400024	0x00000000	0x00000001	Yes	N/A
SSCG_REG_1	0x8400028	0x00000000	0x0000000A	Yes	N/A
SSCG_REG_2	0x840002C	0x00000000	0x000001EE	Yes	N/A
SSCG_REG_3	0x8400030	0x00000000	0x00000001	Yes	N/A

Note: (*) Lock Value = 0, disables modification of the Register. Lock Value = N/A, locking does not apply to the Register.

Q4_TXPLL (Unused)



Important: The `.xml` and `.txt` files of this report can also be accessed from `<$Libero_Project_location>\designer\top`.

3. PF_DRI SgCore IP [\(Ask a Question\)](#)

The PF_DRI SgCore IP is available in the **Catalog** under **Peripherals**. If you do not see this core, download and install the MegaVault. For more information about downloading and installing the MegaVault, see [Libero Software Download and License Installation Quick Start Guide](#).

Figure 3-1. DRI IP with APB Interface

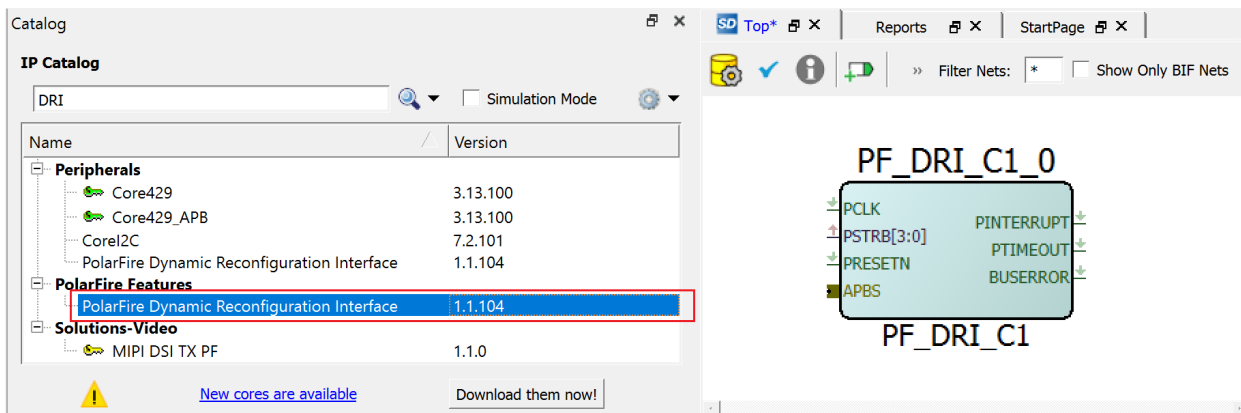

The following table lists the general ports of the PF_DRI SgCore.

Table 3-1. PF_DRI Ports

Port Name	Direction	Width	Description
PCLK	Input	1	Input clock source to DRI. This clock can be sourced from a CCC or an external oscillator. All transfers on the APB bus are clocked with respect to the rising edge of PCLK.
PSTRB[3:0]	Input	4	(Active-High) There is one write strobe for each byte of the write data (PWRITE 32-bit or 4 bytes). PSTRB signal indicates the byte lanes to be updated during a write transfer.
PRESETN	Input	1	(Active-Low) The APB Reset signal from the initiator.
PINTERRUPT	Output	1	(Active-High) Interrupt can be handled by a soft processor or can be handled by other user logic in the fabric. DRI_INTERRUPT is the source of the INTERRUPT.
PTIMEOUT	Output	1	(Active-High) Indicates to the fabric that the bus timed out (no response received). Time-out can occur when accessing a target that is not ready.
BUSERROR	Output	1	(Active-High) Indicates to the fabric that a bus error was detected. Once asserted, this error signal stays active until PRESETN is asserted. Bus error can occur if accessing locked or non-existent targets.

.....continued

Port Name	Direction	Width	Description
APBS (APB Bus Interface bus signals)	—	—	The APBS port is connected to APB initiator. For example, CoreABC/Mi-V Soft Processor.
PADDR (input)		29	This is the APB address bus driven by the initiator.
PENABLE (input)		1	(Active-High) Enable signal from the initiator to trigger APB transfer.
PRDATA (output)		32	The selected target drives this data to the initiator during read cycles when PWRITE is Low.
PREADY (output)		1	(Active-High) This signal indicates that APB bus is ready for transfer to target. When PREADY is Low, the target initiates a transfer to DRI.
PSEL (input)		1	(Active-High) The APB initiator generates this signal to each DRI target. Indicates that the target device is selected and that a data transfer is required. There is a PSELx signal for each target.
PSLVERR (output)		1	(Active-High) This signal indicates a transfer failure.
PWDATA (input)		32	(Active-High) This bus is driven by the APB initiator during write cycles when PWRITE is High.
PWRITE (input)		1	This signal indicates an APB write access when High and an APB read access when Low.

The following sections describe DRI configuration for XCVR, TX PLL, PCIE, and CCC blocks using the **PolarFire Dynamic Reconfiguration Interface Configurator** window.

3.1 DRI Configuration for XCVR [\(Ask a Question\)](#)

In the XCVR tab, individual lanes (LANE_0 – 3) can be selected for each quad lane (Qn Lanes, n = 0 – 5). For example, when Q0_LANE0 and Q0_LANE1 lane check boxes are selected in Q0 Lanes, Q0_LANE0 and Q0_LANE1 ports are added to the DRI IP block. The DRI ports highlighted in the following figure are routed through hardwired connections to the transceiver.

Figure 3-2. The XCVR Tab

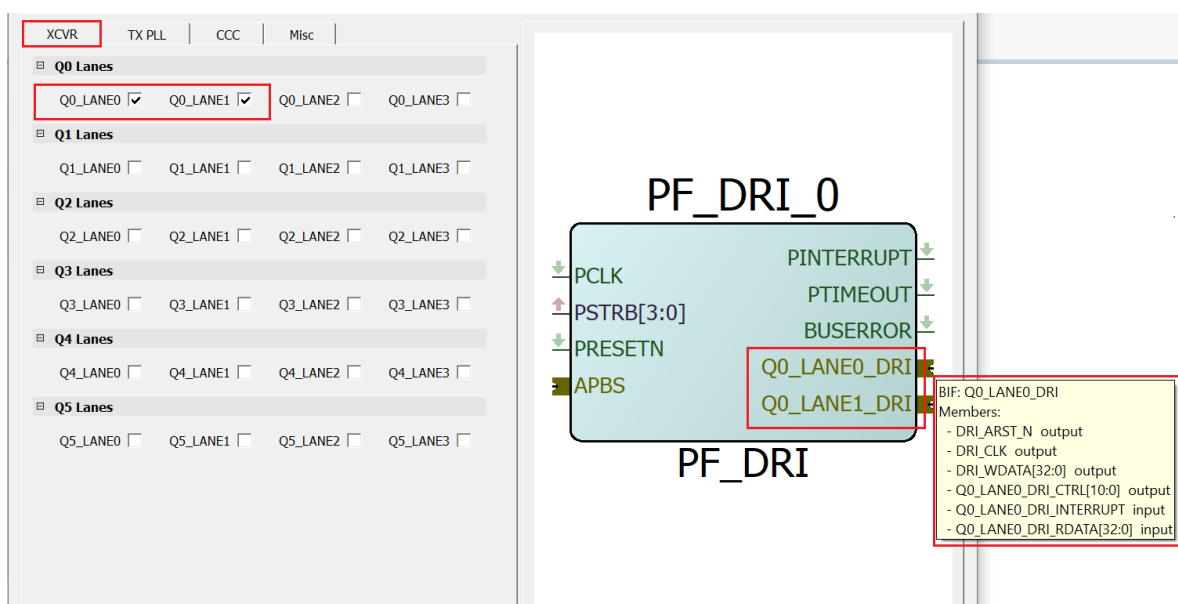

 **Important:** The number of QUADs (Q#) varies based on the device variant.

The following table lists the XCVR DRI ports.

Table 3-2. XCVR DRI Ports

Port Name	Libero® BIF	Direction	Width	Description
DRI_ARST_N	—	Output	1	Active-Low asynchronous Reset signal from DRI to target.
DRI_CLK	—	Output	1	Clock source to the target.
DRI_WDATA	—	Output	32	DRI write data bus driven by DRI during write cycles.
Q#_LANE#_DRI_CTRL	Q#_LANE#_DRI	Output	[10:0]	Embedded connection to specified target peripheral. Q# can be 0, 1, 2, 3, 4, 5, LANE# can be 0, 1, 2, 3.
Q#_LANE#_DRI_INTERRUPT	Q#_LANE#_DRI	Input	—	Embedded connection to specified target peripheral. Q# can be 0, 1, 2, 3, 4, 5, LANE# can be 0, 1, 2, 3.
Q#_LANE#_DRI_RDATA	Q#_LANE#_DRI	Input	[32:0]	Embedded connection to specified target peripheral. Q# can be 0, 1, 2, 3, 4, 5, LANE# can be 0, 1, 2, 3.

For more information about user connections required while using DRI interface, see [AN4592: PolarFire FPGA Dynamic Reconfiguration Interface Application Note \(Earlier AC475\)](#).

3.2 DRI Configuration for TX PLL [\(Ask a Question\)](#)

In the TX PLL tab, the required options per quad to enable DRI for both spread spectrum generation capable transmit PLLs (Q#_TXPLL_SSC) and (Q#_TXPLLn) without spread spectrum capabilities can be selected, see the following figure.

The DRI option is provided for two Q#_TXPLLn (Q#_TXPLL0, Q#_TXPLL1) within transceiver quad locations. The DRI target ports highlighted in the following figure are routed through hardwired connections to the transceiver PLL. For more information, see the “Transmit PLL” section in [PolarFire Family Transceiver User Guide](#).

Figure 3-3. The TX PLL Tab

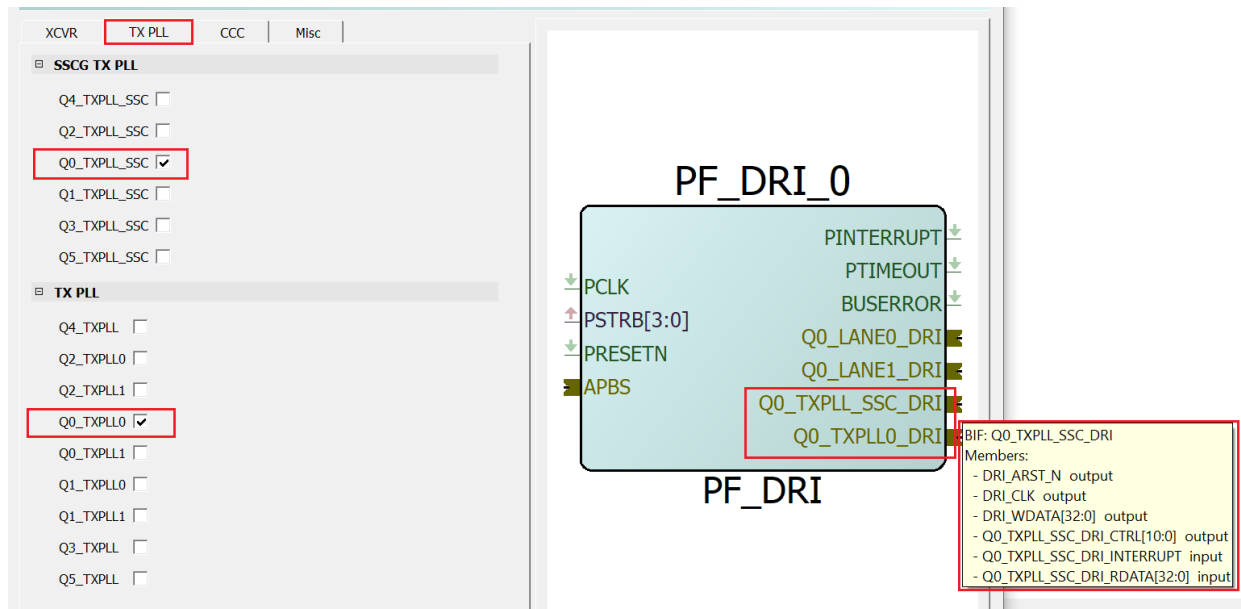

The following table lists the TX PLL DRI ports.

Table 3-3. TX PLL DRI Ports

Port Name	Libero® BIF	Direction	Width	Description
Q#_TXPLL_SSC_DRI_CTRL	Q#_TXPLL_SSC_DRI	Output	[10:0]	Embedded connection to specified target peripheral. Q# can be 0, 1, 2, 3, 4, 5.
Q#_TXPLL_SSC_DRI_RDATA	Q#_TXPLL_SSC_DRI	Input	[32:0]	Embedded connection to specified target peripheral. Q# can be 0, 1, 2, 3, 4, 5.
Q#_TXPLL_SSC_DRI_INTERRUPT	Q#_TXPLL_SSC_DRI	Input	—	Embedded connection to specified target peripheral. Q# can be 0, 1, 2, 3, 4, 5.
Q#_TXPLL_DRI_CTRL	Q#_TXPLL_DRI	Output	[10:0]	Embedded connection to specified target peripheral. Q# can be 3, 4, 5.
Q#_TXPLL_DRI_RDATA	Q#_TXPLL_DRI	Input	[32:0]	Embedded connection to specified target peripheral. Q# can be 3, 4, 5.
Q#_TXPLL_DRI_INTERRUPT	Q#_TXPLL_DRI	Input	—	Embedded connection to specified target peripheral. Q# can be 3, 4, 5.
Q#_TXPLL0_DRI_CTRL	Q#_TXPLL0_DRI	Output	[10:0]	Embedded connection to specified target peripheral. Q# can be 0, 1, 2.
Q#_TXPLL0_DRI_RDATA	Q#_TXPLL0_DRI	Input	[32:0]	Embedded connection to specified target peripheral. Q# can be 0, 1, 2.
Q#_TXPLL0_DRI_INTERRUPT	Q#_TXPLL0_DRI	Input	—	Embedded connection to specified target peripheral. Q# can be 0, 1, 2.
Q#_TXPLL1_DRI_CTRL	Q#_TXPLL1_DRI	Output	[10:0]	Embedded connection to specified target peripheral. Q# can be 0, 1, 2.
Q#_TXPLL1_DRI_RDATA	Q#_TXPLL1_DRI	Input	[32:0]	Embedded connection to specified target peripheral. Q# can be 0, 1, 2.
Q#_TXPLL1_DRI_INTERRUPT	Q#_TXPLL1_DRI	Input	—	Embedded connection to specified target peripheral. Q# can be 0, 1, 2.

3.3 DRI Configuration for PCIE [\(Ask a Question\)](#)

PCIE controllers do not connect directly to a DRI port, the associated XCVR lanes must be connected to the DRI for dynamic control of the XCVR features. The PCIE controllers have a dedicated APB port

for access to the register control within the PCIE subsystem. For more information, see [PolarFire Family PCI Express User Guide](#).

3.4 DRI Configuration for CCC (Ask a Question)

In the CCC tab, the required PLLs and DLLs (in all four corners NW, NE, SE, and SW) can be selected to enable DRI on the selected options and the corresponding DRI target interface is exposed, see the following figure.

Figure 3-4. The CCC Tab

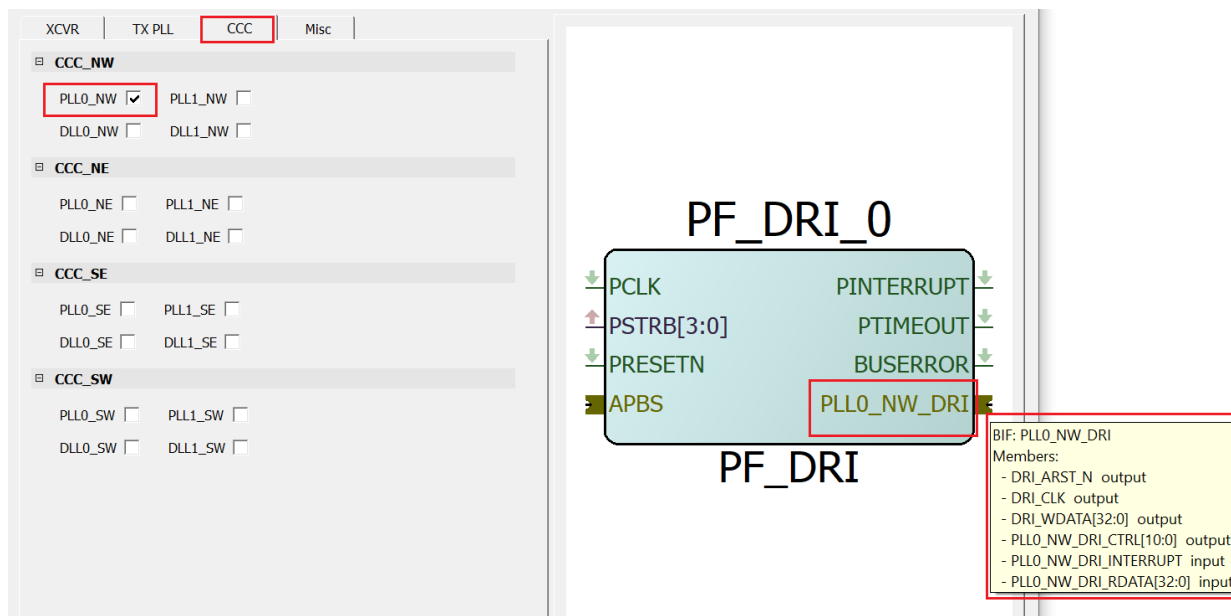

The DRI target ports highlighted in the preceding figure are routed through hardwired connections to the CCC.

The following table lists the CCC DRI ports.

Table 3-4. CCC DRI Ports

Port Name	Libero® BIF	Direction	Width	Description
PLL0_**_DRI_CTRL	PLL0_**_DRI	Output	[10:0]	Embedded connection to specified target peripheral. ** can be NW, NE, SW, or SE.
PLL0_**_DRI_RDATA	PLL0_**_DRI	Input	[32:0]	Embedded connection to specified target peripheral. ** can be NW, NE, SW, or SE.
PLL0_**_DRI_INTERRUPT	PLL0_**_DRI	Input	—	Embedded connection to specified target peripheral. ** can be NW, NE, SW, or SE.
PLL1_**_DRI_CTRL	PLL1_**_DRI	Output	[10:0]	Embedded connection to specified target peripheral. ** can be NW, NE, SW, or SE.
PLL1_**_DRI_RDATA	PLL1_**_DRI	Input	[32:0]	Embedded connection to specified Target peripheral. ** can be NW, NE, SW, or SE.
PLL1_**_DRI_INTERRUPT	PLL1_**_DRI	Input	—	Embedded connection to specified target peripheral. ** can be NW, NE, SW, or SE.
DLL0_**_DRI_CTRL	DLL0_**_DRI	Output	[10:0]	Embedded connection to specified target peripheral. ** can be NW, NE, SW, or SE.
DLL0_**_DRI_RDATA	DLL0_**_DRI	Input	[32:0]	Embedded connection to specified target peripheral. ** can be NW, NE, SW, or SE.
DLL0_**_DRI_INTERRUPT	DLL0_**_DRI	Input	—	Embedded connection to specified target peripheral. ** can be NW, NE, SW, or SE.

.....continued				
Port Name	Libero® BIF	Direction	Width	Description
DLL1_**_DRI_CTRL	DLL1_**_DRI	Output	[10:0]	Embedded connection to specified target peripheral. ** can be NW, NE, SW, or SE.
DLL1_**_DRI_RDATA	DLL1_**_DRI	Input	[32:0]	Embedded connection to specified target peripheral. ** can be NW, NE, SW, or SE.
DLL1_**_DRI_INTERRUPT	DLL1_**_DRI	Input	—	Embedded connection to specified target peripheral. ** can be NW, NE, SW, or SE.

3.4.1 Dynamic Configuration of CCC [\(Ask a Question\)](#)

Each CCC has a DRI which can be enabled to configure CCC parameters without reprogramming the device. The CCC configuration is controlled by the volatile configuration registers that are loaded with values from the Flash configuration bits at power-up. An APB bus initiator must be interfaced to the CCC using a DRI macro for dynamic configuration. The APB bus initiator is used to dynamically modify the CCC configuration register values as per design needs. For more information on CCC configuration registers and their bit definitions, see [PolarFire Device Register Map](#).

To meet all the datasheet specifications, certain requirements must be met when configuring the PLL/DLL parameters. The Libero CCC configurator implements all these requirements and creates a valid solution for the requested output clock frequencies and phases. Hence, Microchip recommends that users generate the required configuration using Libero CCC configurator and use the generated parameters in their dynamic configuration solution.

The PLL_POWERDOWN_N input must be asserted before making changes to the PLL configuration parameters.



Important: Asserting the PLL_POWERDOWN_N signal resets the PLL operation.

When the CCC is configured in internal Post-VCO feedback mode, if the requirement is to change the phase or output divider configuration then the clock start/stop (OUT#_EN) signals can be used to stop the clock output before making the changes for a glitch-free configuration.

The following steps describe how to perform dynamic configuration of CCC:

1. Select **Enable Dynamic Reconfiguration Interface (DRI)** under the **Features** section of CCC configurator, see [Figure 3-5](#). This enables and exposes the DRI on the instantiated CCC component.

Figure 3-5. DRI Option in CCC



2. Instantiate and configure a PF_DRI SgCore with the required PLL enabled into the SmartDesign. The dynamic reconfiguration interface macro converts the APB interface signals to CCC dynamic reconfiguration interface signals. The DRI interface for the selected PLL is exposed on the PF_DRI macro. The APB port of DRI are shown in Figure 3-4. The DRI ports cannot be monitored or altered in the Libero design. These ports are used to facilitate HDL simulation of changes made to the CCC over the DRI. The PF_DRI SgCore converts standard APB3 read/writes to DRI transactions.
3. Double click the DRI macro to configure.
4. Select the PLLs and DLLs that need dynamic configuration from PF_DRI configurator > CCC tab. Figure 3-4 shows the DRI macro interface.
5. Connect the APB initiator port from an APB initiator (for example, CoreABC) to the mirrored initiator port of PF_DRI, see the following figure.

Figure 3-6. CCC Dynamic Configuration System

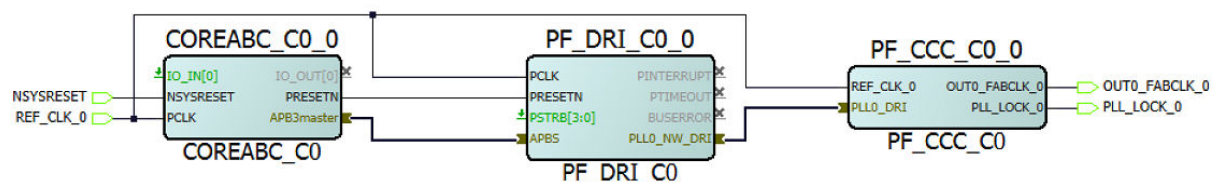

➔ Important: Using DRI, you can modify both PLL0 and PLL1 registers, even when only the PLL0_NW_DRI interface is connected. This is also not limited to just one corner. PLL registers and any SerDes lane register in other corners can also be modified using the same interface.

3.5 Misc Tab [\(Ask a Question\)](#)

In the Misc tab, select the **CRYPTO** option to enable DRI on CRYPTO. For more information, see Figure 3-7.

Note: The **Enable latency simulation** option is currently not supported.

Figure 3-7. Enabling DRI on CRYPTO

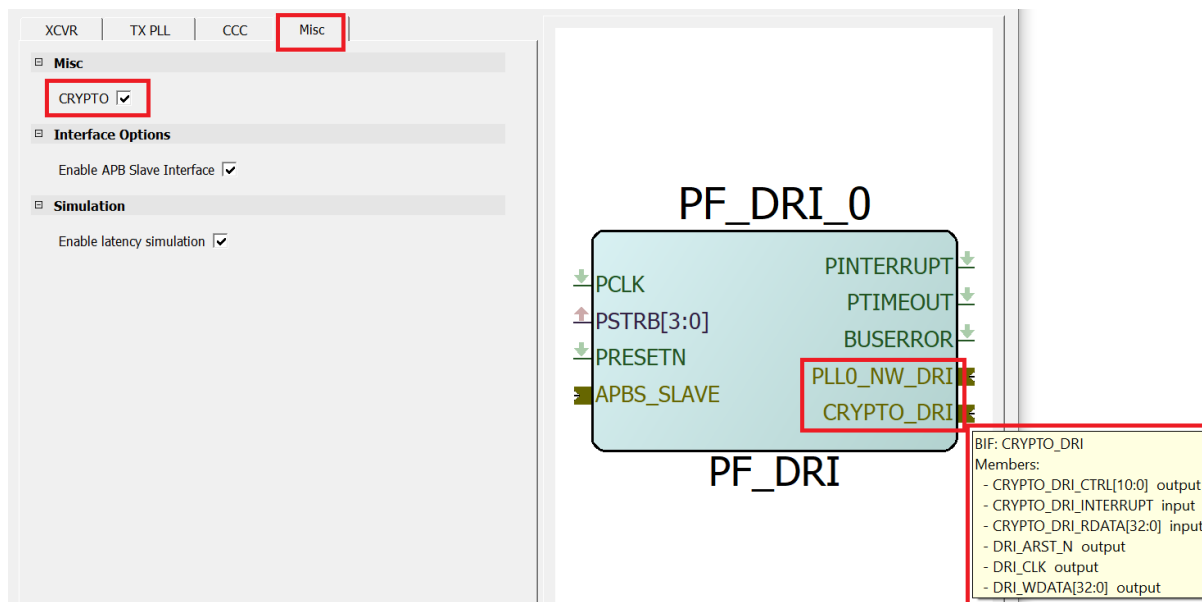

The following table lists the CRYPTO DRI ports.

Table 3-5. CRYPTO DRI Ports

Port Name	Libero® BIF	Direction	Width	Description
CRYPTO_DRI_CTRL	CRYPTO_DRI	Output	[10:0]	Embedded connection to specified target peripheral.
CRYPTO_DRI_RDATA	CRYPTO_DRI	Input	[32:0]	Embedded connection to specified target peripheral.
CRYPTO_DRI_INTERRUPT	CRYPTO_DRI	Input	—	Embedded connection to specified target peripheral.

➔ Important: The ports listed in the preceding table are routed through hardwired connections to the User Crypto Processor.

4. Functional Timing Diagram [\(Ask a Question\)](#)

The following figure shows the DRI timing diagram.

Figure 4-1. APB Initiator Timing Diagram

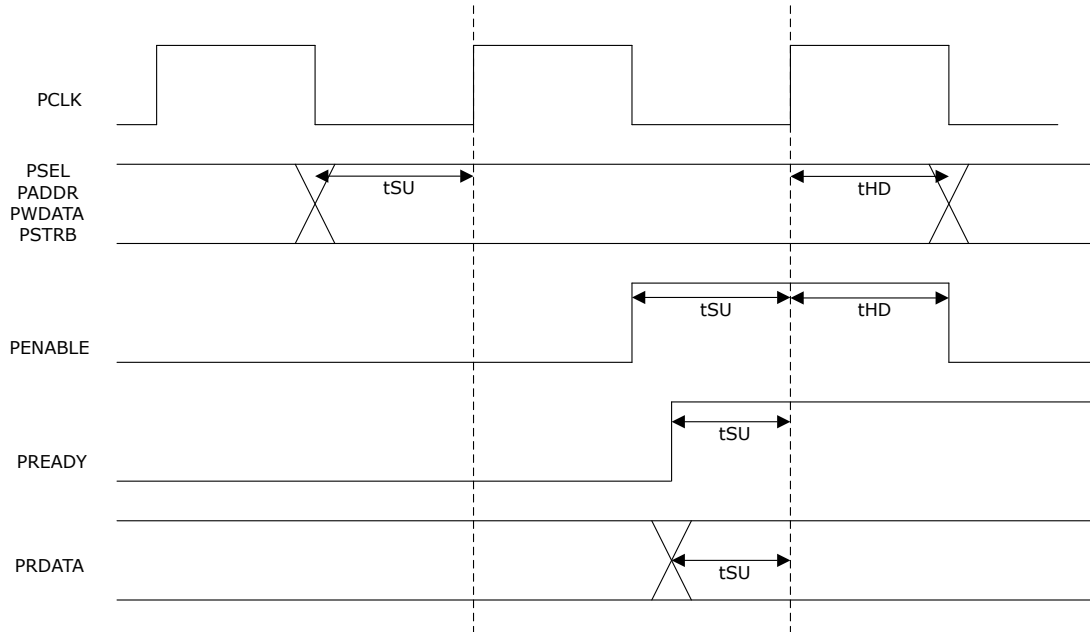

For more information about FPD_PCLK, see [PolarFire FPGA Datasheet](#).

The SDC constraint is derived and generated automatically based on the connection of the PF_DRI IP to its APB initiator and to the DRI peripherals. Static Timing Analysis (STA) of PCLK (FPD_PCLK) with SmartPower gives the minimum and maximum analysis of the APB interface t_{SU}/t_{HD} parameters.

5. Revision History [\(Ask a Question\)](#)

The revision history describes the changes that were implemented in the document. The changes are listed by revision, starting with the most current publication.

Table 5-1. Revision History

Revision	Date	Description
H	10/2024	The following change is made in Revision H of the document: <ul style="list-style-type: none"> Added a note about the requirement to gate <code>DRI_PCLK</code> to PolarFire and RT PolarFire FPGA.
G	01/2024	The following changes are made in Revision G of the document: <ul style="list-style-type: none"> Updated a note to generalize accessing DRI in the following sections: <ul style="list-style-type: none"> PolarFire and RT PolarFire FPGA PolarFire SoC FPGA Added a note about PLL_DRI configuration. See Dynamic Configuration of CCC.
F	06/2023	Added a note in PolarFire and RT PolarFire FPGA mentioning the minimum address space to be allocated for DRI.
E	04/2023	Added RT PolarFire® support.
D	11/2022	Updated the web link to PolarFire SoC bare-metal DRI application in PolarFire SoC FPGA .
C	06/2022	Added a note regarding the number QUADs in DRI Configuration for XCVR .
B	03/2022	<ul style="list-style-type: none"> Updated the PF_DRI Configurator figures throughout the document. Updated links in the document. Added Design Initialization Data Report.
A	06/2021	The first publication of this document.

Microchip FPGA Support

Microchip FPGA products group backs its products with various support services, including Customer Service, Customer Technical Support Center, a website, and worldwide sales offices. Customers are suggested to visit Microchip online resources prior to contacting support as it is very likely that their queries have been already answered.

Contact Technical Support Center through the website at www.microchip.com/support. Mention the FPGA Device Part number, select appropriate case category, and upload design files while creating a technical support case.

Contact Customer Service for non-technical product support, such as product pricing, product upgrades, update information, order status, and authorization.

- From North America, call **800.262.1060**
- From the rest of the world, call **650.318.4460**
- Fax, from anywhere in the world, **650.318.8044**

Microchip Information

The Microchip Website

Microchip provides online support via our website at www.microchip.com/. This website is used to make files and information easily available to customers. Some of the content available includes:

- **Product Support** – Data sheets and errata, application notes and sample programs, design resources, user's guides and hardware support documents, latest software releases and archived software
- **General Technical Support** – Frequently Asked Questions (FAQs), technical support requests, online discussion groups, Microchip design partner program member listing
- **Business of Microchip** – Product selector and ordering guides, latest Microchip press releases, listing of seminars and events, listings of Microchip sales offices, distributors and factory representatives

Product Change Notification Service

Microchip's product change notification service helps keep customers current on Microchip products. Subscribers will receive email notification whenever there are changes, updates, revisions or errata related to a specified product family or development tool of interest.

To register, go to www.microchip.com/pcn and follow the registration instructions.

Customer Support

Users of Microchip products can receive assistance through several channels:

- Distributor or Representative
- Local Sales Office
- Embedded Solutions Engineer (ESE)
- Technical Support

Customers should contact their distributor, representative or ESE for support. Local sales offices are also available to help customers. A listing of sales offices and locations is included in this document.

Technical support is available through the website at: www.microchip.com/support

Microchip Devices Code Protection Feature

Note the following details of the code protection feature on Microchip products:

- Microchip products meet the specifications contained in their particular Microchip Data Sheet.
- Microchip believes that its family of products is secure when used in the intended manner, within operating specifications, and under normal conditions.
- Microchip values and aggressively protects its intellectual property rights. Attempts to breach the code protection features of Microchip product is strictly prohibited and may violate the Digital Millennium Copyright Act.
- Neither Microchip nor any other semiconductor manufacturer can guarantee the security of its code. Code protection does not mean that we are guaranteeing the product is “unbreakable”. Code protection is constantly evolving. Microchip is committed to continuously improving the code protection features of our products.

Legal Notice

This publication and the information herein may be used only with Microchip products, including to design, test, and integrate Microchip products with your application. Use of this information in any other manner violates these terms. Information regarding device applications is provided only for your convenience and may be superseded by updates. It is your responsibility to ensure that your application meets with your specifications. Contact your local Microchip sales office for additional support or, obtain additional support at www.microchip.com/en-us/support/design-help/client-support-services.

THIS INFORMATION IS PROVIDED BY MICROCHIP “AS IS”. MICROCHIP MAKES NO REPRESENTATIONS OR WARRANTIES OF ANY KIND WHETHER EXPRESS OR IMPLIED, WRITTEN OR ORAL, STATUTORY OR OTHERWISE, RELATED TO THE INFORMATION INCLUDING BUT NOT LIMITED TO ANY IMPLIED WARRANTIES OF NON-INFRINGEMENT, MERCHANTABILITY, AND FITNESS FOR A PARTICULAR PURPOSE, OR WARRANTIES RELATED TO ITS CONDITION, QUALITY, OR PERFORMANCE.

IN NO EVENT WILL MICROCHIP BE LIABLE FOR ANY INDIRECT, SPECIAL, PUNITIVE, INCIDENTAL, OR CONSEQUENTIAL LOSS, DAMAGE, COST, OR EXPENSE OF ANY KIND WHATSOEVER RELATED TO THE INFORMATION OR ITS USE, HOWEVER CAUSED, EVEN IF MICROCHIP HAS BEEN ADVISED OF THE POSSIBILITY OR THE DAMAGES ARE FORESEEABLE. TO THE FULLEST EXTENT ALLOWED BY LAW, MICROCHIP’S TOTAL LIABILITY ON ALL CLAIMS IN ANY WAY RELATED TO THE INFORMATION OR ITS USE WILL NOT EXCEED THE AMOUNT OF FEES, IF ANY, THAT YOU HAVE PAID DIRECTLY TO MICROCHIP FOR THE INFORMATION.

Use of Microchip devices in life support and/or safety applications is entirely at the buyer’s risk, and the buyer agrees to defend, indemnify and hold harmless Microchip from any and all damages, claims, suits, or expenses resulting from such use. No licenses are conveyed, implicitly or otherwise, under any Microchip intellectual property rights unless otherwise stated.

Trademarks

The Microchip name and logo, the Microchip logo, Adaptec, AVR, AVR logo, AVR Freaks, BesTime, BitCloud, CryptoMemory, CryptoRF, dsPIC, flexPWR, HELDO, IGLOO, JukeBlox, KeeLoq, Kleer, LANCheck, LinkMD, maXStylus, maXTouch, MediaLB, megaAVR, Microsemi, Microsemi logo, MOST, MOST logo, MPLAB, OptoLyzer, PIC, picoPower, PICSTART, PIC32 logo, PolarFire, Prochip Designer, QTouch, SAM-BA, SenGenuity, SpyNIC, SST, SST Logo, SuperFlash, Symmetricom, SyncServer, Tachyon, TimeSource, tinyAVR, UNI/O, Vectron, and XMEGA are registered trademarks of Microchip Technology Incorporated in the U.S.A. and other countries.

AgileSwitch, ClockWorks, The Embedded Control Solutions Company, EtherSynch, Flashtec, Hyper Speed Control, HyperLight Load, Libero, motorBench, mTouch, Powermite 3, Precision Edge, ProASIC, ProASIC Plus, ProASIC Plus logo, Quiet-Wire, SmartFusion, SyncWorld, TimeCesium, TimeHub, TimePictra, TimeProvider, and ZL are registered trademarks of Microchip Technology Incorporated in the U.S.A.

Adjacent Key Suppression, AKS, Analog-for-the-Digital Age, Any Capacitor, AnyIn, AnyOut, Augmented Switching, BlueSky, BodyCom, Clockstudio, CodeGuard, CryptoAuthentication, CryptoAutomotive, CryptoCompanion, CryptoController, dsPICDEM, dsPICDEM.net, Dynamic

Average Matching, DAM, ECAN, Espresso T1S, EtherGREEN, EyeOpen, GridTime, IdealBridge, IGaT, In-Circuit Serial Programming, ICSP, INICnet, Intelligent Paralleling, IntelliMOS, Inter-Chip Connectivity, JitterBlocker, Knob-on-Display, MarginLink, maxCrypto, maxView, memBrain, Minda, MiWi, MPASM, MPF, MPLAB Certified logo, MPLIB, MPLINK, mSiC, MultiTRAK, NetDetach, Omniscient Code Generation, PICDEM, PICDEM.net, PICkit, PICtail, Power MOS IV, Power MOS 7, PowerSmart, PureSilicon, QMatrix, REAL ICE, Ripple Blocker, RTAX, RTG4, SAM-ICE, Serial Quad I/O, simpleMAP, SimpliPHY, SmartBuffer, SmartHLS, SMART-I.S., storClad, SQL, SuperSwitcher, SuperSwitcher II, Switchtec, SynchroPHY, Total Endurance, Trusted Time, TSHARC, Turing, USBCheck, VariSense, VectorBlox, VeriPHY, ViewSpan, WiperLock, XpressConnect, and ZENA are trademarks of Microchip Technology Incorporated in the U.S.A. and other countries.

SQTP is a service mark of Microchip Technology Incorporated in the U.S.A.

The Adaptec logo, Frequency on Demand, Silicon Storage Technology, and Symmcom are registered trademarks of Microchip Technology Inc. in other countries.

GestIC is a registered trademark of Microchip Technology Germany II GmbH & Co. KG, a subsidiary of Microchip Technology Inc., in other countries.

All other trademarks mentioned herein are property of their respective companies.

© 2024, Microchip Technology Incorporated and its subsidiaries. All Rights Reserved.

ISBN: 978-1-6683-0368-9

Quality Management System

For information regarding Microchip's Quality Management Systems, please visit www.microchip.com/quality.

Worldwide Sales and Service

AMERICAS	ASIA/PACIFIC	ASIA/PACIFIC	EUROPE
<p>Corporate Office 2355 West Chandler Blvd. Chandler, AZ 85224-6199 Tel: 480-792-7200 Fax: 480-792-7277 Technical Support: www.microchip.com/support Web Address: www.microchip.com</p> <p>Atlanta Duluth, GA Tel: 678-957-9614 Fax: 678-957-1455</p> <p>Austin, TX Tel: 512-257-3370</p> <p>Boston Westborough, MA Tel: 774-760-0087 Fax: 774-760-0088</p> <p>Chicago Itasca, IL Tel: 630-285-0071 Fax: 630-285-0075</p> <p>Dallas Addison, TX Tel: 972-818-7423 Fax: 972-818-2924</p> <p>Detroit Novi, MI Tel: 248-848-4000</p> <p>Houston, TX Tel: 281-894-5983</p> <p>Indianapolis Noblesville, IN Tel: 317-773-8323 Fax: 317-773-5453 Tel: 317-536-2380</p> <p>Los Angeles Mission Viejo, CA Tel: 949-462-9523 Fax: 949-462-9608 Tel: 951-273-7800</p> <p>Raleigh, NC Tel: 919-844-7510</p> <p>New York, NY Tel: 631-435-6000</p> <p>San Jose, CA Tel: 408-735-9110 Tel: 408-436-4270</p> <p>Canada - Toronto Tel: 905-695-1980 Fax: 905-695-2078</p>	<p>Australia - Sydney Tel: 61-2-9868-6733</p> <p>China - Beijing Tel: 86-10-8569-7000</p> <p>China - Chengdu Tel: 86-28-8665-5511</p> <p>China - Chongqing Tel: 86-23-8980-9588</p> <p>China - Dongguan Tel: 86-769-8702-9880</p> <p>China - Guangzhou Tel: 86-20-8755-8029</p> <p>China - Hangzhou Tel: 86-571-8792-8115</p> <p>China - Hong Kong SAR Tel: 852-2943-5100</p> <p>China - Nanjing Tel: 86-25-8473-2460</p> <p>China - Qingdao Tel: 86-532-8502-7355</p> <p>China - Shanghai Tel: 86-21-3326-8000</p> <p>China - Shenyang Tel: 86-24-2334-2829</p> <p>China - Shenzhen Tel: 86-755-8864-2200</p> <p>China - Suzhou Tel: 86-186-6233-1526</p> <p>China - Wuhan Tel: 86-27-5980-5300</p> <p>China - Xian Tel: 86-29-8833-7252</p> <p>China - Xiamen Tel: 86-592-2388138</p> <p>China - Zhuhai Tel: 86-756-3210040</p>	<p>India - Bangalore Tel: 91-80-3090-4444</p> <p>India - New Delhi Tel: 91-11-4160-8631</p> <p>India - Pune Tel: 91-20-4121-0141</p> <p>Japan - Osaka Tel: 81-6-6152-7160</p> <p>Japan - Tokyo Tel: 81-3-6880-3770</p> <p>Korea - Daegu Tel: 82-53-744-4301</p> <p>Korea - Seoul Tel: 82-2-554-7200</p> <p>Malaysia - Kuala Lumpur Tel: 60-3-7651-7906</p> <p>Malaysia - Penang Tel: 60-4-227-8870</p> <p>Philippines - Manila Tel: 63-2-634-9065</p> <p>Singapore Tel: 65-6334-8870</p> <p>Taiwan - Hsin Chu Tel: 886-3-577-8366</p> <p>Taiwan - Kaohsiung Tel: 886-7-213-7830</p> <p>Taiwan - Taipei Tel: 886-2-2508-8600</p> <p>Thailand - Bangkok Tel: 66-2-694-1351</p> <p>Vietnam - Ho Chi Minh Tel: 84-28-5448-2100</p>	<p>Austria - Wels Tel: 43-7242-2244-39 Fax: 43-7242-2244-393</p> <p>Denmark - Copenhagen Tel: 45-4485-5910 Fax: 45-4485-2829</p> <p>Finland - Espoo Tel: 358-9-4520-820</p> <p>France - Paris Tel: 33-1-69-53-63-20 Fax: 33-1-69-30-90-79</p> <p>Germany - Garching Tel: 49-8931-9700</p> <p>Germany - Haan Tel: 49-2129-3766400</p> <p>Germany - Heilbronn Tel: 49-7131-72400</p> <p>Germany - Karlsruhe Tel: 49-721-625370</p> <p>Germany - Munich Tel: 49-89-627-144-0 Fax: 49-89-627-144-44</p> <p>Germany - Rosenheim Tel: 49-8031-354-560</p> <p>Israel - Hod Hasharon Tel: 972-9-775-5100</p> <p>Italy - Milan Tel: 39-0331-742611 Fax: 39-0331-466781</p> <p>Italy - Padova Tel: 39-049-7625286</p> <p>Netherlands - Drunen Tel: 31-416-690399 Fax: 31-416-690340</p> <p>Norway - Trondheim Tel: 47-72884388</p> <p>Poland - Warsaw Tel: 48-22-3325737</p> <p>Romania - Bucharest Tel: 40-21-407-87-50</p> <p>Spain - Madrid Tel: 34-91-708-08-90 Fax: 34-91-708-08-91</p> <p>Sweden - Gothenberg Tel: 46-31-704-60-40</p> <p>Sweden - Stockholm Tel: 46-8-5090-4654</p> <p>UK - Wokingham Tel: 44-118-921-5800 Fax: 44-118-921-5820</p>