Hardware Design Checklist

1.0 INTRODUCTION

This document provides a hardware design checklist for the Microchip USB3341. These checklist items should be followed when utilizing the USB3341 in a new design. A summary of these items is provided in [Section 9.0, "Hardware Checklist Summary," on page 9](#). Detailed information on these subjects can be found in the corresponding sections:

- [Section 2.0, "General Considerations"](#)
- [Section 3.0, "Power"](#)
- [Section 4.0, "USB"](#)
- [Section 5.0, "Clock Circuit"](#)
- [Section 7.0, "Startup"](#)
- [Section 8.0, "Miscellaneous"](#)

2.0 GENERAL CONSIDERATIONS

2.1 Required References

The USB3341 implementor should have the following documents on hand:

- *USB3341 Data Sheet*
- *AN19.17 ULPI Design Guide*
- *AN18.15 PCB Design Guidelines for QFN and DQFN Packages*
- *AN26.21 USB Device Design Checklist*
- USB 2.0 Specification
- ULPI Specification

2.2 Pin Check

Check the pinout of the part against the data sheet. Ensure that all pins match the data sheet and are configured as inputs, outputs, or bidirectional for error checking.

2.3 Ground

- The ground flag, **GND**, must be connected to the solid ground plane on the board.
- The ground flag is the only circuit ground for power. Other signals that are connected to ground should not be relied upon to provide ground.
- **GND** is also the main path for removing heat from the USB3341. It is therefore important that there are enough vias under the USB3341 connecting it to the ground and that those vias are evenly distributed.
- It is also important that the vias be plugged or vented in such a way as to prevent voids from forming in the solder connection. For details on this topic, see the *AN18.15* and *AN26.21* application notes.

3.0 POWER

- USB3341 requires power at:
 - 3.3V for USB analog circuits on **VDD33** pins
 - 1.8V for internal digital circuits on **VDD18** pins

USB3341

- USB3341 contains internal voltage regulators at 3.3V and 1.8V. The 3.3V regulator is enabled automatically when **VBAT** is supplied. Otherwise, 3.3V must be supplied externally, and the 3.3V regulator is automatically disabled.
 - **VDD18** (pin 22 /B3) must have a 1.0 μF filter capacitor attached and connected to ground. One capacitor for both pins is sufficient.
 - **VDD33** (pin15) must have a 1.0 μF filter capacitor attached if the 3.3V regulator is enabled, having less than 1Ω ESR, connected to ground. If the 3.3V regulator is disabled, it should have a 1.0 μF decoupling capacitor attached and connected to ground.
 - **VDD18** and **VDA33** may not be used to supply power to other devices.
- **VBAT** (pin 16) may be supplied from **VBUS**. In this case, an overvoltage protection should be added to the **VBAT** input for protection from surges on **VBUS**. In addition, R_{VBUS} must be added to the **VBUS** input.

The power and ground connections are shown in [Figure 3-1](#), [Figure 3-2](#), and [Figure 3-3](#).

FIGURE 3-1: POWER AND GROUND CONNECTIONS, INTERNAL REGULATION

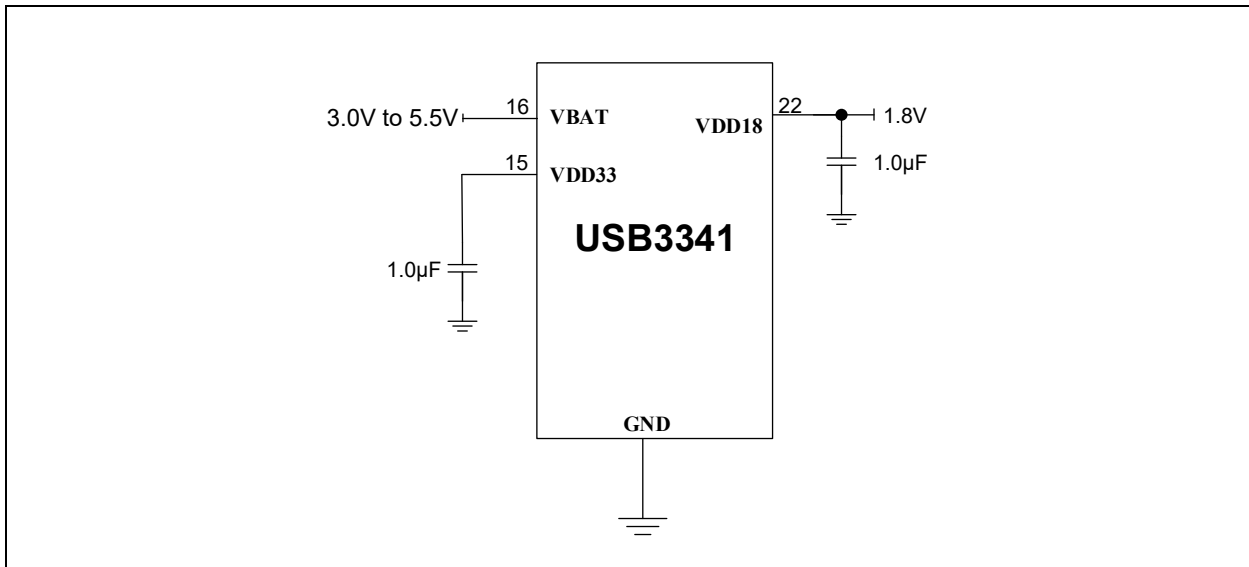

FIGURE 3-2: POWER AND GROUND CONNECTIONS, EXTERNAL REGULATION

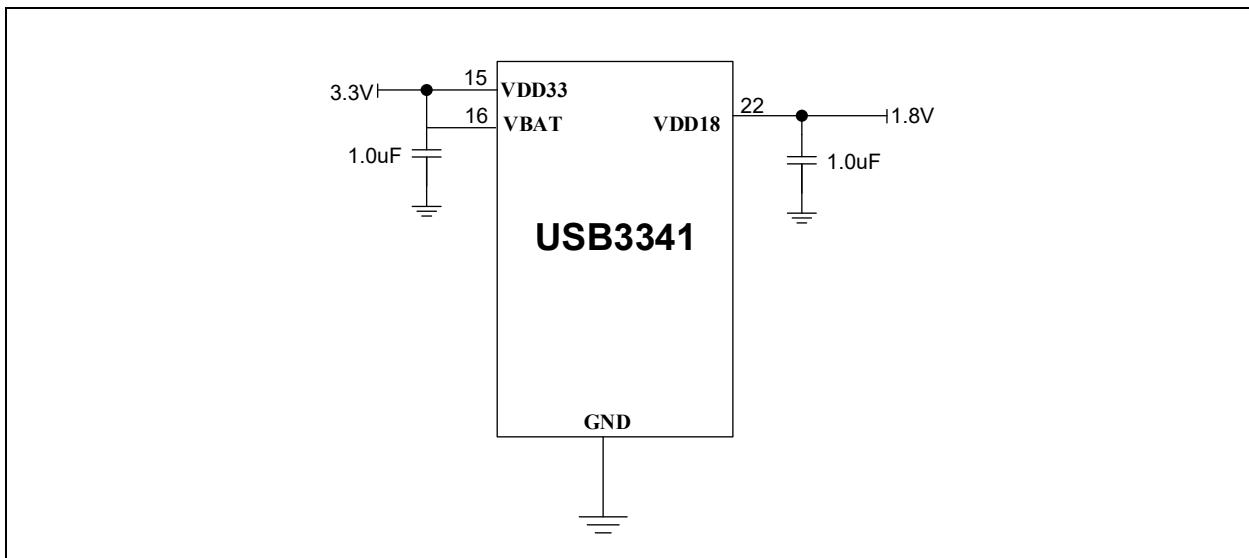
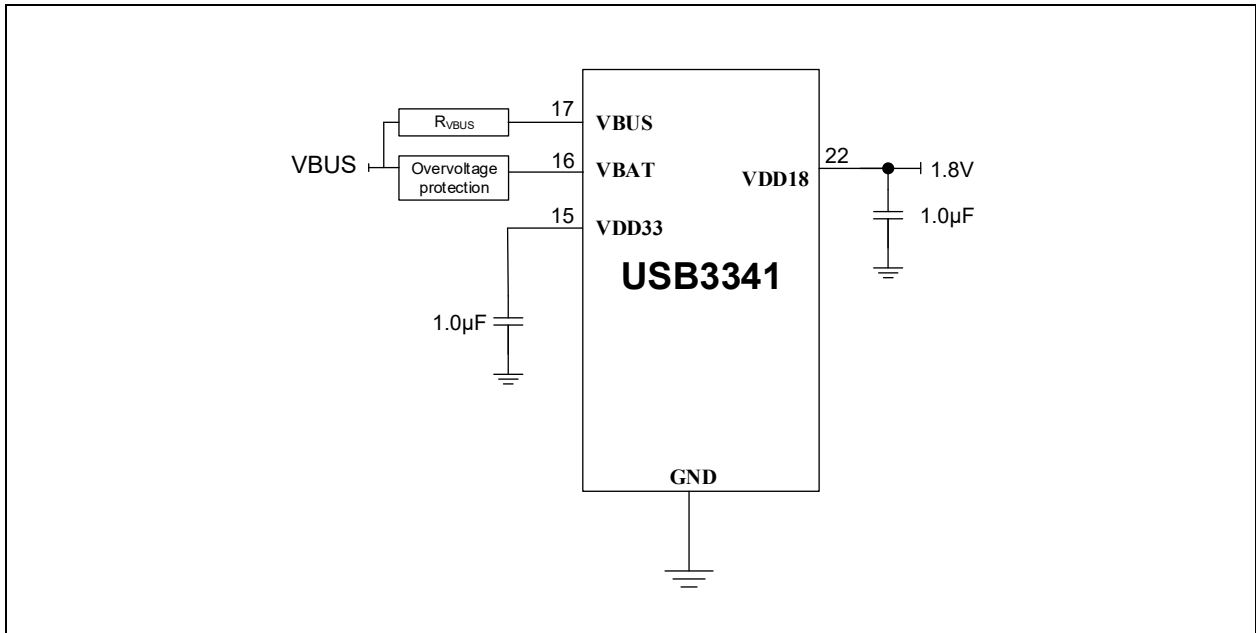

FIGURE 3-3: POWER AND GROUND CONNECTIONS, VBUS-SUPPLIED



USB3341

4.0 USB

USB operation is defined by the USB 2.0 Specification. This specification may be obtained from USB Implementers Forum (USB-IF) at www.usb.org. USB3341 implementors should have a copy of the USB 2.0 Specification and should be familiar with its contents.

The USB3341 can be used for the PHY level of a USB peripheral (device) or a USB host, or a USB On-The-Go (OTG) device (capable as either host or peripheral). (See [Figure 4-1](#) and [Figure 4-2](#).) The required behaviors of each are defined in the USB 2.0 Specification.

4.1 USB Signals

- **DP** (pin 13): This is the positive signal of the USB signal pair.
- **DM** (pin 14): This is the negative signal of the USB signal pair.
 - **DP** and **DM** signals should have controlled impedance. Control the single-ended characteristic impedance (Z_0) of USB signals to between 40Ω and 55Ω . Control the differential impedance (Z_{diff}) of the DP/DM signals to 90Ω , $+5/-10\Omega$.
- **VBUS** (pin 17): This is the VBUS signal. The USB3341 uses this pin for the VBUS comparator inputs and for VBUS pulsing during session request protocol.
 - R_{VBUS} may be installed in this configuration to assist in protecting the **VBUS** pin. An R_{VBUS} of 820Ω will protect against VBUS transients up to 8.5V. An R_{VBUS} of $10\text{ k}\Omega$ will protect against transients up to 10V.
 - C_{VBUS} is a transient-suppressing capacitor that is required for USB 2.0 compliance. For a USB 2.0 host, the recommended value for C_{VBUS} is $120\ \mu\text{F}$. For a USB 2.0 device, the recommended value for C_{VBUS} is $1\ \mu\text{F}$. C_{VBUS} should be located near the USB receptacle and nearer to the receptacle than R_{VBUS} .
- **ID** (pin 18): This is the ID input used for USB On-The-Go (OTG) applications. In OTG applications, the ID pin is connected to the ID pin of the OTG-compatible USB Connector and is used to determine the type of USB cable that is connected.
 - When connected to a non-OTG device or an OTG B-Device, this pin floats and is pulled up by an internal resistor.
 - When connected to an OTG A-Device, the ID pin is pulled to the ground by the device.

FIGURE 4-1: USB CONNECTIONS IN A PERIPHERAL APPLICATION

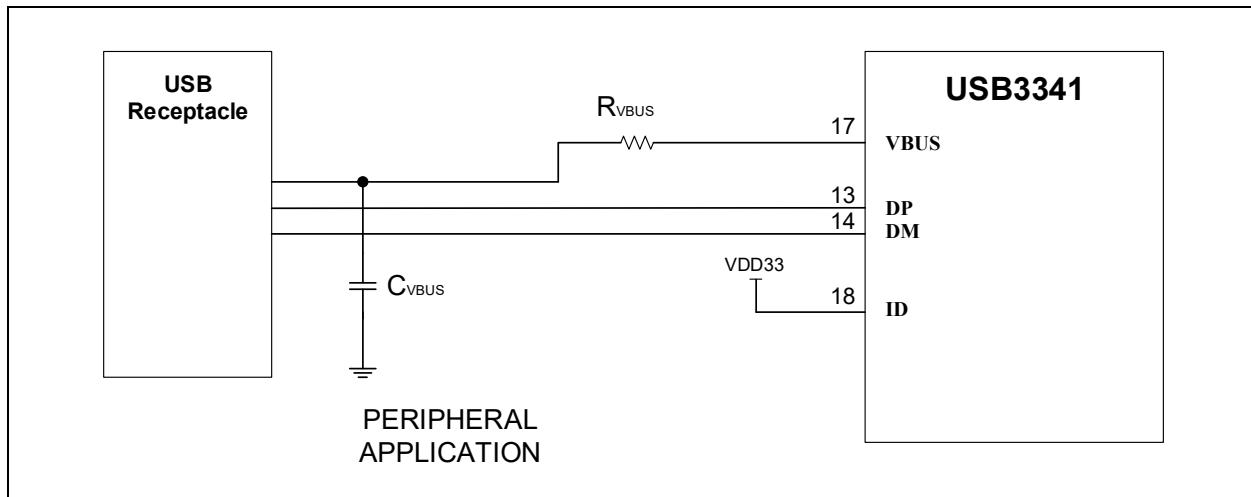
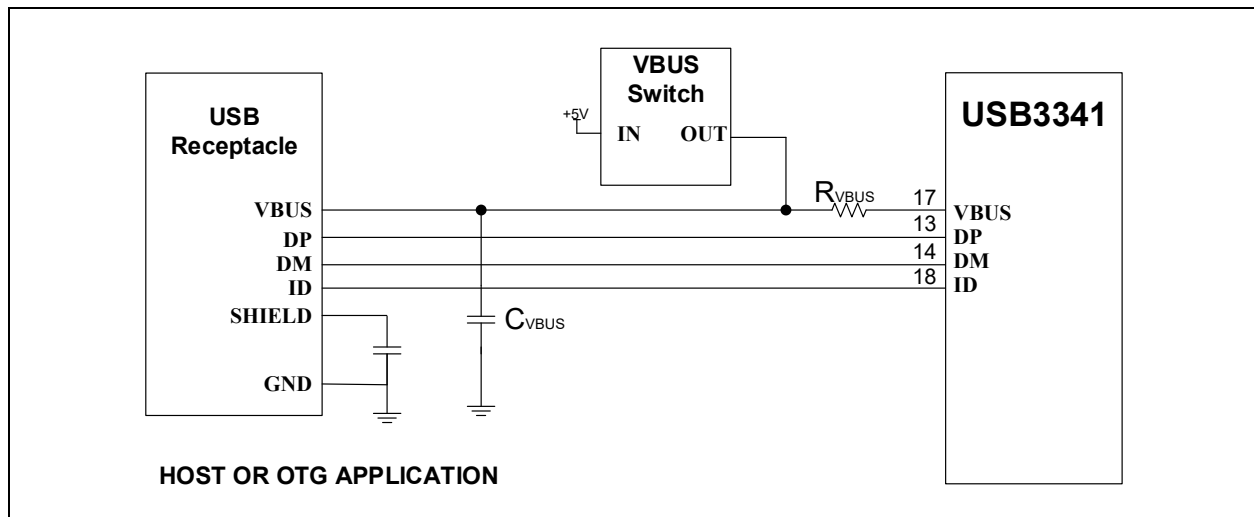

FIGURE 4-2: USB CONNECTIONS IN A HOST OR OTG APPLICATION



4.2 VBUS Switch

The USB 2.0 host or OTG applications must be able to provide 5V on **VBUS** to supply power to USB devices that are attached. The current requirement varies considerably. The USB 2.0 Specification should be consulted for a complete explanation of the VBUS power requirements:

- 100 mA is required for all devices at connection and for low-power, bus-powered devices.
- 500 mA is required for high-power, bus-powered devices.
- As much as 5A total may be required for battery charging and other device circuits.

USB3341 supports these requirements by means of an external 5V switch. The VBUS switch connects a 5V supply to **VBUS** under ULPI register instruction and can detect the current that is supplied through **VBUS**.

The VBUS switch should feature current detection. To be compliant with the USB 2.0 Specification, the current limit must be no more than 5A.

Factors to consider in selecting a VBUS switch include:

- The current rating of the switch, the current at which the switch asserts the FAULT signal, and the amount of current the system is required to provide
- The capability of the switch to provide protection from reverse currents in the On and Off states

The *USB3341 Data Sheet* contains additional detail regarding the operation of an external VBUS switch by the USB3341.

4.3 ESD and EMI

The use of external components (diodes, capacitors, and inductors) applied to USB signals is not generally recommended unless there is a specific need for such protection. Such components tend to make USB-IF compliance tests more difficult to pass, which can add time and cost to a project. At the same time, USB3341 is tolerant of protection devices that have been designed specifically for USB 2.0 signal application, and which are guaranteed compliant by their manufacturers.

USB3341

5.0 CLOCK CIRCUIT

5.1 ULPI Clock Modes

The USB3341 is designed to operate in one of two available modes: ULPI Input Clock and ULPI Output Clock.

In the ULPI Input Clock mode, a 60 MHz ULPI clock is driven to the REFCLK pin 20. In the ULPI Output Clock mode, the USB3341 generates the ULPI clock to the CLKOUT pin 1. The frequency of the ULPI clock is always 60 MHz. See [Figure 5-1](#).

FIGURE 5-1: ULPI CLOCK MODES

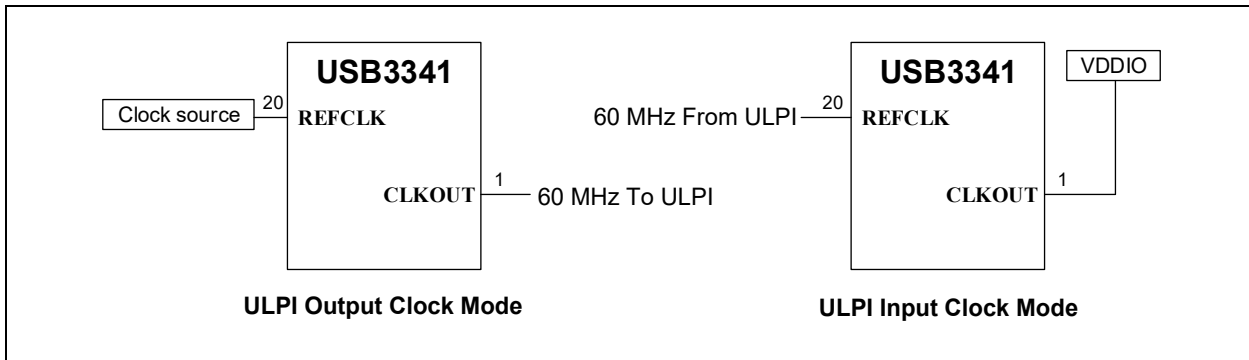

5.2 Reference Frequency

The USB3341 can receive an external reference frequency. In addition, the USB3341 has the ability to either receive or provide the ULPI clock. When the USB3341 is in the ULPI Input Clock mode, the ULPI clock is applied to REFCLK and the frequency is always 60 MHz.

See [Figure 5-2](#).

FIGURE 5-2: OSCILLATOR AND CLOCK CONNECTIONS

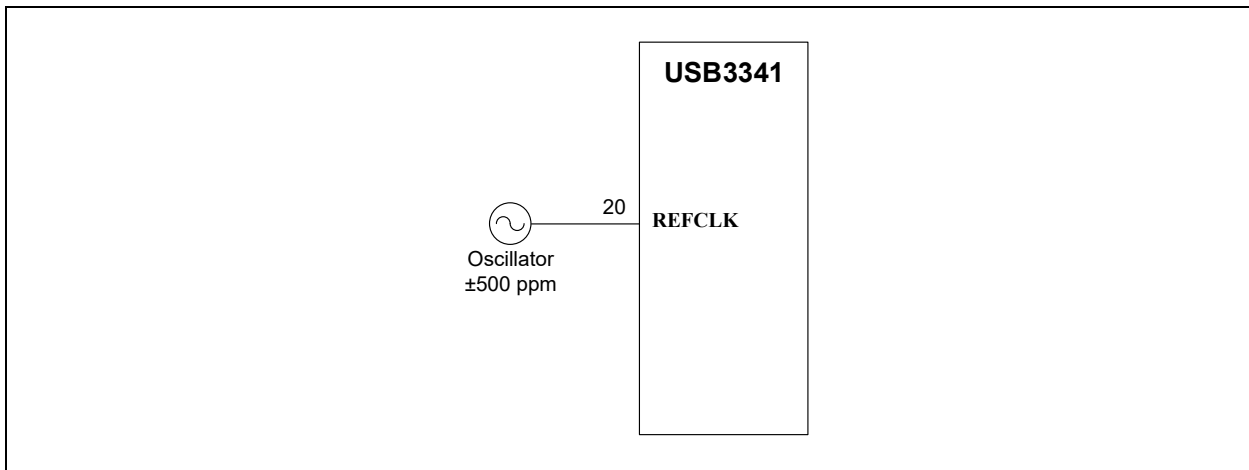

6.0 ULPI INTERFACE

- The ULPI interface connects the PHY layer (USB3341) to the LINK layer. The LINK layer consists of an ASIC, FPGA, or other SOC combined with the LINK layer firmware. The ULPI interface is a single-ended, bidirectional bus that operates at 60 MHz. Refer to [Table 6-1](#) and [Figure 6-1](#).

TABLE 6-1: ULPI SIGNALS

ULPI Signal	Description
DATA[7:0]	Bidirectional data signals
STP	Input from the link layer
DIR	Output to the link layer
NXT	Output to the link layer

- The ULPI interface is intended to cover short distances between integrated circuits on the same PCB. It is not expected to operate through connectors or a cable.
- ULPI DATA traces should be of similar length although precisely equal lengths are not required.
- ULPI traces should not have stubs or components to V_{CC} or ground (such as capacitors).
- ULPI operation is covered in the *USB3341 Data Sheet* and in the *AN19.17 Application Note*.

FIGURE 6-1: ULPI CONNECTIONS

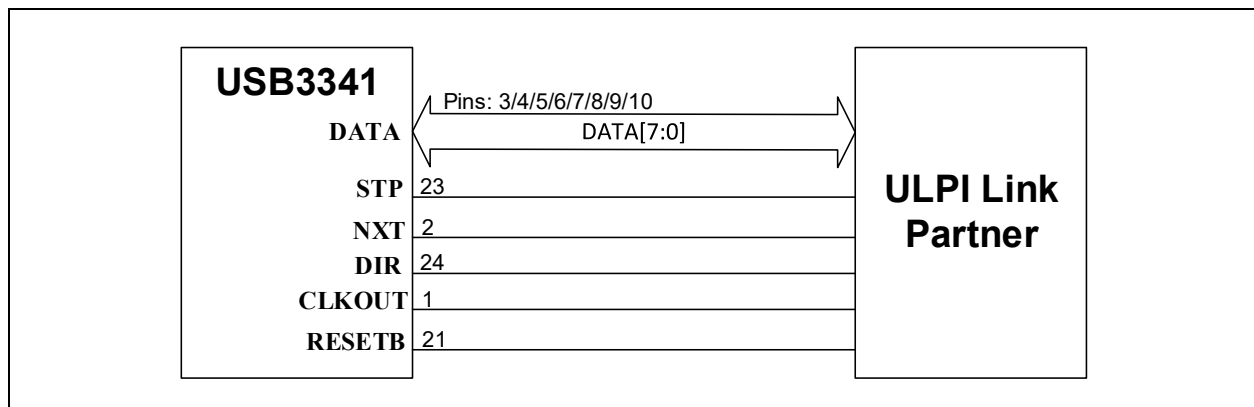

USB3341

7.0 STARTUP

7.1 Reset Circuit

The **RESETB** (pin 22) is an active-low transceiver Reset. The use of the **RESETB** pin is optional. The state of this pin may be changed asynchronously to the clock signals. When asserted for a minimum of 1 ms and then deasserted, the ULPI registers are reset to their default state and all internal state machines are reset.

The LINK must drive the **RESETB** pin to the desired state at all times (including system start-up), or connect the **RESETB** pin to **VDDIO**.

8.0 MISCELLANEOUS

8.1 RBIAS Resistor

The **RBIAS** (pin 19) on the USB3341 must connect to the ground through a 6.06 kΩ resistor with a tolerance of $\pm 1.0\%$. This is essential to the correct setup of critical bias currents.

8.2 Connector Selection

The normal connector type selection is based on the role of the USB3341.

- For a host, a Type-A receptacle is used.
- For a device, a Type-B, Mini-B, or Micro-B receptacle is used.
- For a system that implements a Type-C port, either Host or Device mode may be implemented. The system integrator must ensure that the Type-C port role and the mode of operation of the PHY are also in alignment.

For USB 2.0 Specification compliance, the designer should select a USB receptacle to which the USB Integrators Forum has assigned a Test Certification ID (TID). TID numbers that exist for connectors are listed at <https://usb.org/products>.

9.0 HARDWARE CHECKLIST SUMMARY

TABLE 9-1: HARDWARE DESIGN CHECKLIST

Section	Check	Explanation	√	Notes
Section 2.0, "General Considerations"	Section 2.1, "Required References"	All necessary documents are on hand.		
	Section 2.2, "Pin Check"	The pins match the data sheet.		
Section 3.0, "Power"		Each VDD33 pin is supplied between 3.0V and 3.6V.		
		For internal VDD33 regulation, 1.0 μ F is present on VDD33 .		
		For external VDD33 regulation, 1.0 μ F is present on VDD33 .		
		A capacitor of 1.0 μ F is present on the VDD18 .		
		VDD18 is not connected to other devices.		
Section 4.0, "USB"	Section 4.0, "USB"	A copy of the USB 2.0 Specification has been downloaded from www.usb.org .		
	Section 4.1, "USB Signals"	DP and DM are routed with differential impedance of 90 Ω .		
		DP and DM are routed with single-ended impedance of 40 Ω to 55 Ω .		
		VBUS is connected to CVBUS of 120 μ F if host, otherwise 1 μ F. CVBUS is located near the USB receptacle.		
		VBUS is connected with optional RVBUS no greater than 10 k Ω .		
		For host, ID pin is connected to the receptacle.		
	Section 4.2, "VBUS Switch"	A VBUS switch has been selected according to system requirements.		

TABLE 9-1: HARDWARE DESIGN CHECKLIST (CONTINUED)

Section	Check	Explanation	√	Notes
Section 5.0, "Clock Circuit"	Section 5.1, "ULPI Clock Modes" and Section 5.2, "Reference Frequency"	For the internal oscillator, the crystal is rated 500 μ W or greater.		
		For internal oscillator, the loading capacitors match the crystal manufacturer's specification.		
		For the internal oscillator, the crystal or capacitor traces are short.		
		If crystal is used, it should be rated for a drive level of at least 500 μ W at \pm 500 ppm.		
		For the external oscillator, the signal amplitude is 0V to 3.3V (nominal).		
Section 6.0, "ULPI Interface"		ULPI DATA signals are of similar length to the extent practical.		
		ULPI DATA signals have no stubbing (parallel) components connected.		
		No ULPI signal is connected to a header or external connection.		
		ULPI DATA signals do not traverse stubbing vias.		
Section 7.0, "Startup"	Section 7.1, "Reset Circuit"	If RESET is to be driven, the signal complies with the data sheet (Section 6.1.11).		
		If RESET is not to be driven, the pin is connected to VDD33 .		
Section 8.0, "Miscellaneous"		RBIAS resistor is 8.06 k Ω \pm 1.0%.		
		In layout, the ground flag is connected with at least nine vias in a square pattern.		
		In layout, gas blocking or venting techniques have been implemented in the ground flag vias.		
		In layout, the guidance of <i>AN26.21</i> and <i>AN18.15</i> has been followed.		
		The USB receptacle has a TID assigned by USB-IF.		

APPENDIX A: REVISION HISTORY

TABLE A-1: REVISION HISTORY

Revision Level & Date	Section/Figure/Entry	Correction
DS00004415A (02-24-22)	Initial release	

USB3341

THE MICROCHIP WEB SITE

Microchip provides online support via our WWW site at www.microchip.com. This web site is used as a means to make files and information easily available to customers. Accessible by using your favorite Internet browser, the web site contains the following information:

- **Product Support** – Data sheets and errata, application notes and sample programs, design resources, user's guides and hardware support documents, latest software releases and archived software
- **General Technical Support** – Frequently Asked Questions (FAQ), technical support requests, online discussion groups, Microchip consultant program member listing
- **Business of Microchip** – Product selector and ordering guides, latest Microchip press releases, listing of seminars and events, listings of Microchip sales offices, distributors and factory representatives

CUSTOMER CHANGE NOTIFICATION SERVICE

Microchip's customer notification service helps keep customers current on Microchip products. Subscribers will receive e-mail notification whenever there are changes, updates, revisions or errata related to a specified product family or development tool of interest.

To register, access the Microchip web site at www.microchip.com. Under "Support", click on "Customer Change Notification" and follow the registration instructions.

CUSTOMER SUPPORT

Users of Microchip products can receive assistance through several channels:

- Distributor or Representative
- Local Sales Office
- Field Application Engineer (FAE)
- Technical Support

Customers should contact their distributor, representative or Field Application Engineer (FAE) for support. Local sales offices are also available to help customers. A listing of sales offices and locations is included in the back of this document.

Technical support is available through the web site at: <http://microchip.com/support>

Note the following details of the code protection feature on Microchip products:

- Microchip products meet the specifications contained in their particular Microchip Data Sheet.
- Microchip believes that its family of products is secure when used in the intended manner, within operating specifications, and under normal conditions.
- Microchip values and aggressively protects its intellectual property rights. Attempts to breach the code protection features of Microchip product is strictly prohibited and may violate the Digital Millennium Copyright Act.
- Neither Microchip nor any other semiconductor manufacturer can guarantee the security of its code. Code protection does not mean that we are guaranteeing the product is “unbreakable”. Code protection is constantly evolving. Microchip is committed to continuously improving the code protection features of our products.

This publication and the information herein may be used only with Microchip products, including to design, test, and integrate Microchip products with your application. Use of this information in any other manner violates these terms. Information regarding device applications is provided only for your convenience and may be superseded by updates. It is your responsibility to ensure that your application meets with your specifications. Contact your local Microchip sales office for additional support or, obtain additional support at <https://www.microchip.com/en-us/support/design-help/client-support-services>.

THIS INFORMATION IS PROVIDED BY MICROCHIP "AS IS". MICROCHIP MAKES NO REPRESENTATIONS OR WARRANTIES OF ANY KIND WHETHER EXPRESS OR IMPLIED, WRITTEN OR ORAL, STATUTORY OR OTHERWISE, RELATED TO THE INFORMATION INCLUDING BUT NOT LIMITED TO ANY IMPLIED WARRANTIES OF NON-INFRINGEMENT, MERCHANTABILITY, AND FITNESS FOR A PARTICULAR PURPOSE, OR WARRANTIES RELATED TO ITS CONDITION, QUALITY, OR PERFORMANCE.

IN NO EVENT WILL MICROCHIP BE LIABLE FOR ANY INDIRECT, SPECIAL, PUNITIVE, INCIDENTAL, OR CONSEQUENTIAL LOSS, DAMAGE, COST, OR EXPENSE OF ANY KIND WHATSOEVER RELATED TO THE INFORMATION OR ITS USE, HOWEVER CAUSED, EVEN IF MICROCHIP HAS BEEN ADVISED OF THE POSSIBILITY OR THE DAMAGES ARE FORESEEABLE. TO THE FULLEST EXTENT ALLOWED BY LAW, MICROCHIP'S TOTAL LIABILITY ON ALL CLAIMS IN ANY WAY RELATED TO THE INFORMATION OR ITS USE WILL NOT EXCEED THE AMOUNT OF FEES, IF ANY, THAT YOU HAVE PAID DIRECTLY TO MICROCHIP FOR THE INFORMATION.

Use of Microchip devices in life support and/or safety applications is entirely at the buyer's risk, and the buyer agrees to defend, indemnify and hold harmless Microchip from any and all damages, claims, suits, or expenses resulting from such use. No licenses are conveyed, implicitly or otherwise, under any Microchip intellectual property rights unless otherwise stated.

Trademarks

The Microchip name and logo, the Microchip logo, Adaptec, AnyRate, AVR, AVR logo, AVR Freaks, BesTime, BitCloud, CryptoMemory, CryptoRF, dsPIC, flexPWR, HELDO, IGLOO, JukeBlox, KeeLoq, Klear, LANCheck, LinkMD, maXStylus, maXTouch, MediaLB, megaAVR, Microsemi, Microsemi logo, MOST, MOST logo, MPLAB, OptoLyzer, PIC, picoPower, PICSTART, PIC32 logo, PolarFire, Prochip Designer, QTouch, SAM-BA, SenGenuity, SpyNIC, SST, SST Logo, SuperFlash, Symmetricom, SyncServer, Tachyon, TimeSource, tinyAVR, UNI/O, Vectron, and XMEGA are registered trademarks of Microchip Technology Incorporated in the U.S.A. and other countries.

AgileSwitch, APT, ClockWorks, The Embedded Control Solutions Company, EtherSynch, Flashtec, Hyper Speed Control, HyperLight Load, IntelliMOS, Libero, motorBench, mTouch, Powermite 3, Precision Edge, ProASIC, ProASIC Plus, ProASIC Plus logo, Quiet-Wire, SmartFusion, SyncWorld, Temux, TimeCesium, TimeHub, TimePictra, TimeProvider, TrueTime, WinPath, and ZL are registered trademarks of Microchip Technology Incorporated in the U.S.A.

Adjacent Key Suppression, AKS, Analog-for-the-Digital Age, Any Capacitor, AnyIn, AnyOut, Augmented Switching, BlueSky, BodyCom, CodeGuard, CryptoAuthentication, CryptoAutomotive, CryptoCompanion, CryptoController, dsPICDEM, dsPICDEM.net, Dynamic Average Matching, DAM, ECAN, Espresso T1S, EtherGREEN, GridTime, IdealBridge, In-Circuit Serial Programming, ICSP, INICnet, Intelligent Paralleling, Inter-Chip Connectivity, JitterBlocker, Knob-on-Display, maxCrypto, maxView, memBrain, Mindi, MiWi, MPASM, MPF, MPLAB Certified logo, MPLIB, MPLINK, MultiTRAK, NetDetach, NVMe Express, NVMe, Omniscient Code Generation, PICDEM, PICDEM.net, PICkit, PICtail, PowerSmart, PureSilicon, QMatrix, REAL ICE, Ripple Blocker, RTAX, RTG4, SAM-ICE, Serial Quad I/O, simpleMAP, SimpliPHY, SmartBuffer, SmartHLS, SMART-I.S., storClad, SQI, SuperSwitcher, SuperSwitcher II, Switchtec, SynchroPHY, Total Endurance, TSHARC, USBCheck, VariSense, VectorBlox, VeriPHY, ViewSpan, WiperLock, XpressConnect, and ZENA are trademarks of Microchip Technology Incorporated in the U.S.A. and other countries.

SQTP is a service mark of Microchip Technology Incorporated in the U.S.A.

The Adaptec logo, Frequency on Demand, Silicon Storage Technology, Symmcom, and Trusted Time are registered trademarks of Microchip Technology Inc. in other countries.

GestIC is a registered trademark of Microchip Technology Germany II GmbH & Co. KG, a subsidiary of Microchip Technology Inc., in other countries.

All other trademarks mentioned herein are property of their respective companies.

© 2022, Microchip Technology Incorporated and its subsidiaries.

All Rights Reserved.

ISBN: 978-1-5224-9880-3

For information regarding Microchip's Quality Management Systems, please visit www.microchip.com/quality.



MICROCHIP

Worldwide Sales and Service

AMERICAS

Corporate Office
2355 West Chandler Blvd.
Chandler, AZ 85224-6199
Tel: 480-792-7200
Fax: 480-792-7277
Technical Support:
<http://www.microchip.com/support>
Web Address:
www.microchip.com

Atlanta

Duluth, GA
Tel: 678-957-9614
Fax: 678-957-1455

Austin, TX

Tel: 512-257-3370

Boston

Westborough, MA
Tel: 774-760-0087
Fax: 774-760-0088

Chicago

Itasca, IL
Tel: 630-285-0071
Fax: 630-285-0075

Dallas

Addison, TX
Tel: 972-818-7423
Fax: 972-818-2924

Detroit

Novi, MI
Tel: 248-848-4000

Houston, TX

Tel: 281-894-5983

Indianapolis

Noblesville, IN
Tel: 317-773-8323
Fax: 317-773-5453
Tel: 317-536-2380

Los Angeles

Mission Viejo, CA
Tel: 949-462-9523
Fax: 949-462-9608
Tel: 951-273-7800

Raleigh, NC

Tel: 919-844-7510

New York, NY

Tel: 631-435-6000

San Jose, CA

Tel: 408-735-9110
Tel: 408-436-4270

Canada - Toronto

Tel: 905-695-1980
Fax: 905-695-2078

ASIA/PACIFIC

Australia - Sydney
Tel: 61-2-9868-6733

China - Beijing
Tel: 86-10-8569-7000

China - Chengdu
Tel: 86-28-8665-5511

China - Chongqing
Tel: 86-23-8980-9588

China - Dongguan
Tel: 86-769-8702-9880

China - Guangzhou
Tel: 86-20-8755-8029

China - Hangzhou
Tel: 86-571-8792-8115

China - Hong Kong SAR
Tel: 852-2943-5100

China - Nanjing
Tel: 86-25-8473-2460

China - Qingdao
Tel: 86-532-8502-7355

China - Shanghai
Tel: 86-21-3326-8000

China - Shenyang
Tel: 86-24-2334-2829

China - Shenzhen
Tel: 86-755-8864-2200

China - Suzhou
Tel: 86-186-6233-1526

China - Wuhan
Tel: 86-27-5980-5300

China - Xian
Tel: 86-29-8833-7252

China - Xiamen
Tel: 86-592-2388138

China - Zhuhai
Tel: 86-756-3210040

ASIA/PACIFIC

India - Bangalore
Tel: 91-80-3090-4444

India - New Delhi
Tel: 91-11-4160-8631

India - Pune
Tel: 91-20-4121-0141

Japan - Osaka
Tel: 81-6-6152-7160

Japan - Tokyo
Tel: 81-3-6880-3770

Korea - Daegu
Tel: 82-53-744-4301

Korea - Seoul
Tel: 82-2-554-7200

Malaysia - Kuala Lumpur
Tel: 60-3-7651-7906

Malaysia - Penang
Tel: 60-4-227-8870

Philippines - Manila
Tel: 63-2-634-9065

Singapore
Tel: 65-6334-8870

Taiwan - Hsin Chu
Tel: 886-3-577-8366

Taiwan - Kaohsiung
Tel: 886-7-213-7830

Taiwan - Taipei
Tel: 886-2-2508-8600

Thailand - Bangkok
Tel: 66-2-694-1351

Vietnam - Ho Chi Minh
Tel: 84-28-5448-2100

EUROPE

Austria - Wels
Tel: 43-7242-2244-39
Fax: 43-7242-2244-393

Denmark - Copenhagen
Tel: 45-4485-5910
Fax: 45-4485-2829

Finland - Espoo
Tel: 358-9-4520-820

France - Paris
Tel: 33-1-69-53-63-20
Fax: 33-1-69-30-90-79

Germany - Garching
Tel: 49-8931-9700

Germany - Haan
Tel: 49-2129-3766400

Germany - Heilbronn
Tel: 49-7131-72400

Germany - Karlsruhe
Tel: 49-721-625370

Germany - Munich
Tel: 49-89-627-144-0
Fax: 49-89-627-144-44

Germany - Rosenheim
Tel: 49-8031-354-560

Israel - Ra'anana
Tel: 972-9-744-7705

Italy - Milan
Tel: 39-0331-742611
Fax: 39-0331-466781

Italy - Padova
Tel: 39-049-7625286

Netherlands - Drunen
Tel: 31-416-690399
Fax: 31-416-690340

Norway - Trondheim
Tel: 47-7288-4388

Poland - Warsaw
Tel: 48-22-3325737

Romania - Bucharest
Tel: 40-21-407-87-50

Spain - Madrid
Tel: 34-91-708-08-90
Fax: 34-91-708-08-91

Sweden - Gothenberg
Tel: 46-31-704-60-40

Sweden - Stockholm
Tel: 46-8-5090-4654

UK - Wokingham
Tel: 44-118-921-5800
Fax: 44-118-921-5820