



The Infinite Bandwidth Company™

MIC384 Evaluation Board

DemoWare™ Software

General Description

The Micrel MIC384 evaluation board and DemoWare Software demonstrate the operation and features of the MIC384 Three-Zone Thermal Supervisor. The MIC384 is a versatile digital thermal supervisor capable of measuring temperature using its internal sensor and two inexpensive external sensors or embedded silicon diodes such as those found in higher performance CPUs and FPGAs. This manual describes how to use the evaluation board and the companion software.

Getting Started

What is Included

Review the packing list in Table 1 to confirm that you received all listed items. If any of the items are missing or damaged, contact Micrel Semiconductor. The latest version of all Micrel data sheets may be obtained from our website at www.micrel.com.

Item	Qty	Description
1	1	MIC384 Evaluation Board with Jumpers Installed
2	1	MIC384 Evaluation Board and DemoWare Software Manual (this document)
3	1	MIC384 Data Sheet
4	2	MIC384BM Samples

Table 1. Packing List

What You Must Provide

If the board is to be used with the MIC384 DemoWare, no additional items are required except for a suitable host PC. All power for the board will be drawn from the PC parallel port. The board may be plugged directly into the DB25 connector on the host PC. It may be more convenient, however, to use a cable between the PC and the board. A standard, straight-through, DB25 male-to-female parallel printer cable may be used. If a non-PC host is used, the following items are required for use with the MIC384 evaluation board:

- 3.3V, 100mA regulated power supply
- Power supply leads or cables
- SMBus™/I²C™ compatible serial bus host for communication with the MIC384
- Cable for serial host connection, as appropriate

In either case, the following additional items are useful, but not required:

- Logic probe(s)
- Voltmeter(s)
- SMBus/I²C bus analyzer
- Component cooling spray
- Heat gun

General Description of the Evaluation Board

This board demonstrates use of the MIC384 Three-Zone Thermal Supervisor. It is designed to support rapid prototyping of circuits employing the MIC384. Two MMBT3906 transistors (surface mount equivalent to 2N3906) are included on the board in order to demonstrate the MIC384's ability to measure the temperature of remote PN junctions. A connector permits use of an off-board remote diode or transistor in place of either of the on-board remote transistors. User configurable jumpers select the MIC384's slave address and configure the remote sensor connections. An LED on the board reports the status of the interrupt request output, /INT. The LED may be disabled by opening a jumper.

For use with Micrel's DemoWare demonstration software, the MIC384 evaluation board may be connected directly to a PC parallel port via a DB25M connector. As an option, the user may install a 4-pin ACCESS.bus™-type connector to interface the evaluation board with a serial bus host such as the IPort™ I²C Host Adapter from MCC Corporation. An additional general-purpose 8-pin header can also be used to interface any I²C/SMBus host to the board.

DemoWare is a trademark of Micrel, Inc.
SMBus is a trademark of Intel Corporation.
I²C is a trademark of Philips Electronics N.V.
ACCESS.bus is a trademark of the ACCESS.bus Industry Group.
IPort is a trademark of Microcomputer Control Corporation.

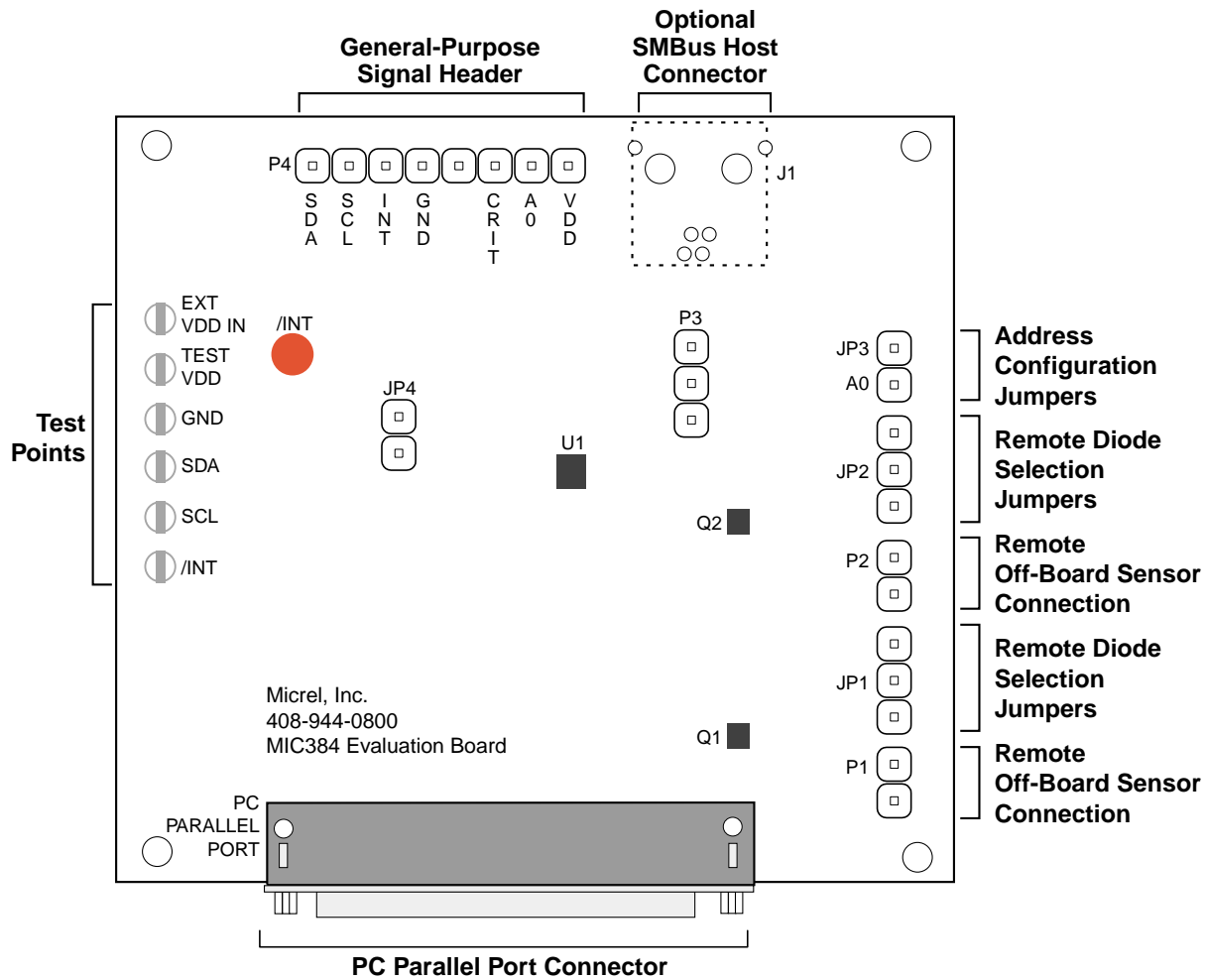

Figure 1. MIC384 Evaluation Board

Powering the Board

The MIC384 evaluation board can be powered via the host PC’s parallel printer port or an external power supply. Three options are available for powering the evaluation board.

Option 1: For use with Micrel’s DemoWare demonstration software and a host PC, connect the board to the PC’s parallel printer port via the DB-25M connector (refer to schematic in “Hardware Reference”). Pins 1 and 2 of P3 should be shorted.

Option 2: The board can be powered by an external power supply via TP1, “EXT VDD”, and TP2, “GND”. The positive connection should be made to TP1 and ground connection should be made to TP2. Pins 2 and 3 of P3 should be shorted.

Option 3: The board can be powered by a serial bus host such as the MCC IPort via optional user-installed 4-pin Molex connector J1. Pin 3 of this connector is assigned to carry the power supply voltage from the host (See Figure 2). Pins 2 and 3 of P3 should be shorted.

Serial Bus Host Connector

The optional user-installed SMBus host connector is Molex part #15-83-0064 shown in Figure 2. This Molex connector is a 4-conductor shielded receptacle. The pinout of this connector is shown below. The mating connector is a Molex part #15-83-1564. See Appendix A for more information on these connectors. The serial bus signals are also present on single-row header P4 and at test points TP4 and TP5. One or more of these connection points can be used in lieu of the specialized connector. The various serial bus connection points are summarized in Table 2.

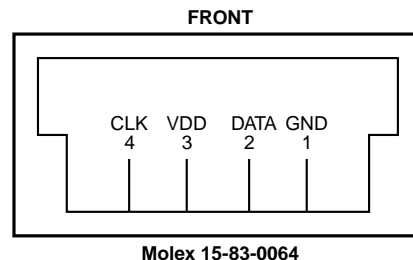

Figure 2. Pinout of J2 Serial Bus Host Connector

Signal	Molex 15-83-0064 Pin #	P4 Pin #	Test Point
Serial Data	2	1	TP5
Serial Clock	4	2	TP4
VDD	3	8	TP1
GND	1	4	TP2
/INT	N/A	3	TP6

Table 2. Serial Bus Connection Points

Personal computer based host adapters, cables, bus analyzers and other useful items can be obtained from the sources listed in Appendix A.

Slave Address Selection

The MIC384 slave address must be established for communication with the serial bus host. It is established by setting the address pin A0 to either logic '1' or logic '0'. Table 3 shows the jumper settings for selecting the slave address. The slave address of MIC384 is registered only during power-on and cannot be changed during operation. To change the MIC384 slave address, remove power, establish the new slave address and then reapply power.

Remote Diode Selection

The MIC384 senses the temperatures of remote PN junction connected to the T1 pin and T2 pin. This PN junction is generally either a diode-connected bipolar junction transistor or the embedded thermal diode inside an integrated circuit. Diode-connected 2N3906-type transistors, Q1 and Q2, are provided on the evaluation board. Header P1 and P2 can be used to connect to an off-board diode. Jumper JP1 selects between Q1 and the sensor connected to P1. Similarly jumper JP2 selects between Q2 and the sensor connected to P2. (Refer to Table 3.)

Figure 3 shows several examples of remote diode connections. To minimize noise pickup, connections to an off-board diode should be made using twisted-pair or shielded twisted-pair cable. Connections longer than a few inches or any connection in an electrically noisy environment should use shielded twisted-pair cable for optimal performance. (Note that the shield should be grounded only at P1/P2 on the evaluation board.) Suitable cable types include Belden's part number 8442 unshielded twisted-pair (UTP) and Belden's part number 8451 shielded twisted-pair (STP).

If using a transistor, the base and collector should be shorted together *at the transistor*. The emitter and base-collector terminals are then connected to P1/P2. The emitter is connected to pin 2 of P1/P2; the base-collector junction should be connected to pin 1 of P1/P2.

LED Indicator

The LED on the evaluation board indicates the state of the /INT output. When an interrupt is generated by the MIC384, the signal at the /INT output pin goes from high to low. This causes the /INT LED to turn on. The /INT LED will turn off once the interrupt gets cleared. The LED indicator can be deactivated by opening jumper JP4. JP4 enables the /INT LED when shorted; opening the jumper disables the LED.

Factory Settings

The slave address is set to 1001000b=48h and remote on-board diodes Q1 and Q2 are connected to T1 and T2 respectively.

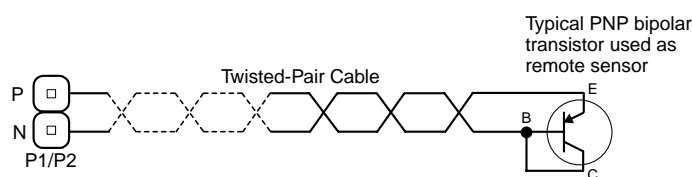

Figure 3a. Remote Diode Connections via P1/P2

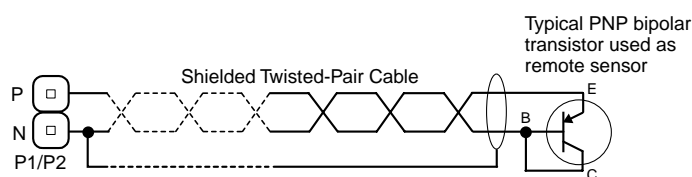

Figure 3b. Remote Diode Connections via P1/P2

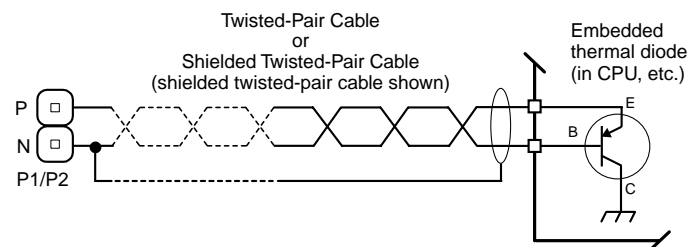

Figure 3c. Remote Diode Connections via P1/P2

Jumper Settings			Sensor		MIC384 Slave Address	
JP1	JP2	JP3	T1	T2	Binary	Hex
2-3	2-3	Shorted	Q1	Q2	100 1000 _b	48 _h
1-2	2-3	Shorted	Off-board via P1	Q2	100 1000 _b	48 _h
2-3	1-2	Shorted	Q1	Off-board via P2	100 1000 _b	48 _h
1-2	1-2	Shorted	Off-board via P1	Off-board via P2	100 1000 _b	48 _h
2-3	2-3	Open	Q1	Q2	100 1001 _b	49 _h
1-2	2-3	Open	Off-board via P1	Q2	100 1001 _b	49 _h
2-3	1-2	Open	Q2	Off-board via P2	100 1001 _b	49 _h
1-2	1-2	Open	Off-board via P1	Off-board via P2	100 1001 _b	49 _h

Table 3. MIC384 Slave Address Configuration

Pull-up Resistors

The MIC384 evaluation board includes a 4.7k Ω pull-up resistor on the serial data line and the serial clock line, and a 22k Ω resistor on the MIC384's /INT output. When using a serial bus host such as the IPort, the host's pull-up resistors should be deactivated.

Hardware Reference

Terminals

Designator	Description
P3	V _{DD} selection jumper
P4	General purpose signal header
P1	Off-board remote sensor connection
P2	Off-board remote sensor connection
P5	Parallel port connector, DB25M PC, for use with Micrel DemoWare software
J1	Serial bus host connector, 4-pin

Test Points

Designator	Description
TP1	EXTERNAL V _{DD} IN
TP2	GROUND
TP3	V _{DD} TEST
TP4	SERIAL CLOCK
TP5	SERIAL DATA
TP6	INTERRUPT

Jumper Options

Jumper	Position	Function	Factory Setting
JP4	Shorted Open	Enables /INT LED Disables /INT LED	Shorted
JP3	Shorted Open	A0 = 0 A0 = 1	Shorted
JP2	1 - 2 2 - 3	Off-board transistor/diode is used as remote sensor via P2 On-board transistor Q2 is used as remote sensor	Open Shorted
JP1	1 - 2 2 - 3	Off-board transistor/diode is used as remote sensor via P1 On-board transistor Q1 is used as remote sensor	Open Shorted
P3	1 - 2 2 - 3	Use V _{DD} from PC parallel port Use V _{DD} from external V _{DD} input or V _{DD} from serial bus host	Shorted

*Pin number one of each header is denoted by a square pad on the PCB versus a round pad for all other pins. The pads are visible on the back side of the printed circuit board.

Bill of Materials

Item	Part Number	Manufacturer	Description	Qty.
C1	ECS-F1CE225K	Panasonic - ECG	2.2 μ F, 10V, tantalum capacitor	1
C2	ECU-S1H104KBB	Panasonic - ECG	0.1 μ F, 50V, 20% ceramic capacitor	1
C3	ECS-F1CE475K	Panasonic - ECG	4.7 μ F, 10V tantalum capacitor	1
C4	K222J15C0GF5TL2	BC Components	2200pF, 50V, 5% ceramic capacitor	1
C5	K222J15C0GF5TL2	BC Components	2200pF, 50V, 5% ceramic capacitor	1
D1	BAT85	Diodes Inc.	Schottky diode, 40V, 400mW, D0-35	1
D2	BAT85	Diodes Inc.	Schottky diode, 40V, 400mW, D0-35	1
D3	BAT85	Diodes Inc.	Schottky diode, 40V, 400mW, D0-35	1
D4	BAT85	Diodes Inc.	Schottky diode, 40V, 400mW, D0-35	1
D5	BAT85	Diodes Inc.	Schottky diode, 40V, 400mW, D0-35	1
J1	15-84-0064	Molex	SMBus host connector	1
JP1	Any	Any	3-pin header	1
JP2	Any	Any	3-pin header	1
JP3	Any	Any	2-pin header	1
JP4	Any	Any	2-pin header	1
JP5	N/A	N/A	Not stuffed	N/A
JP6	N/A	N/A	Not stuffed	N/A
JP7	ZOR-25-B	Yageo	0 Ω 1/4W, 5% resistor	1
P1	Any	Any	2-pin header	1
P2	Any	Any	2-pin header	1
P3	Any	Any	3-pin header	1
P4	Any	Any	8-pin header	1
P5	DB25M	Any	Male parallel port connector	1
/INT	LTL-4203	Lite-On Inc.	Red LED	1
/CRIT	N/A	N/A	Not stuffed	N/A
Q1	2N3906	Motorola	PNP transistor, TO-92	1
Q2	2N3906	Motorola	PNP transistor, TO-92	1
Q3	2N3906	Motorola	PNP transistor, TO-92	1
Q4	N/A	N/A	Not stuffed	N/A
R1	N/A	N/A	Not stuffed	N/A
R2	CFR-25JB-22K	Yageo	22k Ω 1/4W, 5% resistor	1
R3	CFR-25JB-4K7	Yageo	4.7k Ω 1/4W, 5% resistor	1
R4	CFR-25JB-4K7	Yageo	4.7k Ω 1/4W, 5% resistor	1
R5	CFR-25JB-100K	Yageo	100k Ω , 1/4W, 5% resistor	1
R6	CFR-25JB-100R	Yageo	100 Ω 1/4W, 5% resistor	1
R7	CFR-25JB-22K	Yageo	22k Ω 1/4W, 5% resistor	1
R8	CFR-25JB-470R	Yageo	470 Ω 1/4W, 5% resistor	1
R9	N/A	N/A	Not stuffed	N/A
R10	N/A	N/A	Not stuffed	N/A
EXT VDD	5007	Keystone Electronics	Color coded PCB test points, white	1
VDD TEST	5007	Keystone Electronics	Color coded PCB test points, white	1
GND	5006	Keystone Electronics	Color coded PCB test points, black	1
SDA	5007	Keystone Electronics	Color coded PCB test points, white	1
SCL	5007	Keystone Electronics	Color coded PCB test points, white	1
/INT	5007	Keystone Electronics	Color coded PCB test points, white	1
/CRIT	N/A	N/A	Not stuffed	N/A
U1	MIC384-0BM	Micrel Semiconductor	Local/Remote Thermal Supervisor	1
U2	MIC5207-3.3BZ	Micrel Semiconductor	180mA Low Noise LDO Regulator	1

PC Board Layout

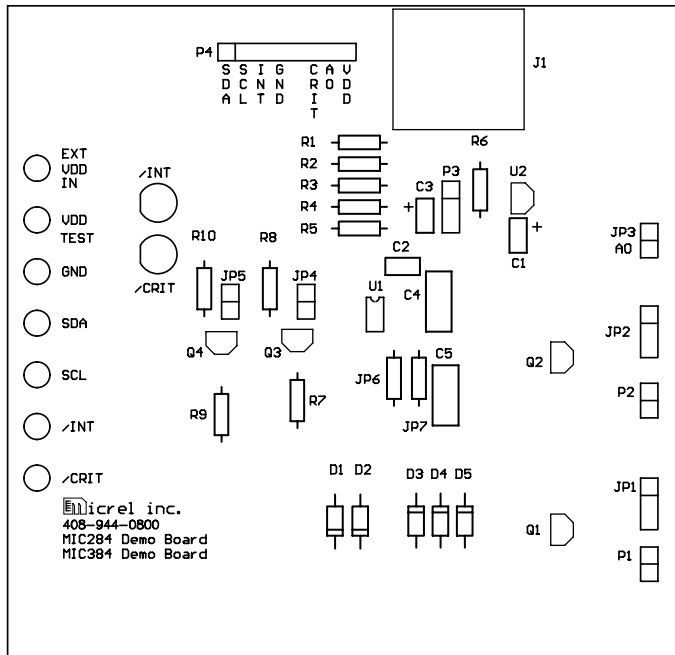

PC Board Layout - Top Silkscreen

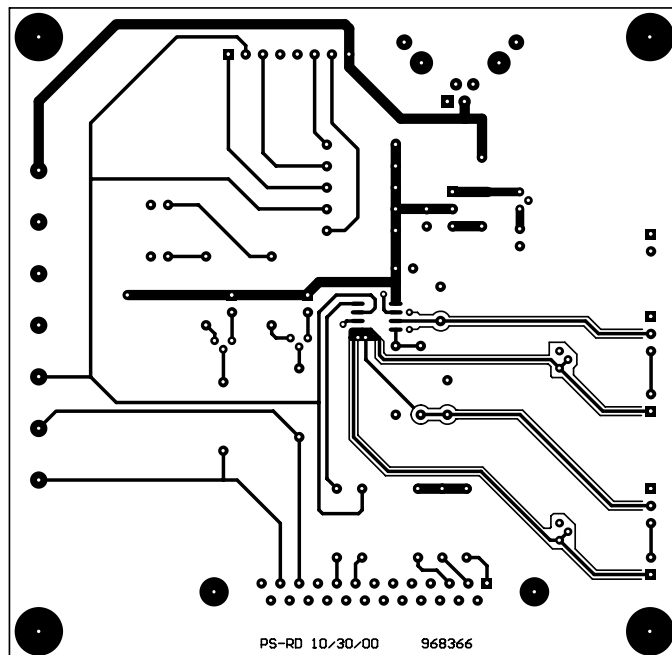

PC Board Layout - Top

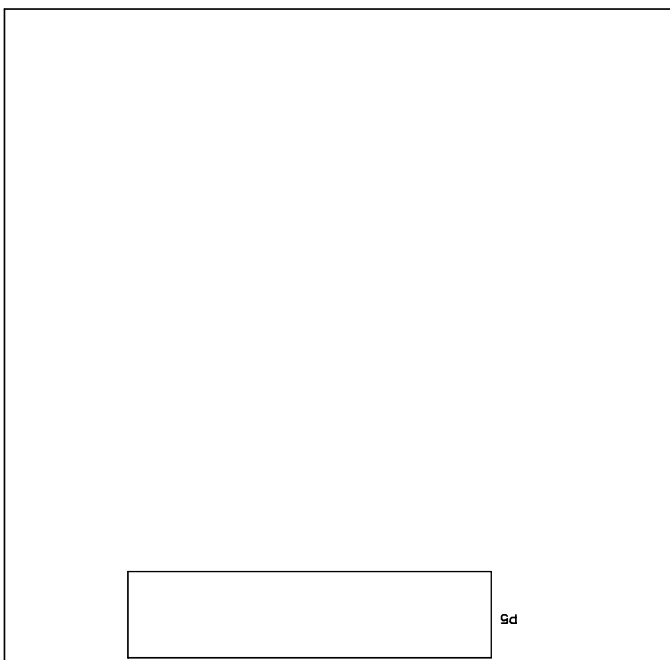

PC Board Layout - Bottom Silkscreen

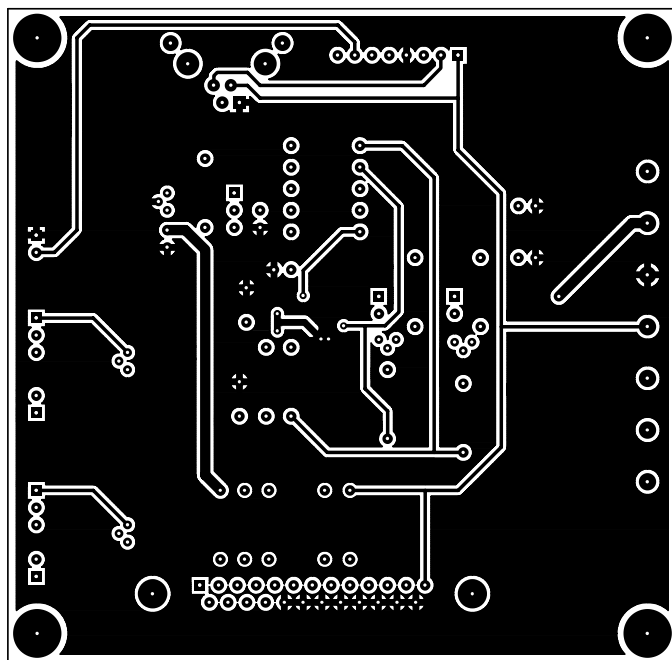

PC Board Layout - Bottom

MIC384 DemoWare™ Software

System Requirements

The DemoWare software is designed to run on any personal computer running Microsoft Windows 95 or 98. A standard parallel printer port is required for communication with the MIC384 evaluation board. Once decompressed and installed, the DemoWare files will occupy approximately 1.9MB of hard disk space.

Installing the Software

The MIC384 DemoWare is available for download at <http://www.micrel.com>. If you are unable to obtain the software from the Micrel website, please contact a Micrel sales representative for assistance. To install the MIC384 DemoWare:

1. Download the file "MIC1_2_384-demoware.exe" into a temporary directory. This file is a self-extracting ZIP archive containing the files *MIC1_2_384-demoware.exe* and *Mfc42.dll*. *MIC1_2_384-demoware.exe* is the program itself. *Mfc42.dll* is a library containing code used by *MIC1_2_384-demoware.exe*.
2. Start the extraction process by selecting **Run** on the **Start** menu and choosing the file *MIC1_2_384-demoware.exe*. *MIC1_2_384-demoware.exe* and *Mfc42.dll* will be extracted and saved into a subdirectory named *MICx84DemoWare* in the root directory of the hard disk. If you wish to use a different directory, enter its name in the "Unzip to folder" text box or select the **Browse** option. This directory will be created if necessary.
3. Select "Unzip" and the files will be extracted.
4. A message stating "2 file(s) unzipped successfully" will be displayed when the process is finished. Click "OK" to proceed.
5. Click "Close" to complete the process and exit the installation utility.

Running the Software

Launch the software by selecting **Run** on the **Start** menu and selecting the file *MIC1_2_384-demoware.exe*. If the installation defaults were used, this file will be in a subdirectory called "MICx84DemoWare" in the root directory on the hard disk. Once the program starts, the main window will be displayed and power to the evaluation board will be off. Any status or error messages displayed are not valid until the software is properly configured and the board is powered on.

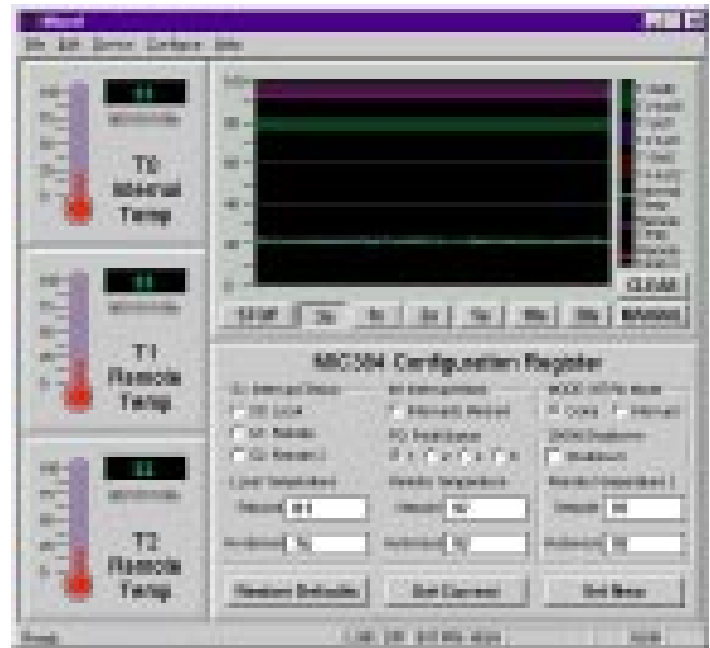

Figure 4. MIC384 DemoWare Main Window

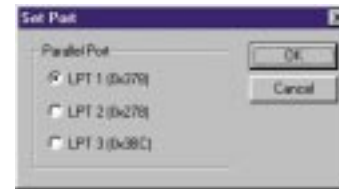

Figure 5. Selecting the Printer Port



Figure 6. Selecting the Device Type and Base Address



Figure 7. Selecting the Chart Recorder Scale



Figure 8. Turning on Power to the Evaluation Board

Using the Software

The software must be configured prior to use:

1. Select the printer port to which the board will be connected using the **Port** item on the **Configure** Menu as shown in Figure 5.
2. Select the MIC384 device by selecting **MIC384** on the Device menu. Select the device base address using the **Device** item on the **Configure** menu as shown in Figure 6. The base address selected must match the jumper settings on the evaluation board as shown in Table 3.
3. Adjust the chart recorder scale using the **Scale** item on the **Configure** menu. Only temperature values between **Upper Scale Limit** and **Lower Scale Limit** will be displayed in the chart recorder window. Enter the desired values in the text boxes.

Clicking the **Get Current** button or any of the temperature acquisition buttons will automatically turn on power to the board. The power may also be turned on using the **Device Power** item on the **Configure** menu, as shown in Figure 8. When power is on, a checkmark will appear next to **Device Power** on the **Configure** menu. (In any case, the power should be turned off before removing the board from the PC by selecting the **Device Power** item on the **Configure** menu!)

Once power is turned on, the MIC384 registers will be read and the current values will be displayed. The main window should now appear similar to Figure 4.

The main window has several components:

- Temperature acquisition buttons and chart recorder (Figure 11): A single temperature sample from the selected zone may be taken by clicking the **MANUAL** button. Automatic temperature samples can be taken at specific intervals by clicking the **.5s**, **1s**, **2s**, **5s**, **10s**, or **20s** button. Any temperature samples taken will be displayed in the chart recorder area. Data for Zone 0, the internal zone, will be plotted in green, data for Zone 1, the first external zone, will be plotted in blue, and data for Zone 2, the second external zone, will be plotted in red.
- Status line (Figure 10): Status messages are displayed on the status line, including the state of the serial bus link, the logic state of the /INT pin, and the states of the Shift Lock and Num Lock keys.
- Thermometer display (Figure 9): The three thermometers will be active and display the reported temperature for each zone in degrees Centigrade and binary. Alarm indications are also displayed in the thermometer display.

- Register display (Figure 12): The values in the configuration, setpoint, and hysteresis registers are displayed in this box. The bits of the configuration register are displayed according to function. Those bits that are not read-only can be altered. New values can be entered in the appropriate text boxes. Merely changing the values displayed on the screen will not cause data to be written to the MIC384. *The **Set New** button must always be used to write any changes to the part.*

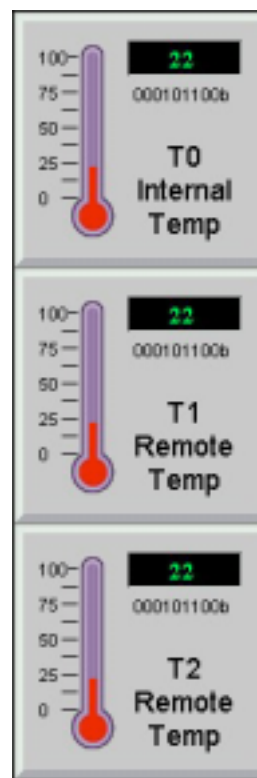

Figure 9. Thermometer Displays



Figure 10. Status Line

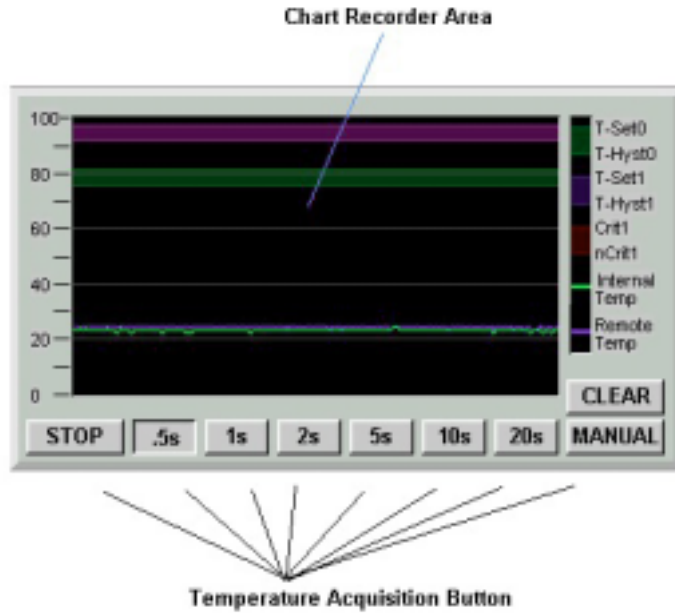

Figure 11. Temperature Acquisition Window

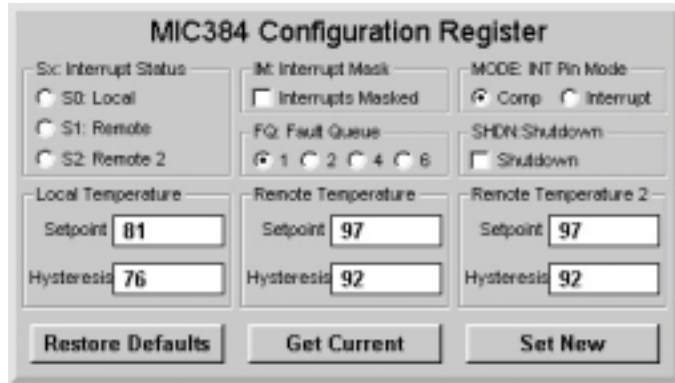

Figure 12. Register Display

Acquiring Temperature Data

Single Conversions

Clicking the **MANUAL** button will cause a single temperature reading to be acquired from the selected zone. This single reading will be displayed on the appropriate thermometer display and plotted on the chart recorder in the appropriate color. It will also be recorded to the log file if data logging is turned on. See "Logging Data to a File" below.

Periodic Sampling

Clicking any one of **.5s** or **1s** or **2s** or **5s** or **10s** or **20s** buttons will initiate repetitive temperature sampling at the indicated interval. The data acquired will be displayed on the appropriate thermometer display and plotted on the chart recorder in the appropriate color. The samples will also be recorded to the log file if data logging is turned on.

Viewing and Modifying Registers

Get Current

The current values of the configuration, setpoint, and hysteresis registers can be displayed at any time by clicking the **Get Current** button.

Setpoint and Hysteresis Registers

The temperature setpoint and hysteresis registers can be modified by typing the desired values into the **Temperature Setpoint** and **Hysteresis** text boxes for each zone and then clicking the **Set New** button. *The **Set New** button must always be used to write new values to the MIC384 after any setting is modified on the screen.*

Configuration Register

The various functions of the configuration register can be accessed using the check boxes and radio buttons in the **MIC384 Configuration Register** section of the main window. The **Set New** button must always be used to write new values to the MIC384 after any setting is modified on the screen.

Restoring Register Defaults

Clicking the **Restore Defaults** button will return all registers to their default values, similar to the MIC384's power-on state.

Logging Data to a File

All temperature data acquired during a given period may be logged to a file by activating the recording function. Recording is started by selecting the **Record to File...** item on the File menu.

1. Configure the device as desired via the register display window.
2. Click **Set New** to update the MIC384's configuration.
3. Activate data logging by selecting the **Record to File...** item on the **File** menu. Enter the desired file and path name and click **Save**. Note that the log file is a comma-delimited or *.csv file.
4. Acquire temperature data by clicking the **.5s**, **1s**, **2s**, **5s**, **10s**, **20s**, or **MANUAL** button.
5. When finished recording data, stop data logging by once again selecting the **Record to File...** item on the **File** menu.

Micrel Data Log File created 10/29/2001 15:17:09

DATE	TIME	ELAPSED	SAMPLE	INTERNAL	REMOTE1	REMOTE2
10/29/01	15:17:10	0	0	22	22	23
10/29/01	15:17:10	630	1	21	22	23
10/29/01	15:17:11	1145	2	22	22	23
10/29/01	15:17:11	1680	3	22	22	23
10/29/01	15:17:12	2200	4	22	22	23
10/29/01	15:17:12	2720	5	22	22	23
10/29/01	15:17:13	3240	6	22	22	23
10/29/01	15:17:13	3760	7	22	22	23
10/29/01	15:17:14	4275	8	22	23	23
10/29/01	15:17:15	4790	9	22	23	23
10/29/01	15:17:15	5305	10	22	23	23
10/29/01	15:17:16	5825	11	22	23	23
10/29/01	15:17:16	6340	12	23	23	23
10/29/01	15:17:17	6860	13	23	23	23
10/29/01	15:17:17	7375	14	24	25	24
10/29/01	15:17:18	7891	15	24	25	24
10/29/01	15:17:18	8405	16	24	24	24
10/29/01	15:17:19	8920	17	24	24	25
10/29/01	15:17:19	9435	18	24	25	25
10/29/01	15:17:20	9950	19	25	26	25
10/29/01	15:17:20	10470	20	25	25	25
10/29/01	15:17:21	10985	21	25	25	25

Figure 13. Example Data Log

An example data file is shown in Figure 13. This file may be opened in a program such as Microsoft Excel for graphing, filtering, sorting, manipulation, etc. The first line of the file identifies the file and the time and date when it was created. The second line lists the field names for the succeeding lines. The fields are as follows (in order):

- **DATE:** The date, according to the PC's system clock, that the sample was taken.
- **TIME:** The time, according to the PC's system clock, that the sample was taken.
- **ELAPSED:** The total elapsed time, in milliseconds, since the first sample was taken.
- **SAMPLE:** The sample number; samples are numbered sequentially starting with number one.
- **INTERNAL:** The measured temperature for the internal zone.
- **REMOTE1:** The measured temperature for the first remote zone, Zone 1.
- **REMOTE2:** The measured temperature for the second remote zone, Zone 2.

Appendix A: SMBus Resources*

PC host adapters and software, bus analyzers, cables, and other items can be purchased from:

Micro Computer Control Corporation

PO Box 275/ 17 Model Ave.
Hopewell, New Jersey 08525 USA
Tel.: 609-466-1751
Email: info@mcc-us.com
<http://www.mcc-us.com>

Saelig Company

Tel.: 716-425-3753
Fax: 716-425-3835
Email: saelig@aol.com
<http://www.memo.com/saelig>

The 4-conductor serial bus connector is available from Molex as part number 15-83-0064. Mating plugs for constructing cable assemblies are also available. A list of distributors is available on the Molex website.

Molex Incorporated

2222 Wellington Court
Lisle, IL 60532-1682
Tel.: 800-78MOLEX,
630-969-4550 (Outside USA)
Fax: 630-968-8356
Telex: 254069
E-mail: amerinfo@molex.com
<http://www.molex.com>

The current SMBus specification and other information regarding SMBus may be obtained from the SMBus website <http://www.smbus.org>.

*Micrel does not necessarily endorse or recommend any of the products, services, or information sources listed above. Micrel is not affiliated in any way with any listed company, person, or other entity. The above information is presented without warranty of any kind.

MICREL INC. 1849 FORTUNE DRIVE SAN JOSE, CA 95131 USA

TEL + 1 (408) 944-0800 FAX + 1 (408) 944-0970 WEB <http://www.micrel.com>

This information is believed to be accurate and reliable, however no responsibility is assumed by Micrel for its use nor for any infringement of patents or other rights of third parties resulting from its use. No license is granted by implication or otherwise under any patent or patent right of Micrel Inc.

© 2002 Micrel Incorporated