

BM83 Host MCU Firmware Development Guide

Introduction

IS2083/BM83 supports two modes of operation:

1. Embedded Mode
In this mode, external microcontroller (MCU) is not required. The Multi-Speaker (MSPK) firmware on the IS2083 MCU performs application specific controls.
2. Host Mode
Requires an external MCU for application-specific system control. The Host MCU can control IS2083BM/BM83 through UART command set.

This document describes the host MCU reference code for Microchip's Bluetooth® Multi-Speaker solution in Host mode. It includes demo introductions, hardware connection, UART command set, and source code explanation.

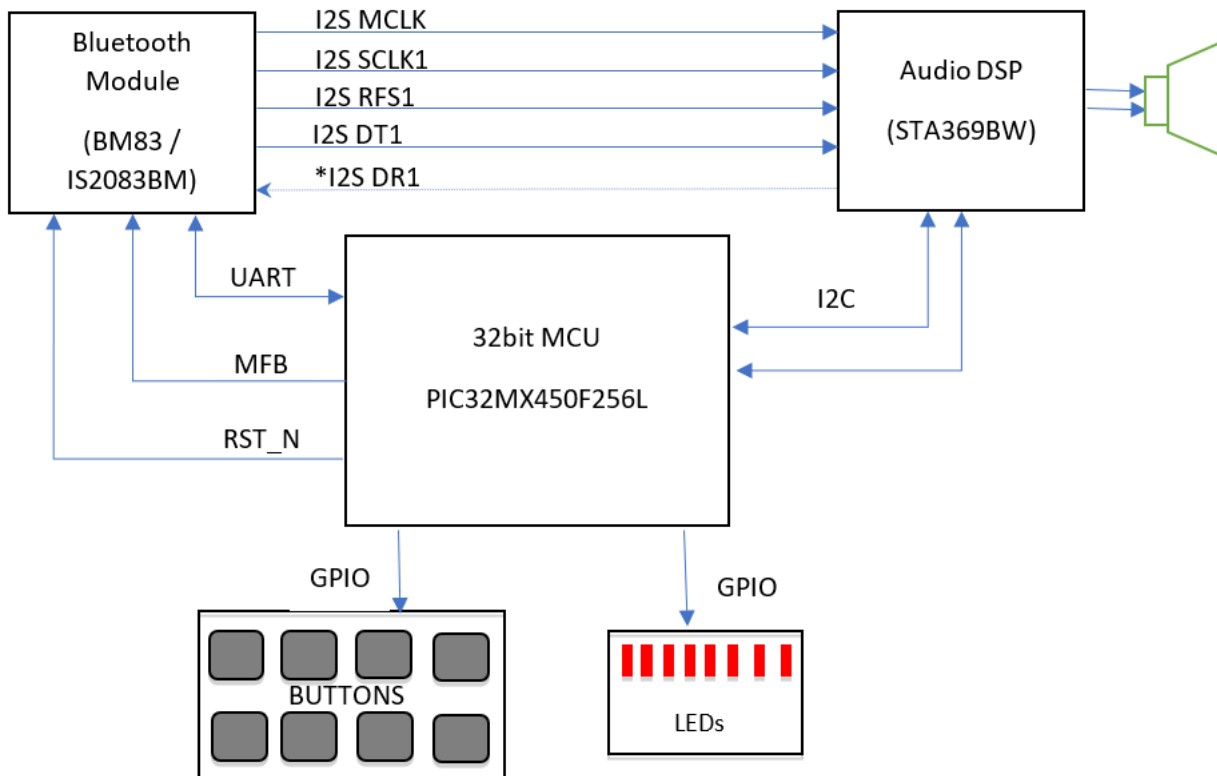

Note: STA369BW does not support I2S data transmit (I2S DR1).

Table of Contents

Introduction	1
1. Installing Source Code to MHC.....	6
2. Installing and Using MHC.....	7
3. Hardware Requirements.....	12
4. Using Bluetooth Speaker Basic Demo Application.....	13
4.1. Source Code Architecture and Project Files.....	13
4.2. Host MCU Application Elements.....	14
4.3. Event and Event Handler.....	18
4.4. Sending Command and Command APIs.....	22
4.5. SPP/IAP/BLE Data Process.....	23
4.6. Power On and Power Off Process.....	24
4.6.1. Reset process.....	25
4.6.2. Power-on Process.....	26
4.6.3. Power-off Process.....	26
4.7. Buttons.....	27
5. UART Communication Protocol.....	29
5.1. Connections Between BM83 and PIC 32 MCU.....	29
5.2. UART Command and Event Format.....	29
5.3. UART Protocol.....	30
5.4. UART Packet Process Rule.....	31
5.4.1. Command Packet Handling.....	31
5.4.2. Event Packet Handling.....	32
5.5. MFB Control.....	33
5.6. UART Commands.....	33
5.6.1. Make_Call (0x00).....	35
5.6.2. Make_Extension_Call (0x01).....	36
5.6.3. Event_Filter_Setting (0x03).....	37
5.6.4. Music_Control (0x04).....	39
5.6.5. Change_Device_Name (0x05).....	40
5.6.6. Change_PIN_Code (0x06).....	40
5.6.7. BTM_Parameter_Setting (0x07).....	41
5.6.8. Read_BTM_Version (0x08).....	43
5.6.9. Vendor_AT_Cmd (0x0A)	43
5.6.10. AVC_Vendor_Dependent_Cmd (0x0B)	44
5.6.11. AVC_Group_Navigation (0x0C)	45
5.6.12. Read_Link_Status (0x0D)	46
5.6.13. Read_Paired_Device_Record (0x0E)	46
5.6.14. Read_Local_BD_Address (0x0F)	47
5.6.15. Read_Local_Device_Name (0x10)	47
5.6.16. Send_SPP/iAP_Or_LE_Data (0x12)	47
5.6.17. BTM_Utility_Function (0x13)	49
5.6.18. Event_Ack (0x14)	54

5.6.19.	Additional_Profile_Link_Setup (0x15)	55
5.6.20.	Read_Linked_Device_Information (0x16)	55
5.6.21.	Profile_Link_Back (0x17)	56
5.6.22.	Disconnect (0x18)	57
5.6.23.	User_Confirm_SSP_Req_Reply (0x1A)	58
5.6.24.	Set_HF_Speaker_Gain_Level (0x1B)	59
5.6.25.	EQ_Mode_Setting (0x1C)	60
5.6.26.	DSP_NR_CTRL (0x1D)	60
5.6.27.	GPIO_CTRL (0x1E)	61
5.6.28.	MCU_UART_Rx_Buffer_Size (0x1F)	64
5.6.29.	Voice_Prompt_Cmd (0x20)	64
5.6.30.	Set_Overall_Gain (0x23)	65
5.6.31.	Read_BTM_Setting (0x24)	67
5.6.32.	Read_BTM_Battery_Charger_Status (0x25)	68
5.6.33.	MCU_Update_Cmd (0x26)	68
5.6.34.	Report_Battery_Capacity (0x27)	69
5.6.35.	LE_ANCS_Service_Cmd (0x28)	69
5.6.36.	LE_Signaling_Cmd (0x29)	71
5.6.37.	nSPK_Vendor_Cmd (0x2A)	73
5.6.38.	Read_nSPK_Link_Status (0x2B)	74
5.6.39.	nSPK_Sync_Audio_Effect (0x2C)	74
5.6.40.	LE_GATT_CMD (0x2D)	75
5.6.41.	LE_App_Cmd (0x2F)	78
5.6.42.	DSP_Runtime_Program (0x30)	79
5.6.43.	Read_Vendor_Eeprom_Data (0x31)	80
5.6.44.	Read_IC_Version_Info (0x32)	80
5.6.45.	Voice_Prompt_Ind_Cmd (0x33)	81
5.6.46.	Read_BTM_Link_Mode (0x34)	82
5.6.47.	Configure_Vendor_Parameter (0x35)	82
5.6.48.	nSPK Exchange_Link_Info_Cmd (0x37)	83
5.6.49.	nSPK Set GIAC(0x38)	84
5.6.50.	READ_FEATURE_LIST (0x39)	84
5.6.51.	Personal_MSPK_GROUP_Control (0x3A)	84
5.6.52.	UART_CMD_TEST_DEVICE (0x3B)	85
5.6.53.	PBAPC_Cmd(0x3F)	85
5.6.54.	AVRCP_Browsing_Cmd (0x41)	99
5.6.55.	MMI_Action UART Command (0x02)	107
5.7.	UART Events	131
5.7.1.	Command_Ack (0x00)	133
5.7.2.	BTM_Status (0x01)	134
5.7.3.	Call_Status (0x02)	137
5.7.4.	Caller_ID (0x03)	137
5.7.5.	SMS_Received_Indication (0x04)	138
5.7.6.	Missed_Call_Indication (0x05)	138
5.7.7.	Phone_Max_Battery_Level (0x06)	139
5.7.8.	Phone_Current_Battery_Level (0x07)	139
5.7.9.	Roaming_Status (0x08)	140
5.7.10.	Phone_Max_Signal_Strength_Level (0x09)	140

5.7.11.	Phone_Current_Signal_Strength_Level (0x0A).....	141
5.7.12.	Phone_Service_Status (0x0B).....	141
5.7.13.	BTM_Battery_Status (0x0C).....	141
5.7.14.	BTM_Charging_Status (0x0D).....	142
5.7.15.	Reset_To_Default (0x0E).....	143
5.7.16.	Report_HF_Gain_Level (0x0F).....	144
5.7.17.	EQ_Mode_Indication (0x10).....	144
5.7.18.	Read_Linked_Device_Information_Reply (0x17).....	145
5.7.19.	Read_BT_M_Version_Reply (0x18).....	146
5.7.20.	Call_List_Report (0x19).....	147
5.7.21.	AVC_Vendor_Dependent_Response (0x1A).....	148
5.7.22.	BTM_Utility_Req (0x1B).....	149
5.7.23.	Vendor_AT_Cmd_Rsp (0x1C).....	152
5.7.24.	Report_Vendor_AT_Event (0x1D).....	153
5.7.25.	Read_Link_Status_Reply (0x1E).....	153
5.7.26.	Read_Paired_Device_Record_Reply (0x1F).....	154
5.7.27.	Read_Local_BD_Address_Reply (0x20).....	155
5.7.28.	Read_Local_Device_Name_Reply (0x21).....	155
5.7.29.	Reprt_SPP/iAP/LE_Data (0x22).....	155
5.7.30.	Reprt_Link_Back_Status (0x23).....	156
5.7.31.	Ringtone_Status_Indication (0x24).....	157
5.7.32.	User_Confirm_SSP_Req (0x25).....	158
5.7.33.	Report_AVRCP_Volume_Ctrl (0x26).....	158
5.7.34.	Report_Input_Signal_Level (0x27).....	159
5.7.35.	Report_iAP_Info (0x28).....	160
5.7.36.	Report_AVRCP_ABS_Volume_Level (0x29).....	161
5.7.37.	Report_Voice_Prompt_Status (0x2A).....	161
5.7.38.	Report_Type_Codec (0x2D).....	162
5.7.39.	Report_Type_BT_M_Settings (0x2E).....	163
5.7.40.	Report_MCU_Update_Reply (0x2F).....	164
5.7.41.	Report_BT_M_Initial_Status (0x30).....	164
5.7.42.	LE_ANCS_Service_Event (0x31).....	164
5.7.43.	LE_Signaling_Event (0x32).....	166
5.7.44.	Report_nSPK_Link_Status (0x33).....	168
5.7.45.	Report_nSPK_Vendor_Event (0x34).....	169
5.7.46.	Report_nSPK_Audio_Setting (0x35).....	170
5.7.47.	Report_Sound_Effect_Status (0x36).....	171
5.7.48.	Report_Vendor_EEPROM_Data (0x37).....	171
5.7.49.	Report_IC_Ver_Info (0x38).....	172
5.7.50.	REPORT_LE_GATT_EVENT (0x39).....	173
5.7.51.	Report_BT_M_Link_Mode (0x3A).....	176
5.7.52.	DSP_Dedicated_Event (0x3B).....	177
5.7.53.	Report_nSPK_MISC_Event (0x3C).....	177
5.7.54.	Report_nSPK_Exchange_Link_info (0x3D).....	178
5.7.55.	Report_Customized_Information (0x3E).....	179
5.7.56.	Report_CSB_CLK (0x3F).....	179
5.7.57.	Report_Read_Feature_List_Reply (0x40).....	179
5.7.58.	REPORT_TEST_RESULT_REPLY (0x41).....	180

5.7.59. Report_Read_EEPROM_Data (0x42).....	181
5.7.60. PBAPC_Event (0x43).....	181
5.7.61. AVRCP_Browsing_Event (0x44).....	189
6. Document Revision History.....	202
The Microchip Website.....	203
Product Change Notification Service.....	203
Customer Support.....	203
Microchip Devices Code Protection Feature.....	203
Legal Notice.....	203
Trademarks.....	204
Quality Management System.....	204
Worldwide Sales and Service.....	205

1. Installing Source Code to MHC

The BM83 EVB uses PIC32MX450F256L as Host MCU. The Host MCU reference code (BT_Speaker_Basic_Demo) for BM83 is developed on MPLAB® Harmony.

To understand all the functions and develop new feature based on source code, it is recommended to install Microchip Harmony v1.09.

Perform the following steps to install the BM83 BT_Speaker_Basic_Demo into the MPLAB Harmony Configurator (MHC):

1. Download and install Harmony v1.09 from the following links:
 - For Windows®: [MPLAB® Harmony Integrated Software Framework v1.09](#)
 - For Mac®: [MPLAB® Harmony Integrated Software Framework v1.09](#)
2. Specify the installation directory as C:\microchip\harmony\v1_09\.
3. After installation is complete, in the C:\microchip\harmony\v1_09\apps\ path, create a folder as wsg.
4. In wsg folder, create an another folder and name it BM83_PIC32_code.
The source package is available in the BM83 MSPK v2.0 Release folder. The package is named BM83_PIC32_Code_yyyymmdd.zip. Please find the package under Software\Source Code.
5. Unzip the package, and rename BM83_PIC32_Code_yyyymmdd folder to BT_Speaker_Basic_Demo.
6. Copy BT_Speaker_Basic_Demo folder to \microchip\harmony\v1_09\apps\wsg\BM83_PIC32_code path.
A typical path to the project directory is: C:\microchip\harmony\v1_09\apps\wsg\BM83_PIC32_code\BT_Speaker_Basic_Demo\firmware

The source code is available in this path. Use Microchip MPLAB X IDE to open the projects in this path.

2. Installing and Using MHC

Perform the following steps to install the MHC plugin.

1. Open MPLAB X IDE.
2. Choose *Tools>Plugins*.
3. Select the Downloaded tab and click Add Plugins.
4. In the Add Plugins dialog, navigate to /utilities/mhc and choose MHC `com-microchip-mplab-modules-mhc.nbm` plug-in file, and click Open.

Figure 2-1. Add Plugins

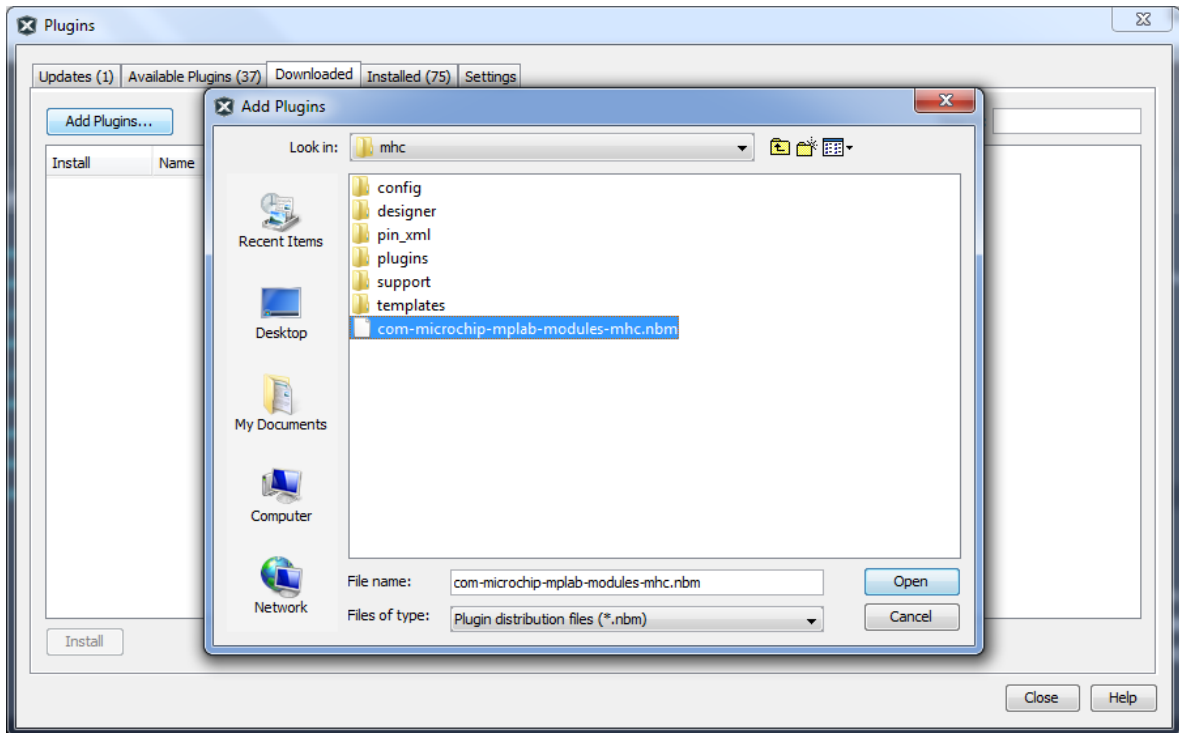

5. Ensure that the Install check box for the plug-in is selected and click Install.

Figure 2-2. MPLAB Harmony Configurator

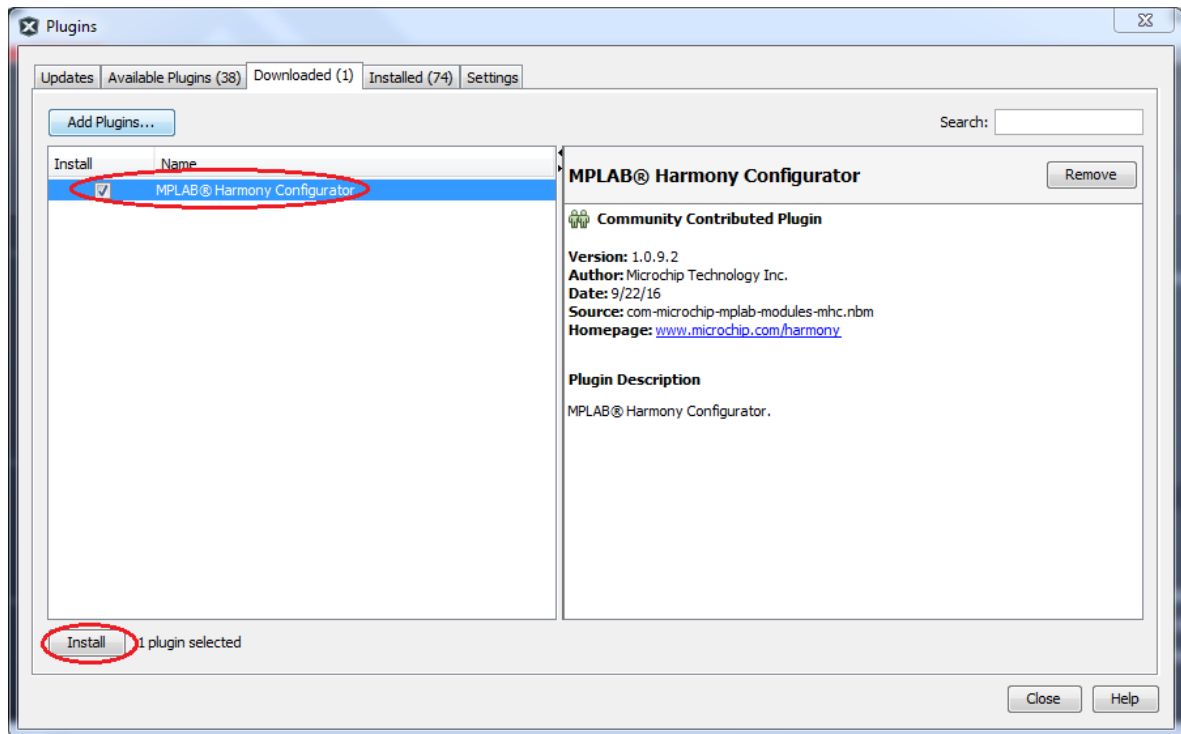

6. Follow the prompts from the installation and continue until the installation is complete.
7. Open MPLAB Harmony Configurator from *MPLAB X IDE>Tools>Embedded>MPLAB Harmony Configurator*.
8. In MPLAB Harmony configurator, open the configuration file available at `\BT Speaker Basic Demo\firmware\src\system_config\MX450_BASIC_DEMO0\MX450_BASIC_DEMO0.mhc`. This loads the hardware configuration used by the demo project into Harmony Configurator.
9. The USART configuration is available at *MPLAB Harmony & Application Configuration>Harmony Framework Configuration>Drivers>USART*. For USART, basic requirement is 115200 bps, and must be run as byte model. Following is a screenshot of USART configuration:

Figure 2-3. USART Configuration

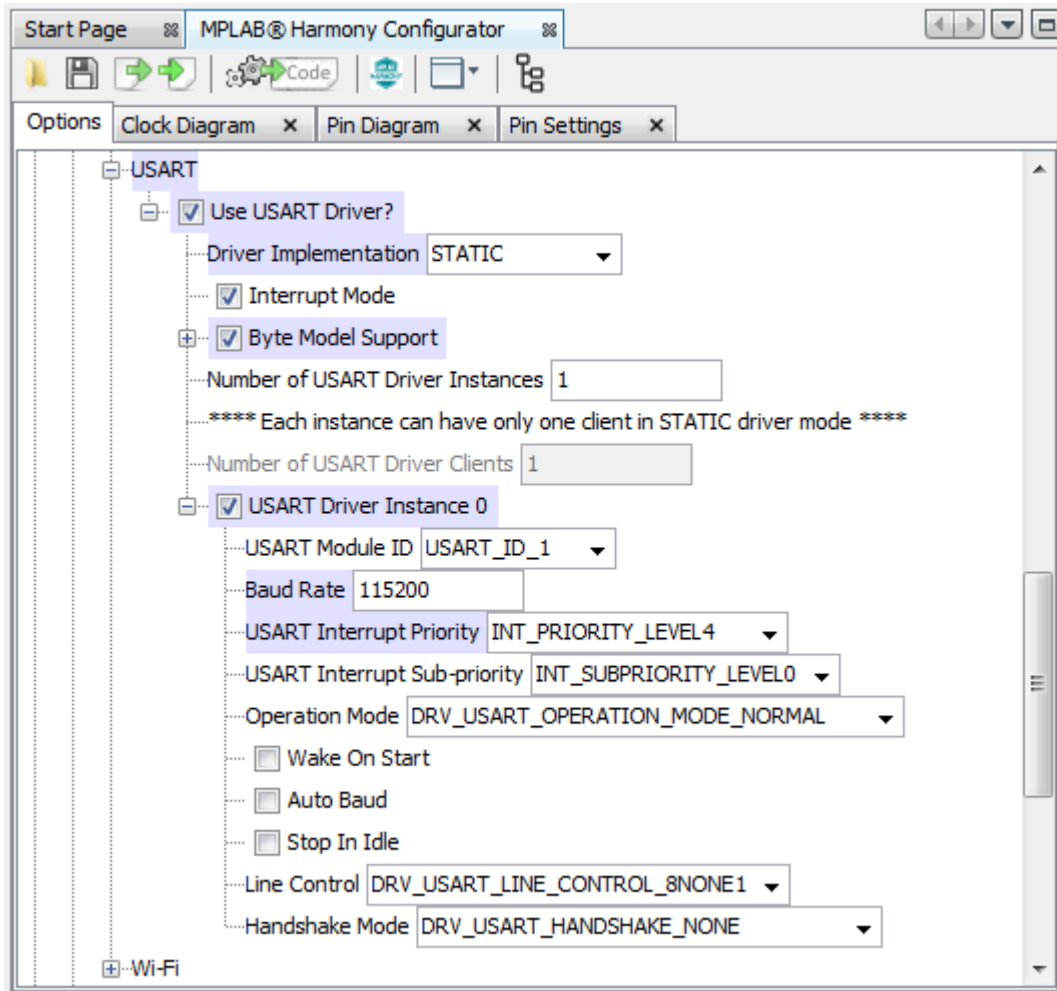

10. The I2C configuration is available at *MPLAB Harmony & Application Configuration > Harmony Framework Configuration > Drivers > I2C*. For I2C, basic requirement is 100kbps, and must use the Interrupt mode. Following is a screenshot of I2C configuration:

Figure 2-4. I2C Configuration

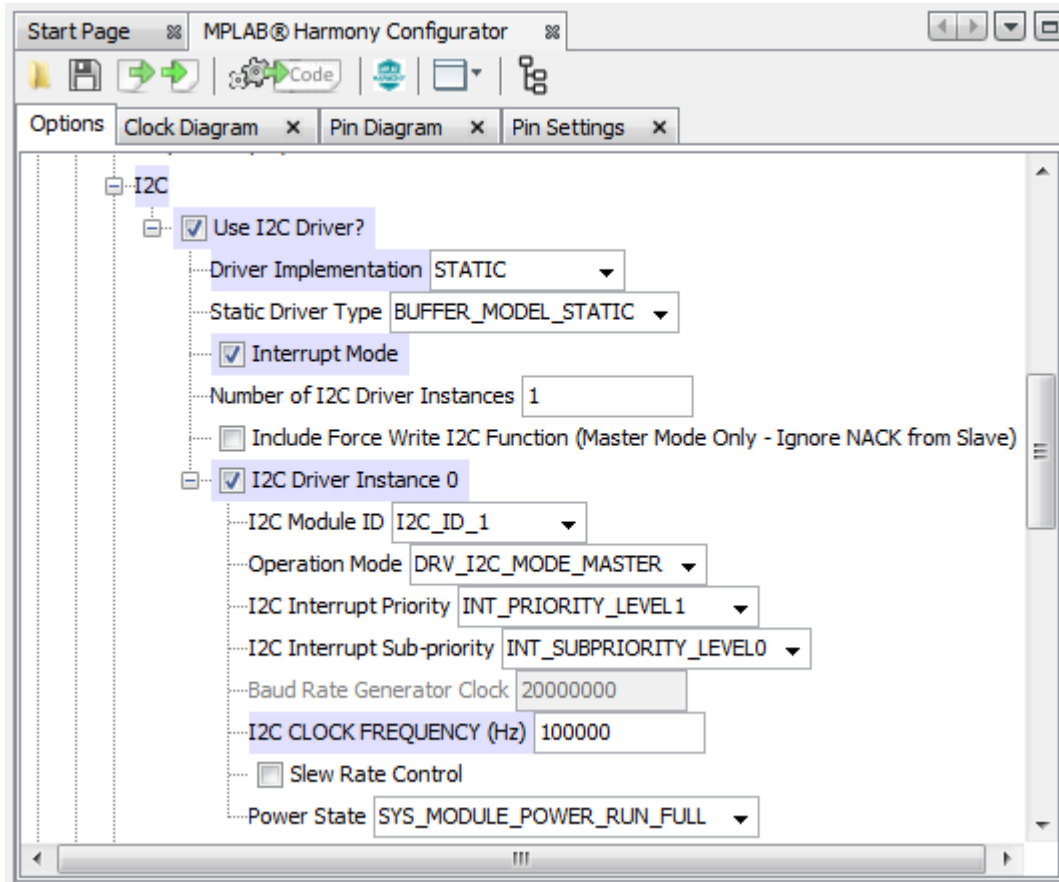

11. The Timer configuration is available at *MPLAB Harmony & Application Configuration>Harmony Framework Configuration>Drivers>Timer*. For timer, the source uses two timers.
 - 11.1. 1ms timer, which serves for major system usage
 - 11.2. 312.5 us timer, it is used for special purpose, and user can modify it for other purpose.

Following is a screenshot of timer configuration:

Figure 2-5. Timer Configuration

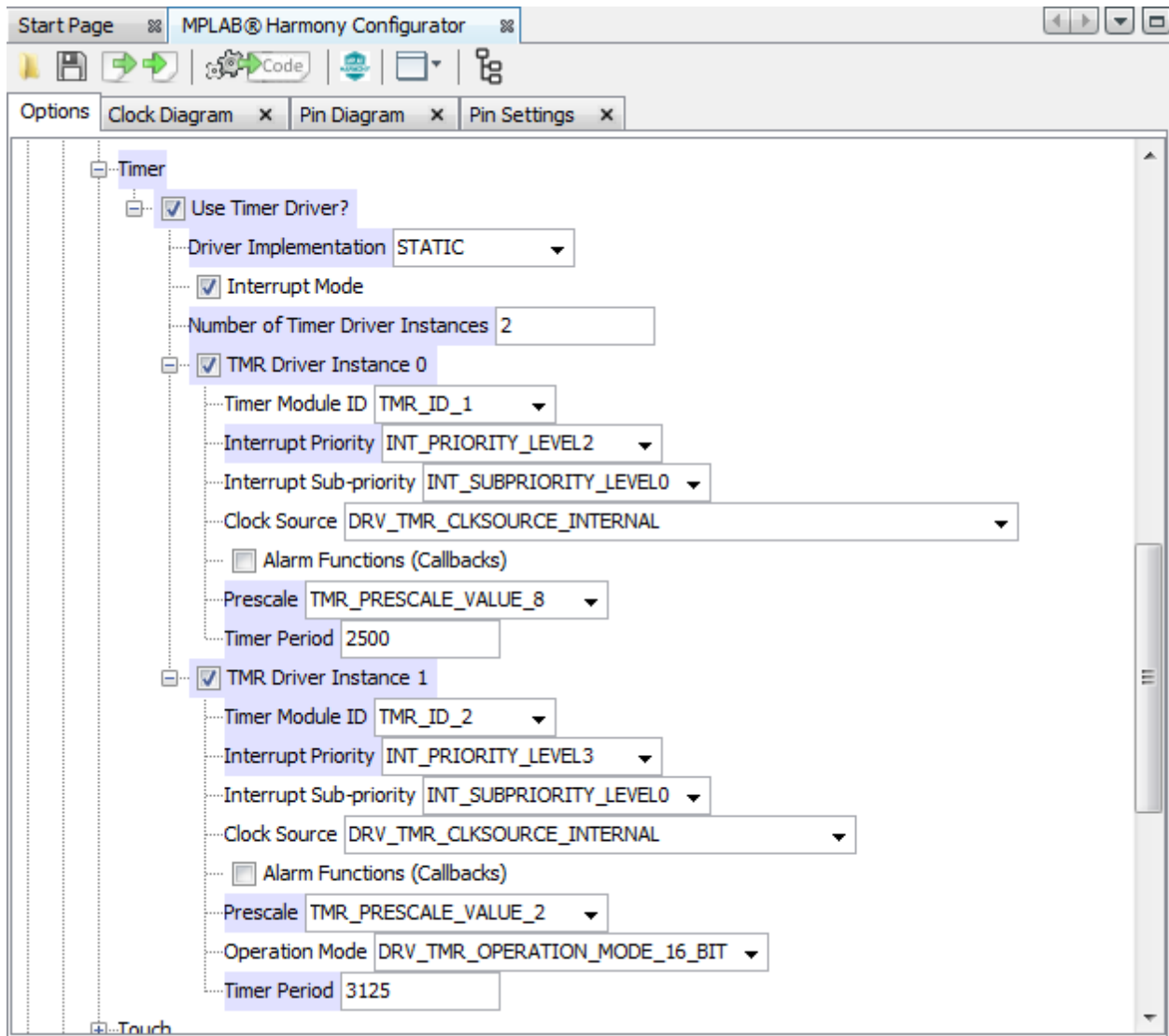

For more details, refer the documentation available at <https://www.microchip.com/mplab/mplab-harmony>.

Note: It is recommended to uninstall any other version of Harmony other than v1_09 in *Tools>Plugins>Installed*.

3. Hardware Requirements

- BM83 Audio Development Board (EVB)
- BM83 module mounted on BM83 carrier board
- Bluetooth-enabled smartphone:
 - Android™ device running Android version 4.3 or later
 - iOS iPhone® version 4S or later
- Windows host PC with USB port
- Speaker, microphone or headset
- Type-A to Micro-B USB cable
- STA369BW Audio Daughter Board (please refer to the *BM83 Bluetooth® Audio Development Board User's Guide for more information*)
- 15V DC power adapter
- MPLAB REAL ICE™/MPLAB ICD 3/PICkit™ 3

Note: For details on bringing the kit up and running the demo application, refer to the *BM83 Bluetooth® Audio Development Board User's Guide*.

4. Using Bluetooth Speaker Basic Demo Application

4.1 Source Code Architecture and Project Files

The following is the architecture of the of the host MCU code.

Figure 4-1. Architecture of the Host MCU Code

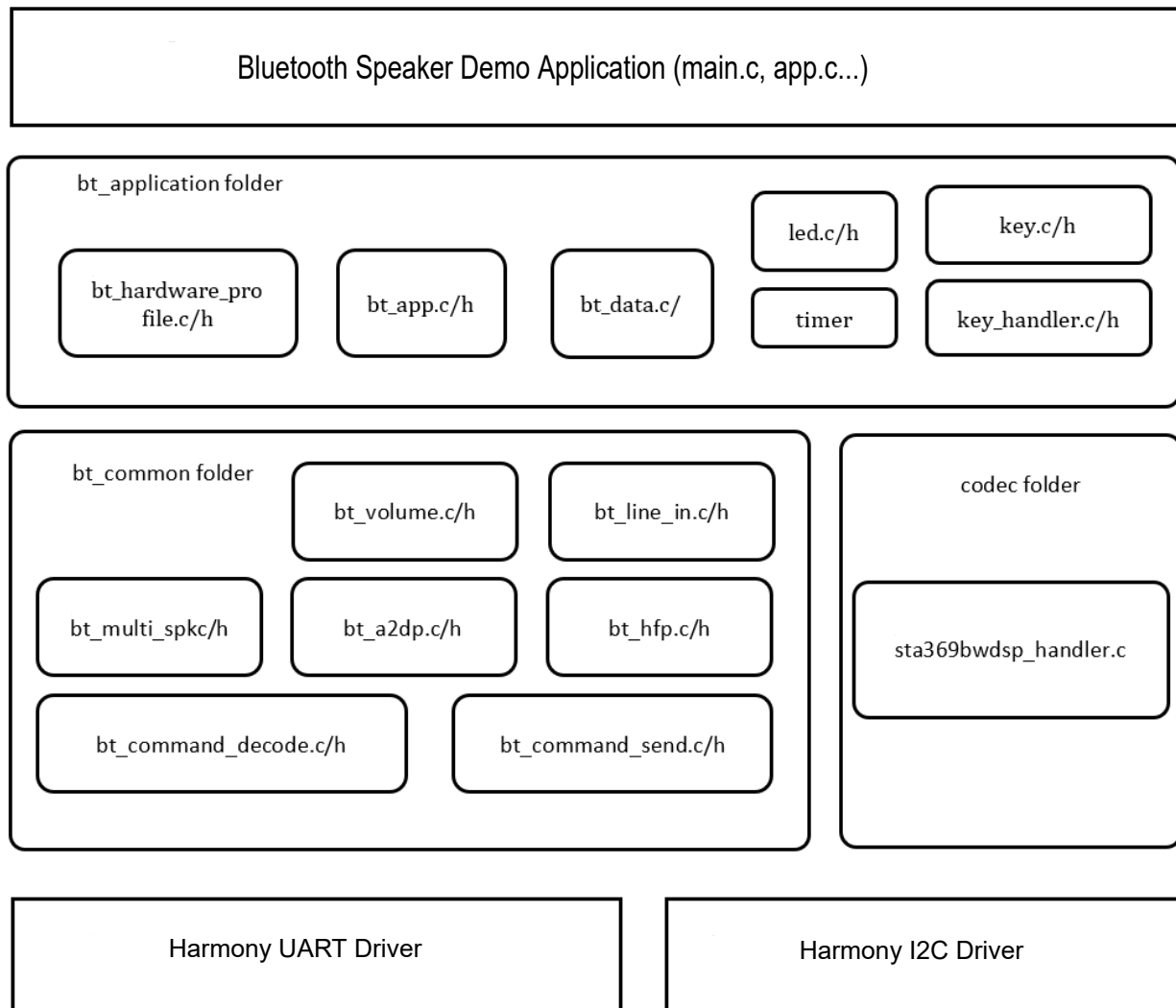

- **bt_application folder**

This folder contains the application files which control the basic demo application. To customize the application, the user may have to modify the files in this folder. For example, `bt_app.c` and `bt_app.h` files in this folder manage audio playback, power on, power off process, and its general event handlers. The `bt_data.c` and `bt_data.h` file manages BLE data and SPP/IAP profiles.

The `key.c`, `key_handler.c`, `led.c` control the behavior of keys and LEDs in the board. The user may need to update these files as per the application requirement. `bt_hardware_profile.c`, and `bt_hardware_profile.h` are used to define hardware interface.

Below is a brief introduction of files in the `bt_application` folder.

- `bt_app.c` and `bt_app.h`

These files contain code for audio playback, power on process, and power off process. It also contains generic events handlers and generic operations functions.

- `bt_data.c` and `bt_data.h`

These files contain data process functions, such as sending data, receiving data and put data to buffer, data events handlers, data process such as protocol with mobile APP, SPP/IAP profiles.

- `bt_hardware_profile.c` and `bt_hardware_profile.h`

These files contain macros which are used to define the hardware, resources, software features, and bridges to operate hardware.

- `key.c` and `key.h`

These files scan buttons GPIO, determine buttons is pressed, released, long pressed, double clicked and so on, and callback to `key_handlers.c` to process these buttons events.

- `key_handler.c` and `key_handler.h`

These files control the process for every button event, as a result, these files determine user interface of a demo.

- `led.c` and `led.h`

These files contain LED action service routine. Calls the routine to set LED action and style.

- `timer.c` and `timer.h`

These files contain a 1ms timer and a 312.5us timer.

- **bt common folder**

The source files in this folder are responsible for sending commands and receiving events from the BM83 device. The events are decoded and necessary actions are performed. Generally, the files in this folder are not expected to be modified by the user for customizing the application.

- `bt_a2dp.c` and `bt_a2dp.h`

These files contain event handlers and generic operation function for music control.

- `bt_command_decode.c` and `bt_command_decode.h`

These files contain UART receiving, UART event decoding, and dispatching these events to proper file module to handle.

- `bt_command_send.c` and `bt_command_send.h`

These files contain command sending APIs, and command sending task.

- `bt_hfp.c` and `bt_hfp.h`

These files contain events handlers and generic operations function for phone call control.

- `bt_line_in.c` and `bt_line_in.h`

These files contain events handlers for line-in, line-in detection task, and line-in entering and exit control.

- `bt_multi_spk.c` and `bt_multi_spk.h`

These files contain event handlers and generic operations function for multi-speaker control.

- `bt_volume.c` and `bt_volume.h`

These files contain volume event handlers, volume operation function, and volume synchronization with phone and with the group speakers.

- **Codec folder**

Source files in this folder are designed to support all codec chips. The current supported codec device is STA369BW.

- `sta369bwdsp_handler.c` and `sta369bwdsp_handler.h`

These files contain a basic control for STA369BW, an audio amplifier with DSP inside.

4.2 Host MCU Application Elements

The Host MCU application consists of five major elements:

1. Initialization routine
2. Main task
3. Timer service routine
4. Event handler
5. Operating functions

The `SYS_Initialize` function initializes all the Harmony modules and then initializes the application module function `APP_Initialize`. The `APP_Initialize` function resets the BM83 device and the initializes the state machine variable, LEDs, codec, Key button and other modules. The following figure shows the flow diagram of initialization routine.

Figure 4-2. Flow Diagram of Initialization Routine

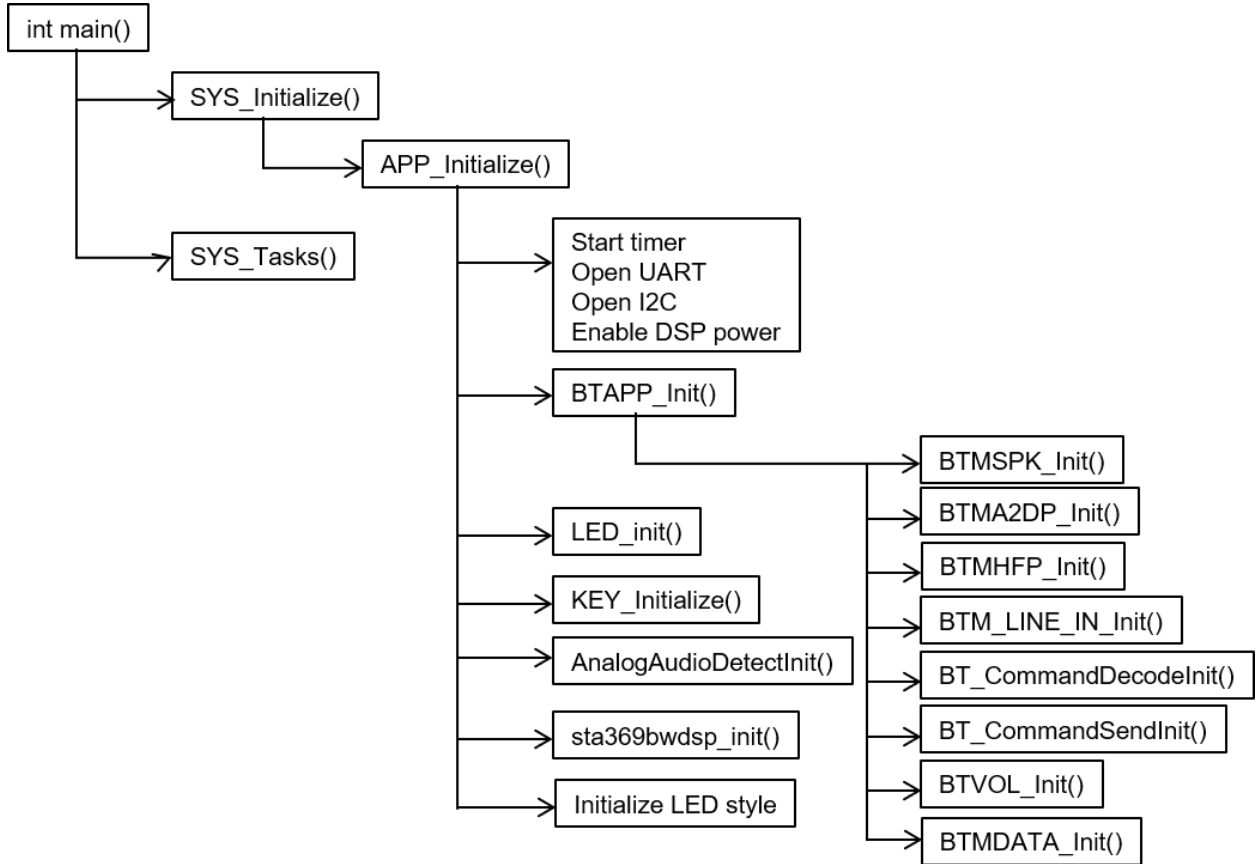

Once the initialization is complete, the `SYS_Task` function called by the Harmony driver is executed continuously in a while loop. This maintains the state machines polled by Harmony module and Application task function `APP_Task`. The timer service routine is used for providing timing control and used for implementing non-blocking delays.

Figure 4-3. Flow Diagram

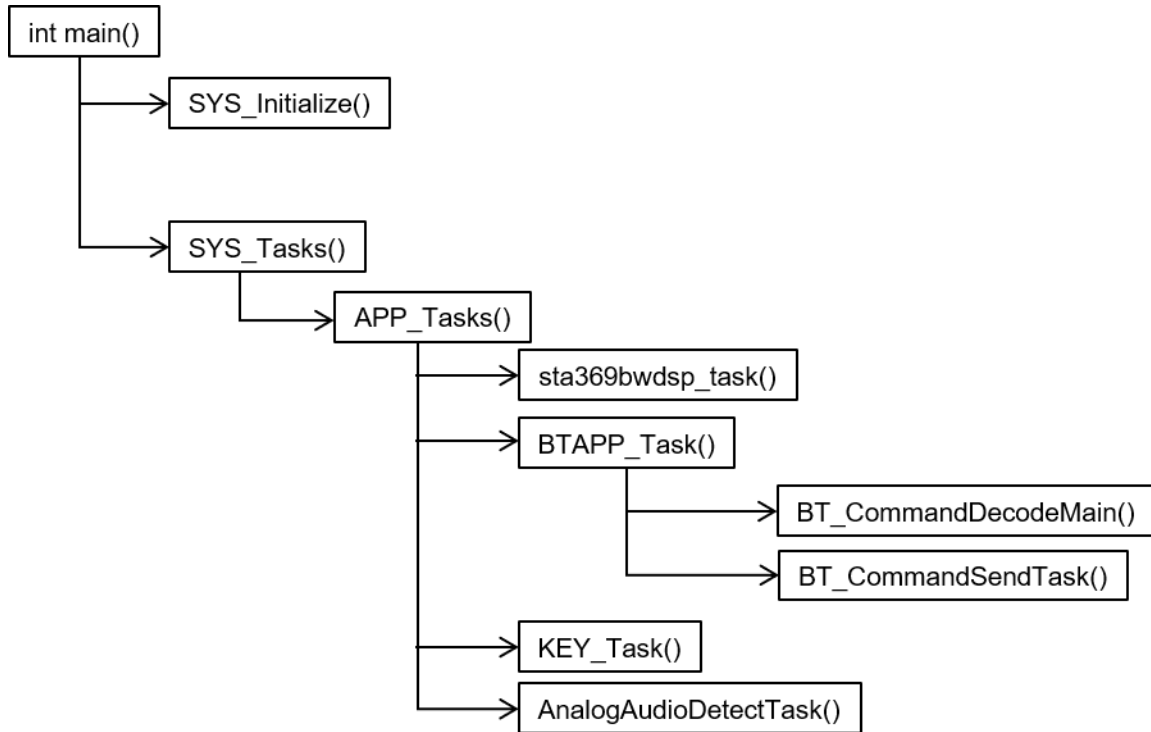

The following figure shows the state machine for the external codec controlled by host MCU.

Figure 4-4. State Machine for the External codec

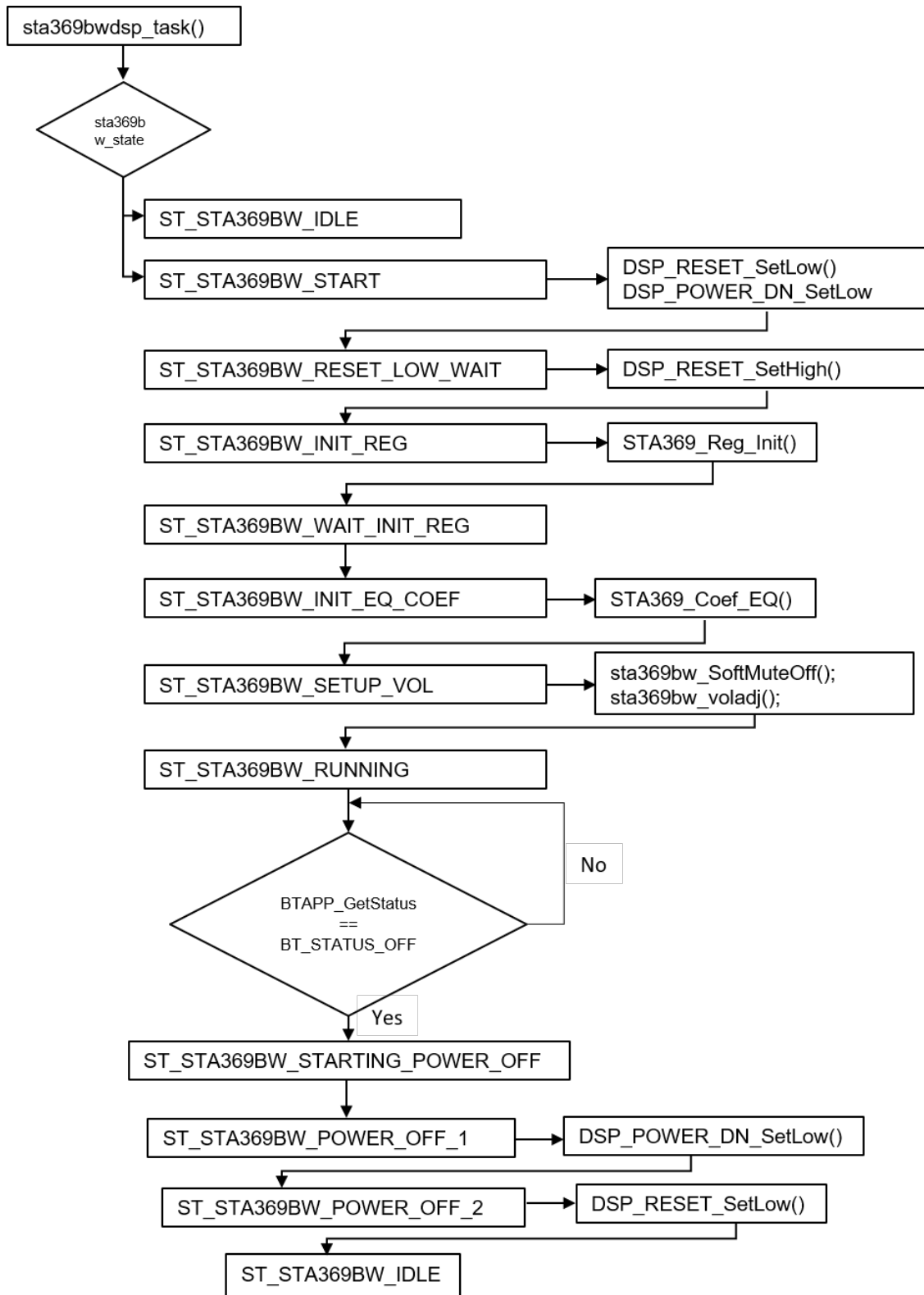

4.3 Event and Event Handler

Events are the data received from BM83 device through UART. The received UART data is decoded by `bt_command_decode` module, after it is decoded, it dispatches events to specific event handlers.

Figure 4-5. Event and Event Handler

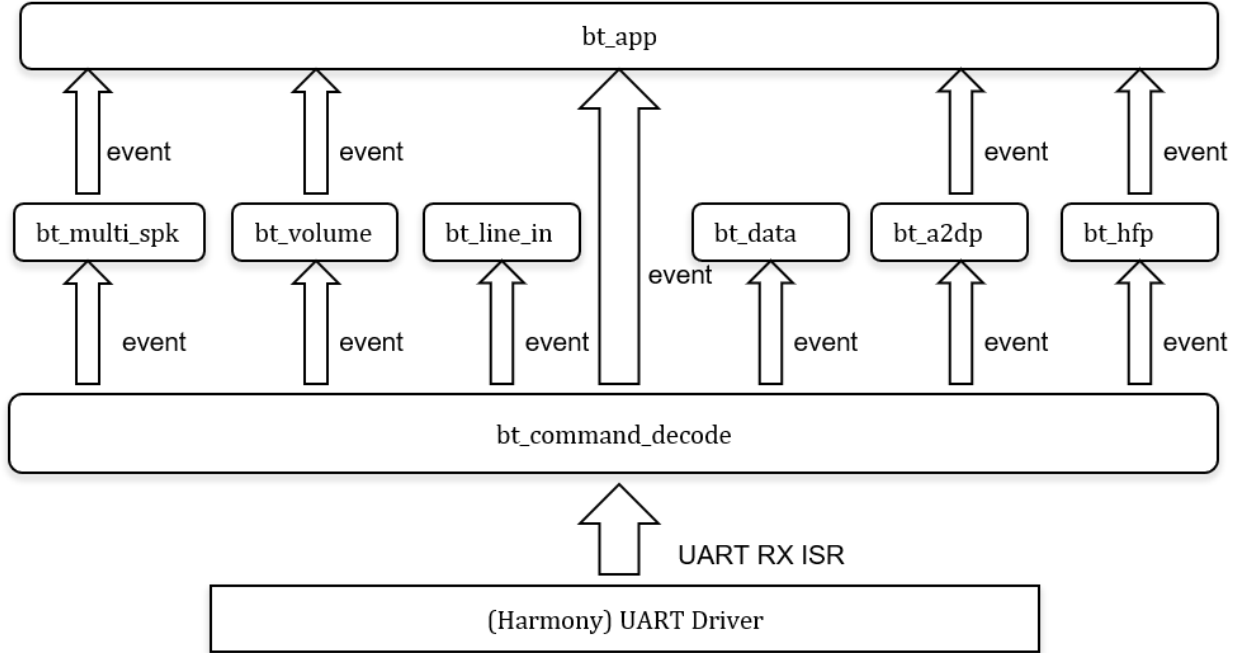

The `BT_CommandDecode()` function receives the UART data from the BM83 device through harmony UART driver. The `BT_CommandDecode` function calls the corresponding event handling function and passes it to the application event handler `BTAPP_EventHandler()` as shown in following figure.

Figure 4-6. Function Calls of BT_CommandDecode

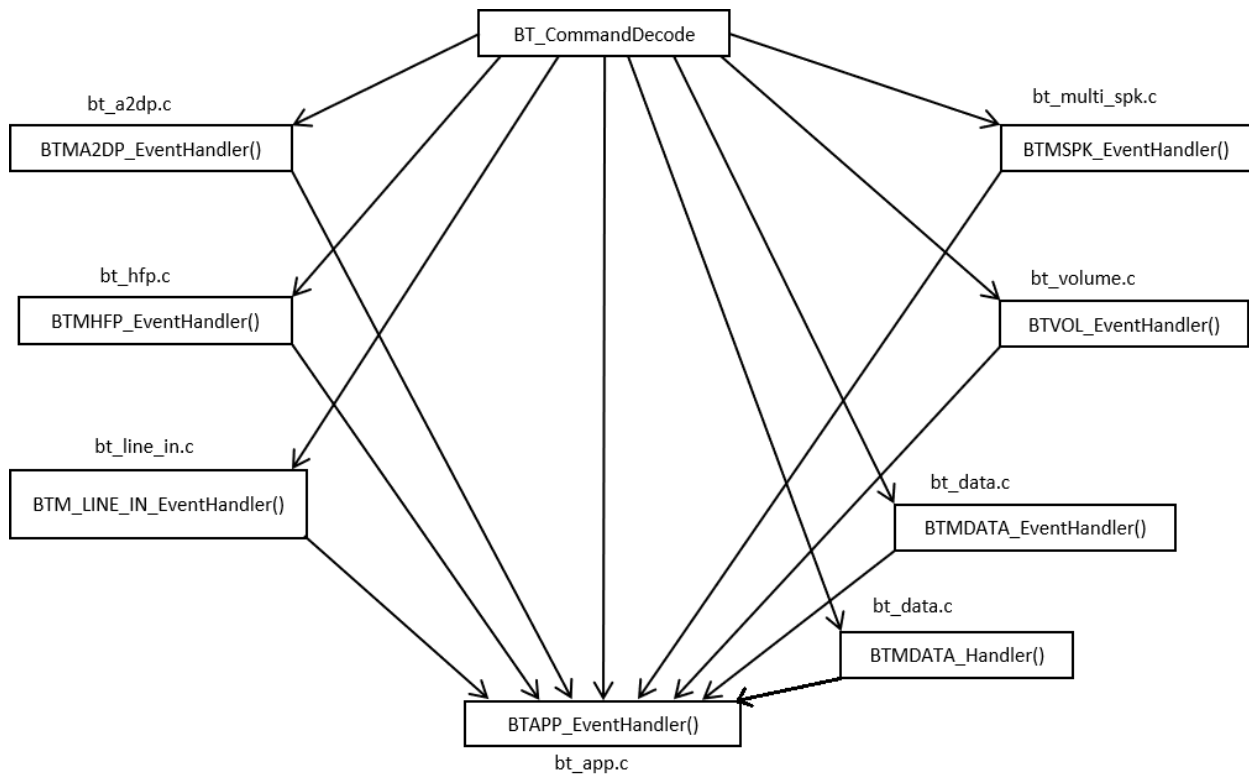

Events handled by BTMSPK_EventHandle():

- **BT_EVENT_NSPK_STATUS**
This event indicates the change in the Stereo mode or Concert mode status, it comes from 0x33 event (REPORT_nSPK_STATUS).
- **BT_EVENT_NSPK_AUDIO_CHANNEL**
This event indicates speaker under Stereo mode group has changed its audio channel setting, audio channel change means change between L+L, R+R, L+R(stereo), (L+R)/2(mixed).
- **NSPK_EVENT_ADD_SPEAKER3**
This event is not used with current Stereo mode technology. It was used for second slave to notify master to add third slave, as a result, master MCU sends command to master BM83 to add third speaker.

Events handled by BTVOL_EventHandler():

- **BT_EVENT_HFP_VOLUME_CHANGED**
This event indicates change in HFP volume. Value of this HFP volume is from 0 to 15.
- **BT_EVENT_AVRCP_VOLUME_CTRL**
This event indicates change in A2DP volume, but this volume shows the volume action that volume is either increased or decreased, and there is no value in it.
- **BT_EVENT_AVRCP_ABS_VOLUME_CHANGED**
This event indicates change in A2DP volume, there is volume value with this event, and value range is from 0 to 127.
- **NSPK_EVENT_SYNC_VOL_CTRL**
This event is used for volume synchronization between the Stereo mode or Concert mode group, the synchronization can be from master to slave, or from slave to master. It depends on BT firmware's ability. For this event, it is used for one speaker to notify other speaker in the same group to change its volume, this change indicates volume up or volume down action, the volume property can be either A2DP volume, HFP volume or even Line-In mode volume. After other speaker gets the volume up/down action, it needs to change its internal volume of either A2DP or HFP or Line-In mode.
- **NSPK_EVENT_SYNC_INTERNAL_GAIN**

This event is also used for volume synchronization in the Stereo or Concert mode group. Usually, this event only happens when slave is just connected. Then event contains A2DP volume and Line-In mode volume, and the volume value is from 0 to 15. Because the volume precision is low, therefore this source code does not use it. In this source code, when each slave is just connected, MCU of master speaker sends a customized volume by 0x2A command to that slave, and that slave modifies its internal volume.

- **NSPK_EVENT_SYNC_ABS_VOL**
This event is used for volume synchronization in the Stereo or Concert mode group, volume range is from 0 to 127. It is only affected in the A2DP mode.

Events handled by `BTMA2DP_EventHandler()`:

- **BT_EVENT_A2DP_CONNECTED**
This event means one A2DP link is established.
- **BT_EVENT_A2DP_DISCONNECTED**
This event means one A2DP link is disconnected.
- **BT_EVENT_AVRCP_CONNECTED**
This event means one AVRCP link is established.
- **BT_EVENT_AVRCP_DISCONNECTED**
This event means one AVRCP link is disconnected.
- **BT_EVENT_A2DP_STATUS**
This event indicates A2DP codec status (whether started playing music or stopped playing music) to the Host MCU.
- **BT_EVENT_PLAYBACK_STATUS_CHANGED**
This event means music playing status is changed.
- **BT_EVENT_SAMPLINGRATE_CHANGED**
This event means sampling rate is changed. This happens when music change, voice prompt or tone generating, call in and out.

Events handled by `BTMHFP_EventHandler()`:

- **BT_EVENT_HFP_CONNECTED**
This event means HFP link is established.
- **BT_EVENT_HFP_DISCONNECTED**
This event means HFP link is disconnected.
- **BT_EVENT_CALL_STATUS_CHANGED**
This event means change in calling status, which can happen when call is incoming, outgoing, dropping, and so on.

Events handled by `BTM_LINE_IN_EventHandler()`:

- **BT_EVENT_LINE_IN_STATUS**
This event means entering the Line-In mode or the Line-In mode exit.

Events handled by `BTAPP_EventHandler()`:

- **BT_EVENT_CMD_SENT_ACK_OK**
This event means one command is sent out successfully. This event is a software internal event, it is not sent from command decode, and is sent from command send module.
- **BT_EVENT_CMD_SENT_ACK_ERROR**
This event means one command is sent out but BM83 returns ACK with error. After capturing this event, application layer can decide if drop this command or retransmit it. If retransmits, does not require to do anything else (if drops this command) call `BT_GiveUpThisCommand()`. This event is a software internal event, it is not generated from command decode.
- **BT_EVENT_CMD_SENT_NO_ACK**
This event means one command is sent out but there is no ACK returned from BM83, which can be considered as one of ACK error, as a result, same with `BT_EVENT_CMD_SENT_ACK_ERROR` event, after captured this event, application layer can decide to give this command or retransmit it.
- **BT_EVENT_SYS_POWER_ON**
This event means BM83 is powered on.
- **BT_EVENT_SYS_POWER_OFF**

This event means BM83 is powered off.

- **BT_EVENT_SYS_STANDBY**
This event means BM83 enters standby mode. Standby means there is no profile linked.
- **BT_EVENT_SYS_PAIRING_START**
This event means BM83 enters the pairing mode.
- **BT_EVENT_SYS_PAIRING_OK**
This event means BM83 is paired successfully.
- **BT_EVENT_SYS_PAIRING_FAILED**
This event means pairing is failed.
- **BT_EVENT_LINKBACK_SUCCESS**
This event means device is linked back successfully.
- **BT_EVENT_LINKBACK_FAILED**
This event means link back process is failed.
- **BT_EVENT_HFP_LINK_CONNECTED**
This event is sent by `bt_hfp`, which shows application layer that HFP profile is established successfully, and application layer can do something, such as change the display or LED.
- **BT_EVENT_HFP_LINK_DISCONNECTED**
This event is sent by `bt_hfp`, which shows application layer that HFP profile is disconnected.
- **BT_EVENT_A2DP_LINK_CHANGED**
This event is sent by `bt_a2dp`, which shows application layer that A2DP profile is established, but `LINK_CHANGED` event usually happens when the first A2DP is established.
- **BT_EVENT_A2DP_LINK_CONNECTED**
This event is sent by `bt_a2dp`, which shows application layer that A2DP profile is established.
- **BT_EVENT_A2DP_LINK_DISCONNECTED**
This event is sent by `bt_a2dp`, which shows application layer that A2DP profile is disconnected.
- **BT_EVENT_SPP_LINK_CONNECTED**
This event is sent by `bt_data`, which shows application layer that SPP profile is established.
- **BT_EVENT_IAP_LINK_CONNECTED**
This event is sent by `bt_data`, which shows application layer that iAP is established.
- **BT_EVENT_SPP_IAP_LINK_DISCONNECTED**
This event is sent by `bt_data`, which shows application layer that SPP or iAP is disconnected.
- **BT_EVENT_MSPK_STANDBY**
This event is sent by `bt_multi_spk`, which shows application layer that either the Stereo mode or Concert mode group are canceled or disconnected.
- **BT_EVENT_MSPK_CONNECTING**
This event is sent by `bt_multi_spk`, which shows application layer that either the Stereo mode or the Concert mode group are connecting.
- **BT_EVENT_MSPK_CONNECTED_AS_NSPK_MASTER**
This event is sent by `bt_multi_spk`, which shows application layer that this speaker becomes a master speaker of a Stereo mode group.
- **BT_EVENT_MSPK_CONNECTED_AS_NSPK_SLAVE**
This event is sent by `bt_multi_spk`, which shows application layer that this speaker becomes a slave speaker of a Stereo mode group.
- **BT_EVENT_MSPK_CONNECTED_AS_BROADCAST_MASTER**
This event is sent by `bt_multi_spk`, which shows application layer that this speaker becomes a master speaker of a Concert mode group.
- **BT_EVENT_MSPK_CONNECTED_AS_BROADCAST_SLAVE**
This event is sent by `bt_multi_spk`, which shows application layer that this speaker becomes a slave speaker of a Concert mode group.
- **BT_EVENT_MSPK_BROADCAST_MASTER_CONNECTING_MORE**
This event comes from `bt_multi_spk`, which is to tell application layer that this speaker is a master speaker of a Concert mode group, and it continues to scan and connect to more slave speaker.
- **BT_EVENT_MSPK_BROADCAST_MASTER_CONNECTING_END**

This event is sent by `bt_multi_spk`, which shows application layer that Concert mode slave scanning is finished, because of time out or cancellation.

- **BT_EVENT_MSPK_SYNC_POWER_OFF**
This event is sent by command decode, it is used for power off synchronization in either a Stereo mode group or Concert mode group.
- **BT_EVENT_MSPK_SYNC_AUDIO_CHANNEL**
This event is sent by command decode and it is used for notifying that audio channel is changed, this event only happens with Stereo mode group.
- **BT_EVENT_NSPK_VENDOR_CMD**
This event carries customized data which transfer from master to slave. Therefore this event only happens with slave, it happens with both Stereo mode group and Concert mode group.
- **BT_EVENT_CLK_REPORTED**
This event carries Bluetooth clock, which is reported by BM83. This clock is used for doing some synchronized action for all speakers under a group.
- **BT_EVENT_READ_EEPROM_OK**
This event means specific EEPROM data reading is finished.

Events handled by `BTMDATA_EventHandler()`:

- **LE_STATUS_CHANGED**
This event means LE status is changed.
- **BT_EVENT_SPP_CONNECTED**
This event means SPP profile is connected successfully.
- **BT_EVENT_IAP_CONNECTED**
This event means iAP is connected successfully.
- **BT_EVENT_SPP_IAP_DISCONNECTED**
This event means SPP or iAP profile is disconnected.
- **BT_EVENT_SPP_IAP_REJECTED**
This is a special event. It means SPP or iAP is disconnected, but requires the MCU to send a command to BM83 to do an A2DP profile link back.

4.4 Sending Command and Command APIs

The host application can send commands to BM83 which in turn control BM83. The Key handler function detects button press and sends the corresponding command to `bt_command_send` as shown in the following figure.

Figure 4-7. Sending Command and Command APIs

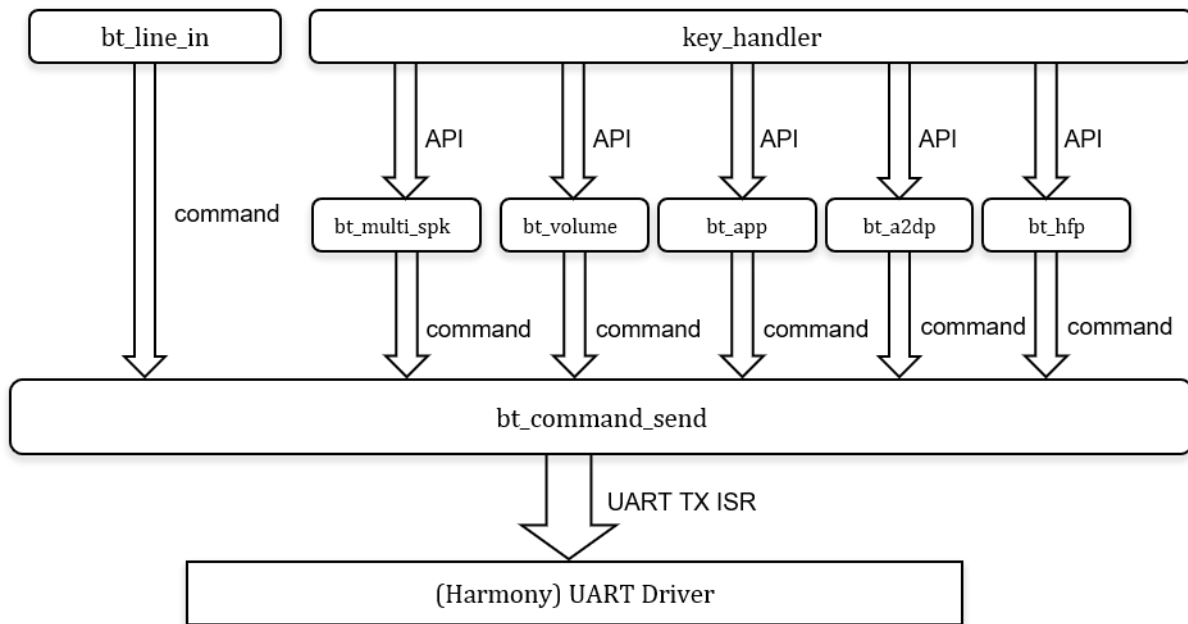

In `bt_command.c`, `void BT_CommandSendTask(void)` manages a state machine to control the command send process and most other subroutines are provided API for the user to send specific commands.

4.5 SPP/IAP/BLE Data Process

The data process including data receiving and data transfer, are in `bt_data.c` file. The following figure shows the relationship.

Figure 4-8. SPP/IAP/BLE Data Process

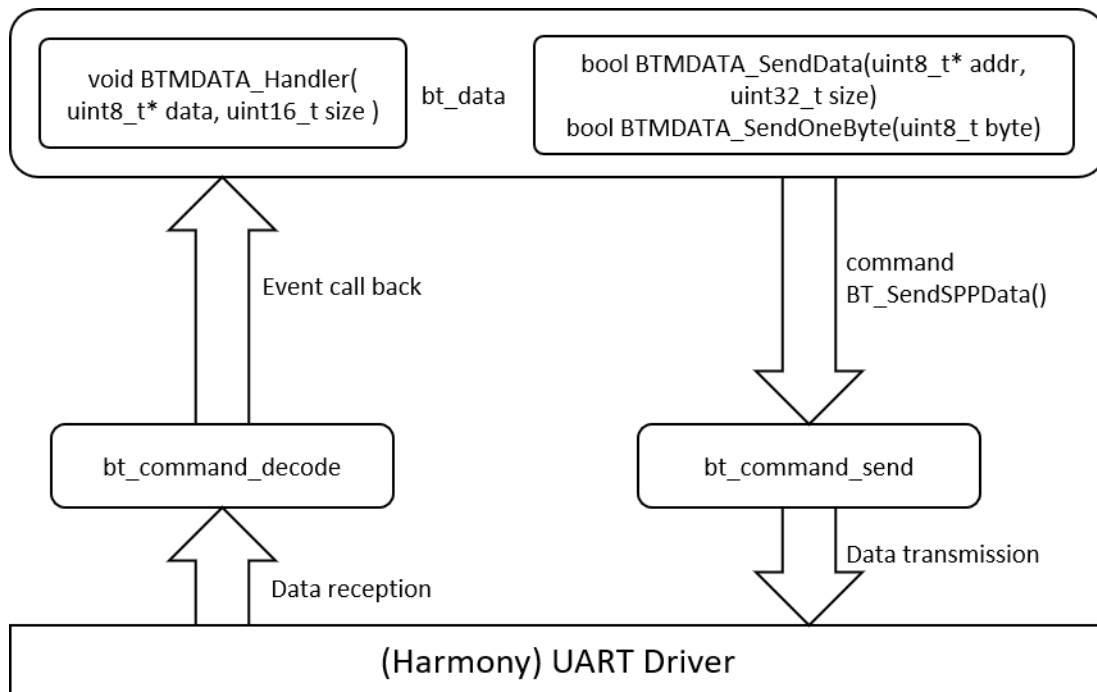

Received data goes to `BTMData_Handler()`. `dataPacketInfo` has the basic information to use the data, and then the user can add their own data process. `dataPacketInfo` is defined as follows:

```
typedef struct {
    DATA_PACKET_HEADER packetHeader;
    uint8_t packetType;
    uint16_t totalPayloadLength;
    uint16_t currentPayloadLength;
    uint8_t *currentPayloadData;
} DATA_PACKET_INFO;
```

The user can process the immediate data or use implemented service function to put the to FIFO and process them in other task. The following service functions are provided.

```
static bool BTMDATA_AddBytesToFIFO(uint8_t* data, uint8_t size)
static bool BTMDATA_ReadBytesFromFIFO(uint8_t* data, uint8_t size)
static bool BTMDATA_CheckFIFOBytesSize(uint8_t* data, uint8_t size)
```

These functions are designed to put data to FIFO, and read bytes from FIFO. Every different application has a different data process, therefore the user needs to implement their own data process.

For data transfer, use two implemented functions to send data.

```
bool BTMDATA_SendData(uint8_t* addr, uint32_t size)
bool BTMDATA_SendOneByte(uint8_t byte)
```

Other than these functions, there are several other functions for checking BLE/SPP/iAP status, and those are detailed in further sections.

4.6 Power On and Power Off Process

`void BTAPP_Task(void)` contains reset, power on and power off processes for BM83. It is a state machine task. The current `BTAPP_Task()` is a reference for these processes, but for the user, it does not have to be identical to the reference code, The actions during reset, power on and power off depends on actual application.

Typical process in `BTAPP_Task` is shown in the following figure:

Figure 4-9. BTAPP_Task Process

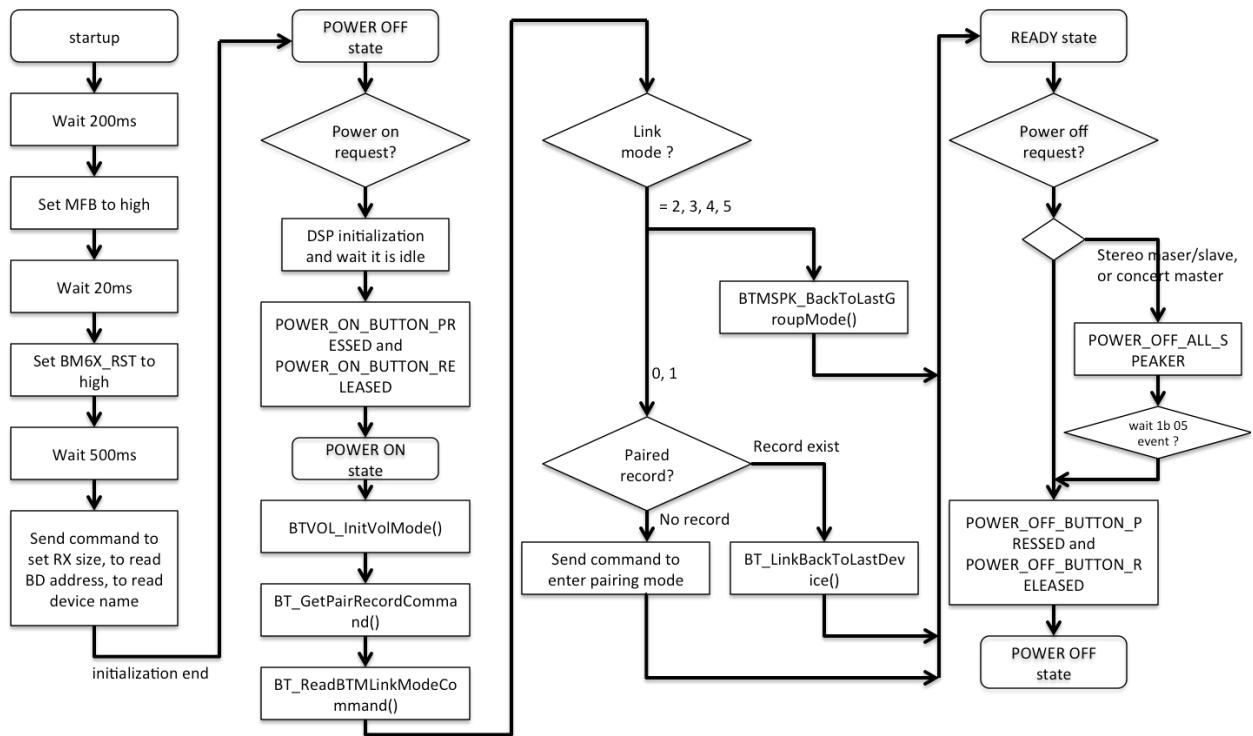

4.6.1 Reset process

For BM83 reset process, perform a hardware reset and get some basic information from BM83 by sending UART command.

Figure 4-10. Reset Process

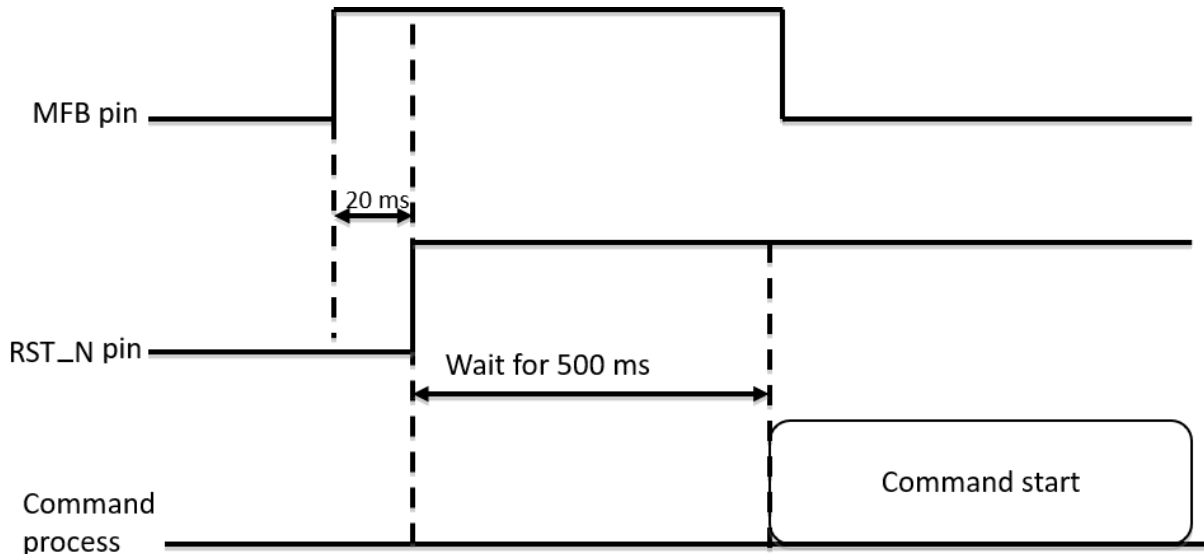

The hardware reset process includes the following steps:

- Set MFB pin to high.
- Wait for 20 ms, then set BM83 N_RST pin to high.
- Wait for 500 ms. During this 500ms, some of UART event will be received.

- Start sending the UART commands to set and get information.

After the hardware reset process, MCU starts to send commands to get the following information, as a typical application, it includes the following steps:

- Set RX buffer size.
- Read BM83 firmware version.
- Read BM83 UART protocol version.
- Read BM83 Bluetooth device address.
- Read BM83 Bluetooth device name.

Referring to the code, the following functions are complete when the state is `BT_STATE_INIT_COMMAND_START` and the code is copied:

```
BT_SetRXBufferSize();
BT_ReadFWVersion();
BT_ReadUARTVersion();
BT_ReadDeviceAddressCommand();
BT_ReadDeviceNameCommand();
BTAPP_TaskState = BT_STATE_POWER_OFF;
```

Change the state to `BT_STATE_POWER_OFF`, where the state waits for user to press button to power on the system.

4.6.2 Power-on Process

In the reference code, the power-on process includes the following steps:

- Initialize external DSP.
- Send `0x02 0x00 0x51` and `0x02 0x00 0x52` to set BM83 to power on.
- Synchronize MCU volume to BM83, and other necessity.
- Read paired record number.
- Send command to read link mode, or send command `0x02 0x00 0xF9` to let speaker go back to last role.
- If link mode is in the stereo mode master/slave or Concert mode master/slave, send `0x02 0x00 0xF9` to let speaker go back to last role. If link mode is in the single speaker mode or the multi-point mode, send command to link back, or send command to pair if no paired record is found.

This power-on process is for a typical multi-speaker application, but it need not be identical. The `0x02 0x00 0xF1` and `0x02 0x00 0x52` commands must be sent, others steps are optional and dependent on application.

After power on process is complete, the state is set to `BT_STATE_BT_RUNNING`.

4.6.3 Power-off Process

The power-off process is simple, which requires to send `0x02 0x00 0x53` and `0x02 0x00 0x54` command. However, when stereo mode or Concert mode group is created, the user must power off synchronization. As a result, when the speaker is in Stereo mode master, Stereo mode slave, Concert mode master, MCU sends `0x02 0x00 0xED` to notify all speakers to power-off. All speakers will receive an event `0x1B 0x05 0x00` (power-off synchronization), then every speaker starts a normal power-off process.

The general power-off process include the following steps:

- Send command `0x02 0x00 0x53`
- Send command `0x02 0x00 0x54`
- Set external DSP to power-off

If the current speaker is in Stereo mode master, Stereo mode slave, Concert mode master, it has the following steps:

- Send command `0x02 0x00 0xED` to notify all speaker to power-off
- Wait for event `0x1B 0x05 0x00`
- Send command `0x02 0x00 0x53`
- Send command `0x02 0x00 0x54`
- Set external DSP to power-off

After power-off process is complete, state is set to `BT_STATE_POWER_OFF`.

4.7 Buttons

BM83 EVB provides push buttons for the user's control of various audio functionalities. The function `KEY_Initialize()` is used to initialize the buttons during the application initialization. The `KEY_Task()` function reads the state of the button in every `KEY_TASK_PERIOD`. The `KEY_TASK()` function calls `KEY_Process()` to identify the mode of key press, that is, whether the user has pressed the button for short press or long press or double click. The `KEY_Process()` then calls `KEY_Handler()` function to perform the required action.

The following table summarizes the button names and the corresponding reference used in `KEY_Handler()` function.

Button Name	PCB Reference	SW Reference
PLAY/PAUSE	SW704	KEY_ID_PLAY_PAUSE
SEL	SW711	KEY_ID_PAIRING
PAIRING	SW703	KEY_ID_FUNC2
FWD	SW707	KEY_ID_FWD
REV	SW708	KEY_ID_REV
VOL_UP	SW702	KEY_ID_VOL_UP
VOL_DN	SW705	KEY_ID_VOL_DN

The following section describes the functionality of buttons used in the Bluetooth Speaker Basic Demo application.

- SEL button
 - Short press button
 - When speaker is in power off state, it initiates power on.
 - When speaker is in power on state, it initiates power off.
 - Long press
 - When speaker is in power off state, it initiates power on.
 - When speaker is in power on state, it initiates pairing.
 - Double click button
 - When speaker is in power off state, it initiates power on.
 - When speaker is in power on state, it responds with BT App version over UART.
 - Press and hold button for six seconds
 - Resets/clears the pairing information from the NVM memory.
- PLAY PAUSE button
 - When speaker is in power off state
 - Short or long press button powers on
 - When speaker is in power on state
 - Short press button
 - When call status is idle, it plays/pauses toggle function.
 - When it is in voice dialing, it cancels voice dial.
 - When call is incoming, it accepts the call.
 - When call is outgoing or active, it ends the call.
 - When a waiting call is incoming, it accepts the waiting call but will end the active call.
 - When one call is in hold state and another is active state, it switches the call between the active call and hold call.
 - Long press button
 - When call status is idle, it issues a voice dialing.
 - When it is in voice dialing, it cancels voice dial.

- When call is incoming, it rejects the call.
 - When call is outgoing, it ends the call.
 - When call is active, it switches voice between speaker and phone.
 - When a waiting call is incoming, it rejects the waiting incoming call.
 - When one call is in hold state and another is active, it ends the hold call but keeps the active call.
- Double click button
 - When call status is idle, it redials by the last number.
 - When call is outgoing, it ends the call.
- FWD button
 - Effective only when speaker is power on state.
 - Short press button plays next song.
 - Long press button starts FF play and cancels FF play when button is released.
- REV button
 - Effective only when speaker is in power on state.
 - Short press button plays previous song.
 - Long press button starts FR play and cancels FR play when button is released.
- VOL_UP button
 - Effective only when speaker is in power on state.
 - Long press creates the Concert mode group if there is no group, or cancels the group if group exists.
 - Double click the button to add more slave speaker when group exists in the Concert mode.
 - Single click increases volume
- VOL_DN button
 - Effective only when speaker is in power on state.
 - Long press creates the Stereo mode group if there is no group, or cancels the group if the group exists.
 - Double click switches the Stereo mode audio channel.
 - Single click decreases volume
- Pairing button
 - Effective only when speaker is in power on state.
 - Effective only when a Concert mode group is present.
 - Single click synchronizes the audio in the Concert mode group.

5. UART Communication Protocol

5.1 Connections Between BM83 and PIC 32 MCU

The following figure describes the hardware connection between BM83 and PIC32 MCU. It includes one UART channel and two GPIO channels.

Figure 5-1. UART Connection

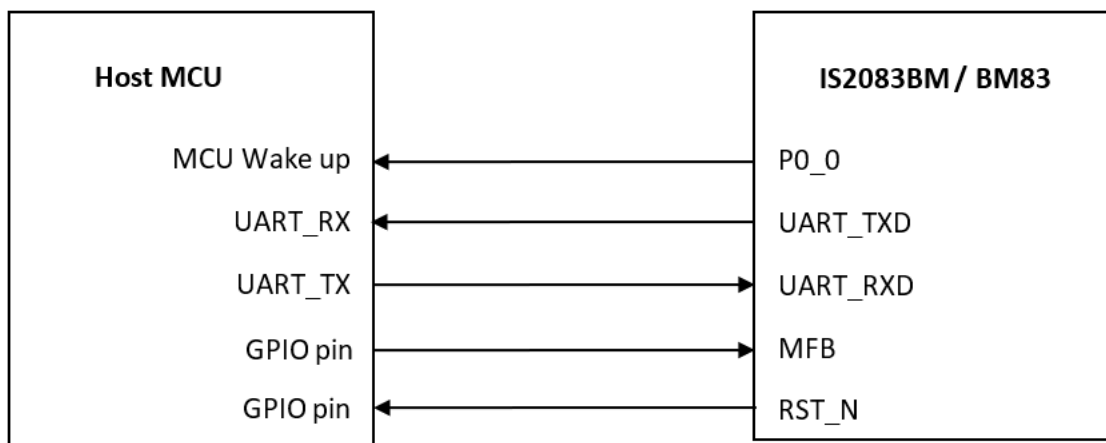

Table 5-1. UART Connection

Name	IO Direction for MCU	Description
UART_RXD	Output	UART Receive pin in BM83 Connect to UART_TX pin of Host MCU
UART_TXD	Input	UART Transmit pin in BM83 Connect to UART_RX pin of Host MCU
MFB	Output	<ol style="list-style-type: none"> Set to High to wake up BM83. Set to Low to make BM83 power save. During reset process, set MFB to High for about 500ms, then start command communication.
P0_0	Input	BM83 use P0_0 to wake up MCU.
RST_N	Output	Set low to make BM83 in Reset state, set high to release Reset state

BM83 supports baud rate from 2400 bps to 921600 bps with No Flow control. The default baud rate used is 115200. The baud rate can be changed using the Config GUI tool.

5.2 UART Command and Event Format

The UART command is the data sent from MCU to BM83, and the UART event is the data sent from BM83 to MCU. They are shown in the following figure:

Figure 5-2. UART Command and Event Format

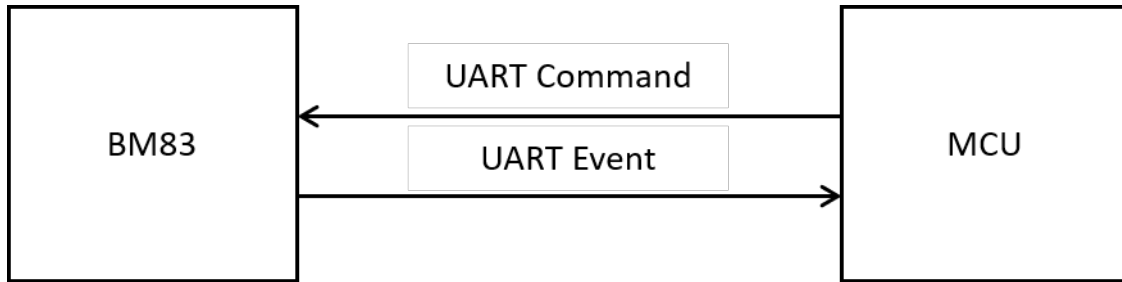

UART command and event have the same format.

5.3 UART Protocol

The UART protocol is used to communicate between BM83 and PIC32 MCU as shown the following figure.

Figure 5-3. UART Protocol

	HEAD		MID	DATA	CRC
	START	LENGTH	OP Code	PARAMETER	CHKSUM
BYTE NO	0	1 ~ 2	3	4 ~ XX	Length + 3
SIZE (BYTE)	1	2	1	0 ~	1
VALUE	0xAA	1 ~	Command/Event	Command/Event parameter	Check sum
	SINC WORD	Check sum to be calculated			TARGET LENGTH

Checksum is added to the complementary of summation of every byte after START WORD (LENGTH + OP Code + Parameter).

For example, the following table shows the data by MCU.

Table 5-2. UART Protocol Example

	START	LENGTH(H)	LENGTH(L)	OP CODE	PARAMETER	CHECKSUM
BYTE NO	0	1	2	3	4	5
VALUE	0xAA	0x00	0x02	0x14	0x33	0xB7

The checksum is 0xB7, which is calculated as follows:

$$CHKSUM = 1 + \sim(0x00 + 0x02 + 0x14 + 0x033)$$

Field Name	Size	Byte Offset	Description
Start of Packet	1	0	0xAA
Packet Length MSB	1	1	MSB of packet length, generally it is 0x00
Packet Length LSB	1	2	LSB of packet length. Length is the number of bytes counts from [Command/Event ID] to the end of [Payload Data]
Command/Event ID	1	3	Command or event ID.
Payload Data	N	4 ~ N+3	Command or event data payload

.....continued			
Field Name	Size	Byte Offset	Description
Checksum	1	N+4	Checksum of packet. To calculate checksum, get the sum from [Packet Length MSB] to the end of [Payload Data], then checksum = ~sum + 1.

5.4 UART Packet Process Rule

5.4.1 Command Packet Handling

For every command received from MCU, BM83 sends the ACK. If ACK is not received by MCU within the 200 ms timeout value, then MCU has to re-send the same command. After re-sending the command, if there is no ACK then MCU can reset the BM83.

Figure 5-4. For the Command Received from MCU, BM83 sends ACK

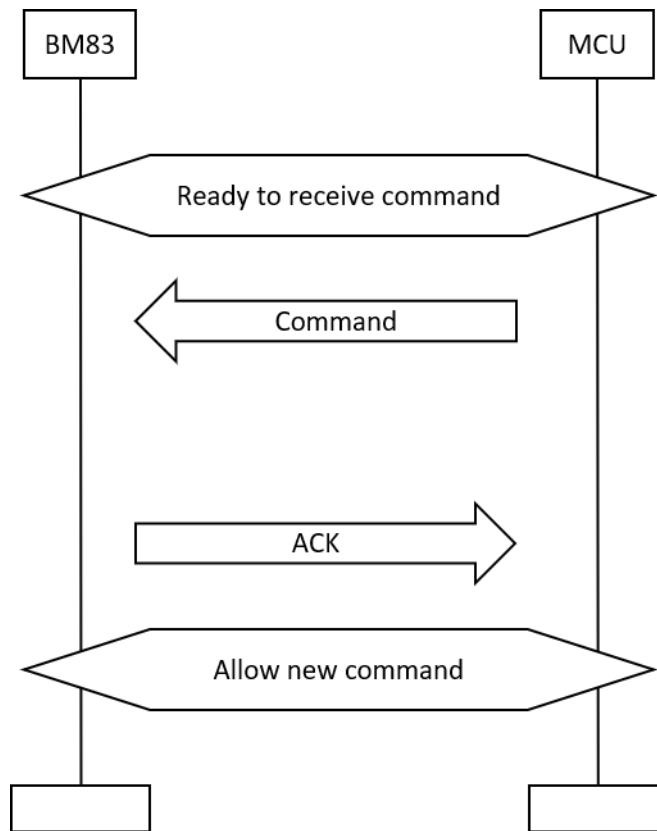
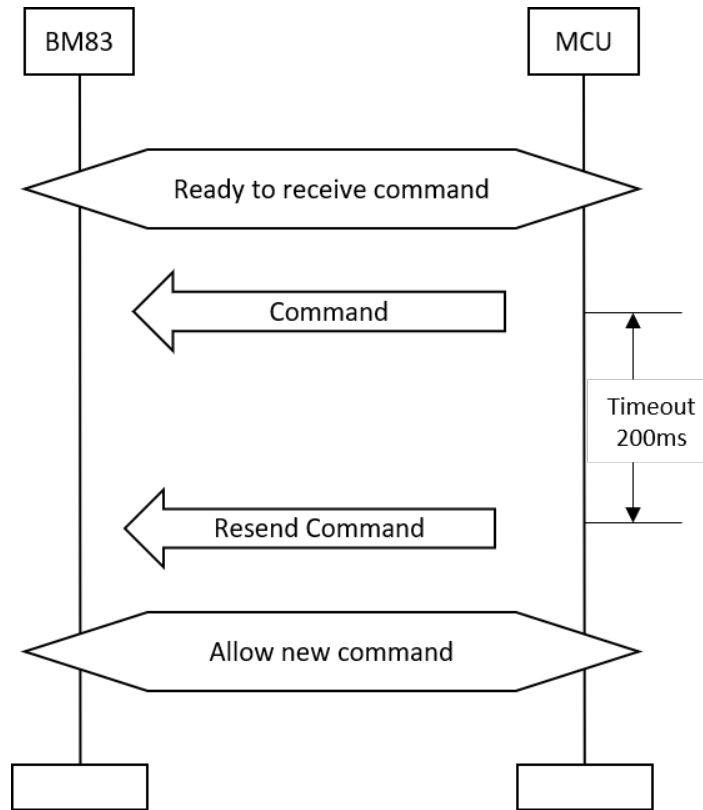

Figure 5-5. After Sending the Command MCU did not Receive ACK within 200ms, so MCU re-sends the Same Command



5.4.2 Event Packet Handling

After sending the event from BM83 to MCU, BM83 waits for 800 ms timeout period. If ACK is received from MCU within this time or timeout happens, then the next event is sent.

Figure 5-6. Event Packet Handling

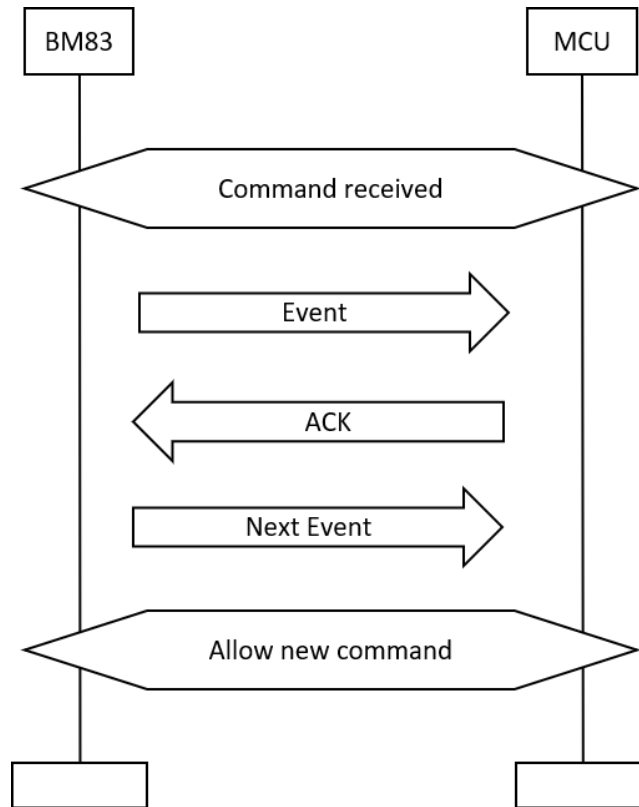

5.5 MFB Control

As shown in the following figure, before sending a UART command to BM83, set MFB pin to high for 2 to 3ms earlier than command starts sending. This requirement is to wake up BM83 using the MFB pin, in case it is in the Power Save mode, because BM83 may lose UART commands in the Power Save mode.

Figure 5-7. MFB Control

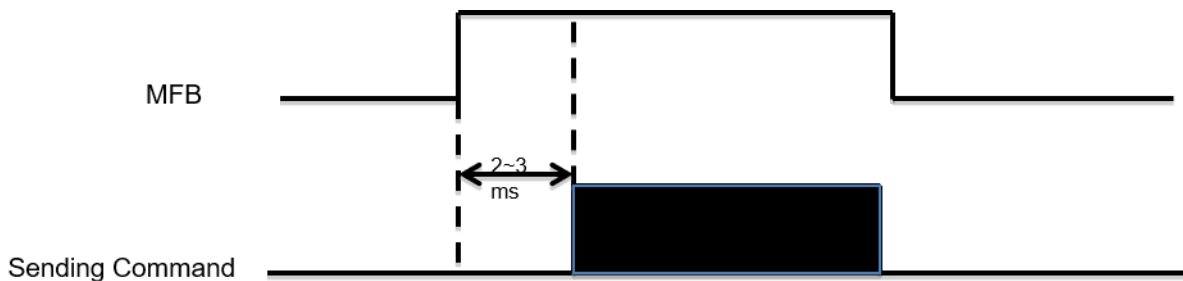

5.6 UART Commands

The following table lists the UART commands.

Table 5-3. UART Command

OP Code	Command	Return Event
0x00	Make_Call	Call_Status

.....continued		
OP Code	Command	Return Event
0x01	Make_Extension_Call	
0x02	MMI_Action	
0x03	Event_Mask_Setting	
0x04	Music_Control	
0x05	Change_Device_Name	
0x06	Change_PIN_Code	
0x07	BTM_Parameter_Setting	
0x08	Read_BTM_Version	Read_BTM_Version_Reply
0x0A	Vendor_AT_Command	Report_Vendor_AT_Event
0x0B	AVC_Vendor_Dependent_Cmd	AVC_Vendor_Dependent_Response
0x0C	AVC_Group_Navigation	
0x0D	Read_Link_Status	Read_Link_Status_Reply
0x0E	Read_Paired_Device_Record	Read_Paired_Device_Record_Reply
0x0F	Read_Local_BD_Address	Read_Local_BD_Address_Reply
0x10	Read_Local_Device_Name	Read_Local_Device_Name_Reply
0x12	Send_SPP/iAP_Data	
0x13	BTM_Utility_Function	
0x14	Event_ACK	
0x15	Additional_Profiles_Link_Setup	
0x16	Read_Linked_Device_Information	Read_Linked_Device_Information_Reply
0x17	Profiles_Link_Back	
0x18	Disconnect	
0x19	MCU status indication	
0x1A	User_Confirm_SPP_Req_Reply	
0x1B	Set_HF_Gain_Level	
0x1C	EQ_Mode_Setting	EQ_Mode_Indication
0x1D	DSP_NR_CTRL	
0x1E	GPIO_Control	Report_Input_Signal_Level
0x1F	MCU_UART_Rx_Buffer_Size	
0x20	Voice_Prompt_Cmd	Report_Voice_Prompt_Status
0x23	Set_Overall_Gain	

.....continued

OP Code	Command	Return Event
0x24	Read_BTM_Setting	REPORT_TYPE_BTM_SETTING
0x25	Read_BTM_Batt_CHG_Status	BTM_Battery_Status BTM_Charging_Status
0x26	MCU_Update_Cmd	
0x27	REPORT_BATTERY_CAPACITY	
0x28	LE_ANCS_Service_Cmd	
0x29	LE_Signaling_Cmd	
0x2A	nSPK Vendor Cmd	
0x2B	Read_nSPK_Link_Status	Report_nSPK_Link_Status
0x2C	NSPK_Sync_Audio_Effect	
0x2D	LE_GATT_CMD	
0x2F	LE_App_CMD	
0x30	DSP_RUNTIME_PROGRAM	
0x31	Read_Vendor_EEPROM_Data	Report_Vendor_EEPROM_Data
0x32	Query IC version information	Report_IC_Ver_Info
0x33	Voice_Prompt_Ind_Cmd	
0x34	Read_BTM_Link_Mode	Report_BTM_Link_Mode
0x35	Configure_Vendor_Parameter	
0x37	nSPK Exchange_Link_Info_Cmd	
0x38	UART_CMD_NSPK_SET_GIAC	
0x39	READ_FEATURE_LIST	Report_Read_Feature_List_Reply
0x3A	Personal_MSPK_GROUP_Control	
0x3B	UART_CMD_TEST_DEVICE	
0x3F	PBAPC_Cmd	PBAPC_Event
0x41	AVRCP_Browsing_Cmd	AVRCP_Browsing_Event

5.6.1 Make_Call (0x00)

Command	Op Code	Command Parameters	Return Event
Make_Call	0x00	Data_Base_Index, Phone_Number	Call_Status

Description:

This command is used to trigger HF action for making an outgoing call. Send out a standard AT command intended for placing a call to a phone number. Only voice calls are covered in this specification.

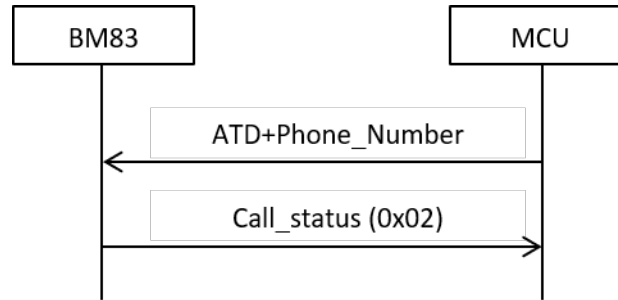

Precondition:

HF should be in connected state.

Command Parameters:

Data_Base_Index: Length: 1 Byte

Value	Parameter Description
0x00	Database 0 for dedicate link
0x01	Database 1 for dedicate link

Phone_Number: Length: 19 Bytes

Value	Parameter Description
0XXXXX	ASCII code of the phone number. The maximum length of phone number is 19.

Return error: Length: 1 Byte

Value	Description	Condition
0x01	Command disallow	No HF connection exists
0x03	Parameter error	No phone number

5.6.2 Make_Extension_Call (0x01)

Command	Op Code	Command Parameters	Return Event
Make_Extension_Call	0x01	Data_Base_Index, Extension_Number	

Description:

This command is used to trigger HF action for making an extension call number. During an ongoing call, the HF transmits the AT+VTS command to instruct the AG to transmit a specific DTMF code to its network connection.

Precondition:

1. An ongoing Service Level Connection between the AG and the HF shall exist.
2. An ongoing call in the AG exists.

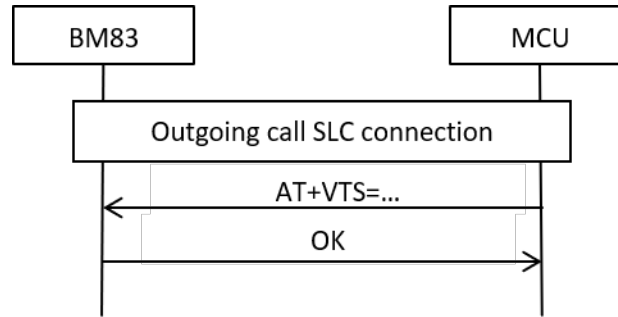

Command Parameters:

Data_Base_Index: Length: 1 Byte

Value	Parameter Description
0x00	Database 0 for dedicate link
0x01	Database 1 for dedicate link

Extension_Number: Length: 10 Bytes

Value	Parameter Description
0xXXXX	ASCII code of the Extension phone number. The maximum length of phone number is 10 bytes

Return Parameters:

Status: Length: 1 Byte

Value	Parameter Description
0x00	Command succeeded
0x01 – 0xFF	Command failed. See listing of Error Codes.

Return error: Length: 1 Byte

Value	Description	Condition
0x01	Command disallow	No HF connection exists

5.6.3 Event_Filter_Setting (0x03)

Command	Op Code	Command Parameters	Return Event
Event_Filter_Setting	0x03	Event_Filter	

Description:

This command is used to control events that are to be filtered for the Host MCU. If the bit in the Event_Filter_Setting is set to one, then the event associated with that bit is not reported. The Host MCU must deal with each event that is generated by BTM. The event filter setting allows the Host MCU to control events that interrupt it. The default values of Event Filter Bit are all zero.

Precondition:

None.

Command Parameters:

Event_Filter: Length: 4 Bytes

Value	Parameter Description
0XXXXXXXX	Refer the Event_Filter_Table Bit is 0:BTM will report this event Bit is 1:BTM will not report this event

Event_Filter_Table: Length: 4 Bytes

Byte 0	Parameter Description
Bit 0	Reserved
Bit 1	Reserved
Bit 2	Call status
Bit 3	Incoming call number or caller ID
Bit 4	SMS received
Bit 5	Missed call
Bit 6	Max cell phone battery level
Bit 7	Current cell phone battery level

Byte 1	Parameter Description
Bit 0	Cell Phone Roaming
Bit 1	Max Cell Phone Signal Strength
Bit 2	Current Cell Phone Signal Strength
Bit 3	Cell Phone Service Status
Bit 4	BTM Battery Level
Bit 5	BTM Charging Status
Bit 6	BTM Reset To Default Settings OK
Bit 7	BTM DAC Gain Level

Byte 2	Parameter Description
Bit 0	EQ Mode
Bit 1	Remote Device Friendly Name
Bit 2	AVC Vendor Specific Response
Bit 3	Unknown AT Command Result Code
Bit 4	Page Status
Bit 5	Ringtone Status

.....continued	
Byte 2	Parameter Description
Bit 6	Reserved
Bit 7	Reserved
Byte 3	Parameter Description
Bit 0	Reserved
Bit 1	Reserved
Bit 2	Reserved
Bit 3	Reserved
Bit 4	Reserved
Bit 5	Reserved
Bit 6	Reserved
Bit 7	Reserved

5.6.4 Music_Control (0x04)

Command	Op Code	Command Parameters	Return Event
Music_Control	0x04	Reserved, Action	

Description:

This command is used to trigger AVRCP commands for music control.

Precondition:

AVRCP should be active. If not, BTM will initiate the AVRCP connection if A2DP is active and no voice call in progress.

Command Parameters:

Reserved: Length: 1 Byte

Value	Parameter Description
0xXX	Reserved

Action: Length: 1 Byte

Value	Parameter Description
0x00	Stop fast forward or rewind
0x01	Fast forward
0x02	Fast forward with repeat, Send fast forward command for every 812.5ms
0x03	Rewind
0x04	Rewind with repeat, send rewind command for every 812.5ms

.....continued	
Value	Parameter Description
0x05	Play command
0x06	Pause command
0x07	Play pause toggle
0x08	Stop command
0x09	Next song
0x0A	Previous song

Return error: Length: 1 Byte

Value	Description	Condition
0x01	Command disallow	No AVRCP connection exist
0x03	Parameter error	Incorrect action value

5.6.5 Change_Device_Name (0x05)

Command	Op Code	Command Parameters	Return Event
Change_Device_Name	0x05	BT_Device_Name	

Description:

This command is used to change the device name of BTM.

Note: This command does not update the device name in the E2PROM. Therefore, new name set by this command will not be effective after the power cycle.

Precondition:

None.

Command Parameters:

BT_Device_Name: Length: 32 Bytes

Value	Parameter Description
0xFFFF	Bluetooth device name

5.6.6 Change_PIN_Code (0x06)

Command	Op Code	Command Parameters	Return Event
Change_PIN_Code	0x06	PIN Code	

Description:

This command is used to change the BT PIN code of BTM. Host MCU shall assert this command before BTM into Pairing mode.

Precondition:

None

Command Parameters:

PIN Code: Length: 4 Octets

Value	Parameter Description
0xXXXX	4 digit number by ASCII format

5.6.7 BTM_Parameter_Setting (0x07)

Command	Op Code	Command Parameters	Return Event
BTM_Parameter_Setting	0x07	Parameter, Value1, Value2...	

Description:

This command is used to set the specific parameters that are listed in the below table of BTM.

Precondition:

None

Command Parameters:

Parameter: Length: 1 Byte

Value	Parameter Description
0x00	To set pairing timeout value
0x01	To set supported codec type (This change will update the E2PROM)
0x02	To enable/disable BTM Standby mode (This change will update the E2PROM)
0x03	To set the recharging battery capacity threshold
0x04	To set supported profile
0x05	Set SBC bitpool setting: this must be set before A2DP connection is established
0x06	Setting iAP2 serial number (This change will update the E2PROM)
Others	Reserved

Default the settings does not update to EEPROM.

Value1 for Parameter 0x00: Length: 1 Byte

Value	Parameter Description
0x00	Pairing timeout disabled
0xXX	Pairing timeout value in the unit of 30.08secs.

Value1 for Parameter 0x01: Length: 1 Byte

Value	Parameter Description
Bit 1	Bit Mask:
Bit 2	Should be set to 1 for enabling AAC
	Should be set to 1 for enabling vendor specific codec
	By default SBC codec is enabled

Value1 for Parameter 0x02: Length: 1 Byte

Value	Parameter Description
0x00	To disable BTM Standby mode
0x01	To enable BTM Standby mode

Value1 for Parameter 0x03: Length: 1 Byte

Value	Parameter Description
0xXX	Range in 0~100 and Unit In Percentage

Value1 for Parameter 0x04: Length: 1 Byte

Value	Parameter Description (Bit Mask: Set to 1 to enable)
Bit 0	HSP
Bit 1	HFP
Bit 2	A2DP
Bit 3	AVRCP CT
Bit 4	AVRCP TG
Bit 5	SPP
Bit 6	iAP
Bit 7	Reserved

Value1 for Parameter 0x05: Length: 1 Byte

Value	Parameter Description
0xXX	Maximal bitpool setting Range : 0~250

Value2 for Parameter 0x05: Length: 1 Byte

Value	Parameter Description
0xXX	Minimal bitpool setting Range : 0~250

Value1 for Parameter 0x06: Length: 1 Byte

Value	Parameter Description
0xXX	iAP2 serial number length Max. length: 16

Value2-N for Parameter 0x06: Length: (N-2) Bytes

Value	Parameter Description
xxxx	iAP2 serial number (ASCII string)

Return error: Length: 1 Byte

Value	Description	Condition
0x03	Parameter error	Incorrect parameter value Parameter 0x03: check battery setting range Parameter 0x05: check bit-pool range

5.6.8 Read_BT_M_Version (0x08)

Command	Op Code	Command Parameters	Return Event
Read_BT_M_Version	0x08	Type	Read_BT_M_Version_Reply

Description:

This command is used to query the supported UART command set version or FW version of BTM.

Precondition:

None.

Command Parameters:

Type: Length: 1 Byte

Value	Parameter Description
0x00	To query supported UART command set version
0x01	To query BTM FW version
0x02	To query EEPROM version
0x03~0xFF	Reserved

5.6.9 Vendor_AT_Cmd (0x0A)

Command	Op Code	Command Parameters	Return Event
Vendor_AT_Cmd	0x0A	Data_Base_Index, Cmd_Payload	Report_Vendor_AT_Event

Description:

This command is used to send any vendor specific AT command.

Precondition:

HF should be in connected state and there should not be any vendor specific AT command already in progress.

Command Parameters:

Data_Base_Index: Length: 1 Byte

Value	Parameter Description
0x00	Database 0 for dedicate link

.....continued	
Value	Parameter Description
0x01	Database 1 for dedicate link

Cmd_Payload: Length: N Bytes

Value	Parameter Description
0xXXXX..	The AT command ASCII string excluding the "AT". For example : If MCU want to send "AT+ABCDE", the command payload should be "+ABCDE"

Return error: Length: 1 Byte

Value	Description	Condition
0x01	Command disallow	<ol style="list-style-type: none"> 1. No HF connection exists 2. Vendor specific AT command in progress

5.6.10 AVC_Vendor_Dependent_Cmd (0x0B)

Command	Op Code	Command Parameters	Return Event
AVC_Vendor_Dependent_Cmd	0x0B	Data_Base_Index, Avc_Cmd_Payload	AVC_Vendor_Dependent_Response

Description:

This command is used to send vendor dependent AVC type commands. Only single packet type is supported for this command. Refer the Avc_Cmd_Payload table for the supported PDU IDs. For more details on settings, refer to the AVRCP Specification.

Precondition:

AVRCP should be active.

Command Parameters:

Data_Base_Index: Length: 1 Byte

Value	Parameter Description
0x00	Database 0 for dedicate link
0x01	Database 1 for dedicate link

Avc_Cmd_Payload: Length: N Bytes

Value	Parameter Description
Byte 0	AVRCP1.3 AVC vendor dependent command PDU ID
0x10	Get capabilities
0x11	List player application setting attributes
0x12	List player application setting values
0x13	Get current player application setting value
0x14	Set player application setting value
0x15	Get player application setting attribute text
0x16	Get player application setting value text
0x17	Inform displayable character set
0x18	Inform battery status of CT
0x20	Get element attributes
0x30	Get play status
0x31	Register notification
0x40	Request continuing response
0x41	Abort continuing response
Byte 1	0x00
Byte 2-3	Parameter length
Byte 4-N	Parameter

Return error: Length: 1 Byte

Value	Description	Condition
0x01	Command disallow	No AVRCP connection

5.6.11 AVC_Group_Navigation (0x0C)

Command	Op Code	Command Parameters	Return Event
AVC_Group_Navigation	0x0C	Data_Base_Index, Navigation_Type	

Description:

The basic group navigation commands have a similar behavior as the Forward and Backward commands, but instead of navigating to the next/previous song they are used to navigate to the first song in the next/previous group. For more details on settings, refer to the AVRCP Specification.

Precondition:

AVRCP should be active.

Command Parameters:

Data_Base_Index: Length: 1 Byte

Value	Parameter Description
0x00	database 0 for dedicate link

.....continued	
Value	Parameter Description
0x01	database 1 for dedicate link

Navigation_Type: Length: N Bytes

Value	Parameter Description
0x00	Next group This function is used to move to the first song in the next group.
0x01	Previous group This function is used to move to the first song in the previous group.

Return error: Length: 1 Byte

Value	Description	Condition
0x01	Command disallow	No AVRCP connection

5.6.12 Read_Link_Status (0x0D)

Command	Op Code	Command Parameters	Return Event
Read_Link_Status	0x0D	Reserved	Read_Link_Status_Reply

Description:

This command is used to query the device state, profile link status, playback status and streaming status. Refer to the Read_Link_Status_Reply event for the detailed information.

Precondition:

None.

Command Parameters:

Reserved: Length: 1 Byte

Value	Parameter Description
0xXX	Reserved

5.6.13 Read_Paired_Device_Record (0x0E)

Command	Op Code	Command Parameters	Return Event
Read_Paired_Device_Record	0x0E	Reserved	Read_Paired_Device_Record_Reply

Description:

This command is used to read the paired device information from BTM. The information will have link priority. 1 is the highest (newest device) and 4 is the lowest (oldest device) and BD address of the paired devices.

Precondition:

None.

Command Parameters:

Reserved: Length: 1 Byte

Value	Parameter Description
0xXX	Reserved

5.6.14 Read_Local_BD_Address (0x0F)

Command	Op Code	Command Parameters	Return Event
Read_Local_BD_Address	0x0F	Reserved	Read_Local_BD_Address_Reply

Description:

This command is used to read the local BD address.

Precondition:

None.

Command Parameters:

Reserved: Length: 1 Byte

Value	Parameter Description
0xXX	Reserved

5.6.15 Read_Local_Device_Name (0x10)

Command	Op Code	Command Parameters	Return Event
Read_Local_Device_Name	0x10	Reserved	Read_Local_Device_Name_Reply

Description:

This command is used to read the local device name.

Precondition:

None.

Command Parameters:

Reserved: Length: 1 Byte

Value	Parameter Description
0xXX	Reserved

5.6.16 Send_SPP/iAP_Or_LE_Data (0x12)

Command	Op Code	Command Parameters	Return Event
Send_SPP/iAP_Or_LE_Data	0x12	Channel_Index, Type, Total_Length, Payload_Length, Payload	

Description:

This command is used to send the SPP/iAP or LE data to remote BT devices.

Precondition:

- SPP should be in connected state or
- LE transparent service should be active

Command Parameters:

Channel_Index: Length: 1 Byte

Value	Parameter Description
0xXX	<p>MCU receives channel index information while SPP connection is established. If the connection is iAP or iAP2, MCU receives the correct channel index when Report_iAP_Info is received because iAP session is created until that time.</p> <p>bit0 to 1: bluetooth connection index (data base index). Ranges from 0 to 3.</p> <p>bit 2: LE connection indicator</p> <p>bit 3 to 5: rfcomm index. Ranges from 0 to 7.</p> <p>bit 6 to 7: iAP session index. 1 is first session and 2 is second session. 0 means not a iAP / iAP2 connection</p>

Type: Length: 1 Byte

Value	Parameter Description
0x00	Single packet
0x01	Fragmented start packet
0x02	Fragmented continue packet
0x03	Fragmented end packet

Total_Length: Length: 2 Bytes

Value	Parameter Description
0xFFFF	Total payload length

Payload_Length: Length: 2 Bytes

Value	Parameter Description
0xFFFF	Payload length in this packet

Payload: Length: N Bytes

Value	Parameter Description
0xFFFF	The payload in this packet

Return error: Length: 1 Byte

Value	Description	Condition
0x01	Command disallow	<ol style="list-style-type: none"> No SPP connection BLE transparent service disable
0x03	Parameter error	Incorrect parameter
0x04	BTM busy	BTM is busy
0x05	BTM memory full	TX buffer is full

5.6.17 BTM_Utility_Function (0x13)

Command	Op Code	Command Parameters	Return Event
BTM_Utility_Function	0x13	Utility_Function_Type,Parameter	

Description:

This command is used to indicate BTM to execute the specific utility function. Supported functions are listed in the following table.

Precondition:

None.

Command Parameters:

Utility_Function_Type: Length: 1 Byte

Value	Parameter Description
0x00	Host MCU ask BTM to process NFC detected function.
0x01	To Enable/Disable in-built Aux Line In function If in-built Aux Line In Function is enabled then once Line In is detected, BTM will process built-in aux line-in detection procedure
0x02	To generate the specific tone
0x03	To make BTM inactive or active
0x04	To indicate charger adapter status
0x05 ⁽¹⁾	To indicate BTM that remote device supports TTS engine. The BTM shall disable internal TTS engine.
0x06	To update partial EEPROM data which are related to part of audio configuration.
0x07	Voice prompt for the given version number.
0x08	For NSPK, MCU notifies the BTM current power condition
0x09	To update vendor EEPROM data
0x0A	For NSPK, To inform master that certain status is changed in slave side
0x0B	To read serial number. For this command, MCU receives event Report_Vendor_EEPROM_Data with report data 16 bytes.
0x0C ⁽¹⁾	To switch audio channel
0x0D ⁽¹⁾	Customized MCU report: MCU report specified information by the following parameter.
0x0E ⁽¹⁾	Customized MCU request: MCU request specified information by the following parameter. BTM replies the specified information by E3E

Note:

1. Default customize commands are disabled. Refer the firmware release note to identify the customize commands support.

Parameter for Utility_Function_Type 0x00: Length: 1 Byte

Value	Parameter Description
0xXX	Reserved

Function Description:

This function is used for MCU to ask BTM to process “NFC detected” function.

If BTM is under OFF state, BTM powers on.

If BTM is under PAIRING state, BTM enters STANDBY state.

If BTM is under other state, BTM enters PAGE SCAN ENABLE state.

Parameter for Utility_Function_Type 0x01: Length: 1 Byte

Value	Parameter Description
0x00	Line in is not controlled by MCU
0x01	Line in is controlled by MCU

Parameter for Utility_Function_Type 0x02: Length: 1 Byte

Value	Parameter Description
0xXX	Tone type

Tone Type: Length: 1 Byte

Value	Parameter Description	Sub-Parameter
0x00	N/A	0
0x01	200Hz	100msec
0x02	500Hz	100msec
0x03	1KHz	100msec
0x04	1.5KHz	100msec
0x05	2KHz	100msec
0x06	200Hz	500msec
0x07	500Hz	500msec
0x08	1KHz	500msec
0x09	1.5KHz	500msec
0x0A	2KHz	500msec
0x0B	200Hz / mute / 200Hz	100msec for each tone
0x0C	500Hz / mute /500Hz	100msec for each tone
0x0D	1KHz / mute /1KHz	100msec for each tone
0x0E	1.5KHz / mute /1.5KHz	100msec for each tone
0x0F	2KHz / mute / 2KHz	100msec for each tone

.....continued

Value	Parameter Description	Sub-Parameter
0x10	200Hz / mute /200Hz / mute /200Hz	100msec for each tone
0x11	500Hz / mute /500Hz / mute /500Hz	100msec for each tone
0x12	1KHz / mute /1KHz / mute /1KHz	100msec for each tone
0x13	1.5KHz / mute /1.5KHz / mute /1.5KHz	100msec for each tone
0x14	2KHz / mute /2KHz / mute /2KHz	100msec for each tone
0x15	200Hz / mute /200Hz / mute /200Hz mute // 200Hz	100msec for each tone
0x16	500Hz / mute /500Hz / mute /500Hz / mute /500Hz	100msec for each tone
0x17	1KHz / mute /1KHz / mute /1KHz / mute /1KHz	100msec for each tone
0x18	1.5KHz / mute /1.5KHz / mute /1.5KHz / mute /1.5KHz	100msec for each tone
0x19	2KHz / mute /2KHz / mute /2KHz / mute /2KHz	100msec for each tone
0x1A	500Hz / 400Hz / 300Hz / 200Hz	50msec for each tone
0x1B	200Hz / 300Hz / 400Hz / 500Hz	50msec for each tone
0x1C	400Hz / 300Hz	150msec for each tone
0x1D	300Hz / 400Hz	150msec for each tone
0x1E	300Hz / mute / 400Hz / mute / 500Hz / mute / 1000Hz	100msec for each tone
0x1F	1000Hz / mute /500Hz / mute / 400Hz / mute /300Hz	100msec for each tone
0x20	ROM build-in multi tone melody	
0x21	ROM build-in multi tone melody	
0x22	ROM build-in multi tone melody	
0x23	ROM build-in multi tone melody	
0x24	ROM build-in multi tone melody	
0x25	ROM build-in multi tone melody	
0x26	ROM build-in multi tone melody	

Stored Voice prompt

Tone_type	Voice Prompt Description
0x80	VP_POWER_ON
0x81	VP_POWER_OFF
0x82	VP_PAIRING_MODE
0x83	VP_PAIRING_COMPLETE
0x84	VP_PAIRING_NOT_COMPLETE

.....continued

Tone_type	Voice Prompt Description
0x85	VP_CONNECTED
0x86	VP_DISCONNECTED
0x87	VP_INCOMING_CALL
0x88	VP_REJECT_CALL
0x89	VP_CALL_END
0x8A	VP_VOICE_DIAL
0x8B	VP_REDIAL
0x8C	VP_BATTERY_L
0x8D	VP_BATTERY_M
0x8E	VP_BATTERY_H
0x8F	VP_CHARGING_START
0x90	VP_CHARGING_OK
0x91	VP_MAX_VOL
0x92	VP_MIN_VOL
0x93	VP_TONE_SET

Parameter for Utility_Function_Type 0x03: Length: 1 Byte

Value	Parameter Description
0x00	To force BTM into the non-connectable mode
0x01	To resume BTM to the normal mode

Parameter for Utility_Function_Type 0x04: Length: 1 Byte

Value	Parameter Description
0x00	Adapter plugged in
0x01	Adapter unplugged
0x02 ⁽¹⁾	USB plugged in
0x03 ⁽¹⁾	USB unplugged

Note:

1. Check the exception notice in summary table.

Parameter for Utility_Function_Type 0x05: Length: 1 Byte

Value	Parameter Description
0x01	To indicate BTM that remote device supports TTS engine. The BTM shall disable internal TTS engine.

.....continued	
Value	Parameter Description
Others	Reserved

Parameter for Utility_Function_Type 0x06: Length: 1 Byte

Value	Parameter Description
0xXX	Reserved

Parameter for Utility_Function_Type 0x07:

Value	Parameter Description
parameter[0]	Version length. For example: v1.05 length is 3
parameter[1~length]	Version value. For example: v1.05 value is 1 0 5

Parameter for Utility_Function_Type 0x08: Length: 1 Byte

Value	Parameter Description
0x00	Battery power with low battery
0x01	Adapter power with low battery
0x02	Battery power
0x03	Adapter power

Parameter for Utility_Function_Type 0x09:

Value	Parameter Description
parameter[0]	Vendor EEPROM offset
parameter[1]	Update length
parameter[2~length+1]	Update data

Parameter for Utility_Function_Type 0x0A: Length: 1 Byte

Value	Parameter Description
0xXX	Reserved

Parameter for Utility_Function_Type 0x0B: Length: 1 Byte

Value	Parameter Description
0xXX	Reserved

Parameter for Utility_Function_Type 0x0C: Length: 1 Byte

Value	Parameter Description
0x00	L+R

.....continued	
Value	Parameter Description
0x01	L+L
0x02	R+R
0x03	(L+R)/2

Parameter for Utility_Function_Type 0x0D Customized MCU report:

Size: 2 BYTE

Parameter	Parameter Description
0x00 00	MCU Power State is OFF
0x00 01	MCU Power State is ON
0x01 00	MCU Exit Demo Mode
0x01 01	MCU Enter Demo Mode
Others	Reserved

Parameter for Utility_Function_Type 0x0E Customized MCU request:

Size: 1 BYTE

Return error: Length: 1 Byte

Parameter	Parameter Description
0x00	Inquiry Unique ID
Others	Reserved

Value	Description	Condition
0x03	Parameter error	Parameter incorrect

5.6.18 Event_Ack (0x14)

Command	Op Code	Command Parameters	Return Event
Event_Ack	0x14	Event_ID	

Description:

This command is used for MCU to acknowledge the received BTM event.

Precondition:

None.

Command Parameters:

Event_ID Length: 1 Byte

Value	Parameter Description
0xXX	Event ID of the event which needs to be acknowledged

5.6.19 Additional_Profile_Link_Setup (0x15)

Command	Op Code	Command Parameters	Return Event
Additional_Profile_Link_Setup	0x15	Data_Base_Index,Linked_Profile	

Description:

This command is used to initiate other profile connection based on the already existing link profiles. For example, user can initiate HF/HS profile connection if HF/HS is in the standby mode and without connection and there is already one A2DP/AVRCP/SPP connected profile.

Precondition:

- Asynchronous Connection Less (ACL) link should be connected and
- A2DP or AVRCP or HF or SPP profile should be connected

Command Parameters:

Data_Base_Index: Length: 1 Byte

Value	Parameter Description
0x00	Database Index 0 that linked profile occupied
0x01	Database Index 1 that linked profile occupied

Linked_Profile: Length: 1 Byte

Value	Parameter Description
0x00	To initiate HF/HS profile connection
0x01	To initiate A2DP profile connection
0x02	To initiate iAp/SPP profile connection

Return error: Length: 1 Byte

Value	Description	Condition
0x01	Command disallow	No ACL link or no any A2DP/AVRCP/HFP/HSP profile connected

5.6.20 Read_Linked_Device_Information (0x16)

Command	Op Code	Command Parameters	Return Event
Read_Linked_Device_Information	0x16	Data_Base_Index, Type	Read_Linked_Device_Information_Reply

Description:

This command is used to retrieve the connected device profile information or local information based on the 'Type' parameter value.

Precondition:

- For Type 0x00: ACL link should be connected
- For Type 0x01: HF should be in connected state
- For Type 0x02: SPP should be in connected state

- For Type 0x03: AVRCP should be in connected state
- For Type 0x04 and 0x05: None
- For Type 0x06: A2DP should be in connected state.

Command Parameters:

Data_Base_Index: Length: 1 Byte

Value	Parameter Description
0x00	Database 0 for dedicate link
0x01	Database 1 for dedicate link

Type: Length: 1 Byte

Value	Parameter Description
0x00	Query device name
0x01	Query in-band ringtone status
0x02	Query whether remote device is iAP or standard SPP device
0x03	Query whether remote device supports AVRCP 1.3 or not
0x04	Query HF/A2DP gain
0x05	Query Line-In gain
0x06	Query A2DP codec

Return error: Length: 1 Byte

Value	Description	Condition
0x01	Command disallow	<ul style="list-style-type: none"> • Type 0x00: no ACL link • Type 0x01: no HF connection • Type 0x02: no SPP connection • Type 0x03: no AVRCP connection
0x03	Parameter error	Incorrect parameter

5.6.21 Profile_Link_Back (0x17)

Command	Op Code	Command Parameters	Return Event
Profile_Link_Back	0x17	Type, Device_Index, Profile, BT_Addr	Report_Link_Back_Status

Description:

This command is used to trigger the link for specific profiles to the devices in paired list.

Precondition:

Paired device list should exist.

Command Parameters:

Type: Length: 1 Byte

Value	Parameter Description	Sub Parameter
0x00	Connect to last device: If last device supports HF/HS, then initiate HF/HS connection, otherwise initiate A2DP connection	NA
0x01	Initiate HF/HS connection to last HF/HS device	NA
0x02	Initiate A2DP connection to last A2DP device	NA
0x03	Initiate SPP/iAP connection to last SPP/iAP device	NA
0x04	Initiate connection to dedicate device index with the profile specified by the Profile parameter	Device_Index, Profile
0x05	Initiate connection to the specified BT address	Device_Index, Profile, BT_Addr
0x06	Initiate connection to the multi-point mode	NA

Device_Index: Length: 1 Byte

Value	Parameter Description
0x00	Device index. Range is from 0 to 7.

Profile: Length: 1 Byte

Value	Parameter Description
0x00	The profile is determined by BTM's E2PROM record
Bit0	HS profile
Bit1	HF profile
Bit2	A2DP profile

BT_Addr: Length:6 Bytes

Value	Parameter Description
0XXXXXXXXXXXXX	The Bluetooth address of the target device that BTM will try to create a connection

Return error: Length: 1 Byte

Value	Description	Condition
0x01	Command disallow	nSPK is creating connection TYPE=0x01: The last device does not support HF/HS/A2DP Incorrect TYPE

5.6.22 Disconnect (0x18)

Command	Op Code	Command Parameters	Return Event
Disconnect	0x18	Disconnection_Flag	BTM_Status

Description:

This command is used to cancel the ongoing link back procedure or disconnect all the select linked profiles. BTM will disconnect Asynchronous Connection Less (ACL) link if all of the profiles are disconnected.

Precondition:

None.

Command Parameters:

Disconnection_Flag: (Sony Project) Length: 1 Byte

Value	Parameter Description
Bit 0	Cancel page before ACL connection has been created
Bit 1	Disconnect all of the HF connections
Bit 2	Disconnect all of the A2DP connections
Bit 3	Disconnect all of the SPP connections
Bit 4	Disconnect all of the BLE connections

Disconnection_Flag: (Other Projects) Length: 1 Byte

Value	Parameter Description
Bit 0	Cancel page before ACL connection has been created
Bit 1	Disconnect all of the HF connections
Bit 2	Disconnect all of the A2DP connections
Bit 3	Disconnect all of the SPP/BLE (if BLE enable) connections
Bit 4	Disconnect all of the SPP connections
Bit 5	Disconnect BLE connection

Return error: Length: 1 Byte

Value	Description	Condition
0x03	Parameter error	Incorrect disconnection_flag parameter

5.6.23 User_Confirm_SSP_Req_Reply (0x1A)

Command	Op Code	Command Parameters	Return Event
User_Confirm_SSP_Req_Reply	0x1A	Data_Base_Index, User_Response	

Description:

This command is used to reply to a User_Confirm_SSP_Req event and indicates that the user selected "yes" or "no".

Precondition:

ACL link should be connected

Command Parameters:

Data_Base_Index: Length: 1 Byte

Value	Parameter Description
0x00	Database 0 that simple pairing is ongoing
0x01	Database 1 that simple pairing is ongoing

User_Response: Length: 1 Byte

Value	Parameter Description
0x00	User selected "yes"
0x01	User selected "no"

Return error: Length: 1 Byte

Value	Description	Condition
0x01	Command disallow	No ACL connection

5.6.24 Set_HF_Speaker_Gain_Level (0x1B)

Command	Op Code	Command Parameters	Return Event
Set_HF_Speaker_Gain_Level	0x1B	Data_Base_Index, Gain_Level	

Description:

This command is used to set HF Speaker gain of BTM.

Precondition:

HF should be in connected state

Command Parameters:

Data_Base_Index: Length: 1 Byte

Value	Parameter Description
0x00	Database 0 that related to a dedicate HF device
0x01	Database 1 that related to a dedicate HF device

Gain_Level: Length: 1 Byte

Value	Parameter Description
0x00 – 0x0F	HF speaker gain level

Return error: Length: 1 Byte

Value	Description	Condition
0x01	Command disallow	No HF connection

5.6.25 EQ_Mode_Setting (0x1C)

Command	Op Code	Command Parameters	Return Event
EQ_Mode_Setting	0x1C	EQ_Mode, Reserved	EQ_Mode_Indication

Description:

This command is used to set the EQ mode of BTM for audio playback.

Precondition:

EQ Mode should be enabled by using DSP configuration tool.

Command Parameters:

EQ_Mode: Length: 1 Byte

Value	Parameter Description
0x00	EQ_MODE_OFF
0x01	EQ_MODE_SOFT
0x02	EQ_MODE_BASS
0x03	EQ_MODE_TREBLE
0x04	EQ_MODE_CLASSICAL
0x05	EQ_MODE_ROCK
0x06	EQ_MODE_JAZZ
0x07	EQ_MODE_POP
0x08	EQ_MODE_DANCE
0x09	EQ_MODE_RNB
0x0A	EQ_MODE_USER1
Others	Reserved

Reserved: Length: 1 Byte

Value	Parameter Description
0xXX	Reserved

Return error: Length: 1 Byte

Value	Description	Condition
0x01	Command disallow	DSP EQ mode is not enabled

5.6.26 DSP_NR_CTRL (0x1D)

Command	Op Code	Command Parameters	Return Event
DSP_NR_CTRL	0x1D	Cmd_Type	

Description:

This command is used to set the noise reduction for voice link.

Precondition:

None.

Command Parameters:

Cmd_Type: Length: 1 Byte

Value	Parameter Description
0x18	ENABLE_Mic_NR
0x19	DISABLE_Mic_NR
0x1B	ENABLE_SPK_NR
0x1C	DISABLE_SPK_NR
Others	Reserved

Return error: Length: 1 Byte

V1.03

Value	Description	Condition
0x01	Command disallow	DSP NR module disable
0x03	Parameter error	Parameter incorrect

5.6.27 GPIO_CTRL (0x1E)

Command	Op Code	Command Parameters	Return Event
GPIO_CTRL	0x1E	IO_Ctrl_Mask_P0, IO_Ctrl_Mask_P1, IO_Ctrl_Mask_P2, IO_Ctrl_Mask_P3, IO_Setting_P0, IO_Setting_P1, IO_Setting_P2, IO_Setting_P3, Output_Value_P0, Output_Value_P1, Output_Value_P2, Output_Value_P3,	Report_Input_Signal_Level

Description:

This command is used to control the specific GPIOs as input level detection or output level drive. For input level detection configuration, BTM reports the input signal level to MCU when input signal level is changed.

Note: For GPIOs configured as input, Report_Input_Signal_Level event shall be sent under two conditions:

1. When BTM receives input setting command
2. When input GPIO input signal level is changed

Precondition:

None.

Command Parameters:

IO_Ctrl_Mask_P0: Length: 1 Byte

Value	Parameter Description
0bXXXXXXXX	Bit mask of P0 for IO control setting. MCU sets the bit value to 0 to control corresponding pin, otherwise sets to 1. Bit 0: P0_0 IO control setting mask. Bit 1: P0_1 IO control setting mask.

IO_Ctrl_Mask_P1: Length: 1 Byte

Value	Parameter Description
0bXXXXXXXX	Bit mask of P1 for IO control setting. MCU sets the bit value to 0 to control corresponding pin, otherwise sets to 1. Bit 0: P1_0 IO control setting mask. Bit 1: P1_1 IO control setting mask.

IO_Ctrl_Mask_P2: Length: 1 Byte

Value	Parameter Description
0bXXXXXXXX	Bit mask of P2 for IO control setting. MCU sets the bit value to 0 to control corresponding pin, otherwise sets to 1. Bit 0: P2_0 IO control setting mask. Bit 1: P2_1 IO control setting mask.

IO_Ctrl_Mask_P3: Length: 1 Byte

Value	Parameter Description
0bXXXXXXXX	Bit mask of P3 for IO control setting. MCU sets the bit value to 0 to control corresponding pin, otherwise sets to 1. Bit 0: P3_0 IO control setting mask. Bit 1: P3_1 IO control setting mask.

IO_Setting_P0: Length: 1 Byte

Value	Parameter Description
0bXXXXXXXX	Setting P0 GPIO as input or output mode IO bit setting of P0 for input or output configuration. 0: input 1: output Bit 0: P0_0 IO control setting Bit 1: P0_1 IO control setting

IO_Setting_P1: Length: 1 Byte

Value	Parameter Description
0bXXXXXXXX	Setting P1 GPIO as input or output mode IO bit setting of P1 for input or output configuration. 0: input 1: output Bit 0: P1_0 IO control setting Bit 1: P1_1 IO control setting

IO_Setting_P2: Length: 1 Byte

Value	Parameter Description
0bXXXXXXXX	Setting P2 GPIO as input or output mode IO bit setting of P2 for input or output configuration. 0: input 1: output Bit 0: P2_0 IO control setting Bit 1: P2_1 IO control setting

IO_Setting_P3: Length: 1 Byte

Value	Parameter Description
0bXXXXXXXX	Setting P3 GPIO as input or output mode IO bit setting of P3 for input or output configuration. 0: input. 1: output Bit 0: P3_0 IO control setting Bit 1: P3_1 IO control setting

Output_Value_P0: Length: 1 Byte

Value	Parameter Description
0bXXXXXXXX	Output level of P0.x GPIOs setting. It is used for IO_Setting_P0.x as output only.

Output_Value_P1: Length: 1 Byte

Value	Parameter Description
0bXXXXXXXX	Output level of P1.x GPIOs setting. It is used for IO_Setting_P1.x as output only.

Output_Value_P2: Length: 1 Byte

Value	Parameter Description
0bXXXXXXXX	Output level of P2.x GPIOs setting. It is used for IO_Setting_P2.x as output only.

Output_Value_P3: Length: 1 Byte

Value	Parameter Description
0bXXXXXXXX	Output level of P3.x GPIOs setting. It is used for IO_Setting_P3.x as output only.

5.6.28 MCU_UART_Rx_Buffer_Size (0x1F)

Command	Op Code	Command Parameters	Return Event
MCU_UART_Rx_Buffer_Size	0x1F	Max_MCU_UART_Rx_Buffer_Size	

Description:

This command is used to indicate to the BTM about the maximum UART Rx buffer size. The default value is 256 Bytes.

Precondition:

None.

Command Parameters:

Max_MCU_UART_Rx_Buffer_Size: Length: 2 Bytes

Value	Parameter Description
0xXXXX	The maximum UART receiver buffer size of Host MCU.

5.6.29 Voice_Prompt_Cmd (0x20)

Command	Op Code	Command Parameters	Return Event
Voice_Prompt_Cmd	0x20	Cmd_Type, Parameter, Voice_Data	Report_Voice_Prompt_Status

Description:

This command is used to control BTM voice prompt function. Host MCU sets voice prompt control parameter and sends voice prompt data after receiving the event Report_Voice_Prompt_Status with ready status.

Precondition:

For Cmd_Type 0x00: None

For Cmd_Type 0x01: Voice_Prompt_Cmd(0x20) should be called with Cmd_Type 0x00

For example:

1. 0x20 0x00 0x01
2. 0x20 0x01 0x00 "RAW data" which data size is smaller than 480 bytes

Command Parameters:

Cmd_Type: Length: 1 Byte

Value	Parameter Description
0x00	Voice prompt settings
0x01	Voice prompt data
Others	Reserved

Parameter: for Cmd_Type 0x00 Length: 1 Byte

Value	Parameter Description
0x00	Stop to play voice prompt and skip the previous voice data.
0x01	Initial, high priority: Force to stop current tone and clean tone queue then play the new tone.
0x02	Initial, low priority: Add the new tone into the tone queue.
Others	Reserved

Parameter: for Cmd_Type 0x01 Length: 1 Byte

Value	Parameter Description
0x00	Single packet, if voice data size is less than 480
0x01	Fragmented start packet
0x02	Fragmented continue packet
0x03	Fragmented end packet
Others	Reserved

Voice_Data: for Cmd_Type 0x00 Length: N Bytes

Value	Parameter Description
0xXXXX	Invalid

Voice_Data: for Cmd_Type 0x01 Length: N Bytes

Value	Parameter Description
0xXXXX	Voice prompt data

Return error: Length: 1 Byte

Value	Description	Condition
0x01	Command disallow	DSP ringtone state is ready
0x04	BTM busy	BTM is busy
0x03	Parameter error	Parameter incorrect

5.6.30 Set_Overall_Gain (0x23)

Command	Op Code	Command Parameters	Return Event
Set_Overall_Gain	0x23	Data_Base_Index, Mask, Type, Gain1, Gain2, Gain3	

Description:

This command is used to set overall gain that includes `hf`, `a2dp` and `line_in`.

Precondition:

None.

Command Parameters:

Data_Base_Index: Length: 1 Byte

Value	Parameter Description
0x00	Database 0
0x01	Database 1

Mask: Length: 1 Byte

Value	Parameter Description
0xXX	Set '1' to indicate the gain need to change Bit0: A2DP gain Bit1: HF gain Bit2: Line_In gain Bit3: PCM gain

Type: Length: 1 Byte

Value	Parameter Description
0x01	Volume up
0x02	Volume down
0x03	Set absolute gain level
0x04	Set absolution gain value (only for AVRCP1.5)
0x05	Synchronize volume setting from MCU

Gain1: Effective when bit0 of mask is 1 or type is 4, 5 Length: 1 Byte

Value	Parameter Description
0xXX	type=1, 2 X type=3 : A2DP gain level 0~15 0x00~0x0F type=4, 5 : A2DP absolute gain value 0%~100% 0x00~0x7F Other types are reserved

Gain 2: Effective when bit1 of mask is 1 or type is 5 Length: 1 Byte

Value	Parameter Description
0xXX	type=1, 2, 4 X type=3 : HF gain level 0~15 0x00~0x0F type=5 : HF gain percentage 0%~100% 0x00~0x7F Other types are reserved

Gain 3: Effective when bit2 of mask is 1 or type is 5 Length: 1 Byte

Value	Parameter Description
0xXX	type=1, 2, 4 X type=3 : line in gain level 0~15 0x00~0x0F type=5 : line in gain percentage 0%~100% 0x00~0x7F Other types are reserved

Return error: Length: 1 Byte

Value	Description	Condition
0x01	Command disallow	Type 0x03: mask profiles are not connected Type 0x04: AVRCP is not connected
0x03	Parameter error	Incorrect parameter: Gain value is bigger than maximum gain setting

5.6.31 Read_BT_M_Setting (0x24)

Command	Op Code	Command Parameters	Return Event
Read_BT_M_Setting	0x24	Setting_Type, Reserved	REPORT_TYPE_BT_M_SETTING

Description:

This command is used to read setting status of BTM.

Precondition:

None.

Command Parameters:

Setting_Type: Length: 1 Byte

Value	Parameter Description
0x00	Read pairing timeout value

.....continued	
Value	Parameter Description
0x01	Read supported codec type
0x02	Read BTM Standby mode status
others	Reserved

Reserved: Length: 1 Byte

Value	Parameter Description
0xXX	Reserved

Return error: Length: 1 Byte

Value	Description	Condition
0x03	Parameter error	Incorrect parameter

5.6.32 Read_BT_M_Battery_Charger_Status (0x25)

Command	Op Code	Command Parameters	Return Event
Read_BT_M_Battery_Charger_Status	0x25	Type	BTM_Battery_Status BTM_Charging_Status

Description:

This command is used to read either Battery or Charger status of BTM.

Precondition:

None.

Command Parameters:

Type: Length: 1 Byte

Value	Parameter Description
0x00	Read battery status
0x01	Read charger status
Others	Reserved

Return error: Length: 1 Byte

Value	Description	Condition
0x03	Parameter error	Parameter incorrect.

5.6.33 MCU_Update_Cmd (0x26)

Command	Op Code	Command Parameters	Return Event
MCU_Update_Cmd	0x26	Action	

Description:

This command is used to inform BTM about MCU boot loader status.

Precondition:

None.

Command Parameters:

Action: Length: 1 Byte

Value	Parameter Description
0x00	Start to update and report the total size
0x01	MCU ready to receive data from BTM
0x02	MCU update finish
Others	Reserved

Return error: Length: 1 Byte

Value	Description	Condition
0x03	Parameter error	Incorrect parameter

5.6.34 Report_Battery_Capacity (0x27)

Command	Op Code	Command Parameters	Return Event
Report_Battery_Capacity	0x27	Capacity	

Description:

This command is used to inform BTM about the system battery capacity (unit in percentage).

Precondition:

None.

Command Parameters:

Capacity: Length: 1 Byte

Value	Parameter Description
0xXX	Battery capacity, range is from 0 to 100 and unit in percentage

Return error: Length: 1 Byte

Value	Description	Condition
0x03	Parameter error	Parameter incorrect.

5.6.35 LE_ANCS_Service_Cmd (0x28)

Command	Op Code	Command Parameters	Return Event
LE_ANCS_Service_Cmd	0x28	SubCommand_Type, SubCommand_Payload	

Description:

This command is used to access Apple® Notification Center Service (ANCS), and get many kinds of notifications that are generated on iOS devices by the Bluetooth Low Energy link.

Precondition:

LE should be in connected state.

Command Parameters:

Length: 1 Byte

SubCommand_Type:

Value	Parameter Description
0x00	ANCS search
0x01	ANCS subscribe
0x02	ANCS GetNotification attribute
0x03-0xFF	Reserved

SubCommand_Payload: for SubCommand_Type 0x00

Length: 0 Byte

Value	Parameter Description
N/A	NA

SubCommand_Payload: for SubCommand_Type 0x01

Length: 1 Byte

Value	Parameter Description
0x00	Un-subscribe ANCS
0x01	Subscribe ANCS

SubCommand_Payload : for SubCommand_Type 0x02

Length: N Bytes

Value	Parameter Description
	The format of a GetNotification attribute command

Return error:

Length: 1 Byte

Value	Description	Condition
0x01	Command disallow	No LE connection
0x03	Parameter error	For other than given SubCommand_Type
0x04	BTM busy	BTM is busy

5.6.36 LE_Signaling_Cmd (0x29)

Command	Op Code	Command Parameters	Return Event
LE_Signaling_Cmd	0x29	SubCommand_Type, SubCommand_Payload	LE_Signaling_Event for SubCommand 0x00.

Description:

This command is used for the Bluetooth Low Energy signaling control.

Precondition:

None.

Command Parameters:

SubCommand_Type (Length: 1 Byte):

Value	Parameter Description
0x00	Query LE status
0x01	LE Advertising Control
0x02	LE Connection Parameters Update REQ
0x03	LE Advertising Interval Update
0x04	LE Advertising Type
0x05	LE Advertising Data
0x06	LE Scan Response Data
0x07-0xFF	Reserved

SubCommand_Payload : for SubCommand_Type 0x00 (Length: 0 Byte)

Value	Parameter Description
N/A	NA

SubCommand_Payload : for SubCommand_Type 0x01 (Length: 1 Byte)

Value	Parameter Description
0x00	Disable advertising
0x01	Enable advertising

SubCommand_Payload : for SubCommand_Type 0x02 (Length: 8 Bytes)

Value	Parameter Description
0xFFFF(2 Bytes)	Connection Interval Minimum: Range from 0x0006 to 0x0C80 (7.5ms to 4s), minimum value for the connection event interval.

.....continued

Value	Parameter Description
0xFFFF(2 Bytes)	Connection Interval Maximum: Range from 0x0006 to 0x0C80 (7.5ms to 4s), maximum value for the connection event interval.
0xFFFF(2 Byte)	Slave Latency: Range from 0 to ((Supervision Timeout / (Connection Interval x2)) -1) and shall also be less than 500, the Slave Latency parameter defines the number of consecutive connection events that the slave device is not required to listen for the master.
0xFFFF(2 Bytes)	Supervision: Range from 0x000A to 0x0C80 (100ms ~ 32s), supervision timeout for the LE Link

SubCommand_Payload : for SubCommand_Type 0x03 (Length: 2 Bytes)

Value	Parameter Description
	Advertising interval Range: 0x0020 ~ 0x4000 Unit: 0.625ms

SubCommand_Payload : for SubCommand_Type 0x04 Length: 1 Byte

Value	Parameter Description
0x00	Connectable undirected advertising
0x01	Reserved
0x02	Scannable undirected advertising
0x03	Non connectable undirected advertising

SubCommand_Payload : for SubCommand_Type 0x05 (Length: 1 ~ 32 Bytes)

Value	Parameter Description
	Reserved (1 byte) Advertising data (max to 31 bytes)

SubCommand_Payload : for SubCommand_Type 0x06 (Length: 1 ~ 32 Bytes)

Value	Parameter Description
	Reserved (1 byte) Scan response data (maximum up to 31 bytes)

Return error: (Length: 1 Byte)

Value	Description	Condition
0x03	Parameter error	For other than given SubCommand_Type

.....continued

Value	Description	Condition
0x01	Command disallow	LE status incorrect

5.6.37 nSPK_Vendor_Cmd (0x2A)

Command	Op Code	Command Parameters	Return Event
nSPK_Vendor_Cmd	0x2A	SPK_Index, Parameter	

Description:

This command is used to send the vendor nSPK command, after this command is sent to another SPKs, SPK may respond OK, ERROR, or no response.

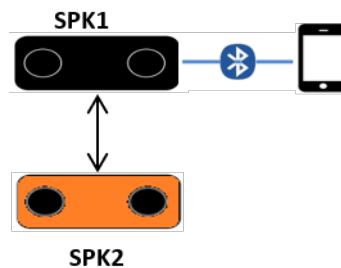

Precondition:

None.

Command Parameters:

SPK_Index: for SPK1 (Length: 1 Byte)

Value	Parameter Description
Don't Care	Reserved, in Stereo mode, BTM

Parameter: for SPK2 (Length: 1 Byte)

SPK_Index	Parameter Content	Parameter Description
0x00	Invalid payload data	They are used to show the status of slave SPK
0x01~0x1F	Valid payload data	This data is transferred to SPK Master and SPK Master's MCU by E34
0x20~0xFF	Invalid payload data	

Parameter: for SPK1

For 9 bytes format	Parameter Content	Parameter Description
Byte[0] Byte[1]	High byte of following data length, Low byte of following data length	
Byte[2]~Byte[10]	Payload	9 bytes are available

For 11 bytes format	Parameter Content	Parameter Description
Byte[0] Byte[1]	High byte of following data length, Low byte of following data length	
Byte[2] ~Byte[12]	Payload	11 bytes are available

Return error: (Length: 1 Byte)

Value	Description	Condition
0x03	Parameter error	SPK_Inde 0x00: parameter incorrect

5.6.38 Read_nSPK_Link_Status (0x2B)

Command	Op Code	Command Parameters	Return Event
Read_nSPK_Link_Status	0x2B	Reserved	Report_nSPK_Link_Status

Description:

This command is used to query the nSPK link status.

Precondition:

None.

Command Parameters:

Reserved: (Length: 1 Byte)

Value	Parameter Description
0xXX	Reserved

5.6.39 nSPK_Sync_Audio_Effect (0x2C)

Command	Op Code	Command Parameters	Return Event
nSPK_Sync_Audio_Effect	0x2C	audio_effect_type, audio_effect_value	

Description:

It is used for Master SPK to synchronize audio effect to Slave SPK in the nSPK mode.

Precondition:

None.

Command Parameters:

audio_effect_type: (Length: 1 Byte)

Value	Parameter Description
0xXX	Vendor defined audio effect type

audio_effect_value: (Length: 1 Byte)

Value	Parameter Description
0xXX	Audio effect value

5.6.40 LE_GATT_CMD (0x2D)

Command	Op Code	Command Parameters	Return Event
LE_GATT_CMD	0x2D	Sub_Cmd_Type, Parameters	

Description:

Generic BLE GATT command for controlling MCU for specific GATT operations. This command is followed by sub commands for specific GATT operations. The sub commands are detailed in the following subsections:

Precondition:

None.

5.6.40.1 Send_Characteristic_Value (0x00)

This command is used to send characteristic value to GATT client. It can be used for both notification and indication of char value to GATT client.

Command	Sub-Op Code	Command Parameters	Return Event
Send_Characteristic_Value	0x00	Connection_Handle, Characteristic_Value_Handle, Characteristic_Value	Status

Command Parameters:

Connection_Handle: (Length: 1 Byte)

Value	Parameter Description
0xXX	Connection handle

Characteristic_Value_Handle: (Length: 2 Bytes)

Value	Parameter Description
0xXX	Characteristic value handle

Characteristic_Value (Length: 1 to 20 Bytes):

Value	Parameter Description
0xXX	Characteristic value

5.6.40.2 Send_Write_Response (0x01)

This command is used to manually respond write request to the GATT client. DSPK sends "Write Response" with error code 0x00. Otherwise, "Error Response" with corresponding error code is sent. This command should only be sent after receiving write request.

Command	Sub-Op Code	Command Parameters	Return Event
Send_Write_Response	0x01	Connection_Handle, Request_Opcode, Attribute_Handle, Error_Code	Status

Command Parameters:

Connection_Handle: (Length: 1 Byte)

Value	Parameter Description
0xXX	Connection handle

Request_Opcode: (Length: 1 Byte)

Value	Parameter Description
0xXX	Write Request. The op-code of the request to respond.

Attribute_Handle: (Length: 2 Bytes)

Value	Parameter Description
0xXX	The handling of the attribute which is requested to perform

Error_Code: Length: 1 Byte

Value	Parameter Description
0x00	No error. Send write response
0x01	Invalid handle
0x02	Read not permitted
0x03	Write not permitted
0x04	Invalid PDU
0x05	Insufficient authentication
0x06	Request not supported
0x07	Invalid offset
0x08	Insufficient authorization
0x09	Prepare queue full
0x0A	Attribute not found
0x0B	Attribute not long
0x0C	Insufficient encryption key size
0x0D	Invalid attribute value length
0x0E	Unlikely error
0x0F	Insufficient encryption
0x10	Unsupported group type
0x11	Insufficient resources
0x12 – 0x7F	Reserved
0x80 – 0x9F	Application defined errors
0xA0 – 0xDF	Reserved

.....continued	
Value	Parameter Description
0xE0 – 0xFF	Common profile and service error codes

5.6.40.3 Update_Characteristic_Value (0x02)

This command is used to update existing characteristic value of local attribute database

Command	Sub-Op Code	Command Parameters	Return Event
Update_Characteristic_Value	0x02	Characteristic_Value_Handle, Characteristic_Value	Status

Command Parameters:

Characteristic_Value_Handle: (Length: 2 Byte)

Value	Parameter Description
0xXX	Characteristic value handle

Characteristic_Value: (Length: 1 Byte)

Value	Parameter Description
0xXX	Characteristic value

5.6.40.4 Read_Local_Characteristic_Value (0x03)

This command is used to read existing characteristic value from local attribute database.

Command	Sub-Op Code	Command Parameters	Return Event
Read_Local_Characteristic_Value	0x03	Characteristic_Value_Handle	Status Read_Local_Char_Value_Res

Command Parameters:

Characteristic_Value_Handle: (Length: 2 Byte)

Value	Parameter Description
0xXX	Characteristic value handle

5.6.40.5 Read_Local_All_Primary_Services (0x04)

This command is used to read all primary services from local attribute database.

Command	Sub-Op Code	Command Parameters	Return Event
Read_Local_All_Primary_Services	0x04	None	Status Discover_All_Primary_Services_Res

Command Parameters:

None.

5.6.40.6 Read_Local_Specific_Primary_Service (0x05)

This command is used to read specific primary service from local attribute database.

Command	Sub-Op Code	Command Parameters	Return Event
Read_Local_Specific_Primary_Service	0x05	Service_UUID	Status Read_Local_Specific_Primary_Service_Characteristic_Res Read_Local_All_Char_Descriptors_Res

Command Parameters:

Service_UUID: (Length: 2/16 Byte)

Value	Parameter Description
0xXX	16-bit Bluetooth UUID or 128-bit UUID

Note: UUID should be in reverse byte order. For example, if UUID is 0x180D, then send as 0x0D18.

5.6.41 LE_App_Cmd (0x2F)

Command	Op Code	Command Parameters	Return Event
LE_App_Cmd	0x2F	Sub_Cmd_Type, Parameter	

Description:

This command is used for LE application.

Precondition:

For Sub_Cmd_Type 0x5D: LE state should be connected

For Sub_Cmd_Type 0x5C: None

5.6.41.1 Set_Device_Name (0x5C)

This command is used to set the LE device name.

Command	Sub-Op Code	Command Parameters	Return Event
Set_Device_Name	0x5C	Name_Length, Name_String	Status

Command Parameters:

Name_Length: (Length: 1 Byte)

Value	Parameter Description
0xXX	Length of the LE device name

Name_String: (Length: 1 to 20 Bytes)

Value	Parameter Description
0xXX..	LE device name string

5.6.41.2 Get_Att_MTU_Size (0x5D)

This command is used to get the Att MTU size. Att MTU size is notified to the host MCU by using the event REPORT_LE_GATT_EVENT (0x39) with the sub event type Get_Att_MTU_Size_Res (0x05).

Command	Sub-Op Code	Command Parameters	Return Event
Get_Att_MTU_Size	0x5D	None	Status, REPORT_LE_GATT_EVENT (0x39) with the sub-event type Get_Att_MTU_Size_Res (0x05)

Command Parameters:

None.

5.6.42 DSP_Runtime_Program (0x30)

Command	Op Code	Command Parameters	Return Event
DSP_Runtime_Program	0x30	Type, Cmd_Buffer	

Description:

This command is used to change the EQ parameter of the DSP in run time.

Precondition:

EQ Mode should be enabled by using DSP configuration tool for type 0x13.

Command Parameters:

Type: (Length: 1 Byte)

Value	Parameter Description
0x13	To Set Audio EQ parameter
0x2D	To Set Sound Effect parameter

Cmd Buffer: for Type 0x13 (Length: 84 Bytes)

Value	Parameter Description
0xXX	Audio EQ Parameter //SOFT 00000000c039631500000000c051eb8540000007fffffff18b42aef45232a2700000000 00 000000000000000000000000276e41b8 //BASS 36b0f0758a53021235a323fc8b5e7fa738b3d27e875cb8cf3a61d55085aef0ef3ed11863 812f30873f623e57809E0ae7000 00000000000000000000000409a1c9f //ROCK 2d35264093ba07232a70b4a7967869291997fe35b268d8f01ae7c4a9b1460ebb3916b 5b986f9e32239a05624867055943eb27d61814dcb773f5672b280a9d684e648e12c13 247096fada28801d6d1440623817ec

Cmd Buffer: for Type 0x2D (Length: 7 Bytes)

Value	Parameter Description
0xXX	Sound effect parameter //MBC table 4f914469dd0d00

Return error: (Length: 1 Byte)

Value	Description	Condition
0x01	Command disallow	For other than given Type and DSP Equalizer is not active

5.6.43 Read_Vendor_Eeprom_Data (0x31)

Command	Op Code	Command Parameters	Return Event
Read_Vendor_Eeprom_Data	0x31	Offset, Length	Report_Vendor_EEPROM_Data

Description:

This command is used to read the vendor EEPROM data.

Precondition:

None.

Command Parameters:

Offset: Length: 1 Byte

Value	Parameter Description
0xXX	Vendor EEPROM offset

Length: (Length: 1 Byte)

Value	Parameter Description
0xXX	Read Length

Return error: (Length: 1 Byte)

Value	Description	Condition
0x03	Parameter error	Data offset + Data_length is bigger than 32 (0x20)

5.6.44 Read_IC_Version_Info (0x32)

Command	Op Code	Command Parameters	Return Event
Read_IC_Version_Info	0x32	Reserved	Report_IC_Ver_Info

Description:

This command is used to read the IC version information.

Precondition:

None.

Command Parameters:

Reserved: (Length: 1 Byte)

Value	Parameter Description
0xXX	Reserved

5.6.45 Voice_Prompt_Ind_Cmd (0x33)

Command	Op Code	Command Parameters	Return Event
Voice_Prompt_Ind_Cmd	0x33	SubCommand Type, SubCommand Payload	

Description:

This command is used to select voice prompt language (English/ Japanese/ Chinese) and predefined voice prompt source.

Precondition:

None.

Command Parameters:

SubCommand Type: (Length: 1 Byte)

Value	Parameter Description
0x00	Voice prompt language selection
0x01	Voice prompt source selection

SubCommand_Payload: for SubCommand 0x00 (Length: 1 Byte)

Value	Parameter Description
0x00	English
0x01	Japanese
0x02	Chinese

SubCommand_Payload : for SubCommand 0x01 (Length: 1 Byte)

Value	Parameter Description
0x00	Fully charge
0x01	Battery about 75%
0x02	Battery about 50%
0x03	Battery about 20%
0x04	Please charge
0x05	Left
0x06	Right

.....continued	
Value	Parameter Description
0x07	Connected
0x08	Pairing mode
0x09	Double mode

Return error: (Length: 1 Byte)

Value	Description	Condition
0x03	Parameter error	Incorrect sub command parameter

5.6.46 Read_BTMLink_Mode (0x34)

Command	Op Code	Command Parameters	Return Event
Read_BTMLink_Mode	0x34	Reserved	Report_BTMLink_Mode

Description:

This command is used to read the last link mode, it can be used to identify the mode before giving the Porfile_Link_Back command.

Precondition:

None.

Command Parameters:

Reserved: (Length: 1 Byte)

Value	Parameter Description
0xXX	Reserved

5.6.47 Configure_Vendor_Parameter (0x35)

Command	Op Code	Command Parameters	Return Event
Configure_Vendor_Parameter	0x35	Opcode, (mandatory) Option, (mandatory) Length, (optional) Parameters (optional)	

Description:

This command is used to configure the vendor parameter.

Precondition:

None.

Command Parameters:

Opcode: (Length: 1 Byte)

Value	Parameter Description
0x00	Change Device Name: The device name in EEPROM is replaced by new device name parameter.
Others	Reserved

Option: (Length: 1 Byte)

Value	Parameter Description
0x00	Reserved, set it to 0x00

Length: (Length: 1 Byte)

Value	Parameter Description
0xXX	Length of the following parameter

Parameter: (Length: 1 Byte)

Value	Parameter Description
0xXX	New device name parameter

Return error: (Length: 1 Byte)

Value	Description	Condition
0x01	Command disallowed	Length is zero or bigger than 64 when Restore Device Name is used
0x03	Parameter error	Length is bigger than 23 when Change Device Name is used OpCode is incorrect

5.6.48 nSPK Exchange_Link_Info_Cmd (0x37)

Command	Op Code	Command Parameters	Return Event
nSPK Exchange_Link_Info_Cmd	0x37	Exchange_data	

Description:

This command is used for information exchange when creating CSB link. This command must be sent before creating CSB link if there is need to exchange data.

Precondition:

None.

Command Parameters:

Exchange_data: (Length: 16 Byte)

Value	Parameter Description
0XXXXX...	16 bytes exchanged data.

5.6.49 nSPK Set GIAC(0x38)

Command	Op Code	Command Parameters	Return Event
nSPK Set GIAC	0x38	GIAC	

Description:

This command is used to change the group code for CSB general pairing and the modification does not change the EEPROM settings.

Precondition:

None.

Command Parameters:

GIAC: (Length: 2 Byte)

Value	Parameter Description
0xXXXX...	GIAC value

5.6.50 READ_FEATURE_LIST (0x39)

Command	Op Code	Command Parameters	Return Event
READ_FEATURE_LIST	0x39	Reserved	Report_Read_Feature_List_Reply

Description:

This command is used to query the supported feature.

Precondition:

None.

Command Parameters:

Reserved: (Length: 1 Byte)

Value	Parameter Description
0xXX	Reserved

5.6.51 Personal_MSPK_GROUP_Control (0x3A)

Command	Op Code	Command Parameters	Return Event
Personal_MSPK_GROUP_Control	0x3A	Enable, Master_SPK_BD_ADDR	

Description:

This command is used to inform Slave_SPK to enable or disable personal MSPK group settings.

The Master_SPK_BD_ADDR is Master_SPK BT Device Address. Slave_SPK only accepts the MSPK connection for specific Master_SPK if personal MSPK group is enabled.

This command must be asserted before MSPK command is triggered.

Precondition:

None.

Command Parameters:

Enable: (Length: 1 Byte)

Value	Parameter Description
0x00	Disable this feature
0x01	Enable this feature

Master_SPK_BD_ADDR: (Length: 6 Byte)

Value	Parameter Description
0XXXXXXXXXXXX	The BT Device Address of Master_SPK. It is big-endian. Example: BT Device Address is "00:11:22:33:44:55". It must be represented as "0x001122334455".

5.6.52 UART_CMD_TEST_DEVICE (0x3B)

Command	Op Code	Command Parameters	Return Event
UART_CMD_TEST_DEVICE	0x3B	Test OP code	

Description:

This command is used to test the assigned device.

Precondition:

None.

Command Parameters:

Test OP code: Length: 1 Byte

Value	Parameter Description
0x00	Test CP chip
0x01 - 0xFF	Reserved

5.6.53 PBAP_Cmd(0x3F)

Command	Opcode	Command Parameters	Return Event
PBAP_Client_Cmd	0x3F	Sub_Opcode, Parameters	

5.6.53.1 Open_PBAP_Session

Command	Sub-Opcode	Command Parameters	Return Event
Open_PBAP_Session	0x00	Device_Identifier	

Description:

This command is used to establish a PBAP session with remote device.

Precondition:

None.

Command Parameters:

Device_Identifier: (Length: 1 Byte)

Value	Parameter Description
0xXX	Device Identifier

5.6.53.2 Close_PBAP_Session

Command	Sub-Opcode	Command Parameters	Return Event
Clos_PBAP_Session	0x01	Device_Identifier	

Description:

This command is used to disconnect PBAP session from remote device.

Precondition:

None.

Command Parameters:

Device_Identifier: (Length: 1 Byte)

Value	Parameter Description
0xXX	Device Identifier

5.6.53.3 Pull_Phone_Book_Req

Command	Sub-Opcode	Command Parameters	Return Event
Pull_Phone_Book_Req	0x02	Device_Identifier	
		Repository	
		Object_Type	
		Supp_App_Para_Flag	
		Max_List_Count	
		Property_Selector	
		Format	
		List_Start_Offset	
		vCard_Selector	
		vCard_Selector_Operator	

Description:

This command is used to download Phone Book object from remote device.

Precondition:

None.

Command Parameters:

Device_Identifier: (Length: 1 Byte)

Value	Parameter Description
0xXX	Device Identifier

Repository: (Length: 1 Byte)

Value	Parameter Description
0x00	Telecom
0x01	SIM1

Object_Type: (Length: 1 Byte)

Value	Parameter Description
0x00	Phone book object
0x01	Incoming calls history object
0x02	Outgoing calls history object
0x03	Missed calls history object
0x04	Combined calls history object
0x05	Speed-Dial object
0x06	Favorite contacts object

Supp_App_Para_Flag: (Length: 2 Bytes)

Bit	Parameter Description
Bit 0	Property Selector 0: Property selector is invalid 1: Property selector is valid
Bit 1	Format_Flag 0: Format is invalid 1: Format is valid
Bit 2	List_Start Offset_Flag 0: List start offset is invalid 1: List start offset is valid
Bit 6	Reset new missed calls 0: Not reset 1: Reset missed call counter

.....continued	
Bit	Parameter Description
Bit 10	vCard Selector 0: vCard_Selector is invalid 1: vCard_Selector is valid Available if profile version is 1.2
Bit 12	vCard Selector Operator 0: vCard_Selector_Operator is invalid 1: vCard_Selector_Operator is valid Available if profile version is 1.2
Bit 14	Max_List_Count_Flag 0: Max_List_Count is invalid 1: Max_List_Count is valid

Max_List_Count: (Length: 2 Bytes)

Value	Parameter Description
0xFFFF	The maximum number of entries that PCE can handle

Property_Selector: (Length: 8 Bytes)

Value	Parameter Description
0xFFFFFFFF	Refer PB_Property_Selector_Table Bit = 1 indicates that the value shall be present if available

PB_Property_Selector_Table: (Length: 8 Bytes)

Byte 0	Parameter Description
Bit 0	vCard version
Bit 1	Formatted name
Bit 2	Structured presentation of name
Bit 3	Associated image or photo
Bit 4	Birthday
Bit 5	Delivery address
Bit 6	Delivery
Bit 7	Telephone number
Byte 1	Parameter Description
Bit 0	Email

.....continued

Byte 1	Parameter Description
Bit 1	Mailer
Bit 2	Time zone
Bit 3	Geographic position
Bit 4	Job title
Bit 5	Role within the organization
Bit 6	Organization logo
Bit 7	vCard of person representing

Byte 2	Parameter Description
Bit 0	Name of organization
Bit 1	Comments
Bit 2	Revision
Bit 3	Pronunciation of name
Bit 4	Uniform resource locator
Bit 5	Unique ID
Bit 6	Public encryption key
Bit 7	Nickname

Byte 3	Parameter Description
Bit 0	Categories
Bit 1	Product ID
Bit 2	Class information
Bit 3	String used for sorting operations
Bit 4	Time stamp
Bit 5	Reserved for future use
Bit 6	Reserved for future use
Bit 7	Reserved for future use

Byte 4	Parameter Description
Bit 0-6	Reserved for future use
Bit 7	Reserved for future use

Byte 5	Parameter Description
Bit 0- 7	Reserved for future use

Byte 6	Parameter Description
Bit 0-7	Reserved for future use

Byte 7	Parameter Description
Bit 0-7	Reserved for future use

Format: (Length: 1 Bytes)

Value	Parameter Description
0x00	vCard 2.1
0x01	vCard 3.0

List_Start_Offset: (Length: 2 Bytes)

Value	Parameter Description
0xXXXX	The offset of first entry

vCard_Selector: (Length: 8 Bytes)

Value	Parameter Description
0XXXXXXXX	<p>This parameter is used to filter for vCards that contain the requested vCard properties. Refer PB_Property_Selector_Table Use this parameter to receive only vCards in which the requested set of vCard properties is not null.</p> <p>Bit = 1 indicates that the property is requested</p> <p>Available if profile version is 1.2</p>

vCard_Selector_Operator: (Length: 1 Bytes)

Value	Parameter Description
0XXXXXXXX	<p>The parameter vCardSelectorOperator shall only be used in the request together with the parameter vCardSelector. The vCardSelectorOperator determines which logic shall be used when multiple bits of the vCard_Selector parameter are set. A bit value of 0 indicates that (OR) logic shall be used, a bit value of 1 indicates that AND logic shall be used.</p> <p>Available if profile version is 1.2</p>

5.6.53.4 Pull_Vcard_Listing_Req

Command	Sub-Opcode	Command Parameters	Return Event
Pull_Vcard_Listing_Req	0x03	Device_Identifier	
		Folder	
		Supp_App_Para_Flag	

.....continued			
Command	Sub-Opcode	Command Parameters	Return Event
		Max_List_Count	
		Order	
		Search_Property	
		List_Start_Offset	
		vCard_Selector	
		vCard_Selector_Operator	
		Search_Value_Length	
		Search_Value	

Description:

This command is used to retrieve a list of Phone Book entries from remote device.

Precondition:

None.

Command Parameters:

Device_Identifier: (Length: 1 Byte)

Value	Parameter Description
0xXX	Device Identifier

Folder: (Length: 1 Byte)

Value	Parameter Description
0x00	TELECOM
0x01	SIM1
0x02	PB
0x03	ICH
0x04	OCH
0x05	MCH
0x06	CCH
0x07	SPD
0x08	FAV

Supp_App_Para_Flag: (Length: 2 Bytes)

Bit	Parameter Description
Bit 0	N/A
Bit 1	N/A

.....continued	
Bit	Parameter Description
Bit 2	List_Start Offset_Flag
Bit 3	0: List start offset is invalid
Bit 4:	1: List start offset is valid
Bit 5:	Order_Flag
	0: Order is invalid
	1: Order is valid
	Search_Value_Flag
	0: Search_Value is invalid
	1: Search_Value is valid
	Search_Attribute_Flag
	0: Search_Attribute is invalid
	1: Search_Attribute is valid
Bit 6	Reset new missed calls
	0: Not reset
	1: Reset missed call counter
Bit 10	vCard Selector
	0: vCard_Selector is invalid
	1: vCard_Selector is valid
	Available if profile version is 1.2
Bit 12	vCard Selector Operator
	0: vCard_Selector_Operator is invalid
	1: vCard_Selector_Operator is valid
	Available if profile version is 1.2
Bit 14	Max_List_Count_Flag
	0: Max_List_Count is invalid
	1: Max_List_Count is valid

Max_List_Count: (Length: 2 Bytes)

Value	Parameter Description
0xFFFF	The maximum number of entries that PCE can handle

Order: (Length: 1 Byte)

Value	Parameter Description
0x00	Indexed order: The vCards are ordered by increasing handle order
0x01	Alphabetical order: The sorting operation should be based on the N attribute of the selected folder entries.

.....continued	
Value	Parameter Description
0x02	Phonetically ordered: The sorting algorithm should be based on the Sound attribute.

Search_Property (Length: 1 Byte)

Value	Parameter Description
0xXX	0x00: Name 0x01: Number 0x02: Sound

List_Start_Offset: (Length: 2 Bytes)

Value	Parameter Description
0XXXXX	The offset of first entry

vCard_Selector: (Length: 8 Bytes)

Value	Parameter Description
0XXXXXXXX	This parameter is used to filter for vCards that contain the requested vCard properties. Refer PB_Property_Selector_Table Use this parameter to receive only vCards in which the requested set of vCard properties is not null. Bit = 1 indicates that the property is requested Available if profile version is 1.2

vCard_Selector_Operator: (Length: 1 Byte)s

Value	Parameter Description
0XXXXXXXX	The parameter vCardSelectorOperator shall only be used in the request together with the parameter vCardSelector. The vCardSelectorOperator determines which logic shall be used when multiple bits of the vCard_Selector parameter are set. A bit value of 0 indicates that (OR) logic shall be used, a bit value of 1 indicates that AND logic shall be used. Available if profile version is 1.2

PB_Property_Selector_Table: (Length: 8 Bytes)

Byte 0	Parameter Description
Bit 0	vCard version
Bit 1	Formatted name
Bit 2	Structured presentation of name
Bit 3	Associated image or photo
Bit 4	Birthday
Bit 5	Delivery address

.....continued

Byte 0	Parameter Description
Bit 6	Delivery
Bit 7	Telephone number

Byte 1	Parameter Description
Bit 0	Email
Bit 1	Mailer
Bit 2	Time zone
Bit 3	Geographic position
Bit 4	Job title
Bit 5	Role within the organization
Bit 6	Organization logo
Bit 7	vCard of person representing

Byte 2	Parameter Description
Bit 0	Name of organization
Bit 1	Comments
Bit 2	Revision
Bit 3	Pronunciation of name
Bit 4	Uniform resource locator
Bit 5	Unique ID
Bit 6	Public encryption key
Bit 7	Nickname

Byte 3	Parameter Description
Bit 0	Categories
Bit 1	Product ID
Bit 2	Class information
Bit 3	String used for sorting operations
Bit 4	Time stamp
Bit 5	Reserved for future use
Bit 6	Reserved for future use
Bit 7	Reserved for future use

Byte 4	Parameter Description
Bit 0-6	Reserved for future use
Bit 7	Reserved for future use

Byte 5	Parameter Description
Bit 0- 7	Reserved for future use

Byte 6	Parameter Description
Bit 0-7	Reserved for future use

Byte 7	Parameter Description
Bit 0-7	Reserved for future use

Search_Value_Length (Length: 1 Byte)s

Value	Parameter Description
0xXX	Search value length

Search_Val Length: Search_Value_Length Bytes

Value	Parameter Description
0xXX	Search value

5.6.53.5 Pull_Vcard_Entry_Req

Command	Sub-Opcode	Command Parameters	Return Event
Pull_Vcard_Entry_Req	0x04	Device_Identifier	
		Option	
		Supp_App_Para_Flag	
		Property_Selector	
		Format	
		Entry_Name	

Description:

This command is used to retrieve a Phone Book entry from remote device.

Precondition:

None.

Command Parameters:

Device_Identifier: (Length: 1 Byte)

Value	Parameter Description
0xXX	Device Identifier

Option: (Length: 1 Byte)

Value	Parameter Description
0x00	Object name: *.vcf
0x01	Object name: X-BT-UID

Supp_App_Para_Flag: (Length: 2 Bytes)

Bit	Parameter Description
Bit 0	Filter_Flag 0: Filter is invalid 1: Filter is valid
Bit 1	Format_Flag 0: Format is invalid 1: Format is valid

Property_Selector: (Length: 8 Bytes)

Value	Parameter Description
0XXXXXXXX	Refer PB_Property_Selector_Table Bit = 1 indicates that the value shall be present if available

PB_Property_Selector_Table: (Length: 8 Bytes)

Byte 0	Parameter Description
Bit 0	vCard version
Bit 1	Formatted name
Bit 2	Structured presentation of name
Bit 3	Associated image or photo
Bit 4	Birthday
Bit 5	Delivery address
Bit 6	Delivery
Bit 7	Telephone number

Byte 1	Parameter Description
Bit 0	Email
Bit 1	Mailer

.....continued

Byte 1	Parameter Description
Bit 2	Time zone
Bit 3	Geographic position
Bit 4	Job title
Bit 5	Role within the organization
Bit 6	Organization logo
Bit 7	vCard of person representing

Byte 2	Parameter Description
Bit 0	Name of organization
Bit 1	Comments
Bit 2	Revision
Bit 3	Pronunciation of name
Bit 4	Uniform resource locator
Bit 5	Unique ID
Bit 6	Public encryption key
Bit 7	Nickname

Byte 3	Parameter Description
Bit 0	Categories
Bit 1	Product ID
Bit 2	Class information
Bit 3	String used for sorting operations
Bit 4	Time stamp
Bit 5	Reserved for future use
Bit 6	Reserved for future use
Bit 7	Reserved for future use

Byte 4	Parameter Description
Bit 0-6	Reserved for future use
Bit 7	Reserved for future use

Byte 5	Parameter Description
Bit 0- 7	Reserved for future use

Byte 6	Parameter Description
Bit 0-7	Reserved for future use

Byte 7	Parameter Description
Bit 0-7	Reserved for future use

Format: (Length: 1 Byte)

Value	Parameter Description
0x00	vCard 2.1
0x01	vCard 3.0

Entry_Name: (Length: xx Bytes)

Value	Parameter Description
0xXX	vCard Entry Name, without filename extension For example: "16.vcf", the value is: 31 36 "25.vcf", the value is: 32 35

5.6.53.6 Set_Phone_Book_Req

Command	Sub-Opcode	Command Parameters	Return Event
Pull_Phone_Bbook_Req	0x05	Device_Identifier	
		Action	
		Folder	

Description:

This command is used to set current folder in the virtual folder architecture.

Precondition:

None.

Command Parameters:

Device_Identifier: (Length: 1 Byte)

Value	Parameter Description
0xXX	Device Identifier

Action: (Length: 1 Byte)

Value	Parameter Description
0x00	Go back to root
0x01	Go down 1 level
0x02	Go up 1 level

Folder: (Length: 1 Byte)

Value	Parameter Description
0x00	TELECOM
0x01	SIM1
0x02	PB
0x03	ICH
0x04	OCH
0x05	MCH
0x06	CCH
0x07	SPD
0x08	FAV

5.6.53.7 Abort_Req

Command	Sub-Opcode	Command Parameters	Return Event
Abort_Req	0x06	Device_Identifier	

Description:

This command is used to abort request.

Precondition:

None.

Command Parameters:

Device_Identifier: (Length: 1 Byte)

Value	Parameter Description
0xXX	Device Identifier

5.6.54 AVRCP_Browsing_Cmd (0x41)

Command	Op Code	Command Parameters	Return Event
AVRCP_Browsing_Cmd	0x41	Sub_Opcode, Parameters	AVRCP_Browsing_Event

Description:

This command is used to trigger AVRCP browsing command to the remote device (TG role).

Precondition:

AVRCP link has been established.

Return error: (Length: 1 Byte)

Value	Description	Condition
0x01	Command disallow	No AVRCP connection exist

.....continued		
Value	Description	Condition
0x03	Parameter error	Incorrect parameter value
0x05	BTM memory full	OS heap memory is full

5.6.54.1 GetFolderItems

Command	Sub-Opcode	Command Parameters	Return Event
GetFolderItems	0x00	Data_Base_Index	AVRCP_Browsing_Event
		Scope	
		Start_Item	
		End_Item	
		Attribute_Count	
		Attribute_List	

Description:

This command is used to retrieve a listing of the contents of a folder.

Precondition:

AVRCP link has been established.

Command Parameters:

Data_Base_Index: (Length: 1 Byte)

Value	Parameter Description
0xXX	Linked device index

Scope (Length: 1 Byte)

Value	Parameter Description
0x00	Contains all available media players.
0x01	The virtual filesystem containing the media content of the browsed player.
0x02	The results of a search operation on the browsed player.
0x03	The Now Playing list (or queue) of the addressed player.

Start_Item (Length: 4 Byte)

Value	Parameter Description
0XXXXXXXX	The offset within the listing of the item, which should be the first returned item. The first element in the listing is at offset 0.

End_Item (Length: 4 Byte)

Value	Parameter Description
0xFFFFFFFF	The offset within the listing of the item which should be the final returned item.

Attribute_Count (Length: 1 Byte)

Value	Parameter Description
0x00	All attributes are requested. There is no following Attribute List.
0x01-0xFE	The following Attribute List contains this number of attributes.
0xFF	No attributes are requested. There is no following Attribute List.

Attribute_List (Length: N Byte)

Value	Parameter Description
0xFFFFFFFF...	Attributes which are requested to be returned for each item returned. One attribute is 4 bytes. Therefore, the length of attribute list will be 4 * Attribute_Count bytes.

Value	Parameter Description
0x00000001	Title
0x00000002	Artist name
0x00000003	Album name
0x00000004	Track number
0x00000005	Total numbers of tracks
0x00000006	Genre
0x00000007	Playing time
0x00000008	Default cover art
0x00000009~ 0xFFFFFFFF	Reserved for future used

5.6.54.2 GetTotalNumberOfItems

Command	Sub-Opcode	Command Parameters	Return Event
GetTotalNumberOfItems	0x01	Data_Base_Index	AVRCP_Browsing_Event
		Scope	

Description:

This command is used to retrieve the number of items in a folder prior to calling GetFolderItems to retrieve a listing of the contents of a folder.

Precondition:

AVRCP link has been established.

Command Parameters:

Data_Base_Index: (Length: 1 Byte)

Value	Parameter Description
0xXX	Linked device index

Scope (Length: 1 Byte)

Value	Parameter Description
0x00	Contains all available media players.
0x01	The virtual file system containing the media content of the browsed player.
0x02	The results of a search operation on the browsed player.
0x03	The Now Playing list (or queue) of the addressed player.

5.6.54.3 SetAddressedPlayer

Command	Sub-Opcode	Command Parameters	Return Event
SetAddressedPlayer	0x02	Data_Base_Index	AVRCP_Browsing_Event
		PlayerId	

Description:

This command is used to inform the TG of which media player the CT wishes to control.

Precondition:

AVRCP link is established.

Command Parameters:

Data_Base_Index: (Length: 1 Byte)

Value	Parameter Description
0xXX	Linked device index

PlayerId (Length: 2 Byte)

Value	Parameter Description
0XXXXX	Unique media player Id

5.6.54.4 SetBrowsedPlayer

Command	Sub-Opcode	Command Parameters	Return Event
SetBrowsedPlayer	0x03	Data_Base_Index	AVRCP_Browsing_Event
		PlayerId	

Description:

This command is used to control to which player browsing commands should be routed.

Precondition:

AVRCP link is established.

Command Parameters:

Data_Base_Index: (Length: 1 Byte)

Value	Parameter Description
0xXX	Linked device index

PlayerId (Length: 2 Byte)

Value	Parameter Description
0XXXXX	Unique media player Id

5.6.54.5 ChangePath

Command	Sub-Opcode	Command Parameters	Return Event
ChangePath	0x04	Data_Base_Index	AVRCP_Browsing_Event
		UIDCounter	
		Direction	
		FolderUID	

Description:

This command is used to navigate the virtual filesystem.

Precondition:

AVRCP link is established.

Command Parameters:

Data_Base_Index: (Length: 1 Byte)

Value	Parameter Description
0xXX	Linked device index

UIDCounter (Length: 2 Byte)

Value	Parameter Description
0XXXXX	The UID counter

Direction (Length: 1 Byte)

Value	Parameter Description
0x00	Folder up
0x01	Folder down

FolderUID (Length: 8 Byte)

Value	Parameter Description
0xFFFFFFFFFFFFFFFF	The UID of the folder to navigate to. This may be retrieved via a GetFolderItems command. If the navigation command is Folder Up, then this field is reserved (Set as 0).

5.6.54.6 GetItemAttributes

Command	Sub-Opcode	Command Parameters	Return Event
GetItemAttributes	0x05	Data_Base_Index	AVRCP_Browsing_Event
		Scope	
		UID	
		UIDCounter	
		Attributes_Num	
		AttributeID_List	

Description:

This command is used to retrieve the metadata attributes for a particular media element item or folder item.

Precondition:

AVRCP link is established.

Command Parameters:

Data_Base_Index: (Length: 1 Byte)

Value	Parameter Description
0xXX	Linked device index

Scope (Length: 1 Byte)

Value	Parameter Description
0x00	Contains all available media players.
0x01	The virtual filesystem containing the media content of the browsed player.
0x02	The results of a search operation on the browsed player.
0x03	The Now Playing list (or queue) of the addressed player.

UID (Length: 8 Byte)

Value	Parameter Description
0xFFFFFFFFFFFFFFFF	The UID of the media element item or folder item to return the attributes

UIDCounter (Length: 2 Byte)

Value	Parameter Description
0XXXXX	The UID Counter

Attributes_Num (Length: 1 Byte)

Value	Parameter Description
0xXX	The number of attribute IDs in the following Attribute ID list. If this value is zero, then all attributes are requested.

AttributeID_List (Length: N Byte)

Value	Parameter Description
0XXXXXXXX...	Attributes which are requested to be returned for each item returned. One attribute is 4 bytes. Therefore, the length of attribute list will be 4 * Attribute_Count bytes.

5.6.54.7 Search

Command	Sub-Opcode	Command Parameters	Return Event
Search	0x06	Data_Base_Index	AVRCP_Browsing_Event
		Length	
		SearchString	

Description:

This command is used to perform search functionality.

Precondition:

AVRCP link is established.

Command Parameters:

Data_Base_Index: (Length: 1 Byte)

Value	Parameter Description
0xXX	Linked device index

Length (Length: 2 Byte)

Value	Parameter Description
0XXXXX	The length of the search string in octets.

SearchString (Length: N Byte)

Value	Parameter Description
0XXXXX...	The string to search on in the specified character set.

5.6.54.8 PlayItem

Command	Sub-Opcode	Command Parameters	Return Event
PlayItem	0x07	Data_Base_Index	AVRCP_Browsing_Event
		Scope	

.....continued			
Command	Sub-Opcode	Command Parameters	Return Event
		UID	
		UIDCounter	

Description:

This command is used to start playing an item indicated by the UID.

Precondition:

AVRCP link is established.

Command Parameters:

Data_Base_Index: (Length: 1 Byte)

Value	Parameter Description
0xXX	Linked device index

Scope (Length: 1 Byte)

Value	Parameter Description
0x00	Contains all available media players.
0x01	The virtual file system containing the media content of the browsed player.
0x02	The results of a search operation on the browsed player.
0x03	The Now Playing list (or queue) of the addressed player.

UID (Length: 8 Byte)

Value	Parameter Description
0XXXXXXXXXXXXXXXXXX	The UID of the media element item or folder item.

UIDCounter (Length: 2 Byte)

Value	Parameter Description
0XXXXX	The UID counter

5.6.54.9 AddToNowPlaying

Command	Sub-Opcode	Command Parameters	Return Event
AddToNowPlaying	0x08	Data_Base_Index	AVRCP_Browsing_Event
		Scope	
		UID	
		UIDCounter	

Description:

This command is used to add an item indicated by the UID to the Now Playing queue.

Precondition:

AVRCP link is established.

Command Parameters:

Data_Base_Index: (Length: 1 Byte)

Value	Parameter Description
0xXX	Linked device index

Scope (Length: 1 Byte)

Value	Parameter Description
0x00	Contains all available media players.
0x01	The virtual file system containing the media content of the browsed player.
0x02	The results of a search operation on the browsed player.
0x03	The Now Playing list (or queue) of the addressed player.

UID (Length: 8 Byte)

Value	Parameter Description
0XXXXXXXXXXXXXXXXXX	The UID of the media element item or folder item.

UIDCounter (Length: 2 Byte)

Value	Parameter Description
0XXXXX	The UID counter

5.6.55 MMI_Action UART Command (0x02)

Command	Op Code	Command Parameters	Return Event
MMI_Action	0x02	data_base_index, action	

Description:

MCU can send proper command to complete different kinds of action.

Command Parameters:

data_base_index: Length: 1 Byte

Value	Parameter Description
0xNN	Database index of dedicate HF device bit0-2: data base index bit3-5: RFCOMM index if two SPP feature is enabled

Value	Parameter Description
0x01	Add/remove SCO link
0x02	Force end active call (Deprecated)
0x04	Accept an incoming call

.....continued	
Value	Parameter Description
0x05	Reject an incoming call
0x06	End call/ transfer audio to phone
0x07	Toggle microphone on/off
0x08	Mute microphone
0x09	Active microphone
0x0A	Voice dial
0x0B	Cancel voice dial
0x0C	Last number redial
0x0D	Set the active call on hold and active the hold call
0x0E	Switch voice between phone and headset
0x0F	Query call list information(CLCC)
0x10	Three way call
0x11	Release the waiting call or on hold call
0x12	Accept the waiting call or active the on hold call and release the active call
0x16	Initiate HF connection (Deprecated)
0x17	Disconnect HF link
0x18	Enable RX noise reduction when SCO ready (Deprecated)
0x19	Disable RX noise reduction when SCO is ready (Deprecated)
0x1A	Switch RX noise reduction when SCO is ready (Deprecated)
0x1B	Enable TX noise reduction when SCO is ready (Deprecated)
0x1C	Disable TX noise reduction when SCO is ready (Deprecated)
0x1D	Switch TX noise reduction when SCO is ready (Deprecated)
0x1E	Enable AEC when SCO is ready
0x1F	Disable AEC when SCO is ready
0x20	Switch AEC enable/disable when SCO is ready
0x21	Enable AEC RX noise reduction when SCO is ready
0x22	Disable AEC RX noise reduction when SCO is ready
0x23	Switch AEC RX noise reduction when SCO is ready
0x24	Increase microphone gain
0x25	Decrease microphone gain
0x26	Switch primary HF device and secondary HF device role

.....continued	
Value	Parameter Description
0x30	Increase speaker gain (Deprecated)
0x31	Decrease speaker gain (Deprecated)
0x32	Play/Pause music (Deprecated)
0x33	Stop music (Deprecated)
0x34	Next song (Deprecated)
0x35	Previous song (Deprecated)
0x36	Fast forward (Deprecated)
0x37	Rewind (Deprecated)
0x38	EQ mode up (Deprecated)
0x39	EQ mode down (Deprecated)
0x3B	Disconnect A2DP link
0x3C	Next audio effect
0x3D	Previous audio effect
0x3F	Report current EQ mode
0x40	Report current audio effect status
0x50	Enter pairing mode (from power off state) (Deprecated)
0x51	Power on button press
0x52	Power on button release
0x53	Power off button press
0x54	Power off button release
0x55	Reverse panel
0x56	Reset some EEPROM setting to default setting
0x57	Force speaker gain toggle
0x58	Toggle button indication
0x5D	Fast enter pairing mode (from non-off mode)
0x5E	Switch power OFF
0x5F	Disable LED
0x60	Toggle buzzer
0x61	Disable buzzer
0x62	Enable buzzer
0x63	Change tone set (SPK module support two sets of tone)

.....continued	
Value	Parameter Description
0x64	Retrieve phonebook
0x65	Retrieve MCH
0x66	Retrieve ICH
0x67	Retrieve OCH
0x68	Retrieve CCH
0x69	Cancel access PBAP
0x6A	Indicate battery status
0x6B	Exit pairing mode
0xE0	Trigger NSPK Master
0xE1	Trigger NSPK Slave
0xE2	NSPK one key connect/disconnect
0xE3	Cancel NSPK creation
0xE4	Terminate NSPK link
0xE5	Terminate / Cancel NSPK connection
0xE6	NSPK Master enter Aux-in 44.1K PCM Encoder mode
0xE7	NSPK Master enter Aux-in 48K PCM Encoder mode
0xE8	NSPK Master exit Aux-in PCM Encoder mode
0xE9	NSPK Master enter Aux-in SBC Encoder mode
0xEB	NSPK dynamic creation
0xEC	NSPK switch channel
0xED	NSPK power off all speakers
0xEE	NSPK AFH SBCENCODING AUDIOSYNC
0xF4	NSPK_ENTER_NSPK_MODE
0xF5	NSPK_ENTER_BROADCAST_MODE
0xF6	NSPK_ADD_THIRD_SPK
0xF7	NSPK_SOUND_SYNCHRONIZATION
0xF8	NSPK_CSB_CONNECTED_MODE_SWITCH
0xF9	NSPK back to last mode

5.6.55.1 Action 0x01: Add / Remove SCO Link

Value	Parameter Description
0x01	Add/remove SCO link

Return error: Length: 1 Byte

Value	Description	Condition
0x01	Command disallow	No HF connection

Description:

This action is used to create a SCO link if the ACL link exists and no SCO connection. It also can disconnect the SCO link if the SCO link exists.

5.6.55.2 Action 0x04: Accept an Incoming Call

Value	Parameter Description
0x04	Accept an incoming call

Return error: (Length: 1 Byte)

Value	Description	Condition
0x01	Command disallow	No HF connection No incoming call on going

Description:

This action is used to answer the incoming call.

5.6.55.3 Action 0x05: Reject an Incoming Call

Value	Parameter Description
0x05	Reject an incoming call

Return Error: (Length: 1 Byte)

Value	Description	Condition
0x01	Command disallow	No HF connection No incoming call on going

Description:

This action is used to reject the incoming call.

5.6.55.4 Action 0x06: End Call/Transfer Audio to Phone

Value	Parameter Description
0x06	<ol style="list-style-type: none"> 1. End call if SCO exist. 2. Voice transfers to headset if SCO does not exist.

Return Error: (Length: 1 Byte)

Value	Description	Condition
0x01	Command disallow	No HF connection No Call active No outgoing call on going

Description:

This action is used to hang-up the active call if outgoing call ongoing or SCO exist.

It also can transfer the voice to headset if SCO does not exist.

If device supports three-way call and there is on hold or wait call, this action can disconnect all the active call and keep the on hold or wait call.

5.6.55.5 Action 0x07: Toggle Microphone ON/OFF

Value	Parameter Description
0x07	1. Mutes microphone if microphone is not in mute 2. Activates microphone if microphone is in mute

Return error: (Length: 1 Byte)

Value	Description	Condition
0x01	Command disallow	No HF connection No Call active No SCO connection

Description:

This action is used to mute or activate microphone while CALL active or SCO exists.

5.6.55.6 Action 0x08: Mute Microphone

Value	Parameter Description
0x08	Mutes microphone

Return Error: (Length: 1 Byte)

Value	Description	Condition
0x01	Command disallow	No HF connection Call is not active Outgoing call is not on going

Return Error: (Length: 1 Byte)

Value	Description	Condition
0x01	Command disallow	No HF connection No Call is active No SCO connection Microphone is in mute

Description:

This action is used to mute microphone while CALL active or SCO exists.

5.6.55.7 Action 0x09: Active Microphone

Value	Parameter Description
0x09	Un-mutes microphone

Return Error: (Length: 1 Byte)

Value	Description	Condition
0x01	Command disallow	No HF connection Call is not active No SCO connection Microphone is unmute

Description:

This action is used to unmute microphone while CALL is active or SCO exists.

5.6.55.8 Action 0x0A: Voice Dial

Value	Parameter Description
0x0A	Voice dial

Return Error: (Length: 1 Byte)

Value	Description	Condition
0x01	Command disallow	Voice recognition is not supported Already has active call

Description:

This action is used to activate voice dial if HF is connected. If there is no HF connection, it initiates the HF connection and activates the voice recognition application (for example, Siri®)

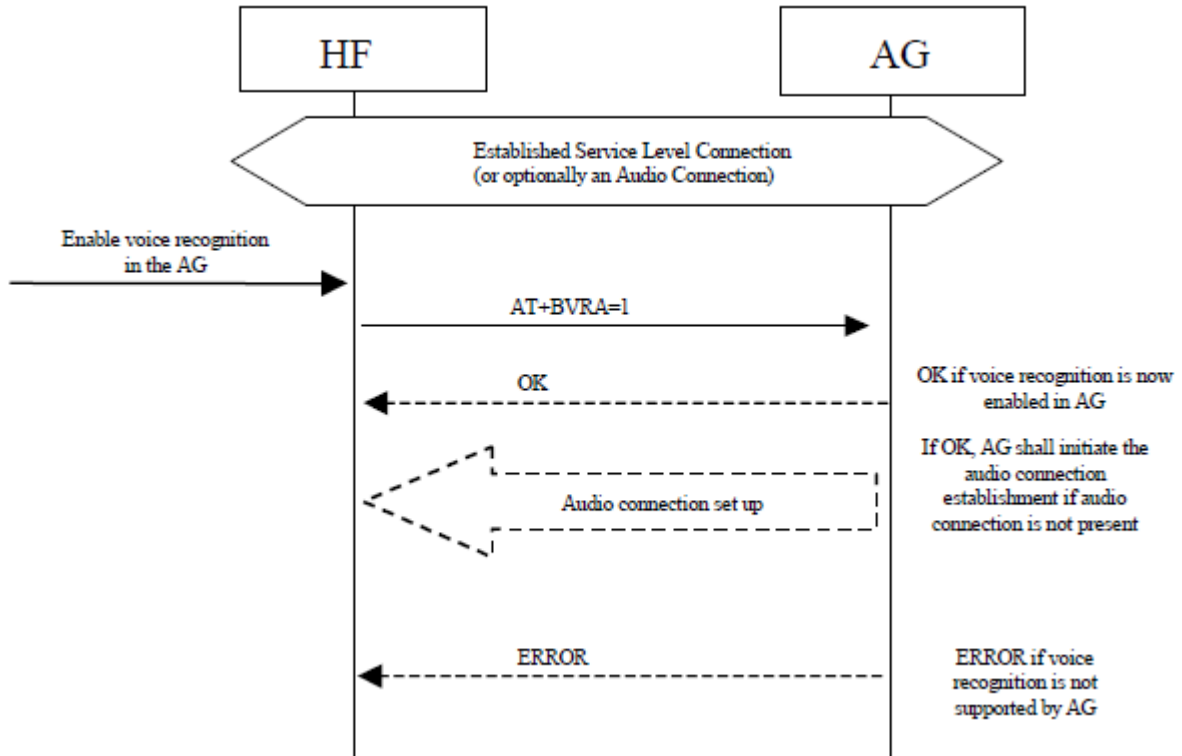

5.6.55.9 Action 0x0B: Cancel Voice Dial

Value	Parameter Description
0x0B	Cancels voice dial

Return Error: (Length: 1 Byte)

Value	Description	Condition
0x01	Command disallow	No HF connection No voice call No activation of ongoing voice call

Description:

This action is used to deactivate voice dial if HF is connected.

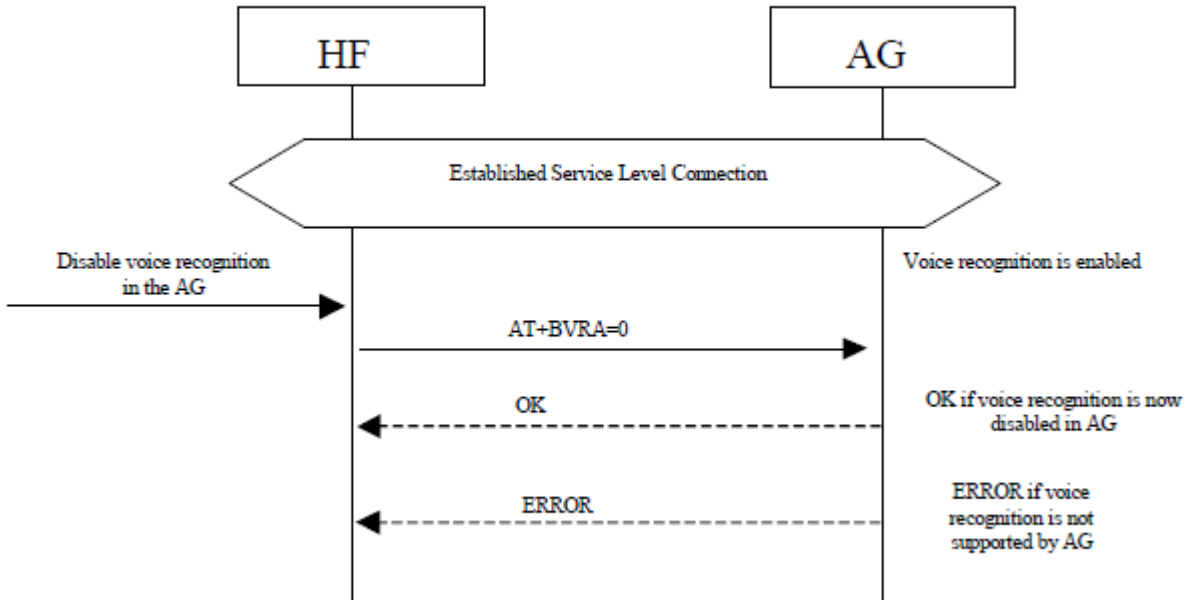

5.6.55.10 Action 0x0C: Last Number Redial

Value	Parameter Description
0x0C	Redial the last number

Description:

This action is used to redial the last number if HF is connected. If there is no HF connection, it initiates the HF connection and activates the last number redial.

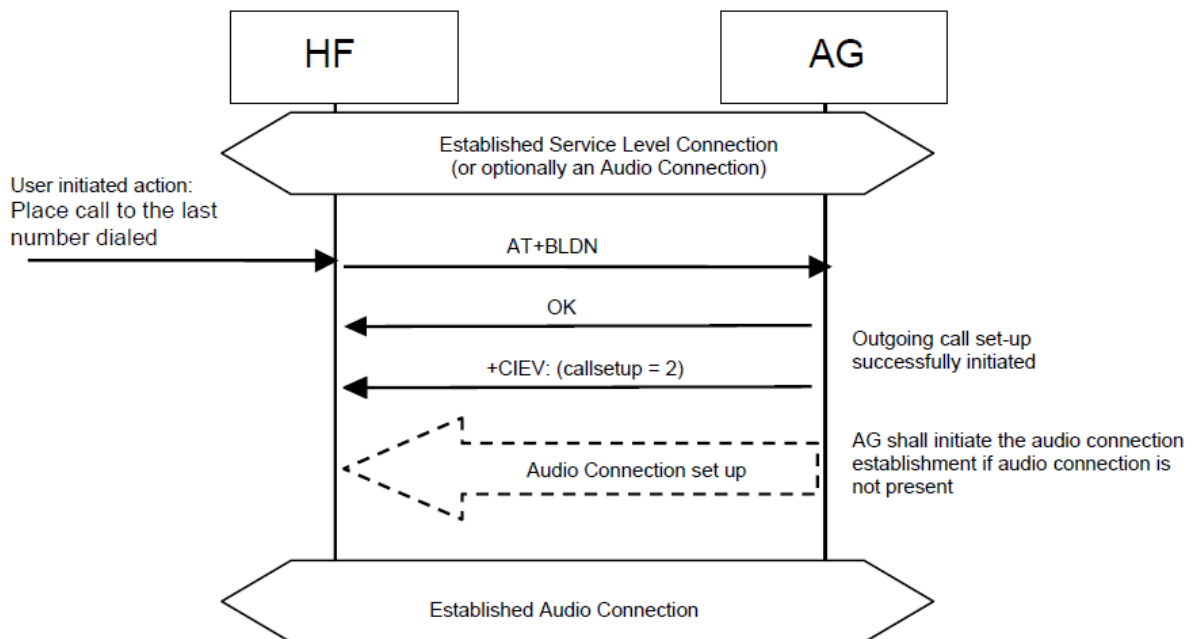

5.6.55.11 Action 0x0D: Set the Active Call on Hold and Activate the Hold Call

Value	Parameter Description
0x0D	Set the active call on hold and activate the hold call

Return Error: (Length: 1 Byte)

Value	Description	Condition
0x01	Command disallow	No HF connection Does not support three-way calling No active call while call is on hold and outgoing call is ongoing

Description:

This action is used to swap the active/hold call position. If cell phone does not support three-way calling, it hangs up the call.

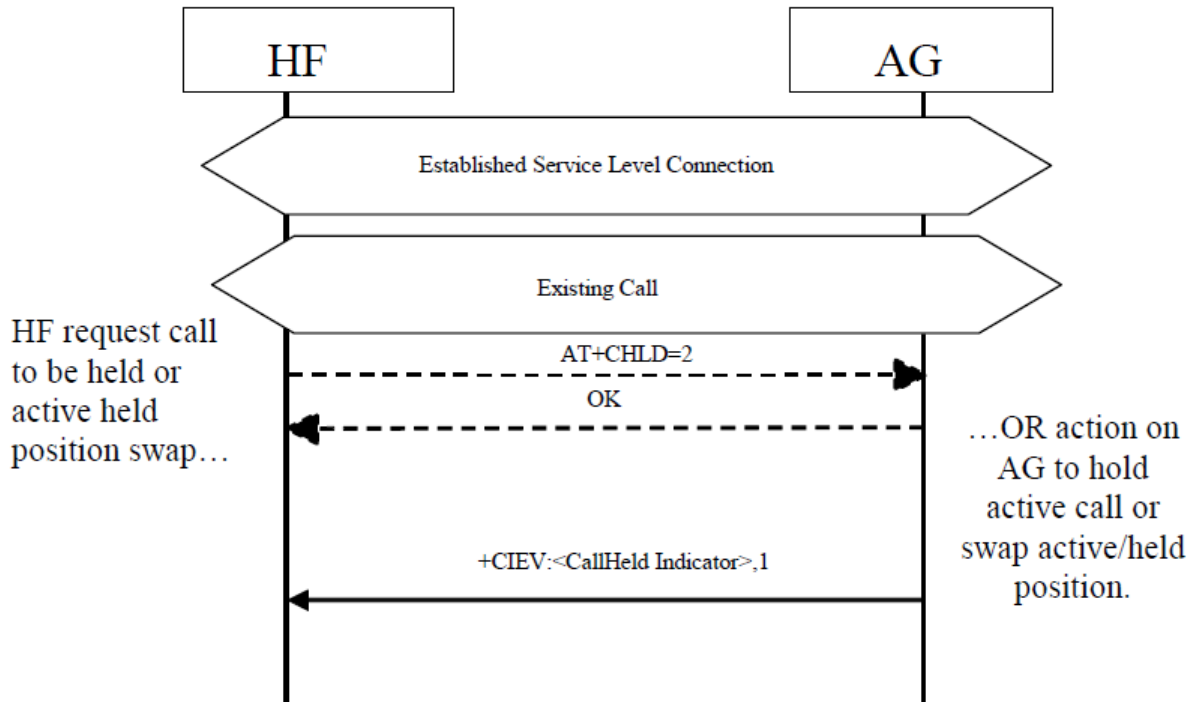

5.6.55.12 Action 0x0E: Switch Voice Between Phone and Headset

Value	Parameter Description
0x0E	Voice transfer

Return error: (Length: 1 Byte)

Value	Description	Condition
0x01	Command disallow	No SCO connection existing. No active call. No outgoing call ongoing.

Description:

This action is used to switch voice between phone and headset. If HF is not connected, SPK creates the HF connection.

5.6.55.13 Action 0x0F: Query Call List Information (CLCC)

Value	Parameter Description
0x0F	Trigger SPK module to query call list information

Return error: Length: 1 Byte

Value	Description	Condition
0x01	Command disallow	No HF connection

Description:

The HF shall execute this procedure to query the list of current calls in AG.

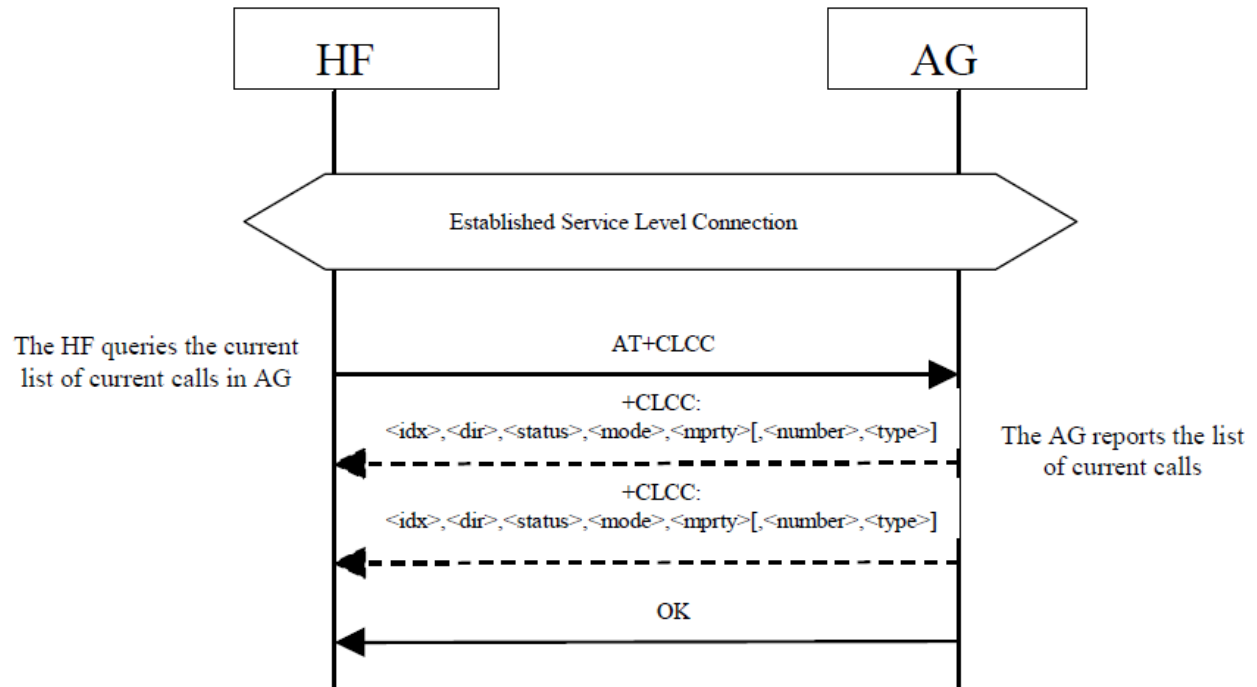

[+CLCC:<id1>,<dir>,<stat>,<mode>,<mpty>[,<number>,<type>[,<alpha>]]]<CR><LF>
 +CLCC:<id2>,<dir>,<stat>,<mode>,<mpty>[,<number>,<type>[,<alpha>]] [...]]

Value	Description
<idx>	Call identification number
<dir>	

.....continued	
Value	Description
0	Mobile Originated (MO) call
1	Mobile Originated (MT) call
<state>	State of the call
0	ACTIVE
1	HELD
2	Dialing (MO)
3	Alerting (MO)
4	Incoming (MT)
5	Waiting (MT)
<mode>	
0	Voice
1	Data
2	Fax
3	Voice followed by data, voice mode
4	Alternating voice/data, voice mode
5	Alternating voice/fax, voice mode
6	Voice followed by data, data mode
7	Alternating voice/data, data mode
8	Alternating voice/fax, fax mode
9	Unknown
<mpty>	
0	Call is not one of multiparty (conference) call parties
1	Call is one of multiparty (conference) call parties

5.6.55.14 Action 0x10: Three Way Call

Value	Parameter Description
0x10	Three-way call

Return Error: (Length: 1 Byte)

Value	Description	Condition
0x01	Command disallow	No HF connection

Description:

This action is used to add a hold call into the conference if the device/operator supports three-way call feature.

5.6.55.15 Action 0x11: Release the Waiting Call or On Hold Call

Value	Parameter Description
0x11	Releases the waiting call or on hold call

Return Error: (Length: 1 Byte)

Value	Description	Condition
0x01	Command disallow	No HF connection

Description:

This action is used to release all held call.

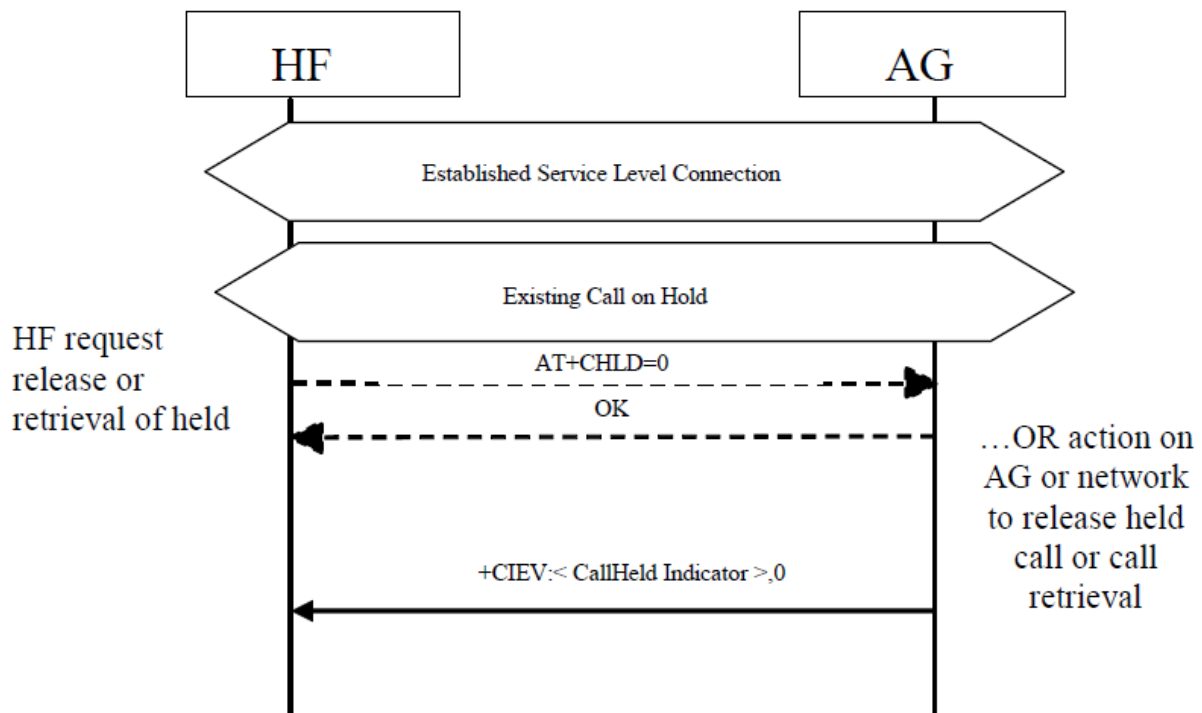

5.6.55.16 Action 0x12: Accept the Waiting Call or Activate the On Hold Call and Release the Active Call

Value	Parameter Description
0x12	Accepts the waiting call or activates the on hold call and releases the active call

Return Error: (Length: 1 Byte)

Value	Description	Condition
0x01	Command disallow	No HF connection

Description:

This action is used to release active call and accept the waiting/hold call if the device supports three-way calls.

5.6.55.17 Action 0x17: Disconnect HF Link

Value	Parameter Description
0x17	Disconnects HF link

Return Error: (Length: 1 Byte)

Value	Description	Condition
0x01	Command disallow	No HF connection No ACL connection and no HF/HS connected profile

Description:

This action is used to disconnect HF connection.

5.6.55.18 Action 0x24: Increase Microphone Gain

Value	Parameter Description
0x24	Increase the microphone gain

Return Error: (Length: 1 Byte)

Value	Description	Condition
0x01	Command disallow	No HF connection

Description:

This action is used to increase the microphone gain.

5.6.55.19 Action 0x25: Decrease Microphone Gain

Value	Parameter Description
0x25	Decrease the microphone gain

Return Error: (Length: 1 Byte)

Value	Description	Condition
0x01	Command disallow	No HF connection

Description:

This action is used to reduce the microphone gain.

5.6.55.20 Action 0x26: Switch Primary HF Device and Secondary HF Device Role

Value	Parameter Description
0x26	Switches primary HF device and secondary HF device role

Return Error: (Length: 1 Byte)

Value	Description	Condition
0x01	Command disallow	No HF connection

Description:

This action is used to switch the primary/secondary HF device role when SPK supports multiple connections.

5.6.55.21 Action 0x3B: Disconnect A2DP Link

Value	Parameter Description
0x3B	Disconnects A2DP link

Return Error: (Length: 1 Byte)

Value	Description	Condition
0x01	Command disallow	No ACL connection A2DP is not connected

Description:

This action is used to disconnect A2DP connection.

5.6.55.22 Action 0x3C: Next Audio Effect

Value	Parameter Description
0x3C	Next audio effect

Description:

This action is used to switch to next audio effect.

5.6.55.23 Action 0x3D: Previous Audio Effect

Value	Parameter Description
0x3D	Previous audio effect

Description:

This action is used to switch to previous audio effect.

5.6.55.24 Action 0x3F: Report Current EQ Mode

Value	Parameter Description
0x3F	Reports current EQ mode

Return Error: (Length: 1 Byte)

Value	Description	Condition
0x01	Command disallow	DSP does not support EQ mode

Description:

This action is used to report current EQ mode. If embedded mode is enabled, current EQ status is reported via SPP connection.

5.6.55.25 Action 0x40: Report Current Audio Effect Status

Value	Parameter Description
0x40	Reports current audio effect status

Description:

This action is used to report current audio effect status. If the embedded mode enabled, current audio effect status is reported via SPP connection.

5.6.55.26 Action 0x51: Power On Button Oress

Value	Parameter Description
0x51	Presses the Power on button

Description:

This action is used to press the power on button.

5.6.55.27 Action 0x52: Power On Button Release

Value	Parameter Description
0x52	Releases the Power on button

Description:

This action is used to release the power on button.

5.6.55.28 Action 0x53: Power Off Button Press

Value	Parameter Description
0x53	Presses the Power off button

Description:

This action is used to press the power off button.

5.6.55.29 Action 0x54: Power Off Button Release

Value	Parameter Description
0x54	Releases the Power off button

Description:

This action is used to release power off button.

5.6.55.30 Action 0x55: Reverse Panel

Value	Parameter Description
0x55	Reverse panel

Description:

This action is used to release reverse panel.

5.6.55.31 Action 0x56: Reset some EEPROM Setting to Default Value

Value	Parameter Description
0x56	Reset some of the EEPROM settings to default value

Description:

This action is used to reset some of the EEPROM setting to default value.

Device_List_Table	Erase the device table: 0x00
linked_priority	Erase the linked priority: 0x00
mic_gain_level	Microphone gain: 0XDD
device_speaker_gain	Speaker gain: 0x99
device_absolute_volume	Absolute volume: 0x99
app_function_status	buzzer status: OFF BT_STABDBY_MODE_BIT: keep the speaker connectable in power off state. disabled VOL_CTRL_DIRECT_BIT: circular volume control direction. 0: volume up when volume control
hf_device_index	Record HF primary device index: 0xFF
a2dp_device_index	Record A2DP device: 0xFF
line_in_gain_level	Line-in gain: 0x99
CSB_DIAC	The access code for dedicate CSB pairing: 0x00000000
CSB_Trigger_Sync_Role_Setting	Sync role setting: 0x00
NSPK_channel	nSPK channel: 0x21

5.6.55.32 Action 0x57: Force Speaker Gain Toggle

Value	Parameter Description
0x57	Forces speaker gain to toggle

Return Error: (Length: 1 Byte)

Value	Description	Condition
0x01	Command disallow	No Call exist

Description:

This action is used to release power off button.

5.6.55.33 Action 0x58: Toggle Button Indication

Value	Parameter Description
0x58	Toggle button indication

Description:

This action is used to indicate toggle button and depends on the settings of EEPROM output_indication_table.

output_indication_table[0] : indication GPIO0

output_indication_table[1] : indication GPIO1

5.6.55.34 Action 0x5D: Fast Enter Pairing Mode (from Non-off Mode)

Value	Parameter Description
0x5D	Enters pairing mode faster (from non-off mode)

data_base_index: (Length: 1 Byte)

Value	Parameter Description
0x00	BTM generates tone when enters the pairing mode
Others	BTM does not generate tone when enters the pairing mode

Return Error: (Length: 1 Byte)

Value	Description	Condition
0x01	Command disallow	SPK is in OFF state

Description:

This action is used to enter the pairing mode from the non-off mode.

5.6.55.35 Action 0x5E: Switch Power Off

Value	Parameter Description
0x5E	Switches the power off process

Description:

This action is used to execute the power off process. If nSPK is connected, this action is used to disconnect the remote nSPK and MCU receive EVENT [BTM_Utility_Rsp](#) (0x1B) with action_type 0x05.

After receiving the event, MCU can send MMI_Action 0x53, 0x54 to power off the current SPK.

If it is a standalone SPK, this action executes the power off directly.

5.6.55.36 Action 0x5F: Disable LED

Value	Parameter Description
0x5F	Disables LED

Description:

This action is used to disable LED.

5.6.55.37 Action 0x60: Toggle Buzzer

Value	Parameter Description
0x60	Toggles buzzer

Description:

This action is used to toggle buzzer if Buzzer function is implemented.

5.6.55.38 Action 0x61: Disable Buzzer

Value	Parameter Description
0x61	Disables buzzer

Description:

This action is used to disable buzzer if Buzzer function is implemented.

5.6.55.39 Action 0x62: Enable Buzzer

Value	Parameter Description
0x62	Enables buzzer

Description:

This action is used to enable buzzer if Buzzer function is implemented.

5.6.55.40 Action 0x63: Switch to Next Support Ringtone Language Set

Value	Parameter Description
0x63	Switches to next support ringtone language set.

Description:

This action is used to switch to next support ringtone language set.

5.6.55.41 Action 0x64 to 0x69: Retrieve Phonebook Profile Information

Value	Parameter Description
0x64	Retrieve phonebook
0x65	Retrieve MCH (Missed Call History)
0x66	Retrieve ICH (Incoming\Received Call History)
0x67	Retrieve OCH (Outgoing\Dialed Call History)
0x68	Retrieve CCH (All Call History)
0x69	Cancel access PBAP

Description:

This action is used to access phone book if it supports PBAP. These actions are only supported in some firmwares.

5.6.55.42 Action 0x6A: Indicate Battery Status

Value	Parameter Description
0x6A	Indicate battery status

Description:

This action is used to indicate battery (high, medium, low) status via voice prompt if device supports voice prompt report battery status feature or LED indication.

5.6.55.43 Action 0x6B: Exit Pairing Mode

Value	Parameter Description
0x6B	Exits the pairing mode

Return Error: (Length: 1 Byte)

Value	Description	Condition
0x01	Command disallow	SPK is in the paring mode/SPP connection exists SPK has A2DP connection/HF HS connection if device supports the social mode

Description:

This action is used to exit the pairing mode.

5.6.55.44 Action 0xE0: Trigger NSPK Master

Value	Parameter Description
0xE0	Triggers NSPK master

Return Error: (Length: 1 Byte)

Value	Description	Condition
0x01	Command disallow	Call is in active state Line-in/Aux-in CSB mode is disabled

Description:

This action is used to enter the NSPK master mode.

5.6.55.45 Action 0xE1: Trigger NSPK Slave

Value	Parameter Description
0xE1	Triggers NSPK Slave

Return Error: (Length: 1 Byte)

Value	Description	Condition
0x01	Command disallow	Call active Line-in/Aux-in CSB mode is disabled

Description:

This action is used to enter the NSPK Slave mode.

5.6.55.46 Action 0xE2: Trigger NSPK Slave

Value	Parameter Description
0xE2	Triggers NSPK slave

Return Error: (Length: 1 Byte)

Value	Description	Condition
0x01	Command disallow	Call active Line-in/Aux-in CSB mode is disabled CSB state is not in "Connecting", "Connected" or "Add 3 rd SPK" state

Description:

This action is used for NSPK one key connect/disconnect.

5.6.55.47 Action 0xE3: Cancel NSPK Create Connection

Value	Parameter Description
0xE3	Cancels NSPK create connection

Return Error: (Length: 1 Byte)

Value	Description	Condition
0x01	Command disallow	CSB state is not in "Connecting", "Connected" or "Add 3 rd SPK" state

Description:

This action is used to cancel the NSPK create connection.

5.6.55.48 Action 0xE4: Terminate NSPK Link

Value	Parameter Description
0xE4	Terminates the NSPK link

Return Error: (Length: 1 Byte)

Value	Description	Condition
0x01	Command disallow	CSB state is not in "Connected" or "Add 3 rd SPK" state

Description:

This action is used to terminate the NSPK link.

5.6.55.49 Action 0xE5: Terminate / Cancel NSPK Connection

Value	Parameter Description
0xE5	Terminate/cancel the NSPK connection

Return Error: (Length: 1 Byte)

Value	Description	Condition
0x01	Command disallow	CSB state is not is "Connecting", "Connected", "Wait to create CSB link" or "Add 3 rd SPK" state

Description:

This action is used to terminate/cancel the NSPK connection.

5.6.55.50 Action 0xE6: NSPK Master Enters Aux-in 44.1K PCM Encoder Mode

Value	Parameter Description
0xE6	NSPK Master enters the Aux-in 44.1K PCM Encoder mode

Return Error: (Length: 1 Byte)

Value	Description	Condition
0x01	Command disallow	SPK acts as slave

Description:

This action is used for NSPK master to enter the AUX-IN 44.1K PCM encoder mode.

5.6.55.51 Action 0xE7: NSPK Master Enters Aux-in 48K PCM Encoder Mode

Value	Parameter Description
0xE7	NSPK Master enters the Aux-in 48K PCM Encoder mode

Return Error: (Length: 1 Byte)

Value	Description	Condition
0x01	Command disallow	SPK acts as slave

Description:

This action is used for NSPK master to enter the AUX-IN 48K PCM encoder mode.

5.6.55.52 Action 0xE8: NSPK Master Exits Aux-in PCM Encoder Mode

Value	Parameter Description
0xE8	NSPK Master exits the Aux-in PCM Encoder mode

Description:

This action is used for NSPK master to exit the AUX-IN PCM encoder mode.

5.6.55.53 Action 0xE9: NSPK Master Enters Aux-in SBC Encoder Mode

Value	Parameter Description
0xE9	NSPK Master enters the Aux-in SBC Encoder mode

Return Error: (Length: 1 Byte)

Value	Description	Condition
0x01	Command disallow	SPK acts as slave

Description:

This action is used for NSPK master to enter the AUX-IN SBC encoder mode.

5.6.55.54 Action 0xEB: NSPK Dynamic Creation

Value	Parameter Description
0xEB	NSPK dynamic creation

Return Error: (Length: 1 Byte)

Value	Description	Condition
0x01	Command disallow	CSB state and Line-in state is not in the IDLE mode

Description:

This action is used for NSPK dynamic creation.

5.6.55.55 Action 0xEC: NSPK Switch Channel

Value	Parameter Description
0xEC	NSPK switches channel

Description:

This action is used to switch NSPK channel.

5.6.55.56 Action 0xED: nSPK Power Off All Speakers

Value	Parameter Description
0xED	nSPK powers off all the speakers

Description:

This action is used to execute the power off process. If nSPK is connected, this action is used to disconnect the remote nSPK and MCU receives EVENT [BTM_Utility_Rsp](#) (0x1B) with action_type 0x05.

After receiving the event, MCU can send MMI_Action [0x53](#), [0x54](#) to power off current SPK.

5.6.55.57 Action 0xEE: NSPK AFH SBC Encoding Audio Sync

Value	Parameter Description
0xEE	NSPK AFH SBC encoding audio synchronization

Description:

This action is used for NSPK AFH SBC encoding audio synchronization.

5.6.55.58 Action 0xF4: NSPK Enter NSPK Mode

Value	Parameter Description
0xF4	NSPK enters the NSPK mode

Description:

This action is used for NSPK to enter NSPK mode. It reports nSPK link status and CSB state.

5.6.55.59 Action 0xF5: NSPK Enter Broadcast Mode

Value	Parameter Description
0xF5	NSPK enters the broadcast mode

Description:

This action is used for NSPK to enter the Broadcast mode. It reports nSPK link status and CSB state.

5.6.55.60 Action 0xF6: NSPK Add Third SPK

Value	Parameter Description
0xF6	NSPK adds third SPK

Return Error: (Length: 1 Byte)

Value	Description	Condition
0x01	Command disallow	SPK acts as slave

Description:

This action is used to add third SPK.

5.6.55.61 Action 0xF7: NSPK Sound Re-synchronize

Value	Parameter Description
0xF7	NSPK_SOUND_SYNCHRONIZATION

Return Error: (Length: 1 Byte)

Value	Description	Condition
0x01	Command disallow	SPK acts as slave

Description:

This action is used to re-synchronize NSPK sound.

5.6.55.62 Action 0xF8: NSPK to Switch Connected Mode

Value	Parameter Description
0xF8	NSPK_CSB_CONNECTED_MODE_SWITCH

Return Error: (Length: 1 Byte)

Value	Description	Condition
0x01	Command disallow	SPK acts as slave

Description:

This action is used for NSPK to switch to connected mode.

5.6.55.63 Action 0xF9: NSPK to Switch Back to Last Mode

Value	Parameter Description
0xF9	NSPK_BACK_TO_LAST_MODE

Return Error: (Length: 1 Byte)

Value	Description	Condition
0x01	Command disallow	CSB state is not in IDLE mode

Description:

This action is used for NSPK to switch back to last mode.

5.7 UART Events

The following table lists the UART events used.

OP code	Event
0x00	Command_ACK
0x01	BTM_Status
0x02	Call_Status
0x03	Caller_ID
0x04	SMS_Received_Indication
0x05	Missed_Call_Indication
0x06	Phone_Max_Battery_Level
0x07	Phone_Current_Battery_Level
0x08	Roaming_Status
0x09	Phone_Max_Signal_Strength_Level
0x0A	Phone_Current_Signal_Strength_Level
0x0B	Phone_Service_Status
0x0C	BTM_Battery_Status
0x0D	BTM_Charging_Status
0x0E	Reset_To_Default
0x0F	Report_HF_Gain_Level
0x10	EQ_Mode_Indication
0x17	Read_Linked_Device_Information_Reply
0x18	Read_BTM_Version_Reply
0x19	Call_List_Report

.....continued	
OP code	Event
0x1A	AVC_Specific_Rsp
0x1B	BTM_Utility_Req
0x1C	Vendor_AT_Cmd_Reply
0x1D	Report_Vendor_AT_Event
0x1E	Read_Link_Status_Reply
0x1F	Read_Paired_Device_Record_Reply
0x20	Read_Local_BD_Address_Reply
0x21	Read_Local_Device_Name_Reply
0x22	Report_SPP/iAP_Data
0x23	Report_Link_Back_Status
0x24	REPORT_RING_TONE_STATUS
0x25	User_Confrim_SSP_Req
0x26	Report_AVRCP_Vol_Ctrl
0x27	Report_Input_Signal_Level
0x28	Report_iAP_Info
0x29	REPORT_AVRCP_ABS_VOL_CTRL
0x2A	Report_Voice_Prompt_Status
0x2D	Report_Type_Codec
0x2E	Report_Type_BTM_Setting
0x2F	Report_MCU_Update_Reply
0x30	Report_BTM_Initial_Status
0x31	LE_ANCS_Service_Event
0x32	LE_Signaling_Event
0x33	Report_nSPK_Link_Status
0x34	Report_nSPK_Vendor_Event
0x35	Report_nSPK_Audio_Setting
0x36	Report_Sound_Effect_Status
0x37	Report_Vendor_EEPROM_Data
0x38	REPORT_IC_VERSION_INFO
0x39	REPORT_LE_GATT_EVENT
0x3A	Report_BTM_Link_Mode

.....continued	
OP code	Event
0x3B	DSP_Dedicated_Event
0x3C	Report_nSPK_MISC_Event
0x3D	Report_nSPK_Exchange_Link_Info
0x3E	Report Customized_Information
0x3F	Report_CSB_CLK
0x40	Report_Read_Feature_List_Reply
0x41	REPORT_TEST_RESULT_REPLY
0x42	Report_Read_EEPROM_Data
0x43	PBAPC_Event
0x44	AVRCP_Browsing_Event

5.7.1 Command_Ack (0x00)

Event	Event Code	Event Parameters
Command_Ack	0x00	Command_ID, Status

Description:

This event is used to acknowledge the command. Status field of this event shows if the command is processed successfully or not.

Event Parameters:

Command_ID: (Length: 1 Byte)

Value	Parameter Description
0xXX	The Command ID of the command to acknowledge

Status: (Length: 1 Byte)

Value	Parameter Description
0x00	Command complete: BTM can handle this command.
0x01	Command disallow: BTM cannot handle this command.
0x02	Unknown command
0x03	Parameters error
0x04	BTM is busy: This status is used to notify host MCU that SPP data cannot be sent out in this moment because of ACL Tx buffer or RFCOMM credit issue. BTM sends Command_Ack event with the status "Command complete" once the SPP data can be processed.

.....continued	
Value	Parameter Description
0x05	BTM memory is full: This status is used to notify host MCU that SPP/BLE data cannot be sent out in this moment because of full OS heap memory. BTM sends Command_Ack event with the status "Command complete" once the SPP data can be processed and MCU must resend previous packet.
Others	Reserved

5.7.2 BTM_Status (0x01)

Event	Event Code	Event Parameters
BTM_Status	0x01	State, Link_Info, Parameter

Description:

This event is used to indicate the BTM status. When there is any change in the BTM status by using this event, status change is informed to the host MCU.

Event Parameters:

State: (Length: 1 Byte)

Value	Parameter Description
0x00	Power OFF state
0x01	Pairing state (discoverable mode)
0x02	Power ON state
0x03	Pairing successful
0x04	Pairing failed
0x05	HF/HS link established
0x06	A2DP link established
0x07	HF link disconnected
0x08	A2DP link disconnected
0x09	SCO link connected
0x0A	SCO link disconnected
0x0B	AVRCP link established
0x0C	AVRCP link disconnected
0x0D	Standard SPP connected
0x0E	Standard_SPP / iAP disconnected
0x0F	Standby state
0x10	iAP connected
0x11	ACL disconnected

.....continued	
Value	Parameter Description
0x12	MAP connected
0x13	MAP operation forbidden
0x14	MAP disconnected
0x15	ACL connected
0x16	SPP / iAP disconnected no_other Profile

Link_Info: For State 0x00, 0x01, 0x0F, 0x12, 0x13, 0x14 (Length: 1 Byte)

Value	Parameter Description
0xXX	Reserved

Link_Info: For State 0x02 (Length: 1 Byte)

Value	Parameter Description
0xXX	0: Power on 1: Already power on.

Link_Info: For State 0x03, 0x09, 0x0A (Length: 1 Byte)

Value	Parameter Description
0xXX	Current link ID

Link_Info: For State 0x04 (Length: 1 Byte)

Value	Parameter Description
0xXX	For pairing failure(0x04) case, this parameter indicates the reason: 0: Time out 1: Fail 2: Exit pairing mode

Link_Info: For State 0x05 0x06 0x0B (Length: 1 Byte)

Value	Parameter Description
0xXX	This parameter indicates both linked device and data base information. The format is shown below: Bit7-4 : linked device ID (0~7) Bit3-0 : linked data base (0 or 1)

Parameter: For State 0x05 (Length: 1 Byte)

Value	Parameter Description
0x00	HSP is connected

.....continued	
Value	Parameter Description
0x01	HFP is connected

Link_Info: For State 0x07 0x08 0x0C 0x15 (Length: 1 Byte)

Value	Parameter Description
0xXX	This parameter shows the linked data base (0 or 1)

Link_Info: For State 0x0D 0x10 (Length: 5-19 Bytes)

Value	Parameter Description
0xXX	Byte 0: This parameter indicates both link device and data base information. The format is shown below: Bit7-4 : linked device ID (0 to 7) Bit3-0 : linked data base(0, 1, 2)
0xXX	Byte 1: channel index Specify this byte for data transmission in 2 SPP or 2 iAP connection condition. MCU can copy this byte to channel_index byte of Send_SPP/iAP_Data if MCU transfers data to remote APP Bit0-1: Bluetooth connection index (data base index). Ranges from 0 to 3. Bit 2: LE connection indicator. Bit3-5: rfcmm index. Ranges from 0 - 7. Bit6-7: iAP session index. 1 is 1st session and 2 is 2nd session. 0 means not a iAP / iAP2 connection.
0xXX	Byte 2: UUID length. 2 or 16 bytes UUID
0XXXXXXXXXXXX	UUID

Link_Info: For State 0x0E (Length: 1 Byte)

Value	Parameter Description
0xXX	Byte 1: channel index Specify this byte for data transmission in 2 SPP or 2 iAP connection condition. MCU can copy this byte to channel_index byte of Send_SPP/iAP_Data if MCU transfers data to remote APP Bit0-1: Bluetooth connection index (data base index). Ranges from 0-3. Bit 2: LE connection indicator Bit3-5: rfcmm index. Ranges from 0 - 7. Bit6-7: iAP session index. 1 is 1st session and 2 is 2nd session. 0 means not a iAP / iAP2 connection.

Link_Info: For State 0x11 (Length: 1 Byte)

Value	Parameter Description
0x00	Disconnection
0x01	Link loss

Link_Info: For State 0x16 (Length: 6 Byte)

BT_Addr: (Length:6 Bytes)

Value	Parameter Description
0XXXXXXXXXXXXX	The Bluetooth address of the target device that BTM rejects the SPP connection

5.7.3 Call_Status (0x02)

Event	Event Code	Event Parameters
Call_Status	0x02	Data_Base_Index, Call_Status

Description:

This event is used to indicate about the HF call status of BTM.

Event Parameters:

Data_Base_Index: (Length: 1 Byte)

Value	Parameter Description
0x00	Database 0 for a dedicated link
0x01	Database 1 for a dedicated link

Call_Status: (Length: 1 Byte)

Value	Parameter Description
0x00	Idle
0x01	Voice dial
0x02	Incoming call
0x03	Outgoing call
0x04	Call active
0x05	Call active with a call waiting
0x06	Call active with a call hold

5.7.4 Caller_ID (0x03)

Event	Event Code	Event Parameters
Caller_ID	0x03	Data_Base_Index, Number

Description:

This event is used to indicate the caller ID of the incoming call.

Event Parameters:

Data_Base_Index: (Length: 1 Byte)

Value	Parameter Description
0x00	Database 0 for a dedicated link
0x01	Database 1 for a dedicated link

Number: (Length: N Bytes)

Value	Parameter Description
0xXX..	Caller Id or phone number

5.7.5 SMS_Received_Indication (0x04)

Event	Event Code	Event Parameters
SMS_Received_Indication	0x04	Data_Base_Index, Indication

Description:

This event is used to indicate about the SMS status that BTM received from mobile phone.

Event Parameters:

Data_Base_Index: (Length: 1 Byte)

Value	Parameter Description
0x00	Database 0 for dedicate link
0x01	Database 1 for dedicate link

Indication: (Length: 1 Byte)

Value	Parameter Description
0x00	No new SMS received
0x01	New SMS received

5.7.6 Missed_Call_Indication (0x05)

Event	Event Code	Event Parameters
Missed_Call_Indication	0x05	Data_Base_Index, Information

Description:

This event is used to indicate the BTM received missed call notification from mobile phone.

Event Parameters:

Data_Base_Index: (Length: 1 Byte)

Value	Parameter Description
0x00	Database 0 for a dedicated link

.....continued	
Value	Parameter Description
0x01	Database 1 for a dedicated link

Information: (Length: 1 Byte)

Value	Parameter Description
0xXX	Reserved

5.7.7 Phone_Max_Battery_Level (0x06)

Event	Event Code	Event Parameters
Phone_Max_Battery_Level	0x06	Data_Base_Index, Max_Battery_Level

Description:

This event is used to indicate maximum battery level of the mobile phone that BTM received from mobile phone.

Event Parameters:

Data_Base_Index: (Length: 1 Byte)

Value	Parameter Description
0x00	Database 0 for a dedicated link
0x01	Database 1 for a dedicated link

Max_Battery_Level: (Length: 1 Byte)

Value	Parameter Description
0xXX	Maximum battery level

5.7.8 Phone_Current_Battery_Level (0x07)

Event	Event Code	Event Parameters
Phone_Current_Battery_Level	0x07	Data_Base_Index, Battery_Level

Description:

This event is used to indicate the battery level of the mobile phone that BTM received from the mobile phone.

Event Parameters:

Data_Base_Index: (Length: 1 Byte)

Value	Parameter Description
0x00	Database 0 for a dedicated link
0x01	Database 1 for a dedicated link

Battery_Level: (Length: 1 Byte)

Value	Parameter Description
0xXX	Current battery level

5.7.9 Roaming_Status (0x08)

Event	Event Code	Event Parameters
Roaming_Status	0x08	Data_Base_Index, Status

Description:

This event is used to indicate the roaming status that BTM received from mobile phone.

Event Parameters:

Data_Base_Index: (Length: 1 Byte)

Value	Parameter Description
0x00	Database 0 for a dedicated link
0x01	Database 1 for a dedicated link

Status: (Length: 1 Byte)

Value	Parameter Description
0x00	Non roaming
0x01	Roaming

5.7.10 Phone_Max_Signal_Strength_Level (0x09)

Event	Event Code	Event Parameters
Phone_Max_Signal_Strength_Level	0x09	Data_Base_Index, Signal_Level

Description:

This event is used to indicate the maximum signal strength level that BTM received from mobile phone.

Event Parameters:

Data_Base_Index: (Length: 1 Byte)

Value	Parameter Description
0x00	Database 0 for a dedicated link
0x01	Database 1 for a dedicated link

Signal_Level: (Length: 1 Byte)

Value	Parameter Description
0x00	Maximum signal strength of mobile phone

5.7.11 Phone_Current_Signal_Strength_Level (0x0A)

Event	Event Code	Event Parameters
Phone_Current_Signal_Strength_Level	0x0A	Data_Base_Index, Signal_Level

Description:

This event is used to indicate the current signal strength level that BTM received from mobile phone.

Event Parameters:

Data_Base_Index: (Length: 1 Byte)

Value	Parameter Description
0x00	Database 0 for a dedicated link
0x01	Database 1 for a dedicated link

Signal_Level: (Length: 1 Byte)

Value	Parameter Description
0x00	Current signal strength of mobile phone

5.7.12 Phone_Service_Status (0x0B)

Event	Event Code	Event Parameters
Phone_Service_Status	0x0B	Data_Base_Index, Service

Description:

This event is used to indicate the service status of BTM received from mobile phone.

Event Parameters:

Data_Base_Index: (Length: 1 Byte)

Value	Parameter Description
0x00	Database 0 for a dedicated link
0x01	Database 1 for a dedicated link

Service: (Length: 1 Byte)

Value	Parameter Description
0x00	No service available
0x01	Service available

5.7.13 BTM_Battery_Status (0x0C)

Event	Event Code	Event Parameters
BTM_Battery_Status	0x0C	Battery_Status, Voltage_Level

Description:

This event is used to indicate the battery status of BTM.

Event Parameters:

Battery_Status: (Length: 1 Byte)

Value	Parameter Description
0x00	Dangerous level, and will auto shutdown
0x01	Low level
0x02	Normal level
0x03	High level
0x04	Full level
0x05	In charging
0x06	Charging is completed

Voltage_Level: (Length: 1 Byte)

Value	Parameter Description
0x00	batt < 3.1V
0x01	3.1V <= batt < 3.2V
0x02	3.2V <= batt < 3.3V
0x03	3.3V <= batt < 3.4V
0x04	3.4V <= batt < 3.5V
0x05	3.5V <= batt < 3.6V
0x06	3.6V <= batt < 3.7V
0x07	3.7V <= batt < 3.8V
0x08	3.8V <= batt < 3.9V
0x09	3.9V <= batt < 4.0V
0x0A	4.0V <= batt < 4.1V
0x0B	4.1V <= batt < 4.2V
0x0C	4.2V <= batt

5.7.14 BTM_Charging_Status (0x0D)

Event	Event Code	Event Parameters
BTM_Charging_Status	0x0D	Charger_Status, Charger_Type

Description:

This event is used to indicate the charger status and charger type.

Event Parameters:

Charger_Status: (Length: 1 Byte)

Value	Parameter Description
0x00	Charger is not plugged in
0x01	In charging
0x02	Charging is completed
0x03	Charging is failed
0x04	Charger type report

Charger_Type: (Length: 1 Byte)

Value	Parameter Description
0x00	BC_TYPE_UNKNOWN
0x01	BC_TYPE_NON_DCD
0x02	BC_TYPE_SDP
0x03	BC_TYPE_DCP
0x04	BC_TYPE_CDP
0x10	BC_TYPE_SONY
0x20	BC_TYPE_APPLE_2_5W
0x21	BC_TYPE_APPLE_5W
0x22	BC_TYPE_APPLE_10W
0x23	BC_TYPE_APPLE_12W
Others	Reserved

5.7.15 Reset_To_Default (0x0E)

Event	Event Code	Event Parameters
Reset_To_Default	0x0E	Reserved

Description:

This event is used to indicate that BTM has completed the Master Reset for the MMI command (0x56) trigger.

Event Parameters:

Reserved: (Length: 2 Bytes)

Value	Parameter Description
0xFFFF	Database 0 for a dedicated link

5.7.16 Report_HF_Gain_Level (0x0F)

Event	Event Code	Event Parameters
Report_HF_Gain_Level	0x0F	Data_Base_Index, Gain_Level

Description:

This event is used to report the HF gain level set by remote Audio Gateway (phone).

Event Parameters:

Data_Base_Index: (Length: 1 Byte)

Value	Parameter Description
0x00	Database 0 for a dedicated HF/HS device
0x01	Database 1 for a dedicated HF/HS device

Gain_Level: (Length: 1 Byte)

Value	Parameter Description
0x00-0x0F	Gain level that synched with HF device

5.7.17 EQ_Mode_Indication (0x10)

Event	Event Code	Event Parameters
EQ_Mode_Indication	0x10	EQ_Mode,Reserved

Description:

This event is used to notify the host MCU that EQ mode setting is changed by MMI or EQ_Mode_Setting command.

Event Parameters:

EQ_Mode (Length: 1 Byte)

Value	Parameter Description
0x00	Off mode
0x01	Soft mode
0x02	Bass mode
0x03	Treble mode
0x04	Classical mode
0x05	Rock mode
0x06	Jazz mode
0x07	Pop mode
0x08	Dance mode
0x09	R&B mode
0x0B	User mode 1

Reserved: (Length: 1 Byte)

Value	Parameter Description
0xXX	Reserved

5.7.18 Read_Linked_Device_Information_Reply (0x17)

Event	Event Code	Event Parameters
Read_Linked_Device_Information_Reply	0x17	Data_Base_Index, Type, Info

Description:

This event is used to reply Read_Linked_Device_Information command.

Event Parameters:

Data_Base_Index: (Length: 1 Byte)

Value	Parameter Description
0x00	Database 0 for a dedicated link
0x01	Database 1 for a dedicated link

Type: (Length: 1 Byte)

Value	Parameter Description
0x00	Replies the device name
0x01	Replies the in-band ringtone status
0x02	Replies the remote device is a iAP device or standard SPP device
0x03	Replies the remote device supported AVRCP function
0x04	Replies the HF&A2DP gain
0x05	Replies the Line In gain
0x06	Replies the A2DP used codec type
others	Reserved

Info: for Type 0x00 (Length: N Byte)s

Value	Parameter Description
0xXX...	N bytes Bluetooth name with NULL terminated (N <= 249 with NULL terminated). Note: If remote device responds empty name string, BTM reports name with data NULL terminated (0x00) only.

Info: for Type 0x01 (Length: 1 Byte)

Value	Parameter Description
0x00	Disabled
0x01	Enabled

Info: for Type 0x02 (Length: 1 Byte)

Value	Parameter Description
0x00	Standard SPP device
0x01	iAP device

Info: for Type 0x03 (Length: 1 Byte)

Value	Parameter Description
0xXX	Bit Mask Bit0: media player status notification Bit1: absolute volume control

Info: for Type 0x04 (Length: 1 Byte)

Value	Parameter Description
0xXX	bit[3:0]: A2DP gain bit[7:4]: HF gain

Info: for Type 0x05 (Length: 1 Byte)

Value	Parameter Description
0xXX	Line in gain

Info: for Type 0x06 (Length: 1 Byte)

Value	Parameter Description
0x00	SBC
0x02	AAC
0xFF	Vendor (LDAC)
Others	Reserved

5.7.19 Read_BTM_Version_Reply (0x18)

Event	Event Code	Event Parameters
Read_BTM_Version_Reply	0x18	Type, Version

Description:

This event is used to reply Read_BTM_Version command.

Event Parameters:

Type: (Length: 1 Byte)

Value	Parameter Description
0x00	UART version
0x01	BTM FW version

.....continued	
Value	Parameter Description
0x02 ⁽¹⁾	EEPROM version
0xFF	Reserved

Note:

1. Check the exception notice in summary table.

Version: for Type 0x00 (Length: 2 Bytes)

Value	Parameter Description
0xFFFF	1st byte: UART Command Main version 2nd byte: UART Command Sub version for example, 00 07 means version 0.07

Version: for Type 0x01 (Length: 2 Bytes)

Value	Parameter Description
0xFFFF	1st byte: Firmware Main version 2nd byte: Firmware Sub version for example. 00 07 means version 0.07

Version: for Type 0x02 (Length: 2 Bytes)

Value	Parameter Description
0xFFFF	1st byte: EEPROM Main version 2nd byte: EEPROM Sub version for example, 00 07 means version 0.07

Version: for Type 0xFF (Length: 2 Bytes)

Value	Parameter Description
0xFFFF	Reserved

5.7.20 Call_List_Report (0x19)

Event	Event Code	Event Parameters
Call_List_Report	0x19	Call_List_String (ASCII)

Description:

This event is used to notify +CLCC information for the MMI command (0x0F).

Event Parameters:

Call_List_String: (Length: N Bytes)

Value	Parameter Description
0XXXXXXXX...	"+CLCC: xxxxx"

Event	Event Code	Event Parameters
Access_Finish	0x16	Type, Status

Type: (Length: 1 Byte)

Value	Parameter Description
0x00	Report call list is finished

Status: (Length: 1 Byte)

Value	Parameter Description
0x00	Successful
Others	Error: when AG do not support this command, it will responds with +ERROR, and SPK module reports this to MCU

5.7.21 AVC_Vendor_Dependent_Response (0x1A)

Event	Event Code	Event Parameters
AVC_Vendor_Dependent_Response	0x1A	Data_Base_Index, AVC_Rsp_Payload

Description:

This event is used to reply AVC_Vendor_Dependent_Cmd command. For detailed response information, refer to AVRCP Specification.

Event Parameters:

Data_Base_Index: (Length: 1 Byte)

Value	Parameter Description
0x00	Database 0 for a dedicated link
0x01	Database 1 for a dedicated link

AVC_Rsp_Payload: (Length: N Byte)

Value	Parameter Description
Byte0	Response type: 0x08: Not implemented 0x09: Accept 0x0A: Reject 0x0C: Stable 0x0D: Changed 0x0F: Interim
Byte1	Subunit_type:5 bit Subunit_ID:3 bit: 0x48
Byte2	Opcode: 0x00 (Vendor dependent)

.....continued	
Value	Parameter Description
Byte3-5	Company ID: 0x00 0x19 0x58
Byte6	AVRCP1.3 AVC specific command PDU Id
Byte7	Packet Type: 0x00 (single packet)
Byte8-9	Response parameter length
Byte10-N	Response parameter

5.7.22 BTM_Utility_Req (0x1B)

Event	Event Code	Event Parameters
BTM_Utility_Req	0x1B	Action_Type, Parameter

Description:

This event is used to request host MCU to perform specific function.

Event Parameters:

Action_Type: (Length: 1 Byte)

Value	Parameter Description
0x00	BTM asks MCU to control the external amplifier
0x01	BTM reports the Aux line-in status to Host MCU.
0x02	BTM notifies MCU to handle BTM or MCU update process
0x03	BTM notifies MCU eeprom update finish
0x04	BTM reports the A2DP codec status to Host MCU.
0x05	[NSPK] BTM notifies MCU to sync power off BTM
0x06	[NSPK] BTM notifies MCU to sync Volume Control
0x07	[NSPK] BTM notifies MCU to sync internal gain
0x08	[NSPK] BTM notifies MCU to sync A2DP absolute volume
0x09	[NSPK] BTM notifies MCU current channel setting
0x0A	[NSPK] BTM notifies MCU synced NSPK power condition
0x0B	[NSPK] BTM notifies MCU NSPK command success
0x0C	[NSPK] BTM notifies MCU NSPK command failure
0x0D	[NSPK] BTM notifies MCU certain NSPK Slave status is changed
0x0E	Reserved
0x0F	Reserved
0x10	Reserved

.....continued

Value	Parameter Description
0x11	[NSPK] BTM notify MCU to sync Line-in absolute volume
0x12	[NSPK] BTM notify MCU that NSPK connection complete.
0x13	BTM reports AVDTP start state to Host MCU.
0x14	BTM reports AVDTP suspend state to Host MCU.
others	Reserved

Parameter: For Action_Type 0x00 (Length: 1 Byte)

Value	Parameter Description
0x00	Mute or switch off amplifier
0x01	Unmute or switch on amplifier
Others	Reserved

Parameter: For Action_Type 0x01 (Length: 1 Byte)

Value	Parameter Description
0x00	Aux line in is unplugged.
0x01	Aux line in is plugged.
0x02	Aux line in is plugged and with audio signal.
0x03	Aux line in is plugged and silence.
Others	Reserved

Parameter: For Action_Type 0x02 (Length: 1 Byte)

Value	Parameter Description
0x00	BTM FW update
0x01	MCU FW update
Others	Reserved

Parameter: For Action_Type 0x03 (Length: 1 Byte)

Value	Parameter Description
0x00	EEPROM update is successful
Others	Reserved

Parameter: For Action_Type 0x04 (Length: 1 Byte)

Value	Parameter Description
0x00	A2DP stop

.....continued

Value	Parameter Description
0x01	A2DP start
Others	Reserved

Parameter: For Action_Type 0x06 (Length: 1 Byte)

Value	Parameter Description
0x00	Volume up
0x01	Volume down
Others	Reserved

Parameter: For Action_Type 0x07 (Length: 1 Byte)

Value	Parameter Description
0x0X	Fist 4 bits indicate A2DP gain level
0xX0	Last 4 bits indicate Line In gain level

Parameter: For Action_Type 0x08 (Length: 1 Byte)

Value	Parameter Description
0xXX	A2DP absolute volume

Parameter: For Action_Type 0x09 (Length: 1 Byte)

Value	Parameter Description
0x00	No mix channel
0x01	L+L channel
0x02	R+R channel
0x03	(L+R) / 2 -> L, (L+R) / 2 -> R channel

Parameter: For Action_Type 0x0A (Length: 1 Byte)

Value	Parameter Description
0x00	Battery power with low battery
0x01	Adaptor power with low battery
0x02	Battery power
0x03	Adapter power

Parameter: For Action_Type 0x0B 0x0C (Length: 1 Byte)

Value	Parameter Description
0xXX	Audio effect type

Parameter: For Action_Type 0x0D (Length: 1 Byte)

Value	Parameter Description
0xXX	Reserved

Parameter: For Action_Type 0x11 (Length: 1 Byte)

Value	Parameter Description
0xXX	Line-in absolute volume

Parameter: For Action_Type 0x12 (Length: 1 Byte)

Value	Parameter Description
0x01	NSPK connection is complete

Parameter: For Action_Type 0x13, 0x14 (Length: 1 Byte)

Value	Parameter Description
0xXX	Data_Base_Index

5.7.23 Vendor_AT_Cmd_Rsp (0x1C)

Event	Event Code	Event Parameters
Vendor_AT_Cmd_Rsp	0x1C	Data_Base_Index, Status

Description:

This event is used to reply Vendor_AT_Cmd (0x0A) command.

Event Parameters:

Data_Base_Index: Length: 1 Byte

Value	Parameter Description
0x00	database 0 for dedicate link
0x01	database 1 for dedicate link

Status: (Length: 1 Byte)

Value	Parameter Description
0x00	AG response OK
0x01	AG response ERROR
0x02	No response from AG
Others	Reserved

5.7.24 Report_Vendor_AT_Event (0x1D)

Event	Event Code	Event Parameters
Report_Vendor_AT_Event	0x1D	Data_Base_Index, Result_Payload

Description:

This event is used to reply Vendor_AT_Cmd (0x0A) command.

Event Parameters:

Data_Base_Index: (Length: 1 Byte)

Value	Parameter Description
0x00	Database 0 for a dedicated link
0x01	Database 1 for a dedicated link

Result_Payload: (Length: N Byte)

Value	Parameter Description
0xXX...	Result code. For example, AG sends result code as "+test:1" , the result code will be "+test:1"

5.7.25 Read_Link_Status_Reply (0x1E)

Event	Event Code	Event Parameters
Read_Link_Status_Reply	0x1E	Device_State, Database0_Connect_Status, Database1_Connect_Status, Database0_Play_Status, Database1_Play_Status, Database0_Stream_Status, Database1_Stream_Status,

Description:

This event is used to reply the Read_Link_Status(0X0D) command.

Event Parameters:

Device_State: (Length: 1 Byte)

Value	Parameter Description
0x00	Power OFF state
0x01	Pairing state (discoverable mode)
0x02	Standby state
0x03	Connected state with only HF profile connected
0x04	Connected state with only A2DP profile connected
0x05	Connected state with only SPP profile connected
0x06	Connected state with multi-profile connected

Database0_Connect_Status / Database1_Connect_Status: (Length: 1 Byte)

Value	Parameter Description
0xXX	1 indicates connected Bit0 : A2DP profile signaling channel is connected Bit1 : A2DP profile stream channel is connected Bit2 : AVRCP profile is connected Bit3 : HF profile is connected Bit4 : SPP is connected

Database0_Play_Status / Database1_Play_Status: (Length: 1 Byte)

Value	Parameter Description
0x00	STOP
0x01	PLAYING
0x02	PAUSED
0x03	FWD_SEEK
0x04	REV_SEEK
0x05	FAST_FWD
0x06	REWIND
0x07	WAIT_TO_PLAY
0x08	WAIT_TO_PAUSE

Database0_Stream_Status / Database1_Stream_Status: (Length: 1 Byte)

Value	Parameter Description
0x00	No streaming
0x01	Streaming is going on

5.7.26 Read_Paired_Device_Record_Reply (0x1F)

Event	Event Code	Event Parameters
Read_Paired_Device_Record_Reply	0x1F	Paired_Device_Number, Paired_Record

Description:

This event is used to reply the Read_Paired_Device_Record (0X0E) command.

Event Parameters:

Paired_Device_Number: (Length: 1 Byte)

Value	Parameter Description
0xXX	Paired device number

Paired_Record: (7 Bytes Per Record) Length: (7*Total Record) Bytes

Value	Parameter Description
0XXXXXXXXXXXXXXXXX	Byte 0: Link priority : 1 is the highest (newest device) and 4 is the lowest (oldest device) Byte 1-6: Linked device BD address (6 bytes with low byte first)

5.7.27 Read_Local_BD_Address_Reply (0x20)

Event	Event Code	Event Parameters
Read_Local_BD_Address_Reply	0x20	BD_Address

Description:

This event is used to reply to the Read_Local_BD_Address (0X0F) command.

Event Parameters:

BD_Address: (Length: 6 Bytes)

Value	Parameter Description
0XX..	BD address with lower byte first

5.7.28 Read_Local_Device_Name_Reply (0x21)

Event	Event Code	Event Parameters
Read_Local_Device_Name_Reply	0x21	Name_Length, Device_Name

Description:

This event is used to reply to the Read_Local_Device_Name (0X10) command.

Event Parameters:

Name_Length: (Length: 1 Byte)

Value	Parameter Description
0XX..	Name length

Device_Name: Length: Name_Length Bytes

Value	Parameter Description
0XX..	Device name with length name length

5.7.29 Reprt_SPP/iAP/LE_Data (0x22)

Event	Event Code	Event Parameters
Report_SPP/iAP/LE_Data	0x22	Channel_Index, Type, Total_Length, Payload_Length, Payload

Description:

This event is used to send SPP/iAP /LE data coming from remote device to host MCU.

Event Parameters:

Channel_Index: (Length: 1 Byte)

Value	Parameter Description
0x01	Specify this byte for data transmission in 2 SPP / 2 iAP / LE connection. Bit0-1: Bluetooth connection index (data base index). Ranges from 0~3. Bit2: LE connection indicator Bit3-5: rfcomm index. Ranges from 0 to 7. Bit6-7: iAP session index. 1 is 1st session and 2 is 2nd session. 0 means not a iAP/ iAP2 connection

Type: (Length: 1 Byte)

Value	Parameter Description
0x00	Single packet
0x01	Fragmented start packet
0x02	Fragmented continue packet
0x03	Fragmented end packet

Total_Length: (Length: 2 Bytes)

Value	Parameter Description
0xFFFF	Total payload length

Payload_Length: (Length: 2 Bytes)

Value	Parameter Description
0xFFFF	Payload length in this packet

Payload: (Length: N Bytes)

Value	Parameter Description
0xFFFF...	Payload

5.7.30 Reprt_Link_Back_Status (0x23)

Event	Event Code	Event Parameters
Report_Link_Back_Status	0x23	Link_Back_Status, Link_Back_Result

Description:

This event is used to indicate the link back status of BTM.

Event Parameters:

Link_Back_Status: (Length: 1 Byte)

Value	Parameter Description
0x00	ACL connection
0x01	HF connection
0x02	A2DP connection
0x03	SPP connection
0x04	Under page state

Link_Back_Result: for Link_Back_Status 0x00 (Length: 1 Byte)

Value	Parameter Description
0xXX	0xFF: fail Others: success Bit7-4: linked device ID (0-7) Bit3-0: linked data base (0 or 1)

Link_Back_Result: for Link_Back_Status 0x01~0x03 (Length: 1 Byte)

Value	Parameter Description
0x00	Success
0x01	Failed

5.7.31 Ringtone_Status_Indication (0x24)

Event	Event Code	Event Parameters
Ringtone_Status_Indication	0x24	Ringtone_Mode, Status

Description:

This event is used to indicate the ringtone mode and ringtone playback status.

Event Parameters:

Ringtone_Mode: (Length: 1 Byte)

Value	Parameter Description
0xXX	Refer Tone Type

Status: (Length: 1 Byte)

Value	Parameter Description
0x00	Ringtone playback is about to be stopped
0x01	Ringtone playback is about to start

5.7.32 User_Confirm_SSP_Req (0x25)

Event	Event Code	Event Parameters
User_Confirm_SSP_Req	0x25	Data_Base_Index, Numeric_Value

Description:

This event is used to indicate that user confirmation of a numeric value is required. The host shall reply with the User_Confirm_SSP_Req_Reply command to indicate whether user has confirmed the numeric value or not. If the host has output capability it shall display the Numeric_Value to the user. It shall reply the yes/no response from the user.

Event Parameters:

Data_Base_Index: (Length: 1 Byte)

Value	Parameter Description
0x00	Database 0 for a dedicated link
0x01	Database 1 for a dedicated link

Numeric_Value: (Length: 4 Bytes)

Value	Parameter Description
0x00000000~0x000F423F	Numeric value to be displayed. Valid values are from decimal 000000 to 999999.

5.7.33 Report_AVRCP_Volume_Ctrl (0x26)

Event	Event Code	Event Parameters
Report_AVRCP_Volume_Ctrl	0x26	Data_Base_Index, Volume_Ctrl_Indication

Description:

This event is used to indicate the received AVRCP volume control to MCU. For AVRCPv1.0, remote device may request speaker to adjust volume up or down.

Event Parameters:

Data_Base_Index: (Length: 1 Byte)

Value	Parameter Description
0x00	Database 0 that related to a dedicated A2DP link
0x01	Database 1 that related to a dedicated A2DP link

Volume_Ctrl_Indication: (Length: 1 Byte)

Value	Parameter Description
0x00	Volume up
0x01	Volume down

5.7.34 Report_Input_Signal_Level (0x27)

Event	Event Code	Event Parameters
Report_Input_Signal_Level	0x27	Report_Mask_P0, Report_Mask_P1, Report_Mask_P2, Report_Mask_P3, Input_level_P0, Input_level_P1, Input_level_P2, Input_level_P3,

Description:

This event shall be sent under two condition:

- When the MCU sets the specific GPIOs as input by GPIO_CTRL(0x1E) command
- When input GPIO input signal level is changed

Event Parameters:

Report_Mask_P0: (Length: 1 Byte)

Value	Parameter Description
0bXXXXXXXX	Bit mask of P0 for input signal level reporting. Bit 0: P0_0 input signal level reporting indication Bit 1: P0_1 input signal level reporting indication

Report_Mask_P1: (Length: 1 Byte)

Value	Parameter Description
0bXXXXXXXX	Bit mask of P1 for input signal level reporting. Bit 0: P1_0 input signal level reporting indication Bit 1: P1_1 input signal level reporting indication

Report_Mask_P2: (Length: 1 Byte)

Value	Parameter Description
0bXXXXXXXX	Bit mask of P2 for input signal level reporting. Bit 0: P2_0 input signal level reporting indication Bit 1: P2_1 input signal level reporting indication

Report_Mask_P3: (Length: 1 Byte)

Value	Parameter Description
0bXXXXXXXX	Bit mask of P3 for input signal level reporting. Bit 0: P3_0 input signal level reporting indication Bit 1: P3_1 input signal level reporting indication

Input_level_P0: (Length: 1 Byte)

Value	Parameter Description
0bXXXXXXXX	Input signal level reporting of P0. Bit 0: P0_0 input signal level. Bit 1: P0_1 input signal level.

Input_level_P1: (Length: 1 Byte)

Value	Parameter Description
0bXXXXXXXX	Input signal level reporting of P1. Bit 0: P1_0 input signal level. Bit 1: P1_1 input signal level.

Input_level_P2: (Length: 1 Byte)

Value	Parameter Description
0bXXXXXXXX	Input signal level reporting of P2. Bit 0: P2_0 input signal level. Bit 1: P2_1 input signal level.

Input_level_P3: (Length: 1 Byte)

Value	Parameter Description
0bXXXXXXXX	Input signal level reporting of P3. Bit 0: P3_0 input signal level. Bit 1: P3_1 input signal level.

5.7.35 Report_iAP_Info (0x28)

Event	Event Code	Event Parameters
Report_iAP_Info	0x28	Type, Parameter

Description:

This event is used to report the iAP data session status.

Event Parameters:

Type: (Length: 1 Byte)

Value	Parameter Description
0x00	Data session status
0x01	Authentication completed

Parameter: For Type 0x00 (Length: 1 Byte)

Value	Parameter Description
0xXX	Bit0-3: data session status <ul style="list-style-type: none"> • 0x00: data session close • 0x01: data session open Bit4-7: (only valid for open session) protocol index

Parameter: For Type 0x01 (Length: 1 Byte)

Value	Parameter Description
0x00	iAP authentication OK
0x01	iAP2 authentication OK

5.7.36 Report_AVRCP_ABS_Volume_Level (0x29)

Event	Event Code	Event Parameters
Report_AVRCP_ABS_Volume_Level	0x29	Data_Base_Index, Absolute_Volume

Description:

This event is used to indicate the received AVRCP absolute volume level to MCU. For AVRCPv1.0, remote device may request speaker to change the volume level.

Event Parameters:

Data_Base_Index: (Length: 1 Byte)

Value	Parameter Description
0x00	Database 0 related to a dedicated A2DP link
0x01	Database 1 related to a dedicated A2DP link

Absolute_Volume: (Length: 1 Byte)

Value	Parameter Description
0xXX	Reports in range 0x00 to 0x7F to indicate the percentage of total (maximum) volume level

5.7.37 Report_Voice_Prompt_Status (0x2A)

Event	Event Code	Event Parameters
Report_Voice_Prompt_Status	0x2A	Status, Reserved

Description:

This event is used to report the TTS status.

Event Parameters:

Status: (Length: 1 Byte)

Value	Parameter Description
0x01	Ready
Others	Reserved

Reserved: (Length: 1 Byte)

Value	Parameter Description
0xXX	Reserved

5.7.38 Report_Type_Codec (0x2D)

Event	Event Code	Event Parameters
Report_Type_Codec	0x2D	Sampling_Frequency, Mode

Description:

This event is used to inform MCU about the next I2S state which DSP prepares to enter. Therefore, MCU can configure its external CODEC to its corresponding state.

Event Parameters:

Sampling_Frequency: (Length: 1 Byte)

Value	Parameter Description
0x00	8 KHz sample rate
0x02	16 KHz sample rate
0x04	32 KHz sample rate
0x05	48 KHz sample rate
0x06	44.1 KHz sample rate
0x07	88 KHz sample rate
0x08	96 KHz sample rate
Others	Reserved

Mode: (Length: 1 Byte)

Value	Parameter Description
0x00	No action
0x01	Prepare
0x02	Audio in mode
0x03	PCM mode
0x04	A2DP decode mode
0x06	SCO(HF) mode
0x07	Tone

.....continued	
Value	Parameter Description
0x08	Voice prompt
Others	Reserved

5.7.39 Report_Type_BTMM_Settings (0x2E)

Event	Event Code	Event Parameters
Report_Type_BTMM_Settings	0x2E	Setting_Type, Setting_Value

Description:

This event is used to report the BTM setting status to MCU.

Event Parameters:

Setting_Type: (Length: 1 Byte)

Value	Parameter Description
0x00	Pairing timeout setting
0x01	Supported codec type setting
0x02	BTM standby mode setting
Others	Reserved

Setting_Value: For Setting_Type 0x00 (Length: 1 Byte)

Value	Parameter Description
0xXX	Reply pairing timeout setting with unit 30 second

Setting_Value: For Setting_Type 0x01 (Length: 1 Byte)

Value	Parameter Description
0xXX	Reply is supported with codec type with bit mask: Bit0: SBC (Mandatory, must always be set) Bit1: AAC Bit2: VENDOR

Setting_Value: For Setting_Type 0x02 (Length: 1 Byte)

Value	Parameter Description
0x00	BTM Standby mode is disabled
0x01	BTM Standby mode is enabled
Others	Reserved

5.7.40 Report_MCU_Update_Reply (0x2F)

Event	Event Code	Event Parameters
Report_MCU_Update_Reply	0x2F	Action, Data

Description:

This event is to reply MCU_Update_Cmd(0x26) command.

Event Parameters:

Action: (Length: 1 Byte)

Value	Parameter Description
0x00	Replies total update Bin size, data(4bytes)
0x01	Replies start or continue Bin data
0x02	Replies last Bin data
others	Reserved

5.7.41 Report_BTM_Initial_Status (0x30)

Event	Event Code	Event Parameters
Report_BTM_Initial_Status	0x30	Status, Reserved

Description:

This event is to report the initialization status to MCU.

Event Parameters:

Action: (Length: 1 Byte)

Value	Parameter Description
0x00	Initialization completed
Others	Reserved

Reserved: (Length: 1 Byte)

Value	Parameter Description
0xXX	Reserved

5.7.42 LE_ANCS_Service_Event (0x31)

Event	Event Code	Event Parameters
LE_ANCS_Service_Event	0x31	SubEvent_Type, SubEvent_Payload

Description:

This event is used to report many kinds of notifications that are generated on iOS devices by Bluetooth Bluetooth Low Energy link.

Event Parameters:

SubEvent_Type: (Length: 1 Byte)

Value	Parameter Description
0x00	ANCS Search event
0x01	ANCS GetNotification attribute event
0x02	ANCS notification source event
0x03	ANCS data source event
0x04-0xFF	Reserved

SubEvent_Payload: For SubEvent_Type 0x00

Payload Description: Reports the ANCS search status to Notification Client.

Search Status: (Length: 1 Byte)

Value	Parameter Description
0x00	ANCS found
0x01	ANCS not found

SubEvent_Payload: For SubEvent_Type 0x01

Payload Description: Report the ANCS GetNotification status to Notification Client.

GetNotification Event Status: (Length: 1 Byte)

Value	Parameter Description
0x00	No error
0x01	Invalid handle
0x02	Read not permitted
0x03	Write not permitted
0x04	Invalid PDU
0x05	Insufficient authentication
0x06	Request not supported
0x07	Invalid offset
0x08	Insufficient authorization
0x09	Prepare queue full
0x0A	Attribute not found
0x0B	Attribute not long
0x0C	Insufficient encryption key size
0x0D	Invalid attribute value length
0x0E	Unlikely error

.....continued	
Value	Parameter Description
0x0F	Unlikely error
0x10	Unsupported group type
0x11	Insufficient encryption
0x12-0x7F	Reserved
0x80-0x9F	Reserved for Application error
0xA0	ANCS Error Code: Unknown Command (ANCS Spec)
0xA1	ANCS Error Code: Invalid Command (ANCS Spec)
0xA2	ANCS Error Code: Invalid Parameters (ANCS Spec)
0xA3	ANCS Error Code: Action Failed (ANCS Spec)
0xA4-0xFF	Reserved for Application error

SubEvent_Payload: For SubEvent_Type 0x02

Payload Description: Reports the data of ANCS notification source to Notification Client.

Notification Source Value: (Length: N Bytes)

Value	Parameter Description
.....	Refer to the Apple Notification Center Service v1.1 document, the format of a Notification source.

SubEvent_Payload: For SubEvent_Type 0x03

Payload Description: Reports the data of ANCS data source to Notification Client.

Data Source Value: (Length: N Bytes)

Value	Parameter Description
.....	Refer to the Apple Notification Center Service v1.1 document, the format of a Data source.

5.7.43 LE_Signaling_Event (0x32)

Event	Event Code	Event Parameters
LE_Signaling_Event	0x32	SubEvent_Type, SubEvent_Payload

Description:

This event is used to send Bluetooth Low Energy signaling event report/response.

Event Parameters:

SubEvent_Type: (Length: 1 Byte)

Value	Parameter Description
0x00	LE status report

.....continued	
Value	Parameter Description
0x01	LE advertising control report
0x02	LE connection parameter report
0x03	LE connection parameter update RSP
0x04-0xFF	Reserved

SubEvent_Payload: For SubEvent_Type 0x00

Payload Description: Report LE status.

Payload Format: Connection status, GATT service status

Connection Status: (Length: 1 Byte)

Value	Parameter Description
0x00	Standby
0x01	Advertising
0x02	Scanning
0x03	Connected

GATT service status: (Length: 1 Byte)

Value	Parameter Description
Bit 0	0: Transparent data transfer service is inactive 1: Transparent data transfer service is active
Bit 1	0: ANCS service is inactive 1: ANCS service is active
Bit 2~7	Reserved

SubEvent_Payload: For SubEvent_Type 0x01

Payload Description: Report LE Advertising Control status.

Command Status: (Length: 1 Byte)

Value	Parameter Description
0x00	Command Succeeded
0x01-0x3F	Command failed (Refer to BLUETOOTH SPECIFICATION Version 4.0 [Vol 2] Part D, Error Codes on page 339 for a list of error codes and descriptions).

SubEvent_Payload: For SubEvent_Type 0x02

Payload Description: Reports Current LE connection parameters which is set by LE master device.

Payload Format: Connection Interval, Connection Latency, Supervision Timeout

Connection Interval: (Length: 2 Bytes)

Value	Parameter Description
0xXXXX	Ranges from 0x0006 to 0x0C80 (7.5ms to 4s), value for the connection event interval.

Connection Latency: (Length: 2 Bytes)

Value	Parameter Description
0xXXXX	Ranges from 0x0006 to 0x0C80 (7.5ms to 4s), value for this connection.

Supervision Timeout: (Length: 2 Bytes)

Value	Parameter Description
0xXXXX	Ranges from 0x000A to 0x0C80 (100ms to 32s), Supervision timeout for the LE link

SubEvent_Payload: For SubEvent_Type 0x03

Payload Description: Reports the LE connection parameter update response.

Result: (Length: 2 Bytes)

Value	Parameter Description
0x0000	Connection parameters are accepted
0x0001	Connection parameters are rejected
Other	Reserved

5.7.44 Report_nSPK_Link_Status (0x33)

Event	Event Code	Event Parameters
Report_nSPK_Link_Status	0x33	CSB_Connection_State, (Mandatory) CSB_State, (Mandatory) CSB_Group_Number, (Optional) CSB_Address, (Optional)

Description:

This event is used to indicate the state of Enhanced Connectionless Broadcasting used for NSPK link (eCSB –link).

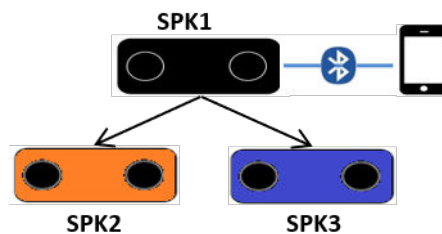

Event Parameters:

CSB_Connection_State: (Length: 1 Byte)

Value	Parameter Description
0x00	The master or slave SPK report eCSB-link non-exists
0x01	The master SPK1 reports SPK1 and connects with SPK2

.....continued	
Value	Parameter Description
0x02	The master SPK1 reports SPK1 and connects with SPK3
0x03	The master SPK1 reports SPK1 and connects with SPK2 and SPK3
0x04	The slave SPK report SPK2 or SPK3 was connected with SPK1
0x05	BTM is Broadcast Master and connects to at least one Broadcast Slave
0x06	BTM is Broadcast Slave and connects to Broadcast Master
0x07	The master SPK reports Timeout while adding more slave SPK in the Broadcast mode

CSB_State: (Length: 1 Byte)

Value	Parameter Description
0x00	eCSB is standby (paging and page_scan are disable)
0x01	eCSB is busy, the eCSB_paging is be postponed (BT paging or SCO)
0x02	eCSB is connecting (the device is in eCSB_page_scan or eCSB_paging mode)
0x03	Creating new eCSB-link is successful
0x04	eCSB-link is loss
0x05	Power on back to NSPK Master
0x06	Power on back to NSPK Slave
0x07	eCSB change from Master connecting to Slave connecting
0x08	eCSB disconnect by NFC
0x09	eCSB has connected to SPK1 and connecting to SPK2

CSB_Group_Number: (Length: 1 Byte)

Value	Parameter Description
0xXX	The number of connected slave speaker. This parameter is only valid when CSB_State is 0x03.

CSB_address: (Length: 6 Bytes)

Value	Parameter Description
0XXXXXXXXXXXX	This parameter indicates the BT Address of connected CSB device. Little endian. This parameter is only valid when CSB_State is 0x03. For example, 0x102030405060 is 60:50:40:30:20:10

5.7.45 Report_nSPK_Vendor_Event (0x34)

Event	Event Code	Event Parameters
Report_nSPK_Vendor_Event	0x34	SPK_index, Payload_length, Payload

Description:

This event is used to report the vendor_event from remote speaker to MCU.

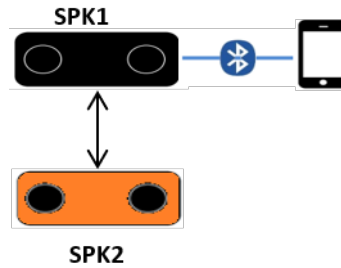

Event Parameters:

SPK_Index: in Concert Mode (Length: 1 Byte)

Value	Parameter Description
0x00	Slave SPK receive vendor command form the master SPK
0xFF	When payload length >9 bytes, BTM always returns 0xFF to MCU

SPK_Index: in Stereo mode (Length: 1 Byte)

Value	Parameter Description
0x01	Slave SPK(SP2) receives vendor command form the master SPK
0x02	Master SPK(SP1) receives vendor command from the slave SPK

Payload_Length: (Length: 2 Byte)

Value	Parameter Description
0xFFFF	Payload length Byte 0: higher byte of length Byte 1: lower byte of length

Note: Slave speaker only send 1 byte (0x01 to 0x1F) data to master, the Payload_length is 0x0001.

Payload: (Length: N Bytes)

Value	Parameter Description
0xFFFFFFFF	Vendor command from Master SPK or Vendor command from Slave SPK (only send 1 byte (0x01to 0x1F) data)

5.7.46 Report_nSPK_Audio_Setting (0x35)

Event	Event Code	Event Parameters
Report_nSPK_Audio_Setting	0x35	Audio_Effect_Type, Audio_Effect_Value

Description:

This event is used for Slave SPK to report current synced audio setting while Master SPK uses command 0x2C nSPK_Sync_Audio_Effect.

Event Parameters:

Audio_Effect_Type: (Length: 1 Byte)

Value	Parameter Description
0xXX	Vendor defined audio effect type

Audio_Effect_Value: (Length: 1 Byte)

Value	Parameter Description
0xXX	Audio effect value

5.7.47 Report_Sound_Effect_Status (0x36)

Event	Event Code	Event Parameters
Report_Sound_Effect_Status	0x36	Sound_Type, Sound_Status

Description:

This event is used to report sound effect status.

Event Parameters:

Sound_Type: (Length: 1 Byte)

Value	Parameter Description
0x00	Audio effect
0x01	3D effect
0x02	RX NR
0x03	TX NR
others	Reserved

Sound_Status: (Length: 1 Byte)

Value	Parameter Description
0xXX	Sound status

5.7.48 Report_Vendor_EEPROM_Data (0x37)

Event	Event Code	Event Parameters
Report_Vendor_EEPROM_Data	0x37	Parameter

Description:

This event is used to report Vendor EEPROM data.

Event Parameters:

Parameter: (Length: 1 Byte)

Value	Parameter Description
0xXX	Vendor EEPROM data

5.7.49 Report_IC_Ver_Info (0x38)

Event	Event Code	Event Parameters
Report_IC_Ver_Info	0x38	Body_Version, Rom_Version, Rom_Sub_Version, Segment, EEPROM, Table_Version, EEPROM_Table_Sub_Version, DSP_Version

Description:

This event is used to report IC Version information.

Event Parameters:

Body_Version: (Length:14 Bytes)

Value	Parameter Description
0xXX	Body version

Rom_Version: (Length: 1 Byte)

Value	Parameter Description
0xXX	ROM version

Rom_Sub_Version: (Length: 1 Byte)

Value	Parameter Description
0xXX	ROM sub-version

Segment: (Length: 1 Byte)

Value	Parameter Description
0xXX	Segment

EEPROM_Table_Version: (Length: 1 Byte)

Value	Parameter Description
0xXX	EEPROM table version

EEPROM_Table_Sub_Version: (Length: 1 Byte)

Value	Parameter Description
0xXX	EEPROM table sub-version

DSP_Version: (Length: 2 Bytes)

Value	Parameter Description
0xXX	DSP Version

5.7.50 REPORT_LE_GATT_EVENT (0x39)

Event	Event Code	Event Parameters
REPORT_LE_GATT_EVENT	0x39	Sub_Event_Type, Parameter

Description:

This event indicates to the host about the GATT events from the remote device and responses for local GATT commands. This event contains the sub event for specific GATT events. The sub events are detailed as below:

Note: The handle and UUID data is reported in reverse byte order.

5.7.50.1 Client_write_char_value (0x00)

This event is used to inform MCU that GATT Client has written a Characteristic Value to DSPK.

Event	Sub-Event Code	Event Parameters
Client_Write_Characteristic_Value	0x00	Connection_Handle, Characteristic_Value_Handle, Characteristic_Value

Event Parameters:

Connection_Handle: (Length: 1 Byte)

Value	Parameter Description
0xXX	Connection handle

Characteristic_Value_Handle: (Length: 2 Bytes)

Value	Parameter Description
0xXX	Characteristic value handle

Characteristic_Value: (Length: N Bytes)

Value	Parameter Description
0xXX	Characteristic value

5.7.50.2 Read_Local_Char_Value_Res (0x01)

This event is used to report local characteristic value to host. This event is triggered in response to any of the below commands.

- Read_Local_Characteristic_Value

Event	Sub-Event Code	Event Parameters
Read_Local_Char_Value_Res	0x01	Connection_Handle, Characteristic_Value_Handle, Characteristic_Value

Event Parameters:

Connection_Handle: (Length: 1 Byte)

Value	Parameter Description
0xXX	Connection handle

Characteristic_Value_Handle: (Length: 2 Bytes)

Value	Parameter Description
0xXX	Characteristic value handle

Characteristic_Value: (Length: N Bytes)

Value	Parameter Description
0xXX	Characteristic value

5.7.50.3 Discover_All_Primary_Services_Res (0x02)

This event is used to report a list of all primary services to host. This event is triggered in response to any of the below commands.

- Read_Local_All_Primary_Services

Event	Sub-Event Code	Event Parameters
Discover_All_Primary_Services_Res	0x02	Connection_Handle, Attribute_Data

Event Parameters:

Connection_Handle: (Length: 1 Byte)

Value	Parameter Description
0xXX	Connection handle

Attribute_Data: Length: 6 to 20 Bytes

The Attribute Data field is comprised of a list of attribute data.

Length	Start Group Handle	End Group Handle	Service UUID
1 Byte	2 Bytes	2 Bytes	(Length -4) Bytes

5.7.50.4 Discover_Specific_Primary_Service_Characteristics_Res (0x03)

This event is used to report a list of all characteristics of a specific service to host. This event is triggered in response to any of the below commands.

- Read_Local_Specific_Primary_Service

Event	Sub-Event Code	Event Parameters
Discover_Specific_Primary_Service_Characteristics_Res	0x03	Connection_Handle, Length, Attribute_Data

Event Parameters:

Connection_Handle: (Length: 1 Byte)

Value	Parameter Description
0xXX	Connection handle

Length: (Length: 1 Byte)

Value	Parameter Description
0xXX	The size of each attribute handle-value pair

Attribute_Data: (Length: 2 to 18 Bytes)

The Attribute Data field is comprised of a list of attribute handle and value pairs for characteristic declaration.

Attribute Handle	Attribute Value
2 Bytes	(Length -2) Bytes

Attribute Value of Characteristic Declaration:

Attribute Value		
Characteristic Properties	Characteristic Value Attribute Handle (2 Bytes)	Characteristic UUID (2 or 16 Bytes)

Properties	Value
Broadcast	0x01
Read	0x02
Write Without Response	0x04
Write	0x08
Notify	0x10
Indicate	0x20
Authenticated Signed Writes	0x40
Extended Properties	0x80

5.7.50.5 Discover_All_Characteristic_Descriptors_Res (0x04)

This event is used to report a list of all characteristic descriptors of a specific service to host. This event is triggered in response to any of the below commands.

- Read_Local_Specific_Primary_Service

Event	Sub-Event Code	Event Parameters
Discover_All_Characteristic_Descriptors_Res	0x04	Connection_Handle, Format, Information_Data

Event Parameters:

Connection_Handle: (Length: 1 Byte)

Value	Parameter Description
0xXX	Connection handle

Format: (Length: 1 Byte)

Value	Parameter Description
0x01	A list of 1 or more handles with their 16-bit Bluetooth UUIDs
0x02	A list of 1 or more handles with their 128-bit UUIDs

Information_Data: Length: 4 to 20 Bytes

The information data is comprised of a list of data defined in the following tables depending on the value chosen for the format.

Handle	16-bit Bluetooth UUID
2 Bytes	2 Bytes

Format 0x01-handle and 16-bit Bluetooth UUIDs

Handle	128-bit Bluetooth UUID
2 Octets	16 Octets

Format 0x02-handle and 128-bit UUIDs

5.7.50.6 Get_Att_MTU_Size_Res (0x05)

This event is used to report the Att MTU size to host. This event is triggered in response to the following command.

5.7.50.7 Get_Att_MTU_Size

Event	Sub-Event Code	Event Parameters
Get_Att_MTU_Size_Res	0x05	Att_MTU_Size

Event Parameters:

Att_MTU_Size: (Length: 1 Byte)

Value	Parameter Description
0xXX	Att MTU Size

5.7.51 Report_BTM_Link_Mode (0x3A)

Event	Event Code	Event Parameters
Report_BTM_Link_Mode	0x3A	Link_Mode_Value, CSB_Group_Number

Description:

This event is used to report the last link mode to MCU.

Event Parameters:

Link_Mode_Value: (Length: 1 Byte)

Value	Parameter Description
0x00	Single mode
0x01	Multipoint
0x02	NSPK master with CSB_Group_Number parameter

.....continued	
Value	Parameter Description
0x03	NSPK slave
0x04	Broadcast Master with CSB_Group_Number parameter
0x05	Broadcast slave

CSB_Group_Number: (Length: 1 Byte)

Value	Parameter Description
0xXX	The number of connected slave speaker. This parameter is only valid when CSB_State is 0x03.

5.7.52 DSP_Dedicated_Event (0x3B)

Event	Event Code	Event Parameters
DSP_Dedicated_Event	0x3B	SubEvent Type, SubEvent Payload length, SubEvent Payload

Description:

This event is used to report dedicated data of DSP.

Event Parameters:

SubEvent Type: (Length: 1 Byte)

Value	SubEvent Type Description
0x00	Send DSP Metadata to customer DSP code. MCU/APP can send data to DSP with an unfixed data length
0x01	Customer DSP code uploads DSP metadata. MCU/APP can get data from DSP with an unfixed data length
0x02-0xFF	Reserved

SubEvent Payload Length: (Length: 1 Byte)

Value	SubEvent Type Description
0~255	SubEvent payload length

SubEvent Payload: (Length: N Bytes)

Value	SubEvent Payload Description
0xXX	SubEvent payload

5.7.53 Report_nSPK_MISC_Event (0x3C)

Event	Event Code	Event Parameters
Report_nSPK_MISC_Event	0x3C	Type, Parameters

Description:

This event is used to report nSPK MISC event (can be used by customer to report some special event).

Event Parameters:

Type: (Length: 1 Byte)

Value	Type Description
0x00	nSPK group status
0x01-0xFF	Reserved

Type = 0

Model Type: (Length: 1 Byte)

Value	Parameters Description
0	Same model
1	Different model

Group ID: (Length: 4 Bytes)

Value	SubEvent Payload Description
0xNNNNNNNN	SHA1 of Master's BD_ADDR

Number of Group: (Length: 1 Byte)

Value	SubEvent Payload Description
0-255	Number of group

5.7.54 Report_nSPK_Exchange_Link_info (0x3D)

Event	Event Code	Event Parameters
Report_nSPK_Exchange_Link_Info	0x3D	Exchanged_data

Description:

This event is used to report the exchanged data of CSB link creation. It will be reported after CSB link is connected.

Event Parameters:

Exchanged_data (Size : 7 Bytes)

Value	SubEvent Type Description
0xNN	Model ID
0xNN	Model number
0xNN	Color
0xNNNNNNNN	Four bytes unique ID

5.7.55 Report_Customized_Information (0x3E)

Event	Event Code	Event Parameters
Report_Customized_Information	0x3E	payload_type payload

Description:

This event is used to report the specified information for customization.

Event Parameters:

payload_type (Size : 1 Bytes)

Value	SubEvent Type Description
0x00	Report unique ID
Others	Reserved

payload_type = 0x00 Unique ID : payload (Size : 4 Bytes)

Value	SubEvent Type Description
0xNNNNNNNN	4 byte unique ID

5.7.56 Report_CSB_CLK (0x3F)

Event	Event Code	Event Parameters
Report_CSB_CLK	0x3F	BT Clock

Description:

This event is used to report the BT CLOCK in CSB link. The BT clock is latched if MCU pulls up the CSB_CLK_LATCH_PIN (P2_7).

Event Parameters:

Bt_clock_data: (Length: 16 Bytes)

Value	SubEvent Type Description
0xNNNN	2 bytes data, high byte is MSB byte

Example:

Received raw data "0x3F 0x12 0x34", the "0x34" is the MSB of BT_CLOCK, "0x12" is the LSB of BT_CLOCK.

5.7.57 Report_Read_Feature_List_Reply (0x40)

Event	Event Code	Event Parameters
Report_Read_Feature_List_Reply	0x40	Feature0, Feature1, Feature2, Feature3

Description:

This event is used to reply the Read_Feature_List command to indicate the supported features.

Event Parameters:

Feature0: (Length: 1 Byte)

Value	Parameter Description
0xXX	1 indicates supported; 0 indicates non-supported Bit0: Stereo Mode Bit1: Concert Mode Bit2: Embedded Application Mode Bit3–7: Reserved

Feature1: (Length: 1 Byte)

Value	Parameter Description
0xXX	Reserved

Feature2: (Length: 1 Byte)

Value	Parameter Description
0xXX	Reserved

Feature3: (Length: 1 Byte)

Value	Parameter Description
0xXX	Reserved

5.7.58 REPORT_TEST_RESULT_REPLY (0x41)

Event	Event Code	Event Parameters
REPORT_TEST_RESULT_REPLY	0x41	Opcode, Status

Description:

This event is used to report the test result of the UART_CMD_TEST_DEVICE.

Event Parameters:

Opcode: (Length: 1 Byte)

Value	Parameter Description
0x00	CP test result

Status: (Length: 1 Byte)

Value	Parameter Description
0x00	Success
0x01	Error

5.7.59 Report_Read_EEPROM_Data (0x42)

Event	Event Code	Event Parameters
Report_Read_EEPROM_Data	0x42	Parameter

Description:

This event is used to report the EEPROM data by sending the read EEPROM data command (0x3C).

Event Parameters:

Parameter: (Length: 1 to 16 Bytes)

Value	Parameter Description
0xXX...	EEPROM data

5.7.60 PBAPC_Event (0x43)

Event	Event Code	Event Parameters	Return Event
PBAP_Client_Event	0x43	Type, Total_Length, Payload_Length, Payload (Sub_EventCode + Parameters)	

Description:

This event is used to send PBAP related event to host MCU.

Event Parameters:

Type: (Length: 1 Byte)

Value	Parameter Description
0x00	Single packet
0x01	Fragmented start packet
0x02	Fragmented continue packet
0x03	Fragmented end packet

Total_Length: (Length: 2 Bytes)

Value	Parameter Description
0xXXXX	Total payload length

Payload_Length: (Length: 2 Bytes)

Value	Parameter Description
0xXXXX	Payload length in this packet

Payload: (Length: N Bytes)

Value	Parameter Description
0xXXXX...	Payload

The detailed definition of payload is described in the following sections.

5.7.60.1 PBAP_Session_Opened

Event	Sub Event Code	Event Parameters
PBAP_Session_Opened	0x00	Device_Identifier, Status

Description:

This event is used to notify the result of PBAP session establishment.

Event Parameters:

Device_Identifier: (Length: 1 Byte)

Value	Parameter Description
0xXX	Device Identifier

Status: (Length: 1 Byte)

Value	Parameter Description
0x00	Connection is established successfully
0x01	Connection is failed

5.7.60.2 PBAP_Session_Disconnected

Event	Sub Event Code	Event Parameters
PBAP_Session_Disconnected	0x01	Device_Identifier

Description:

This event is used to notify the PBAP session is disconnected.

Event Parameters:

Device_Identifier: (Length: 1 Byte)

Value	Parameter Description
0xXX	Device Identifier

5.7.60.3 Pull_Phone_Book_Rsp

Event	Sub Event Code	Event Parameters
Pull_Phone_Book_Response	0x02	Device_Identifier, Is_End_Of_Body, Supp_App_Para_Flag, Phone_Book_Size, New_Missed_Calls, Primary_Ver_Counter, Secondary_Ver_Counter, Database_Id, Object_Data_Body

Description:

This event is used to reply a phone object.

Event Parameters:

Device_Identifier: (Length: 1 Byte)

Value	Parameter Description
0xXX	Device Identifier

Is_End_Of_Body: (Length: 1 Byte)

Value	Parameter Description
0xXX	0: there will be more packets. 1: this is the last data packet.

Supp_App_Para_Flag: (Length: 2 Bytes)

Bit	Parameter Description
Bit7:	Phone_Book_Size_Flag
Bit8:	0: Phone_Book_Size is invalid
Bit 9:	1: Phone_Book_Size is valid
Bit 11	Primary_Ver_Counter_Flag
	0: Primary_Ver_Counter is invalid
	1: Primary_Ver_Counter is valid
	Secdonary_Ver_Counter_Flag
	0: Secdonary_Ver_Counter is invalid
	1: Secdonary_Ver_Counter is valid
	Database_Id_Flag
	0: Database_Id is invalid
	1: Database_Id is valid

Phone_Book_Size: (Length: 2 Byte)

Value	Parameter Description
0XXXXX	This is used in the response when the value of MaxListCount in the request is 0. It shall contain the number of indexes.

New_Missed_Calls: (Length: 1 Byte)

Value	Parameter Description
0xXX	This application parameter shall be used in the response when and only when the phone book object is mch. It indicates the number of missed calls that have been received on the PSE since the last PullPhoneBook request on the mch folder, at the point of the request.

Primary_Ver_Counter: (Length: 16 Byte)

Value	Parameter Description
0xXX	Primary version counter

Secdonary_Ver_Counter: (Length: 16 Byte)

Value	Parameter Description
0xXX	Secondary version counter

Database_Id: (Length: 16 Byte)

Value	Parameter Description
0xXX	Database Id

Object_Data_Body: (Length: XXXX Byte)

Value	Parameter Description
0xXX XX XX	This is vard-listing object data in UTF-8.

5.7.60.4 Pull_Vcard_Listing_Rsp

Event	Sub Event Code	Event Parameters
Pull_Vcard_Listing_Rs	0x03	Device_Identifier, Is_End_Of_Body, Supp_App_Para_Flag, Phone_Book_Size, New_Missed_Calls, Primary_Ver_Counter, Secondary_Ver_Counter, Database_Id, Object_Data_Body

Description:

This event is used to reply the list of Phone Book entries.

Event Parameters:

Device_Identifier: (Length: 1 Byte)

Value	Parameter Description
0xXX	Device Identifier

Is_End_Of_Body: (Length: 1 Byte)

Value	Parameter Description
0xXX	0: there will be more packets. 1: this is the last data packet.

Supp_App_Para_Flag: (Length: 2 Bytes)

Bit	Parameter Description
Bit7:	Phone_Book_Size_Flag
Bit8:	0: Phone_Book_Size is invalid
Bit 9:	1: Phone_Book_Size is valid
Bit 11	Primary_Ver_Counter_Flag
	0: Primary_Ver_Counter is invalid
	1: Primary_Ver_Counter is valid
	Secdonary_Ver_Counter_Flag
	0: Secdonary_Ver_Counter is invalid
	1: Secdonary_Ver_Counter is valid
	Database_Id_Flag
	0: Database_Id is invalid
	1: Database_Id is valid

Phone_Book_Size: (Length: 2 Byte)

Value	Parameter Description
0xFFFF	This is used in the response when the value of MaxListCount in the request is 0. It shall contain the number of indexes.

New_Missed_Calls: (Length: 1 Byte)

Value	Parameter Description
0xFF	This application parameter shall be used in the response when and only when the phone book object is mch. It indicates the number of missed calls that have been received on the PSE since the last PullPhoneBook request on the mch folder, at the point of the request.

Primary_Ver_Counter: (Length: 16 Byte)

Value	Parameter Description
0xFF	Primary version counter

Secdonary_Ver_Counter: (Length: 16 Byte)

Value	Parameter Description
0xFF	Secondary version counter

Database_Id: (Length: 16 Byte)

Value	Parameter Description
0xFF	Database Id

Object_Data_Body: (Length: XXXX Byte)

Value	Parameter Description
0xXX XX XX	This is vard-listing object data in UTF-8.

5.7.60.5 Pull_Vcard_Entry_Rsp

Event	Sub Event Code	Event Parameters
Pull_Vcard_Entry_Res	0x04	Device_Identifier, Is_End_Of_Body, Supp_App_Para_Flag Database_Id, Object_Data_Body

Description:

This event is used to reply a Phone Book entry.

Event Parameters:

Device_Identifier: (Length: 1 Byte)

Value	Parameter Description
0xXX	Device Identifier

Is_End_Of_Body: (Length: 1 Byte)

Value	Parameter Description
0xXX	0: There will be more packets. 1: This is the last data packet.

Supp_App_Para_Flag: (Length: 2 Bytes)

Bit	Parameter Description
Bit 11	Database_Id_Flag 0: Database_Id is invalid 1: Database_Id is valid

Database_Id: (Length: 16 Byte)

Value	Parameter Description
0xXX	Database Id

Object_Data_Body: (Length: XXXX Byte)

Value	Parameter Description
0xXX XX XX ...	This is vCard object data in UTF-8.

5.7.60.6 Set_Phone_Book_Rsp

Event	Sub Event Code	Event Parameters
Set_Phone_Bbook_Res	0x05	Device_Identifier

Description:

This event is used to reply the result of set current folder request.

Event Parameters:

Device_Identifier: (Length: 1 Byte)

Value	Parameter Description
0xXX	Device Identifier

5.7.60.7 Abort_Rsp

Event	Sub Event Code	Event Parameters
Abort_Rsp	0x06	Device_Identifier

Description:

This event is used to reply the result of abort request.

Event Parameters:

Device_Identifier: (Length: 1 Byte)

Value	Parameter Description
0xXX	Device Identifier

5.7.60.8 Error_Rsp

Event	Sub Event Code	Event Parameters
Error_Rsp	0x07	Device_Identifier, Response_Code

Description:

This event is used to reply the result of set current folder request.

Event Parameters:

Device_Identifier: (Length: 1 Byte)

Value	Parameter Description
0xXX	Device Identifier

Response_Code: (Length: 1 Byte)

Value	Parameter Description
0x30	Multiple choices
0x31	Moved permanently
0x32	Moved temporarily
0x33	See other
0x34	Not modified

.....continued	
Value	Parameter Description
0x35	Use proxy
0x40	Bad request
0x41	Unauthorized
0x42	Payment required
0x43	Forbidden
0x44	Not found
0x45	Method not allowed
0x46	Not acceptable
0x47	Proxy authentication required
0x48	Request time out
0x49	Conflict
0x4a	Gone
0x4b	Length required
0x4c	Precondition failed
0x4d	Requested entity too large
0x4e	Request URL too large
0x4f	Unsupported media type
0x50	Internal server error
0x51	Not implemented
0x52	Bad gateway
0x53	Service unavailable
0x54	Gateway timeout
0x55	HTTP version not supported
0x60	Database full
0x61	Database locked

5.7.60.9 Supported_Features

Event	Sub Event Code	Event Parameters
Supported_Features	0x08	Device_Identifier, Supported_Respositories, Supported_Features, Profile_Version

Description:

This event is used to notify information about remote device PBAP supported features

This event is available if profile version is 1.2

Event Parameters:

Device_Identifier: (Length: 1 Byte)

Value	Parameter Description
0xXX	Device Identifier

Supported_Respositories: (Length: 1 Byte)

Value	Parameter Description
Bit 0	Supported Repositories: Local Phonebook
Bit 1	Supported Repositories: SIM card
Bit 2	Supported Repositories: Speed dial
Bit 3	Supported Repositories: Favorites

Supported_Features: (Length: 4 Byte)

Value	Parameter Description
Bit 0	Supported feature: Download
Bit 1	Supported feature: Browsing
Bit 2	Supported feature: Database identifier
Bit 3	Supported feature: Folder version counters
Bit 4	Supported feature: vCard selecting
Bit 5	Supported feature: Enhanced missed calls
Bit 6	Supported feature: X-BT-UCI vCard property
Bit 7	Supported feature: X-BT_UID vCard property
Bit 8	Supported feature: Contact referencing
Bit 9	Supported feature: Default contact image format

Profile_Version: (Length: 2 Byte)

Value	Parameter Description
0xXXXX	The PBAP Version The high byte is Major version, the low byte is Minor version For example, 0x0102 means PBAP 1.2

5.7.61 AVRCP_Browsing_Event (0x44)

Event	Event Code	Event Parameters
AVRCP_Browsing_event	0x44	Type, Total_Length, Payload_Length, Payload (Sub_EventCode + Parameters)

Description:

This event is used to send AVRCP Browsing related event to host MCU.

Event Parameters:

Type: (Length: 1 Byte)

Value	Parameter Description
0x00	Single packet
0x01	Fragmented start packet
0x02	Fragmented continue packet
0x03	Fragmented end packet

Total_Length: (Length: 2 Bytes)

Value	Parameter Description
0xFFFF	Total payload length

Payload_Length: (Length: 2 Bytes)

Value	Parameter Description
0xFFFF	Payload length in this packet

Payload: (Length: N Bytes)

Value	Parameter Description
0xFFFF...	Payload

The detailed definition of payload is described in the following sections.

5.7.61.1 GetFolderItems_Rsp

Event	Sub Event Code	Event Parameters
GetFolderItems_Rsp	0x00	Data_Base_Index, Status, UIDCounter, Items_Num, List_len, ItemList

Description:

This event is used to notify the response of GetFolderItems command ([5.6.54.1 GetFolderItems](#)).

Event Parameters:

Data_Base_Index: (Length: 1 Byte)

Value	Parameter Description
0xFF	Linked device index

Status: (Length: 1 Byte)

Value	Parameter Description
0xFF	The result of the GetFolderItems operation. Refer to 5.7.61.16 Definition of Status Code .

UIDCounter: (Length: 2 Byte)

Value	Parameter Description
0xFFFF	The UID Counter.

Items_Num: (Length: 2 Byte)

Value	Parameter Description
0xFFFF	The number of items returned in this listing.

List_len: (Length: 2 Byte)

Value	Parameter Description
0xFFFF	The length of returned items in this listing.

ItemList: (Length: N Byte)

Value	Parameter Description
0xFF...	The attributes returned with each item shall be the supported attributes from the list provided in the attribute list parameter of the request. Refer to AVRCP Specification [5] for detail information.

5.7.61.2 GetTotalNumberOfItems_Rsp

Event	Sub Event Code	Event Parameters
GetTotalNumberOfItems_Rsp	0x01	Data_Base_Index, Status, UIDCounter, Items_Num

Description:

This event is used to notify the response of GetTotalNumberOfItems command ([5.6.54.2 GetTotalNumberOfItems](#)).

Event Parameters:

Data_Base_Index: (Length: 1 Byte)

Value	Parameter Description
0xFF	Linked device index

Status: (Length: 1 Byte)

Value	Parameter Description
0xFF	The result of the GetTotalNumberOfItems operation. Refer to 5.7.61.16 Definition of Status Code .

UIDCounter: (Length: 2 Byte)

Value	Parameter Description
0xFFFF	The UID Counter.

Items_Num: (Length: 4 Byte)

Value	Parameter Description
0xFFFFFFFF	The number of items in this folder/scope.

5.7.61.3 SetAddressedPlayer_Rsp

Event	Sub Event Code	Event Parameters
SetAddressedPlayer_Rsp	0x02	Data_Base_Index, Response, Status

Description:

This event is used to notify the response of SetAddressedPlayer command ([5.6.54.3 SetAddressedPlayer](#)).

Event Parameters:

Data_Base_Index: (Length: 1 Byte)

Value	Parameter Description
0xFF	Linked device index

Response: (Length: 1 Byte)

Value	Parameter Description
0xFF	Response type: 0x08: Not implement 0x09: Accept 0x0A: Reject 0x0C: Stable 0x0D: Changed 0x0F: Interim

Status: (Length: 1 Byte)

Value	Parameter Description
0xFF	The result of the SetBrowsedPlayer operation. Refer to 5.7.61.16 Definition of Status Code .

5.7.61.4 SetBrowsedPlayer_Rsp

Event	Sub Event Code	Event Parameters
SetBrowsedPlayer_Rsp	0x03	Data_Base_Index, Status, UIDCounter, Items_Num, Char_Set_Id, Folder_Depth, Total_Folder_List_Len, Folder_List

Description:

This event is used to notify the response of SetBrowsedPlayer command ([5.6.54.4 SetBrowsedPlayer](#)).

Event Parameters:

Data_Base_Index: (Length: 1 Byte)

Value	Parameter Description
0xXX	Linked device index

Status: (Length: 1 Byte)

Value	Parameter Description
0xXX	The result of the SetBrowsedPlayer operation. Refer to 5.7.61.16 Definition of Status Code .

UIDCounter: (Length: 2 Byte)

Value	Parameter Description
0xXXXX	The UID Counter.

Items_Num: (Length: 4 Byte)

Value	Parameter Description
0XXXXXXXX	If the SetBrowsedPlayer succeeded, it is the number of items in the current folder. If the SetBrowsedPlayer did not succeed, the value of this parameter shall be ignored.

Char_Set_Id: (Length: 2 Byte)

Value	Parameter Description
0xXXXX	Specifies the character set ID to be displayed on CT.

Folder_Depth: (Length: 1 Byte)

Value	Parameter Description
0xXX	The number of Folder Name Length/Folder Name pairs which follow.

Total_Folder_List_Len: (Length: 2 Byte)

Value	Parameter Description
0xXXXX	Total length of the following Folder Name Length/Folder Name pairs.

Folder_List: (Length: Total_Folder_List_Len Byte)

Value	Parameter Description
0XXXXX...	The list of Folder Name Length/Folder Name pairs. Refer to AVRCP Specification [5] for detail information.

For example, if Folder_Depth = 0x03, Total_Folder_List_Len = 0x0C, Folder_List = 0x00 01 41 00 02 42 43 00 03 44 45 46,

It means there are three Folder Name Length/Folder Name pairs:

Folder_Depth	Total_Folder_List_Le n	Folder Name Length	Folder Name	Folder Name Length	Folder Name	Folder Name Length	Folder Name
0x03	0x0C	0x0001	0x41 (‘A’)	0x0002	0x42 0x43 (‘BC’)	0x0003	0x44 0x45 0x46 (‘DEF’)

5.7.61.5 ChangePath_Rsp

Event	Sub Event Code	Event Parameters
ChangePath_Rsp	0x04	Data_Base_Index, Status, Items_Num

Description:

This event is used to notify the response of ChangePath command ([5.6.54.5 ChangePath](#)).

Event Parameters:

Data_Base_Index: (Length: 1 Byte)

Value	Parameter Description
0xXX	Linked device index

Status: (Length: 1 Byte)

Value	Parameter Description
0xXX	The result of the ChangePath operation. Refer to 5.7.61.16 Definition of Status Code .

Items_Num: (Length: 4 Byte)

Value	Parameter Description
0XXXXXXXX	If the ChangePath succeeded, it is the number of items in the folder which has been changed.

5.7.61.6 GetItemAttributes_Rsp

Event	Sub Event Code	Event Parameters
GetItemAttributes Rsp	0x05	Data_Base_Index, Status, Attr_Num, Total_Attr_List_Len, Attr_List

Description:

This event is used to notify the response of GetItemAttributes command ([5.6.54.6 GetItemAttributes](#)).

Event Parameters:

Data_Base_Index: (Length: 1 Byte)

Value	Parameter Description
0xXX	Linked device index

Status: (Length: 1 Byte)

Value	Parameter Description
0xXX	The result of the GetItemAttributes operation. Refer to 5.7.61.16 Definition of Status Code .

Attr_Num: (Length: 1 Byte)

Value	Parameter Description
0xXX	The number of Attribute Value Entries in the following Attribute Value Entry list.

Total_Attr_List_Len: (Length: 2 Byte)

Value	Parameter Description
0xXXXX	The total length of attributes.

Attr_List: (Length: Total_Attr_List_Len)

Value	Parameter Description
0xXXXX...	Attribute Value Entry list. Refer to AVRCP Specification [5] for detail information.

For example, if Item_Num = 0x03, it means there are three Attributes :

		Attribute 1				Attribute 2				Attribute 3			
Attr_Num (0x03)	Total_Attr_List_Len	Attr ID	Char Set ID	Attr value length	Attr value	Attr ID	Char Set ID	Attr value length	Attr value	Attr ID	Char Set ID	Attr value length	Attr value

5.7.61.7 Search_Rsp

Event	Sub Event Code	Event Parameters
Search_Rsp	0x06	Data_Base_Index, Status, UIDCounter, Items_Num

Description:

This event is used to notify the response of Search command ([5.6.54.7 Search](#)).

Event Parameters:

Data_Base_Index: (Length: 1 Byte)

Value	Parameter Description
0xXX	Linked device index

Status: (Length: 1 Byte)

Value	Parameter Description
0xXX	The result of the GetItemAttributes operation. Refer to 5.7.61.16 Definition of Status Code .

UIDCounter: (Length: 2 Byte)

Value	Parameter Description
0xXXXX	The UID counter.

Items_Num: (Length: 4 Byte)

Value	Parameter Description
0XXXXXXXX	The number of media element items found in the search.

5.7.61.8 PlayItem_Rsp

Event	Sub Event Code	Event Parameters
PlayItem_Rsp	0x07	Data_Base_Index, Response, Status

Description:

This event is used to notify the response of PlayItem command ([5.6.54.8 PlayItem](#)).

Event Parameters:

Data_Base_Index: (Length: 1 Byte)

Value	Parameter Description
0xXX	Linked device index

Response: (Length: 1 Byte)

Value	Parameter Description
0xXX	Response type: 0x08: Not implement 0x09: Accept 0x0A: Reject 0x0C: Stable 0x0D: Changed 0x0F: Interim

Status: (Length: 1 Byte)

Value	Parameter Description
0xXX	The result of the GetItemAttributes operation. Refer to 5.7.61.16 Definition of Status Code .

5.7.61.9 AddToNowPlaying_Rsp

Event	Sub Event Code	Event Parameters
AddToNowPlaying_Rsp	0x08	Data_Base_Index, Response, Status

Description:

This event is used to notify the response of AddToNowPlaying command ([5.6.54.9 AddToNowPlaying](#)).

Event Parameters:

Data_Base_Index: (Length: 1 Byte)

Value	Parameter Description
0xXX	Linked device index

Response: (Length: 1 Byte)

Value	Parameter Description
0xXX	Response type: 0x08: Not implement 0x09: Accept 0x0A: Reject 0x0C: Stable 0x0D: Changed 0x0F: Interim

Status: (Length: 1 Byte)

Value	Parameter Description
0xXX	The result of the GetItemAttributes operation. Refer to 5.7.61.16 Definition of Status Code .

5.7.61.10 GeneralReject_Rsp

Event	Sub Event Code	Event Parameters
GeneralReject_Rsp	0x09	Data_Base_Index, Reject_Reason

Description:

This event is used to notify the response of General Reject.

Event Parameters:

Data_Base_Index: (Length: 1 Byte)

Value	Parameter Description
0xXX	Linked device index

Reject_Reason: (Length: 1 Byte)

Value	Parameter Description
0xXX	The reason for the General Reject. Refer to 5.7.61.16 Definition of Status Code .

5.7.61.11 NowPlayingContentChanged_Notify

Event	Sub Event Code	Event Parameters
NowPlayingContentChanged_Notify	0x0A	Data_Base_Index, Response

Description:

This event is used to notify the content of the NowPlaying folder for the Addressed Player is changed

Event Parameters:

Data_Base_Index: (Length: 1 Byte)

Value	Parameter Description
0xXX	Linked device index

Response: (Length: 1 Byte)

Value	Parameter Description
0xXX	Response. Refer to 5.7.61.17 Definition of AVRCP Response .

5.7.61.12 AvailablePlayerChanged_Notify

Event	Sub Event Code	Event Parameters
NowPlayingContentChanged_Notify	0x0B	Data_Base_Index, Response

Description:

This event is used to notify if a new player becomes available to be addressed (for instance started, or installed) or if a player ceases to be available.

Event Parameters:

Data_Base_Index: (Length: 1 Byte)

Value	Parameter Description
0xXX	Linked device index.

Response: (Length: 1 Byte)

Value	Parameter Description
0xXX	Response. Refer to 5.7.61.17 Definition of AVRCP Response .

5.7.61.13 AddressedPlayerChanged_Notify

Event	Sub Event Code	Event Parameters
AddressedPlayerChanged_Notify	0x0C	Data_Base_Index, Response, PlayerId, UIDCounter

Description:

This event is used to notify the Addressed Player is changed.

Event Parameters:

Data_Base_Index: (Length: 1 Byte)

Value	Parameter Description
0xXX	Linked device index.

Response: (Length: 1 Byte)

Value	Parameter Description
0xXX	Response. Refer to 5.7.61.17 Definition of AVRCP Response .

PlayerId: (Length: 1 Byte)

Value	Parameter Description
0xXX	Unique media player Id.

UIDCounter: (Length: 2 Byte)

Value	Parameter Description
0XXXXX	The UID counter.

5.7.61.14 UIDsChanged_Notify

Event	Sub Event Code	Event Parameters
UIDsChanged_Notify	0x0D	Data_Base_Index, Response, UIDCounter

Description:

This event is used to notify the UIDs are changed on TG.

Event Parameters:

Data_Base_Index: (Length: 1 Byte)

Value	Parameter Description
0xXX	Linked device index.

Response: (Length: 1 Byte)

Value	Parameter Description
0xXX	Response. Refer to 5.7.61.17 Definition of AVRCP Response .

UIDCounter: (Length: 2 Byte)

Value	Parameter Description
0XXXXX	The UID Counter.

5.7.61.15 ConnectionStatus

Event	Sub Event Code	Event Parameters
ConnectionStatus	0x0E	Data_Base_Index, Status

Description:

This event is used to notify the AVRCP browsing connection status.

Event Parameters:

Data_Base_Index: (Length: 1 Byte)

Value	Parameter Description
0xXX	Linked device index.

Status: (Length: 1 Byte)

Value	Parameter Description
0x00	AVRCP browsing channel is disconnected.
0x01	AVRCP browsing channel is connected.

5.7.61.16 Definition of Status Code

Status: (Length: 1 Byte)

Value	Parameter Description
0x00	Invalid command
0x01	Invalid parameter
0x02	Parameter content error
0x03	Internal error
0x04	Operation completed without error
0x05	UID changed
0x06	Reserved
0x07	Invalid direction
0x08	Not a directory
0x09	Does not exist
0x0A	Invalid scope
0x0B	Range out of bounds
0x0C	Folder item is not playable
0x0D	Media in use
0x0E	Now playing list full
0x0F	Search not supported

.....continued	
Value	Parameter Description
0x10	Search in progress
0x11	Invalid player Id
0x12	Player not browsable
0x13	Player not addressed
0x14	No valid search results
0x15	No available players
0x16	Addressed player changed

5.7.61.17 Definition of AVRCP Response

Response: (Length: 1 Byte)

Value	Parameter Description
0x08	Not implemented
0x09	Accept
0x0A	Reject
0x0C	Stable
0x0D	Changed
0x0F	Interim

6. Document Revision History

Revision	Date	Section	Description
A	07/2019	Document	Initial Release

The Microchip Website

Microchip provides online support via our website at <http://www.microchip.com/>. This website is used to make files and information easily available to customers. Some of the content available includes:

- **Product Support** – Data sheets and errata, application notes and sample programs, design resources, user's guides and hardware support documents, latest software releases and archived software
- **General Technical Support** – Frequently Asked Questions (FAQs), technical support requests, online discussion groups, Microchip design partner program member listing
- **Business of Microchip** – Product selector and ordering guides, latest Microchip press releases, listing of seminars and events, listings of Microchip sales offices, distributors and factory representatives

Product Change Notification Service

Microchip's product change notification service helps keep customers current on Microchip products. Subscribers will receive email notification whenever there are changes, updates, revisions or errata related to a specified product family or development tool of interest.

To register, go to <http://www.microchip.com/pcn> and follow the registration instructions.

Customer Support

Users of Microchip products can receive assistance through several channels:

- Distributor or Representative
- Local Sales Office
- Embedded Solutions Engineer (ESE)
- Technical Support

Customers should contact their distributor, representative or ESE for support. Local sales offices are also available to help customers. A listing of sales offices and locations is included in this document.

Technical support is available through the website at: <http://www.microchip.com/support>

Microchip Devices Code Protection Feature

Note the following details of the code protection feature on Microchip devices:

- Microchip products meet the specification contained in their particular Microchip Data Sheet.
- Microchip believes that its family of products is one of the most secure families of its kind on the market today, when used in the intended manner and under normal conditions.
- There are dishonest and possibly illegal methods used to breach the code protection feature. All of these methods, to our knowledge, require using the Microchip products in a manner outside the operating specifications contained in Microchip's Data Sheets. Most likely, the person doing so is engaged in theft of intellectual property.
- Microchip is willing to work with the customer who is concerned about the integrity of their code.
- Neither Microchip nor any other semiconductor manufacturer can guarantee the security of their code. Code protection does not mean that we are guaranteeing the product as "unbreakable."

Code protection is constantly evolving. We at Microchip are committed to continuously improving the code protection features of our products. Attempts to break Microchip's code protection feature may be a violation of the Digital Millennium Copyright Act. If such acts allow unauthorized access to your software or other copyrighted work, you may have a right to sue for relief under that Act.

Legal Notice

Information contained in this publication regarding device applications and the like is provided only for your convenience and may be superseded by updates. It is your responsibility to ensure that your application meets with

your specifications. MICROCHIP MAKES NO REPRESENTATIONS OR WARRANTIES OF ANY KIND WHETHER EXPRESS OR IMPLIED, WRITTEN OR ORAL, STATUTORY OR OTHERWISE, RELATED TO THE INFORMATION, INCLUDING BUT NOT LIMITED TO ITS CONDITION, QUALITY, PERFORMANCE, MERCHANTABILITY OR FITNESS FOR PURPOSE. Microchip disclaims all liability arising from this information and its use. Use of Microchip devices in life support and/or safety applications is entirely at the buyer's risk, and the buyer agrees to defend, indemnify and hold harmless Microchip from any and all damages, claims, suits, or expenses resulting from such use. No licenses are conveyed, implicitly or otherwise, under any Microchip intellectual property rights unless otherwise stated.

Trademarks

The Microchip name and logo, the Microchip logo, Adaptec, AnyRate, AVR, AVR logo, AVR Freaks, BesTime, BitCloud, chipKIT, chipKIT logo, CryptoMemory, CryptoRF, dsPIC, FlashFlex, flexPWR, HELDO, IGLOO, JukeBlox, KeeLoq, Kleer, LANCheck, LinkMD, maXStylus, maXTouch, MediaLB, megaAVR, Microsemi, Microsemi logo, MOST, MOST logo, MPLAB, OptoLyzer, PackeTime, PIC, picoPower, PICSTART, PIC32 logo, PolarFire, Prochip Designer, QTouch, SAM-BA, SenGenuity, SpyNIC, SST, SST Logo, SuperFlash, Symmetricom, SyncServer, Tachyon, TempTrackr, TimeSource, tinyAVR, UNI/O, Vectron, and XMEGA are registered trademarks of Microchip Technology Incorporated in the U.S.A. and other countries.

APT, ClockWorks, The Embedded Control Solutions Company, EtherSynch, FlashTec, Hyper Speed Control, HyperLight Load, IntelliMOS, Libero, motorBench, mTouch, Powermite 3, Precision Edge, ProASIC, ProASIC Plus, ProASIC Plus logo, Quiet-Wire, SmartFusion, SyncWorld, Temux, TimeCesium, TimeHub, TimePictra, TimeProvider, Vite, WinPath, and ZL are registered trademarks of Microchip Technology Incorporated in the U.S.A.

Adjacent Key Suppression, AKS, Analog-for-the-Digital Age, Any Capacitor, AnyIn, AnyOut, BlueSky, BodyCom, CodeGuard, CryptoAuthentication, CryptoAutomotive, CryptoCompanion, CryptoController, dsPICDEM, dsPICDEM.net, Dynamic Average Matching, DAM, ECAN, EtherGREEN, In-Circuit Serial Programming, ICSP, INICnet, Inter-Chip Connectivity, JitterBlocker, KleerNet, KleerNet logo, memBrain, Mindi, MiWi, MPASM, MPF, MPLAB Certified logo, MPLIB, MPLINK, MultiTRAK, NetDetach, Omniscient Code Generation, PICDEM, PICDEM.net, PICkit, PICtail, PowerSmart, PureSilicon, QMatrix, REAL ICE, Ripple Blocker, SAM-ICE, Serial Quad I/O, SMART-I.S., SQI, SuperSwitcher, SuperSwitcher II, Total Endurance, TSHARC, USBCheck, VariSense, ViewSpan, WiperLock, Wireless DNA, and ZENA are trademarks of Microchip Technology Incorporated in the U.S.A. and other countries.

SQTP is a service mark of Microchip Technology Incorporated in the U.S.A.

The Adaptec logo, Frequency on Demand, Silicon Storage Technology, and Symmcom are registered trademarks of Microchip Technology Inc. in other countries.

GestIC is a registered trademark of Microchip Technology Germany II GmbH & Co. KG, a subsidiary of Microchip Technology Inc., in other countries.

All other trademarks mentioned herein are property of their respective companies.

© 2019, Microchip Technology Incorporated, Printed in the U.S.A., All Rights Reserved.

ISBN: 978-1-5224-4806-8

Quality Management System

For information regarding Microchip's Quality Management Systems, please visit <http://www.microchip.com/quality>.

Worldwide Sales and Service

AMERICAS	ASIA/PACIFIC	ASIA/PACIFIC	EUROPE
<p>Corporate Office 2355 West Chandler Blvd. Chandler, AZ 85224-6199 Tel: 480-792-7200 Tel: 480-792-7277 Technical Support: http://www.microchip.com/support Web Address: http://www.microchip.com</p> <p>Atlanta Duluth, GA Tel: 678-957-9614 Fax: 678-957-1455</p> <p>Austin, TX Tel: 512-257-3370</p> <p>Boston Westborough, MA Tel: 774-760-0087 Fax: 774-760-0088</p> <p>Chicago Itasca, IL Tel: 630-285-0071 Fax: 630-285-0075</p> <p>Dallas Addison, TX Tel: 972-818-7423 Fax: 972-818-2924</p> <p>Detroit Novi, MI Tel: 248-848-4000</p> <p>Houston, TX Tel: 281-894-5983</p> <p>Indianapolis Noblesville, IN Tel: 317-773-8323 Fax: 317-773-5453 Tel: 317-536-2380</p> <p>Los Angeles Mission Viejo, CA Tel: 949-462-9523 Fax: 949-462-9608 Tel: 951-273-7800</p> <p>Raleigh, NC Tel: 919-844-7510</p> <p>New York, NY Tel: 631-435-6000</p> <p>San Jose, CA Tel: 408-735-9110 Tel: 408-436-4270</p> <p>Canada - Toronto Tel: 905-695-1980 Fax: 905-695-2078</p>	<p>Australia - Sydney Tel: 61-2-9868-6733</p> <p>China - Beijing Tel: 86-10-8569-7000</p> <p>China - Chengdu Tel: 86-28-8665-5511</p> <p>China - Chongqing Tel: 86-23-8980-9588</p> <p>China - Dongguan Tel: 86-769-8702-9880</p> <p>China - Guangzhou Tel: 86-20-8755-8029</p> <p>China - Hangzhou Tel: 86-571-8792-8115</p> <p>China - Hong Kong SAR Tel: 852-2943-5100</p> <p>China - Nanjing Tel: 86-25-8473-2460</p> <p>China - Qingdao Tel: 86-532-8502-7355</p> <p>China - Shanghai Tel: 86-21-3326-8000</p> <p>China - Shenyang Tel: 86-24-2334-2829</p> <p>China - Shenzhen Tel: 86-755-8864-2200</p> <p>China - Suzhou Tel: 86-186-6233-1526</p> <p>China - Wuhan Tel: 86-27-5980-5300</p> <p>China - Xian Tel: 86-29-8833-7252</p> <p>China - Xiamen Tel: 86-592-2388138</p> <p>China - Zhuhai Tel: 86-756-3210040</p>	<p>India - Bangalore Tel: 91-80-3090-4444</p> <p>India - New Delhi Tel: 91-11-4160-8631</p> <p>India - Pune Tel: 91-20-4121-0141</p> <p>Japan - Osaka Tel: 81-6-6152-7160</p> <p>Japan - Tokyo Tel: 81-3-6880-3770</p> <p>Korea - Daegu Tel: 82-53-744-4301</p> <p>Korea - Seoul Tel: 82-2-554-7200</p> <p>Malaysia - Kuala Lumpur Tel: 60-3-7651-7906</p> <p>Malaysia - Penang Tel: 60-4-227-8870</p> <p>Philippines - Manila Tel: 63-2-634-9065</p> <p>Singapore Tel: 65-6334-8870</p> <p>Taiwan - Hsin Chu Tel: 886-3-577-8366</p> <p>Taiwan - Kaohsiung Tel: 886-7-213-7830</p> <p>Taiwan - Taipei Tel: 886-2-2508-8600</p> <p>Thailand - Bangkok Tel: 66-2-694-1351</p> <p>Vietnam - Ho Chi Minh Tel: 84-28-5448-2100</p>	<p>Austria - Wels Tel: 43-7242-2244-39 Fax: 43-7242-2244-393</p> <p>Denmark - Copenhagen Tel: 45-4450-2828 Fax: 45-4485-2829</p> <p>Finland - Espoo Tel: 358-9-4520-820</p> <p>France - Paris Tel: 33-1-69-53-63-20 Fax: 33-1-69-30-90-79</p> <p>Germany - Garching Tel: 49-8931-9700</p> <p>Germany - Haan Tel: 49-2129-3766400</p> <p>Germany - Heilbronn Tel: 49-7131-72400</p> <p>Germany - Karlsruhe Tel: 49-721-625370</p> <p>Germany - Munich Tel: 49-89-627-144-0 Fax: 49-89-627-144-44</p> <p>Germany - Rosenheim Tel: 49-8031-354-560</p> <p>Israel - Ra'anana Tel: 972-9-744-7705</p> <p>Italy - Milan Tel: 39-0331-742611 Fax: 39-0331-466781</p> <p>Italy - Padova Tel: 39-049-7625286</p> <p>Netherlands - Drunen Tel: 31-416-690399 Fax: 31-416-690340</p> <p>Norway - Trondheim Tel: 47-72884388</p> <p>Poland - Warsaw Tel: 48-22-3325737</p> <p>Romania - Bucharest Tel: 40-21-407-87-50</p> <p>Spain - Madrid Tel: 34-91-708-08-90 Fax: 34-91-708-08-91</p> <p>Sweden - Gothenberg Tel: 46-31-704-60-40</p> <p>Sweden - Stockholm Tel: 46-8-5090-4654</p> <p>UK - Wokingham Tel: 44-118-921-5800 Fax: 44-118-921-5820</p>