HDMI Loopback Design

Introduction

This document describes how to run video loopback design using the PolarFire® Video Kit with a video source, display, HDMI TX port, and HDMI RX port. The demo design features a fully-integrated solution developed using Microchip's Libero® System-on-Chip (SoC) software that enables you to evaluate PolarFire FPGA in smart embedded vision applications and to build prototypes, quickly. For more information about Smart Embedded Vision IPs, see [Smart Embedded Vision](#).

The demo design captures the video and audio from a source using the HDMI 2.0 RX port and decodes the HDMI data as a video and an auxiliary data (audio and control data). The decoded data is then written to the FIFOs before looping back to an external HDMI compliant source or a monitor using the HDMI 2.0 TX port.

The following are the PolarFire Video Kit features:

- 300K LE FPGA (MPF300T-FCG1152)
- HDMI 2.0 TX
- HDMI 2.0 RX
- HDMI 1.4 TX

Table of Contents

| | |
|--|----|
| Introduction..... | 1 |
| 1. Demo Prerequisites | 3 |
| 2. Demo Requirements..... | 4 |
| 3. Design Description..... | 5 |
| 3.1. Hardware Implementation..... | 6 |
| 3.2. I/O Ports..... | 9 |
| 3.3. Clocking Structure..... | 10 |
| 3.4. Reset Structure..... | 10 |
| 4. Setting Up the Demo..... | 12 |
| 4.1. Setting Up the Hardware..... | 12 |
| 4.2. Programming the Device..... | 12 |
| 5. Running the Demo..... | 13 |
| 6. Appendix A : Programming the Device using FlashPro Express..... | 14 |
| 7. Revision History..... | 15 |
| Microchip FPGA Support..... | 16 |
| Microchip Information..... | 16 |
| The Microchip Website..... | 16 |
| Product Change Notification Service..... | 16 |
| Customer Support..... | 16 |
| Microchip Devices Code Protection Feature..... | 16 |
| Legal Notice..... | 17 |
| Trademarks..... | 17 |
| Quality Management System..... | 18 |
| Worldwide Sales and Service..... | 19 |

1. Demo Prerequisites

Before you begin, perform the following steps:

- Download the design files from the following link: www.microchip.com/en-us/application-notes/AN4768.
- Download and install the Libero SoC Design Suite from [Libero SoC Software Downloads](#).

2. Demo Requirements

The following table lists the hardware and software required to run the demo.

Table 2-1. Demo Requirements

| Requirement | Description |
|-----------------------------|--|
| Hardware | |
| PolarFire® video kit | DVP-102-000512-001 REV 1.0 |
| USB A to mini-B cable | Required for FPGA programming |
| HDMI Display | 1920 x 1080 (60 Hz) resolution |
| Two HDMI cables | HDMI A male-to-male cable |
| Power Adapter | 12V, 5A |
| Software | |
| Program_Debug_v22.3_win.exe | This executable file installs FlashPro Express that is used to program FPGA. |

3. Design Description

The following figure shows a high-level block diagram of the design.

Figure 3-1. Block Diagram

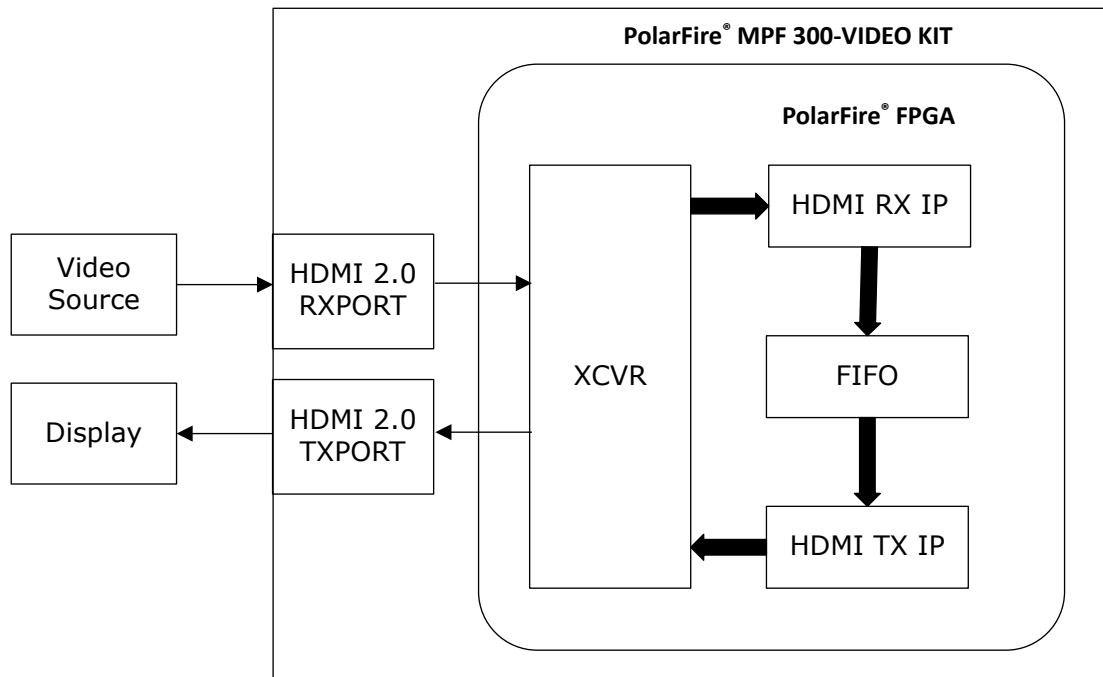

The video input is received through a HDMI compliant video source through the HDMI RX port. The serial HDMI data is converted to parallel data by XCVR. XCVR is configured for four lanes for HDMI video reception and transmission. The XCVR Lane 0 is a clock lane and remaining three lanes such as B, G, and R are used as data channels. XCVR is configured for 1.5 Gbps with 40 bits parallel data width to serialize four pixels per clock.

The 40 bits data (4 pixels) received at HDMI RX IP is decoded as either a video data or an auxiliary data, and the respective valid signals and frame control signals are generated. The decoded video data, audio data, and control signals are packed and written into a FIFO. The FIFO output data is unpacked to video, auxiliary, and control signals, which are given as inputs to the HDMI TX IP. The HDMI TX IP encodes the data using TMDS encoding. The encoded data is serialized by XCVR and sent to HDMI TX port. The display connected to the HDMI TX port receives the encoded data from the HDMI TX IP, which is the same video and audio as the HDMI RX input.

3.1 Hardware Implementation

The following figure shows the Libero SoC implementation of the top-level SmartDesign.

Figure 3-2. High-Level HDMI Loopback Design

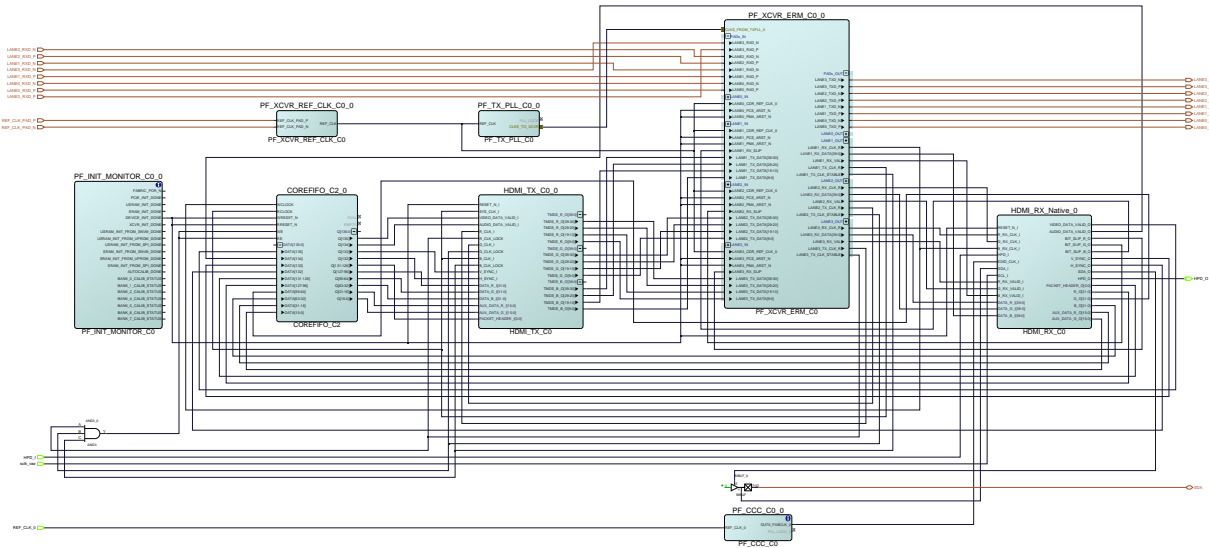

The high-level HDMI loopback design includes the following key IP cores:

- XCVR
- HDMI TX IP
- HDMI RX IP
- FIFO
- XCVR

XCVR is configured in Full-Duplex mode, as the system receives Transition Minimized Differential Signaling (TMDS) data and transmits the encoded TMDS. XCVR uses LANE 0 for clock data and LANE 1, LANE 2, and LANE 3 a data lanes, and HDMI has three data channels such as: B, G, and R. In this system, the XCVR data rate is selected to support Full High Definition (FHD) video data transmission and reception at 60 FPS. XCVR serializes or deserializes the HDMI 40 bits data that contains four pixels where MSB 10 bits represent the latest pixel.

Figure 3-3. XCVR Configuration

| | | | |
|--|-------------------------|---|--------------|
| General | | | |
| Transceiver mode | Tx and Rx (Full Duplex) | <input type="checkbox"/> Enhanced receiver management | |
| Number of lanes | 4 | Receiver calibration | None (CDR) |
| | | <input type="checkbox"/> Incrementally recalibrate data eye | |
| | | <input type="checkbox"/> Incrementally recalibrate DFE coefficients | |
| PMA Settings | | | |
| TX data rate | 1485 Mbps | RX data rate | 1485 Mbps |
| TX clock division factor | 4 | RX CDR lock mode | Lock to data |
| TX PLL base data rate | 5940.000 Mbps | RX CDR reference clock source | Dedicated |
| TX PLL bit clock frequency | 2970.000 MHz | RX CDR reference clock frequency | 148.5 MHz |
| | | RX JA clock frequency | 37.125 MHz |
| PCS Settings | | | |
| TX PCS-Fabric interface width | 40 bits | RX PCS-Fabric interface width | 40 bits |
| TX FPGA interface frequency | 37.125 MHz | RX FPGA interface frequency | 37.125 MHz |
| PMA Mode | | | |
| <input checked="" type="checkbox"/> Enable CDR Bit-slip port | | | |
| <input type="checkbox"/> 8b10b Encoding/Decoding | | | |
| <input type="checkbox"/> 64b66b Gear Box | | | |
| <input checked="" type="radio"/> 64b66b | | <input checked="" type="radio"/> 64b67b | |
| <input type="checkbox"/> Enable Disparity | | <input type="checkbox"/> Enable BER monitor state machine | |
| <input type="checkbox"/> Enable Scrambler/Descrambler | | <input type="checkbox"/> Enable 32 bits data width | |
| SoR PIPE Interface | | | |
| Protocol: PCIe Gen1 (2.5 Gbps) | | | |
| Clocks and Resets | | | |
| Interface Clocks | | | |
| <input type="checkbox"/> Use as PLL reference clock | | | |
| TX clock | Regional | RX clock | Regional |

The HDMI RX IP is configured with four pixels per clock for native interface.

Figure 3-4. HDMI RX IP Configuration

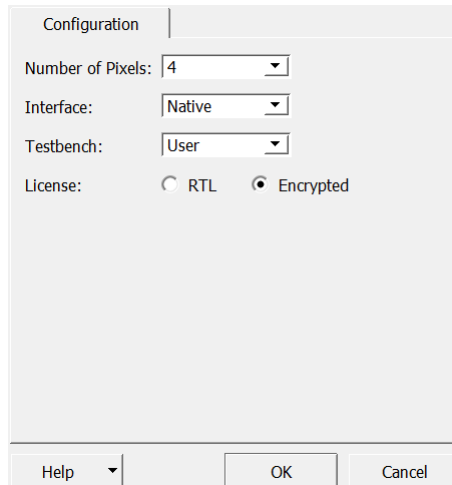

The screenshot shows a configuration dialog box titled "Configuration". It contains the following settings:

- Number of Pixels: 4 (dropdown menu)
- Interface: Native (dropdown menu)
- Testbench: User (dropdown menu)
- License: RTL Encrypted

At the bottom of the dialog, there are three buttons: "Help" (with a dropdown arrow), "OK", and "Cancel".

The HDMI RX IP decodes the TMDS data to video, auxiliary data, and control signals. The HDMI RX IP can be configured to operate in one pixel per clock or four with the interface type as Native and AXI-4.

The FIFO core passes the decoded data of video and audio and control signals to HDMI TX IP for encoding. The HDMI TX IP is configured in **Audio Mode** as **Enable** to encode the audio data along with the video data.

Figure 3-5. HDMI TX IP Configuration

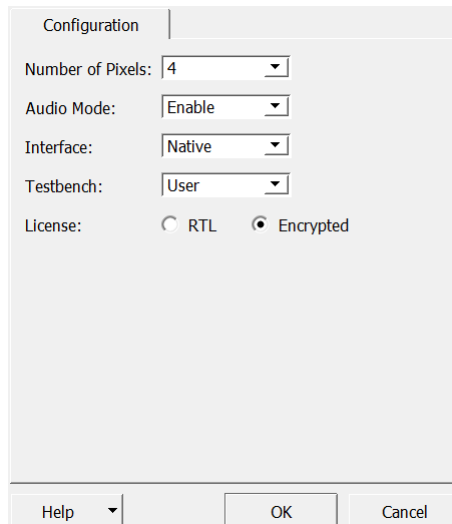

The screenshot shows a configuration dialog box titled "Configuration". It contains the following settings:

- Number of Pixels: 4 (dropdown menu)
- Audio Mode: Enable (dropdown menu)
- Interface: Native (dropdown menu)
- Testbench: User (dropdown menu)
- License: RTL Encrypted

At the bottom of the dialog, there are three buttons: "Help" (with a dropdown arrow), "OK", and "Cancel".

3.2 I/O Ports

The following table lists the important I/O ports of the design.

Table 3-1. Important I/O Ports

| I/O Port | Direction | Description |
|---------------|------------------|------------------------|
| LANE0_RXD_N | Input | Lane 0 RX channel N |
| LANE0_RXD_P | Input | Lane 0 RX channel P |
| LANE1_RXD_N | Input | Lane 1 RX channel N |
| LANE1_RXD_P | Input | Lane 1 RX channel P |
| LANE2_RXD_N | Input | Lane 2 RX channel N |
| LANE2_RXD_P | Input | Lane 2 RX channel P |
| LANE3_RXD_N | Input | Lane 3 RX channel N |
| LANE3_RXD_P | Input | Lane 3 RX channel P |
| REF_CLK_PAD_N | Input | Reference clock N |
| REF_CLK_PAD_P | Input | Reference clock P |
| REF_CLK_0 | Input | Reference clock |
| SDA | Input and Output | Serial data |
| sclk_raw | Input | Serial clock |
| HPD_I | Input | Hot plug detect input |
| LANE0_TXD_N | Output | Lane 0 TX channel N |
| LANE0_TXD_P | Output | Lane 0 TX channel P |
| LANE1_TXD_N | Output | Lane 1 TX channel N |
| LANE1_TXD_P | Output | Lane 1 TX channel P |
| LANE2_TXD_N | Output | Lane 2 TX channel N |
| LANE2_TXD_P | Output | Lane 2 TX channel P |
| LANE3_TXD_N | Output | Lane 3 TX channel N |
| LANE3_TXD_P | Output | Lane 3 TX channel P |
| HPD_O | Output | Hot plug detect output |

3.3 Clocking Structure

The design uses the following on-board clocks:

- The 27 MHz oscillator is used to provide a reference clock to PF_CCC_C0 and generates Extended Display Identification Data (EDID) clock of 150 MHz; the 148.5 MHz clock is used as a reference clock to XCVR as shown in the following figure.
- The XCVR TX PLL subsystem generates a bit clock, and XCVR transmits and receives clocks. The on-board 50 MHz clock is used as an I²C serial clock.

The following figure shows the clocking structure of the design.

Figure 3-6. Clocking Structure

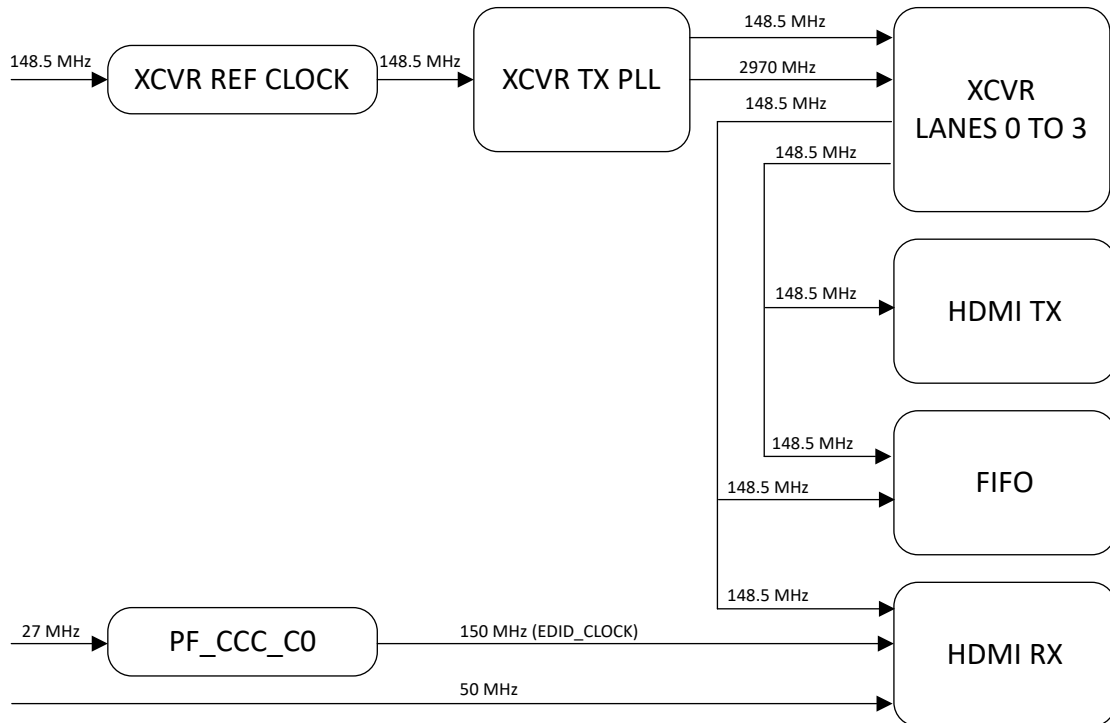

3.4 Reset Structure

The HDMI loopback design is released from the reset when the DEVICE_INIT_DONE signal of the PF_INIT_MONITIR block is de-asserted.

The following figure shows the reset structure of the design.

Figure 3-7. Reset Structure

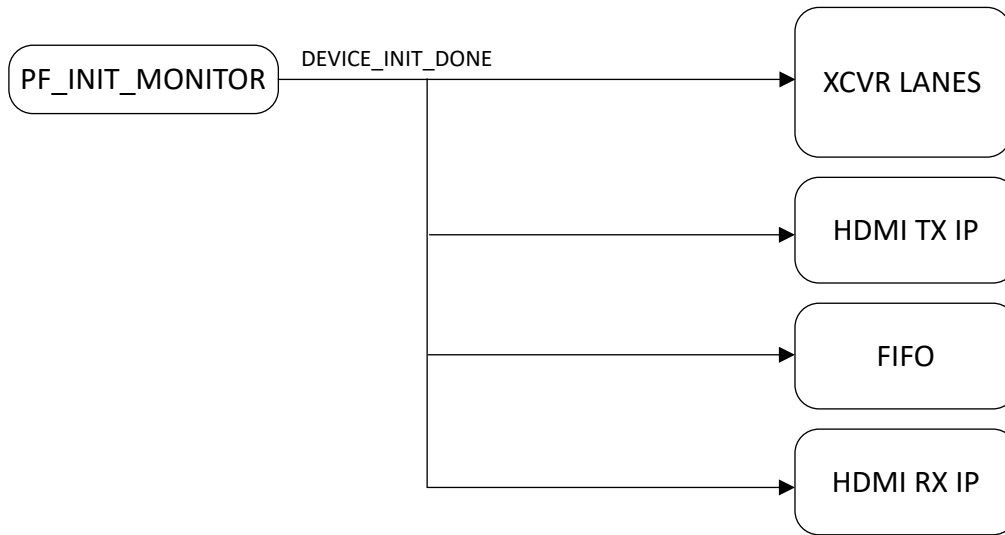

4. Setting Up the Demo

Setting up the demo involves the following steps:

1. [Setting Up the Hardware](#)
2. [Programming the Device](#)

4.1 Setting Up the Hardware

Setting up the hardware involves interfacing HDMI source (Host PC) and HDMI display with the PolarFire Video Kit and verifying the jumper settings.

Perform the following steps to set up the hardware:

1. Connect the Host PC and the video kit through **J12** of the video kit using the USB mini cable.
2. Connect the HDMI 1920x1080 display to **J1** (HDMI 2.0 TX port) of the video kit.
3. Connect the HDMI source to **J35** (HDMI 2.0 RX port) of the video kit.
4. Connect the Host PC and video kit through the USB port (J12) of the video kit using the USB mini cable.
5. Connect the power supply cable to **J20** of the video kit.
6. Power up the HDMI monitor.
7. Power up the board using the **SW4** slide switch.

4.2 Programming the Device

To program the PolarFire device with the `.job` file provided as part of the design files using the FlashPro Express software, see [6. Appendix A : Programming the Device using FlashPro Express](#).

5. Running the Demo

When programming is done, the video sent by the source is displayed on the sink (monitor).

This concludes the demo.

6. Appendix A : Programming the Device using FlashPro Express

This section describes how to program the PolarFire device with the .job file using FlashPro Express. The HDMI_RX_TX.job file is available at the following location.

```
<$designfiles download
directory>\mpf_an4768_v2022p2_df\VKPFHDMIRXTX\designer\HDMI_RX_TX\export
```

Perform the following steps to program the PolarFire device with the .job file:

1. On the Host PC, start the FlashPro Express software from its installation directory.
2. Select **New** or **New Job Project from FlashPro Express Job** from Project menu to create a new job project.
3. Enter the following in the **New Job Project from FlashPro Express Job** dialog box:
 - a. Programming job file: Click **Browse** and navigate to the location where the HDMI_RX_TX.job file is located and select the file. The default location is <\$ designfiles download directory>\mpf_an4768_v2022p2_df\VKPFHDMIRXTX\designer\HDMI_RX_TX\export.
 - b. FlashPro Express job project location: Select **Browse** and navigate to the location where you want to save the project.
4. Click **OK**. The required programming file is selected and ready to be programmed in the device. The FlashPro Express window appears.
5. Verify that a programmer number appears in the **Programmer** box. If it does not, verify the board connections and click **Refresh/Rescan Programmers**.
6. Click **Run** to program the device. When the device is programmed successfully, a **Run PASSED** status is displayed.
7. Close FlashPro Express (**Project > Exit**). The PolarFire device and SPI Flash are programmed.
8. Power cycle the board using the **SW4** switch. After power cycling, the full HD displays the video from the Host PC.

7. Revision History

The revision history describes the changes that were implemented in the document. The changes are listed by revision, starting with the current publication.

Table 7-1. Revision History

| Revision | Date | Description |
|----------|---------|-------------------|
| A | 11/2022 | Initial revision. |

Microchip FPGA Support

Microchip FPGA products group backs its products with various support services, including Customer Service, Customer Technical Support Center, a website, and worldwide sales offices. Customers are suggested to visit Microchip online resources prior to contacting support as it is very likely that their queries have been already answered.

Contact Technical Support Center through the website at www.microchip.com/support. Mention the FPGA Device Part number, select appropriate case category, and upload design files while creating a technical support case.

Contact Customer Service for non-technical product support, such as product pricing, product upgrades, update information, order status, and authorization.

- From North America, call **800.262.1060**
- From the rest of the world, call **650.318.4460**
- Fax, from anywhere in the world, **650.318.8044**

Microchip Information

The Microchip Website

Microchip provides online support via our website at www.microchip.com/. This website is used to make files and information easily available to customers. Some of the content available includes:

- **Product Support** – Data sheets and errata, application notes and sample programs, design resources, user's guides and hardware support documents, latest software releases and archived software
- **General Technical Support** – Frequently Asked Questions (FAQs), technical support requests, online discussion groups, Microchip design partner program member listing
- **Business of Microchip** – Product selector and ordering guides, latest Microchip press releases, listing of seminars and events, listings of Microchip sales offices, distributors and factory representatives

Product Change Notification Service

Microchip's product change notification service helps keep customers current on Microchip products. Subscribers will receive email notification whenever there are changes, updates, revisions or errata related to a specified product family or development tool of interest.

To register, go to www.microchip.com/pcn and follow the registration instructions.

Customer Support

Users of Microchip products can receive assistance through several channels:

- Distributor or Representative
- Local Sales Office
- Embedded Solutions Engineer (ESE)
- Technical Support

Customers should contact their distributor, representative or ESE for support. Local sales offices are also available to help customers. A listing of sales offices and locations is included in this document.

Technical support is available through the website at: www.microchip.com/support

Microchip Devices Code Protection Feature

Note the following details of the code protection feature on Microchip products:

- Microchip products meet the specifications contained in their particular Microchip Data Sheet.
- Microchip believes that its family of products is secure when used in the intended manner, within operating specifications, and under normal conditions.
- Microchip values and aggressively protects its intellectual property rights. Attempts to breach the code protection features of Microchip product is strictly prohibited and may violate the Digital Millennium Copyright Act.
- Neither Microchip nor any other semiconductor manufacturer can guarantee the security of its code. Code protection does not mean that we are guaranteeing the product is “unbreakable”. Code protection is constantly evolving. Microchip is committed to continuously improving the code protection features of our products.

Legal Notice

This publication and the information herein may be used only with Microchip products, including to design, test, and integrate Microchip products with your application. Use of this information in any other manner violates these terms. Information regarding device applications is provided only for your convenience and may be superseded by updates. It is your responsibility to ensure that your application meets with your specifications. Contact your local Microchip sales office for additional support or, obtain additional support at www.microchip.com/en-us/support/design-help/client-support-services.

THIS INFORMATION IS PROVIDED BY MICROCHIP "AS IS". MICROCHIP MAKES NO REPRESENTATIONS OR WARRANTIES OF ANY KIND WHETHER EXPRESS OR IMPLIED, WRITTEN OR ORAL, STATUTORY OR OTHERWISE, RELATED TO THE INFORMATION INCLUDING BUT NOT LIMITED TO ANY IMPLIED WARRANTIES OF NON-INFRINGEMENT, MERCHANTABILITY, AND FITNESS FOR A PARTICULAR PURPOSE, OR WARRANTIES RELATED TO ITS CONDITION, QUALITY, OR PERFORMANCE.

IN NO EVENT WILL MICROCHIP BE LIABLE FOR ANY INDIRECT, SPECIAL, PUNITIVE, INCIDENTAL, OR CONSEQUENTIAL LOSS, DAMAGE, COST, OR EXPENSE OF ANY KIND WHATSOEVER RELATED TO THE INFORMATION OR ITS USE, HOWEVER CAUSED, EVEN IF MICROCHIP HAS BEEN ADVISED OF THE POSSIBILITY OR THE DAMAGES ARE FORESEEABLE. TO THE FULLEST EXTENT ALLOWED BY LAW, MICROCHIP'S TOTAL LIABILITY ON ALL CLAIMS IN ANY WAY RELATED TO THE INFORMATION OR ITS USE WILL NOT EXCEED THE AMOUNT OF FEES, IF ANY, THAT YOU HAVE PAID DIRECTLY TO MICROCHIP FOR THE INFORMATION.

Use of Microchip devices in life support and/or safety applications is entirely at the buyer's risk, and the buyer agrees to defend, indemnify and hold harmless Microchip from any and all damages, claims, suits, or expenses resulting from such use. No licenses are conveyed, implicitly or otherwise, under any Microchip intellectual property rights unless otherwise stated.

Trademarks

The Microchip name and logo, the Microchip logo, Adaptec, AVR, AVR logo, AVR Freaks, BesTime, BitCloud, CryptoMemory, CryptoRF, dsPIC, flexPWR, HELDO, IGLOO, JukeBlox, KeeLoq, Kleer, LANCheck, LinkMD, maXStylus, maXTouch, MediaLB, megaAVR, Microsemi, Microsemi logo, MOST, MOST logo, MPLAB, OptoLyzer, PIC, picoPower, PICSTART, PIC32 logo, PolarFire, Prochip Designer, QTouch, SAM-BA, SenGenuity, SpyNIC, SST, SST Logo, SuperFlash, Symmetricom, SyncServer, Tachyon, TimeSource, tinyAVR, UNI/O, Vectron, and XMEGA are registered trademarks of Microchip Technology Incorporated in the U.S.A. and other countries.

AgileSwitch, APT, ClockWorks, The Embedded Control Solutions Company, EtherSynch, Flashtec, Hyper Speed Control, HyperLight Load, Libero, motorBench, mTouch, Powermite 3, Precision Edge, ProASIC, ProASIC Plus, ProASIC Plus logo, Quiet- Wire, SmartFusion, SyncWorld, Temux, TimeCesium, TimeHub, TimePictra, TimeProvider, TrueTime, and ZL are registered trademarks of Microchip Technology Incorporated in the U.S.A.

Adjacent Key Suppression, AKS, Analog-for-the-Digital Age, Any Capacitor, AnyIn, AnyOut, Augmented Switching, BlueSky, BodyCom, Clockstudio, CodeGuard, CryptoAuthentication, CryptoAutomotive, CryptoCompanion, CryptoController, dsPICDEM, dsPICDEM.net, Dynamic Average Matching, DAM, ECAN, Espresso T1S, EtherGREEN, GridTime, IdealBridge, In-Circuit Serial Programming, ICSP, INICnet, Intelligent Paralleling, IntelliMOS, Inter-Chip Connectivity, JitterBlocker, Knob-on-Display, KoD, maxCrypto, maxView, memBrain, Mindi, MiWi, MPASM, MPF, MPLAB Certified logo, MPLIB, MPLINK, MultiTRAK, NetDetach, Omniscient Code Generation, PICDEM, PICDEM.net, PICkit, PICTail, PowerSmart, PureSilicon, QMatrix, REAL ICE, Ripple Blocker, RTAX, RTG4, SAM-

ICE, Serial Quad I/O, simpleMAP, SimpliPHY, SmartBuffer, SmartHLS, SMART-I.S., storClad, SQI, SuperSwitcher, SuperSwitcher II, Switchtec, SynchroPHY, Total Endurance, Trusted Time, TSHARC, USBCheck, VariSense, VectorBlox, VeriPHY, ViewSpan, WiperLock, XpressConnect, and ZENA are trademarks of Microchip Technology Incorporated in the U.S.A. and other countries.

SQTP is a service mark of Microchip Technology Incorporated in the U.S.A.

The Adaptec logo, Frequency on Demand, Silicon Storage Technology, and Symmcom are registered trademarks of Microchip Technology Inc. in other countries.

GestIC is a registered trademark of Microchip Technology Germany II GmbH & Co. KG, a subsidiary of Microchip Technology Inc., in other countries.

All other trademarks mentioned herein are property of their respective companies.

© 2022, Microchip Technology Incorporated and its subsidiaries. All Rights Reserved.

ISBN: 978-1-6683-1501-9

Quality Management System

For information regarding Microchip's Quality Management Systems, please visit www.microchip.com/quality.

Worldwide Sales and Service

| AMERICAS | ASIA/PACIFIC | ASIA/PACIFIC | EUROPE |
|---|---|--|---|
| <p>Corporate Office 2355 West Chandler Blvd. Chandler, AZ 85224-6199 Tel: 480-792-7200 Tel: 480-792-7277 Technical Support: www.microchip.com/support Web Address: www.microchip.com</p> <p>Atlanta Duluth, GA Tel: 678-957-9614 Fax: 678-957-1455</p> <p>Austin, TX Tel: 512-257-3370</p> <p>Boston Westborough, MA Tel: 774-760-0087 Fax: 774-760-0088</p> <p>Chicago Itasca, IL Tel: 630-285-0071 Fax: 630-285-0075</p> <p>Dallas Addison, TX Tel: 972-818-7423 Fax: 972-818-2924</p> <p>Detroit Novi, MI Tel: 248-848-4000</p> <p>Houston, TX Tel: 281-894-5983</p> <p>Indianapolis Noblesville, IN Tel: 317-773-8323 Fax: 317-773-5453 Tel: 317-536-2380</p> <p>Los Angeles Mission Viejo, CA Tel: 949-462-9523 Fax: 949-462-9608 Tel: 951-273-7800</p> <p>Raleigh, NC Tel: 919-844-7510</p> <p>New York, NY Tel: 631-435-6000</p> <p>San Jose, CA Tel: 408-735-9110 Tel: 408-436-4270</p> <p>Canada - Toronto Tel: 905-695-1980 Fax: 905-695-2078</p> | <p>Australia - Sydney Tel: 61-2-9868-6733</p> <p>China - Beijing Tel: 86-10-8569-7000</p> <p>China - Chengdu Tel: 86-28-8665-5511</p> <p>China - Chongqing Tel: 86-23-8980-9588</p> <p>China - Dongguan Tel: 86-769-8702-9880</p> <p>China - Guangzhou Tel: 86-20-8755-8029</p> <p>China - Hangzhou Tel: 86-571-8792-8115</p> <p>China - Hong Kong SAR Tel: 852-2943-5100</p> <p>China - Nanjing Tel: 86-25-8473-2460</p> <p>China - Qingdao Tel: 86-532-8502-7355</p> <p>China - Shanghai Tel: 86-21-3326-8000</p> <p>China - Shenyang Tel: 86-24-2334-2829</p> <p>China - Shenzhen Tel: 86-755-8864-2200</p> <p>China - Suzhou Tel: 86-186-6233-1526</p> <p>China - Wuhan Tel: 86-27-5980-5300</p> <p>China - Xian Tel: 86-29-8833-7252</p> <p>China - Xiamen Tel: 86-592-2388138</p> <p>China - Zhuhai Tel: 86-756-3210040</p> | <p>India - Bangalore Tel: 91-80-3090-4444</p> <p>India - New Delhi Tel: 91-11-4160-8631</p> <p>India - Pune Tel: 91-20-4121-0141</p> <p>Japan - Osaka Tel: 81-6-6152-7160</p> <p>Japan - Tokyo Tel: 81-3-6880-3770</p> <p>Korea - Daegu Tel: 82-53-744-4301</p> <p>Korea - Seoul Tel: 82-2-554-7200</p> <p>Malaysia - Kuala Lumpur Tel: 60-3-7651-7906</p> <p>Malaysia - Penang Tel: 60-4-227-8870</p> <p>Philippines - Manila Tel: 63-2-634-9065</p> <p>Singapore Tel: 65-6334-8870</p> <p>Taiwan - Hsin Chu Tel: 886-3-577-8366</p> <p>Taiwan - Kaohsiung Tel: 886-7-213-7830</p> <p>Taiwan - Taipei Tel: 886-2-2508-8600</p> <p>Thailand - Bangkok Tel: 66-2-694-1351</p> <p>Vietnam - Ho Chi Minh Tel: 84-28-5448-2100</p> | <p>Austria - Wels Tel: 43-7242-2244-39 Fax: 43-7242-2244-393</p> <p>Denmark - Copenhagen Tel: 45-4485-5910 Fax: 45-4485-2829</p> <p>Finland - Espoo Tel: 358-9-4520-820</p> <p>France - Paris Tel: 33-1-69-53-63-20 Fax: 33-1-69-30-90-79</p> <p>Germany - Garching Tel: 49-8931-9700</p> <p>Germany - Haan Tel: 49-2129-3766400</p> <p>Germany - Heilbronn Tel: 49-7131-72400</p> <p>Germany - Karlsruhe Tel: 49-721-625370</p> <p>Germany - Munich Tel: 49-89-627-144-0 Fax: 49-89-627-144-44</p> <p>Germany - Rosenheim Tel: 49-8031-354-560</p> <p>Israel - Ra'anana Tel: 972-9-744-7705</p> <p>Italy - Milan Tel: 39-0331-742611 Fax: 39-0331-466781</p> <p>Italy - Padova Tel: 39-049-7625286</p> <p>Netherlands - Drunen Tel: 31-416-690399 Fax: 31-416-690340</p> <p>Norway - Trondheim Tel: 47-72884388</p> <p>Poland - Warsaw Tel: 48-22-3325737</p> <p>Romania - Bucharest Tel: 40-21-407-87-50</p> <p>Spain - Madrid Tel: 34-91-708-08-90 Fax: 34-91-708-08-91</p> <p>Sweden - Gothenberg Tel: 46-31-704-60-40</p> <p>Sweden - Stockholm Tel: 46-8-5090-4654</p> <p>UK - Wokingham Tel: 44-118-921-5800 Fax: 44-118-921-5820</p> |