

IGLOO2 FPGA DSP FIR Filter - Libero SoC v11.7

DG0504 Demo Guide



Contents

1	Preface	5
1.1	Purpose	5
1.2	Intended Audience	5
1.3	References	5
2	IGLOO2 FPGA DSP FIR Filter	6
2.1	Introduction	6
2.2	Design Requirements	7
2.3	Demo Design	7
2.3.1	Introduction	7
2.3.2	Demo Design Description	8
2.3.2.1	Data Handle	8
2.3.2.2	Filter Control	8
2.3.2.3	TPSRAM IP	9
2.3.2.4	CoreUART	9
2.3.2.5	CoreFIR	9
2.3.2.6	CoreFFT	9
2.3.2.7	SYSRESET	10
2.3.2.8	OSC	10
2.3.2.9	CCC	10
2.4	Setting Up the Demo Design	10
2.5	Programming the Demo Design	13
2.5.1	Setting Up the Device	14
2.5.2	Programming the Device	14
2.5.3	DSP FIR Demo GUI	16
2.6	Running the Demo Design	17
2.7	Conclusion	29
3	Appendix: SmartDesign Implementation	30
4	Appendix: Resource Usage Summary	31
5	Appendix: Coefficient Text File Format	32
6	Revision History	33
7	Product Support	34
7.1	Customer Service	34
7.2	Customer Technical Support Center	34
7.3	Technical Support	34
7.4	Website	34
7.5	Contacting the Customer Technical Support Center	34
7.5.1	Email	34
7.5.2	My Cases	34
7.5.3	Outside the U.S.	35
7.6	ITAR Technical Support	35

Figures

Figure 1.	Top-Level Diagram of DSP FIR Filter Demo	6
Figure 2.	Demo Design Files Top-Level Structure	7
Figure 3.	DSP FIR Filter Demo Design Block Diagram	8
Figure 4.	IGLOO2 Evaluation Kit DSP FIR Filter Demo Setup	11
Figure 5.	USB to UART Bridge Drivers	12
Figure 6.	FlashPro - New Project	13
Figure 7.	FlashPro Project Configuration	14
Figure 8.	FlashPro Project RUN Passed	15
Figure 9.	DSP FIR Demo Window	16
Figure 10.	Serial Port Configuration	17
Figure 11.	Filter Generation - 1	18
Figure 12.	Filter Generation - 2	19
Figure 13.	Filter Response and Filter Coefficient Plot	20
Figure 14.	Signal Generation	21
Figure 15.	Input Signal and Input Signal FFT Plot	22
Figure 16.	DSP FIR Filter Demo - Start	23
Figure 17.	Filtered Signal: Time and Frequency Plot	24
Figure 18.	Filtered Signal: GUI Options	25
Figure 19.	Text Viewer	26
Figure 20.	Text Viewer: Filter Coefficient Values	27
Figure 21.	Text Viewer: Coefficients Save Options	28
Figure 22.	FIR Filter Demo: Exit	29
Figure 23.	DSP FIR Filter SmartDesign	30
Figure 24.	Coefficient File Example – 9 Taps, Decimal Values	32

Tables

Table 1.	Design Requirements	7
Table 2.	TPSRAM Configuration for Data Buffers	9
Table 3.	IGLOO2 FPGA Evaluation Kit Jumper Settings	10
Table 4.	DSP FIR Filter Demo SmartDesign Blocks and Description	30
Table 5.	DSP FIR Filter Demo Resource Usage Summary	31
Table 6.	MACC Blocks Usage Summary	31
Table 7.	RAM1Kx18 Blocks Usage Summary	31

1 Preface

1.1 Purpose

This demo is for IGLOO[®]2 field programmable gate array (FPGA) devices. It provides instructions on how to use the corresponding reference design.

1.2 Intended Audience

This demo guide is intended for:

- FPGA designers
- System-level designers

1.3 References

The following documents are referred in this demo guide:

- *UG0451: IGLOO2 FPGA and SmartFusion2 SoC FPGA Programming User Guide*
- *UG0450: SmartFusion2 SoC FPGA and IGLOO2 FPGA System Controller User Guide*
- *UG0448: IGLOO2 FPGA High Performance Memory Subsystem User Guide*

Refer to the following web page for a complete and up-to-date listing of IGLOO2 device documentation: <http://www.microsemi.com/products/fpga-soc/fpga/igloo2docs>.

2 IGLOO2 FPGA DSP FIR Filter

2.1 Introduction

The IGLOO2 FPGA devices integrate a fourth generation flash-based FPGA fabric architecture, which includes embedded mathblocks optimized specifically for digital signal processing (DSP) applications such as, finite impulse response (FIR) filters, infinite impulse response (IIR) filters, and fast fourier transform (FFT) functions.

This demo shows a DSP FIR filter application using the IGLOO2 device. In this DSP FIR filter application, the host interface and the FIR filter are implemented in the fabric for low-pass, high-pass, band-pass, and band-reject filtering operations. A user-friendly graphical user interface (GUI) generates the filter coefficients, input signals (pass-band frequency and stop-band frequency), and also plots the input or output waveforms, and the required spectrum. Microsemi CoreFIR filter IP is used to suppress the unwanted frequency components, and CoreFFT IP is used to generate the output spectrum to verify the filtering operation.

Figure 1 shows the top-level diagram for the DSP FIR filter demo.

Figure 1 • Top-Level Diagram of DSP FIR Filter Demo

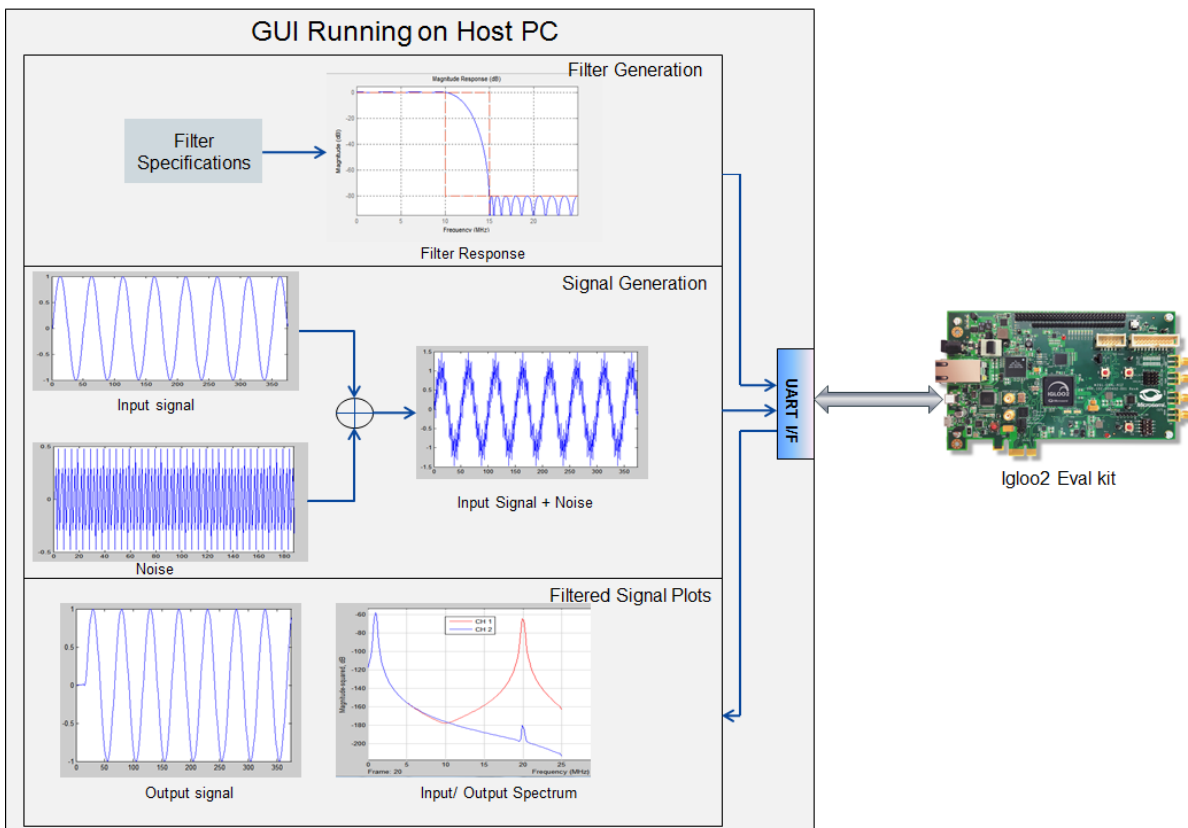

2.2 Design Requirements

Table 1 lists the hardware and software requirements.

Table 1 • Design Requirements

Design Requirements	Description
Hardware Requirements	
IGLOO2 Evaluation Kit: <ul style="list-style-type: none"> • FlashPro4 programmer • USB A to Mini-B cable 	Rev C or later
Host PC or Laptop	Windows 7 64-bit Operating System
Software Requirements	
Libero® system-on-chip (SoC)	v11.7
FlashPro Programming Software	v11.7
Host PC Drivers	USB to UART drivers
Framework	Microsoft .NET Framework 4 Client for launching demo GUI

2.3 Demo Design

2.3.1 Introduction

The design files are available for download from the following path in the Microsemi website:
http://soc.microsemi.com/download/rsc/?f=m2gl_dg0504_dsp_fir_filter_liberov11p7_df

The design files include:

- Design Files
- GUI
- Programming file
- Readme.txt file

Figure 2 shows the top-level structure of the design files. Refer to the Readme.txt file provided in the demo file folder for the complete directory structure.

Figure 2 • Demo Design Files Top-Level Structure

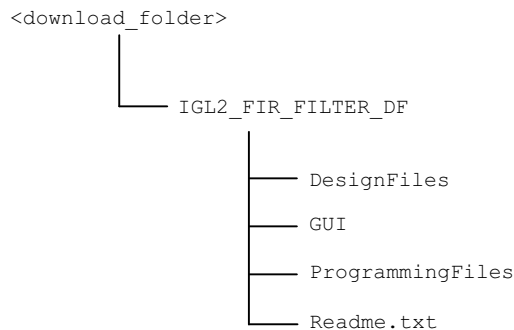

2.3.2 Demo Design Description

This demo design uses the following blocks:

- Data Handle (user RTL)
- Filter Control (user RTL)
- TPSRAM IP (IPcore)
- CoreUART (IPcore)
- CoreFIR (IPcore)
- CoreFFT (IPcore)
- SYSRESET (IPcore)
- OSC (IPcore)
- CCC (IPcore)

Figure 3 shows the detailed block diagram of the demo design.

Figure 3 • DSP FIR Filter Demo Design Block Diagram

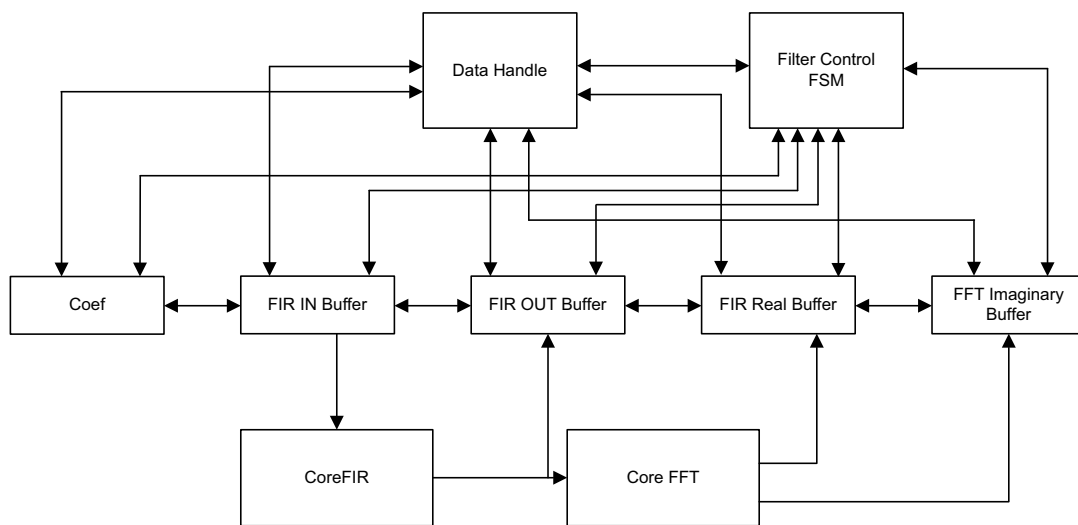

2.3.2.1 Data Handle

Data handle consists of the Core UART IP and the UART interface finite state machine handling the control operations between the host PC (GUI interface) and the fabric logic. Control operations include the loading of filter coefficients, filter input data to the corresponding input data buffer, coefficient buffers, and send and receive data from the Host PC GUI.

2.3.2.2 Filter Control

Controls the FIR filter and the FFT operations. It loads the filtered data to the corresponding output buffer and moves the FFT output data to the corresponding output data buffer.

2.3.2.3 TPSRAM IP

TPSRAM IP uses the following configurations:

- Filter coefficient buffer
- Input signal data buffer
- Output signal buffer
- Output signal FFT real data buffer
- Output signal FFT imaginary data buffer

Table 2 • TPSRAM Configuration for Data Buffers

Buffer	Write Port		Read Port	
	Depth	Width	Depth	Width
Filter Coefficients	64	8	32	16
FIR Input Signal	2048	8	1024	16
FIR Output Signal	1024	16	1024	16
FFT Output Real Signal	256	16	256	16
FFT Output Imaginary Signal	256	16	256	16

2.3.2.4 CoreUART

The Core UART IP is used to transfer the data between the host PC (GUI) and IGLOO2. The Core UART configuration is as follows:

- Version: 5.5.101
- TxFIFO: Disable TxFIFO
- RxFIFO: Disable RxFIFO
- RxLegacyMode: Disable
- Baud rate: 115200
- Number of bits: 8
- Stop bits: 1
- Parity: None

2.3.2.5 CoreFIR

The Core FIR IP is used in the Reloadable coefficient mode to support Low-pass, High-pass, Band-pass, and Band-reject filters. The Core FIR IP configuration is as follows:

- Version: 8.6.101
- Filter Type: Single rate fully enumerated
- Number of Taps: 31
- Coefficients Type: Reloadable
- Coefficients Bit Width: 16 (signed)
- Data Bit Width: 16 (signed)
- Filter Structure: Transposed with symmetry

2.3.2.6 CoreFFT

The Core FFT IP is used for generating the frequency spectrum of the filtered data. Core FFT IP configuration is as follows:

- Version: 6.4.105
- FFT Architecture: In place
- FFT Type: Forward
- FFT Scaling: Conditional
- FFT Transform Size: 256
- Width: 16

2.3.2.7 SYSRESET

The SYSRESET IP provides the power on reset signal.

2.3.2.8 OSC

The OSC IP is configured as an RC oscillator to provide the 50 MHz signal to the clock conditioning circuit (CCC).

2.3.2.9 CCC

The CCC IP is configured to provide a 150 MHz clock signal. For detailed smart design implementation and resource usage summary, refer to "Appendix: SmartDesign Implementation" on page 30.

2.4 Setting Up the Demo Design

The following steps describe how to setup the hardware demo:

1. Connect the jumpers on the IGLOO2 Evaluation Kit board, as shown in [Table 3](#).

Table 3 • IGLOO2 FPGA Evaluation Kit Jumper Settings

Jumper	Pin (From)	Pin (To)	Comments
J22	1	2	Default
J23	1	2	Default
J24	1	2	Default
J8	1	2	Default
J3	1	2	Default

CAUTION: While making the jumper connections, the power supply switch **SW7** must be switched OFF.

2. Connect the Power supply to the **J6** connector, switch ON the power supply switch, **SW7**.
3. Connect the FlashPro4 programmer to the **J5** connector of the IGLOO2 Evaluation Kit board.
4. Connect the host PC USB port to the **J18** USB connector on the IGLOO2 Evaluation Kit board using the USB Mini-B cable.

Figure 4 shows the board setup for running the DSP FIR Filter demo on the IGLOO2 Evaluation Kit.

Figure 4 • IGLOO2 Evaluation Kit DSP FIR Filter Demo Setup

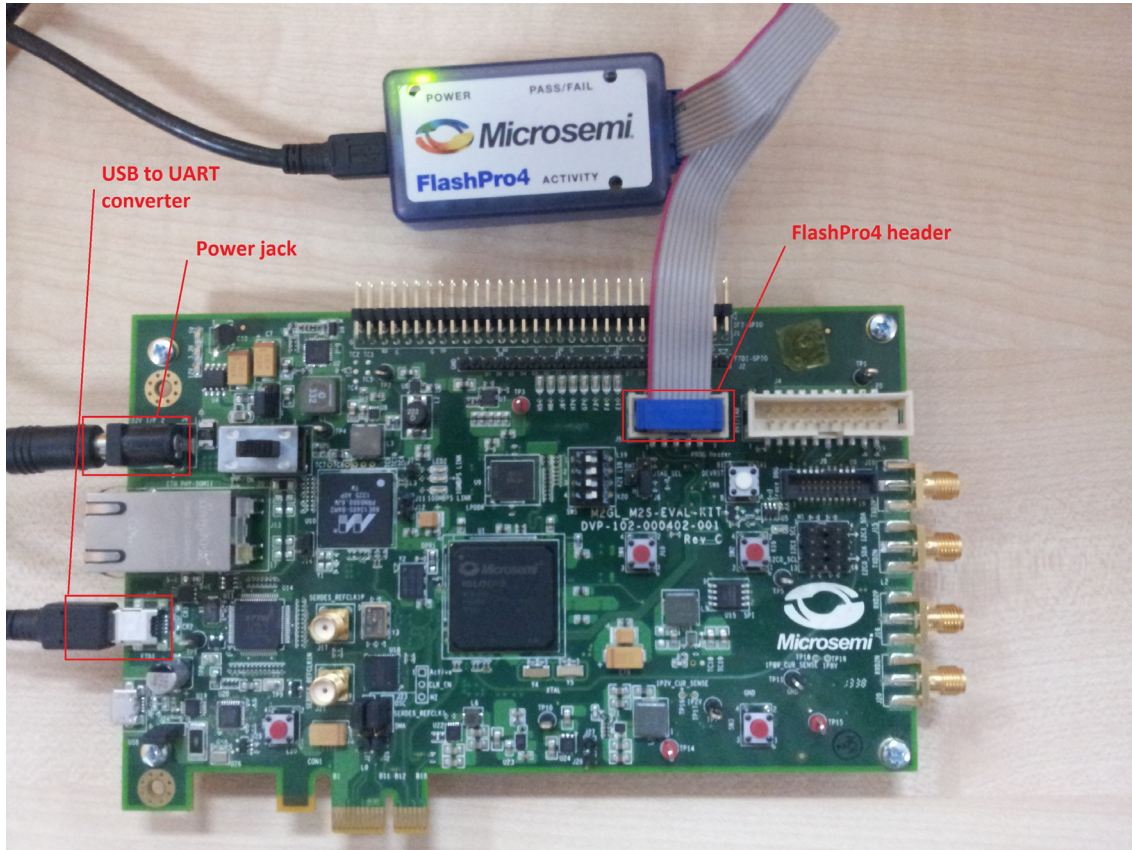

5. Ensure that the USB to UART bridge drivers are automatically detected. This can be verified in the **Device Manager** of the host PC. The FTDI USB to UART converter enumerates four COM ports. For USB 2.0, note down the USB Serial Converter D COM port number to use it in the `IGL2_FIR_Filter.exe`. [Figure 5](#) shows the USB 2.0 Serial port properties and the connected COM10 and USB Serial Converter D.

Figure 5 • USB to UART Bridge Drivers

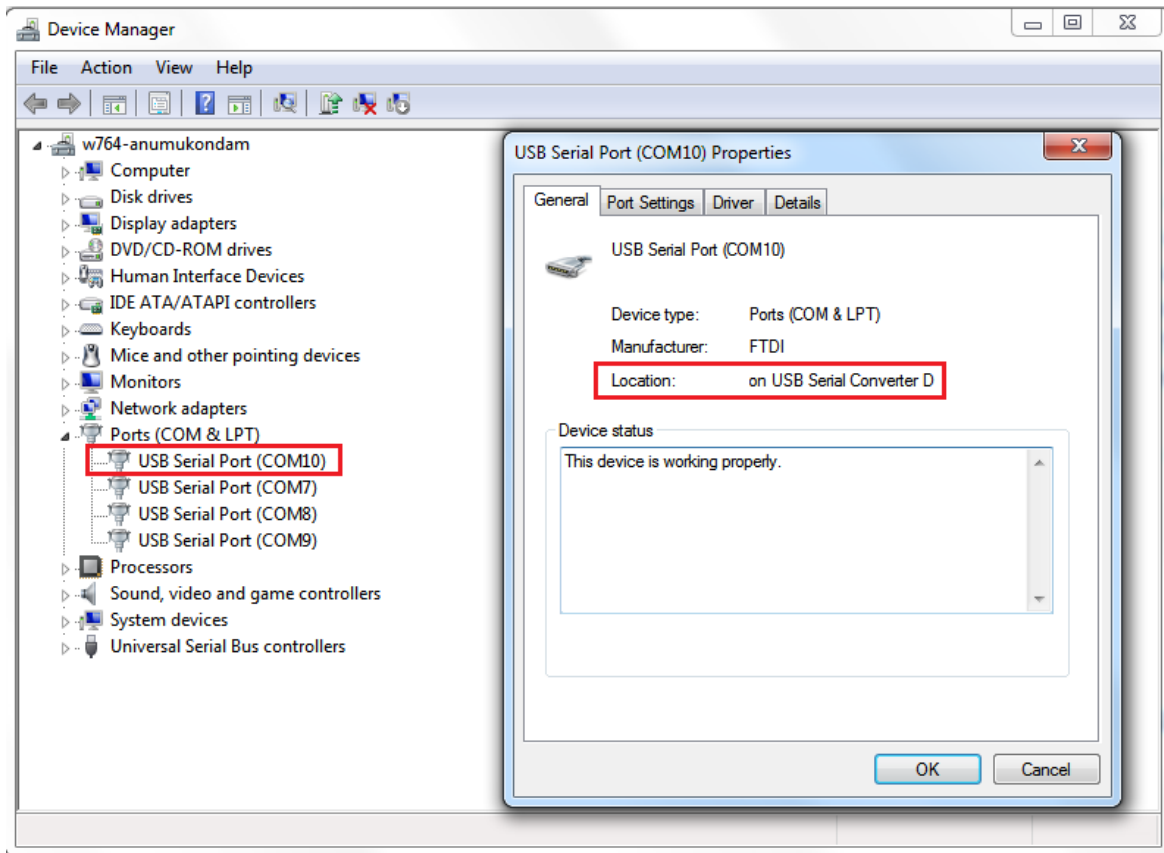

6. If the USB to UART bridge drivers are not installed, download and install the drivers from www.microsemi.com/documents/CDM_2.08.24_WHQL_Certified.zip.

2.5 Programming the Demo Design

The following steps describe how to program the demo design:

1. Download the demo design from:
http://soc.microsemi.com/download/rsc/?f=m2gl_dg0504_dsp_fir_filter_liberov11p7_df
2. Switch ON the power supply switch, SW7.
3. Launch the **FlashPro** software.
4. Click **New Project**.
5. In the **New Project** window, enter the project name as IGL2_FIR_FILTER.

Figure 6 • FlashPro - New Project

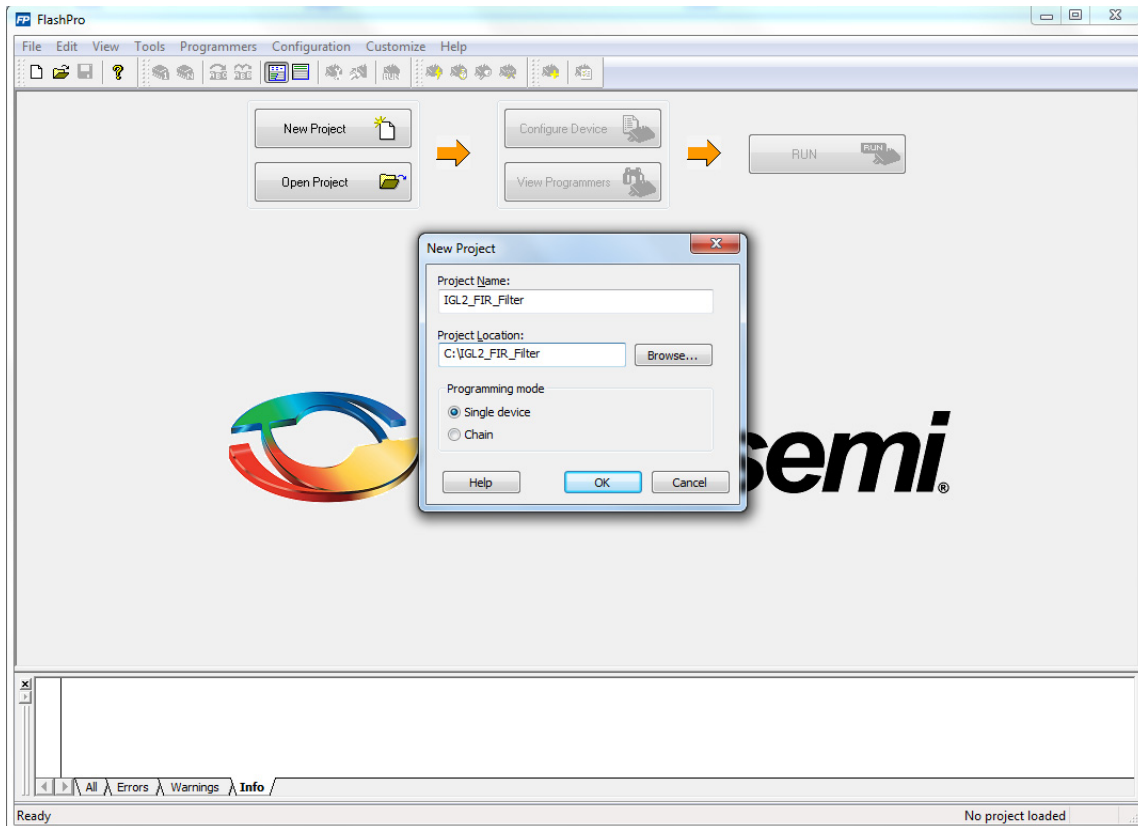

6. Click **Browse** and navigate to the location where you want to save the project.
7. Select **Single device** as the **Programming mode**.
8. Click **OK** to save the project.

2.5.1 Setting Up the Device

The following steps describe how to configure the device:

1. Click **Configure Device** on the FlashPro GUI.
2. Click **Browse** and navigate to the location where the IGL2_FIR_FILTER.stp file is located and select the file. The default location of the programming file is:
 <download_folder>\IGL2_FIR_FILTER_DF\ProgrammingFiles\IGL2_FIR_FILTER.stp.
3. Click **Open**. The required programming file is selected and is ready to be programmed in the device.
4. Select **Advanced** as Mode and **PROGRAM** as Action.

2.5.2 Programming the Device

Figure 7 • FlashPro Project Configuration

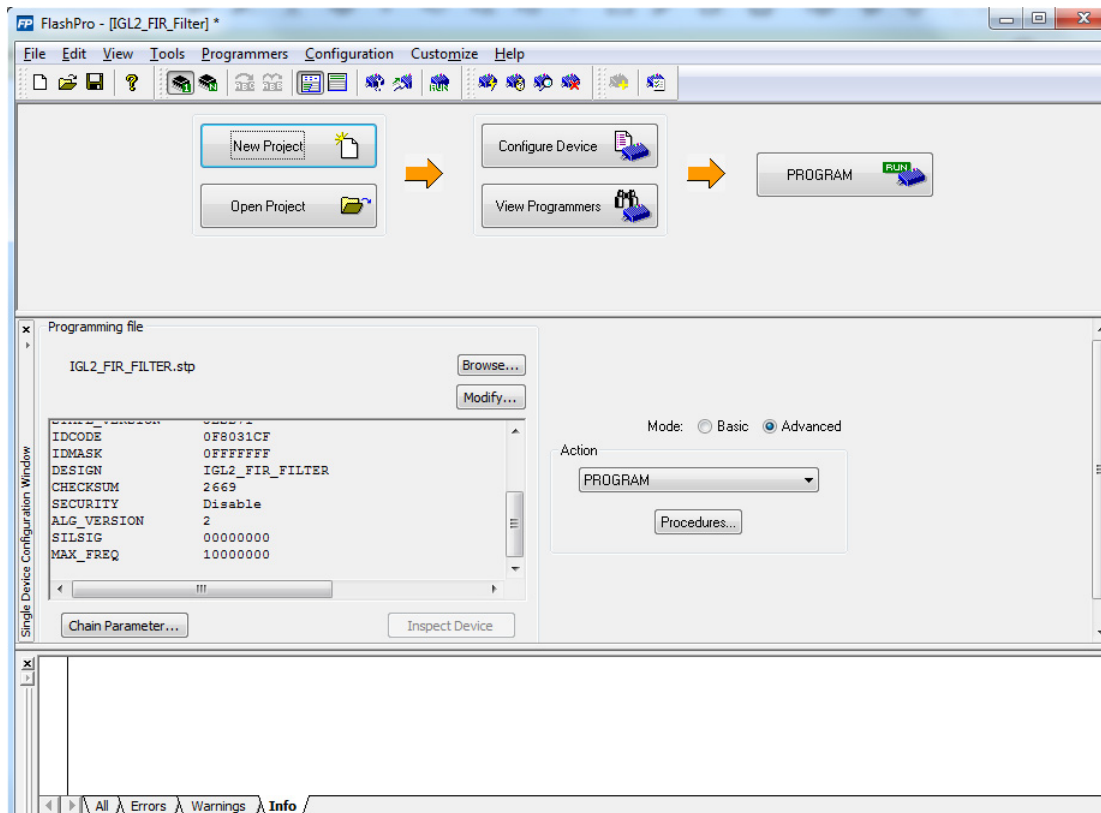

- Click **PROGRAM** to start programming the device. Wait until **Programmer Status** is changed to **RUN PASSED**.

Figure 8 • FlashPro Project RUN Passed

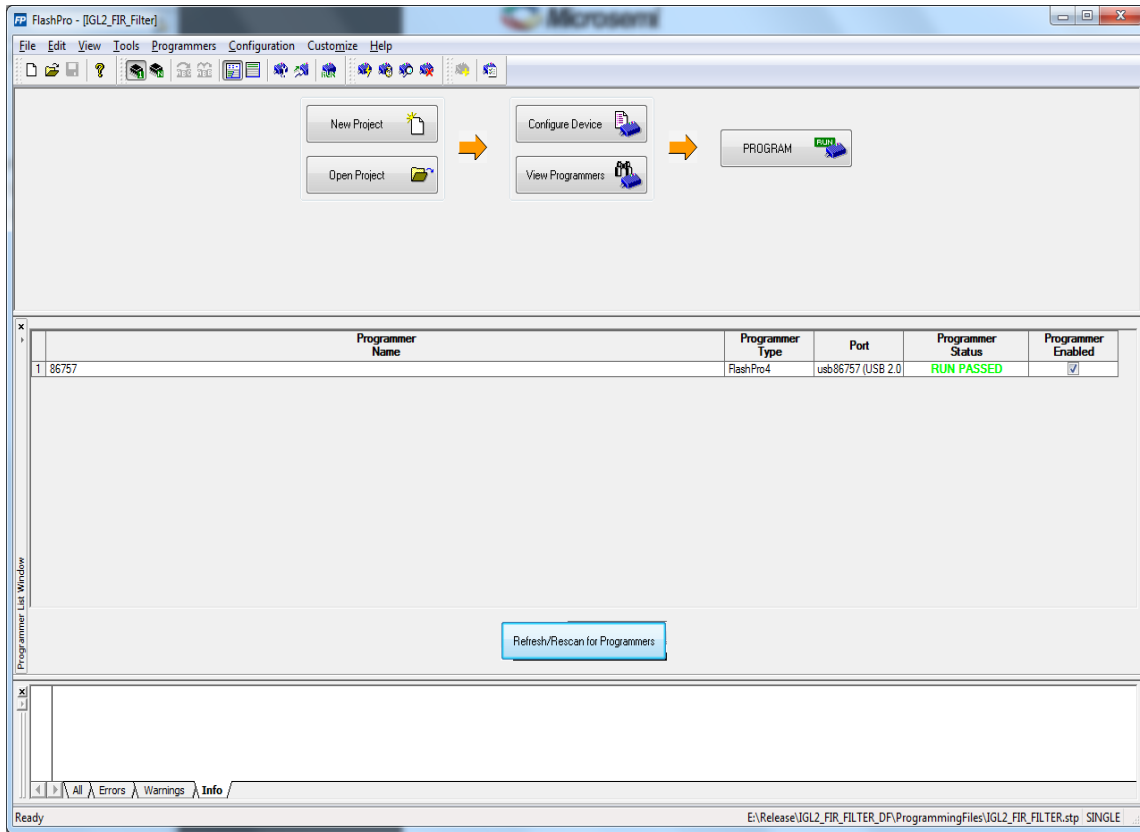

2.5.3 DSP FIR Demo GUI

The DSP FIR demo is provided with a user-friendly GUI that runs on the host PC which communicates with the IGLOO2 Evaluation Kit. The UART is used as the underlying communication protocol between the host PC and IGLOO2 Evaluation Kit.

Figure 9 shows the DSP FIR demo GUI.

Figure 9 • DSP FIR Demo Window

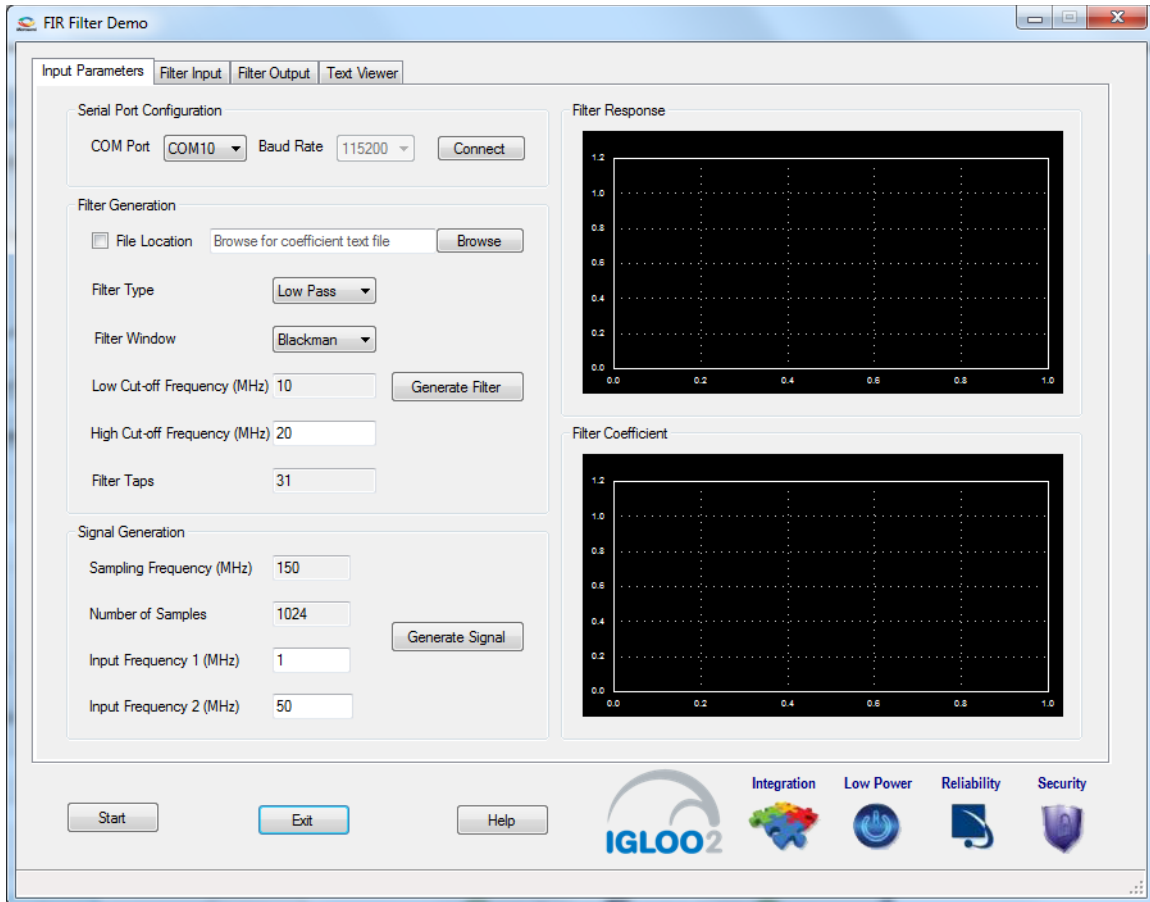

The DSP FIR demo window consists of the following tabs:

- **Input Parameters:** Configures the serial COM port, filter generation, and signal generation.
- **Filter Input:** Plots the input signal and its frequency spectrum
- **Filter Output:** Plots the output signal and its frequency spectrum
- **Text Viewer:** Shows the coefficients, input signal, output signal, and FFT data values

Click **Help** for more information on the GUI.

2.6 Running the Demo Design

The following steps describe how to run the demo design:

1. Launch the DSP FIR Demo GUI executable file available in the design files. (*IGL2_FIR_FILTER_DF\GUN\IGL2_FIR_Filter.exe*). The FIR Filter Demo window is displayed, as shown in Figure 10.

Figure 10 • Serial Port Configuration

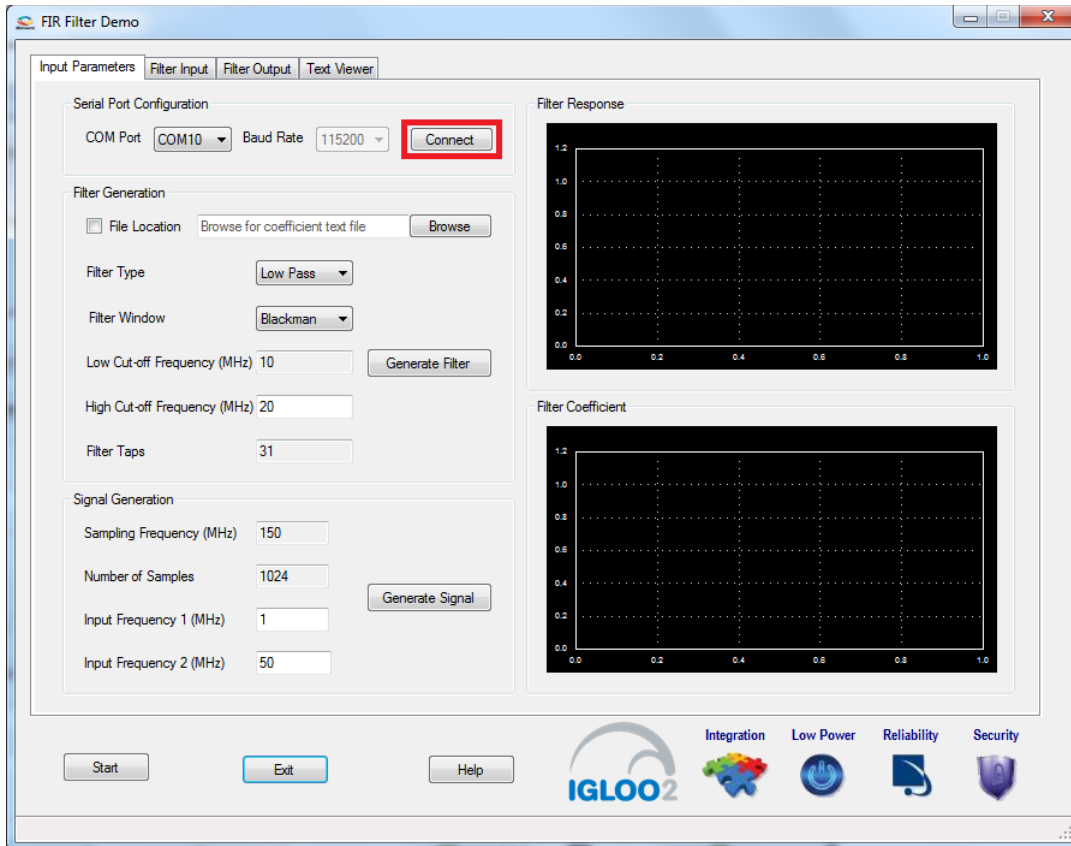

2. **Serial Port Configuration:** The COM port number is automatically detected and the baud rate is fixed at 115200. Click **Connect**. Refer to Figure 10.

3. **Filter Generation:** Two options are provided for generating the filter coefficients:
 - Generate the coefficients using MATLAB or any similar tool and save it as a text file (Refer to "Appendix: Coefficient Text File Format" on page 32 for the format of the text file). The GUI can be used to browse and load this file. Refer to Figure 11.

Figure 11 • Filter Generation - 1

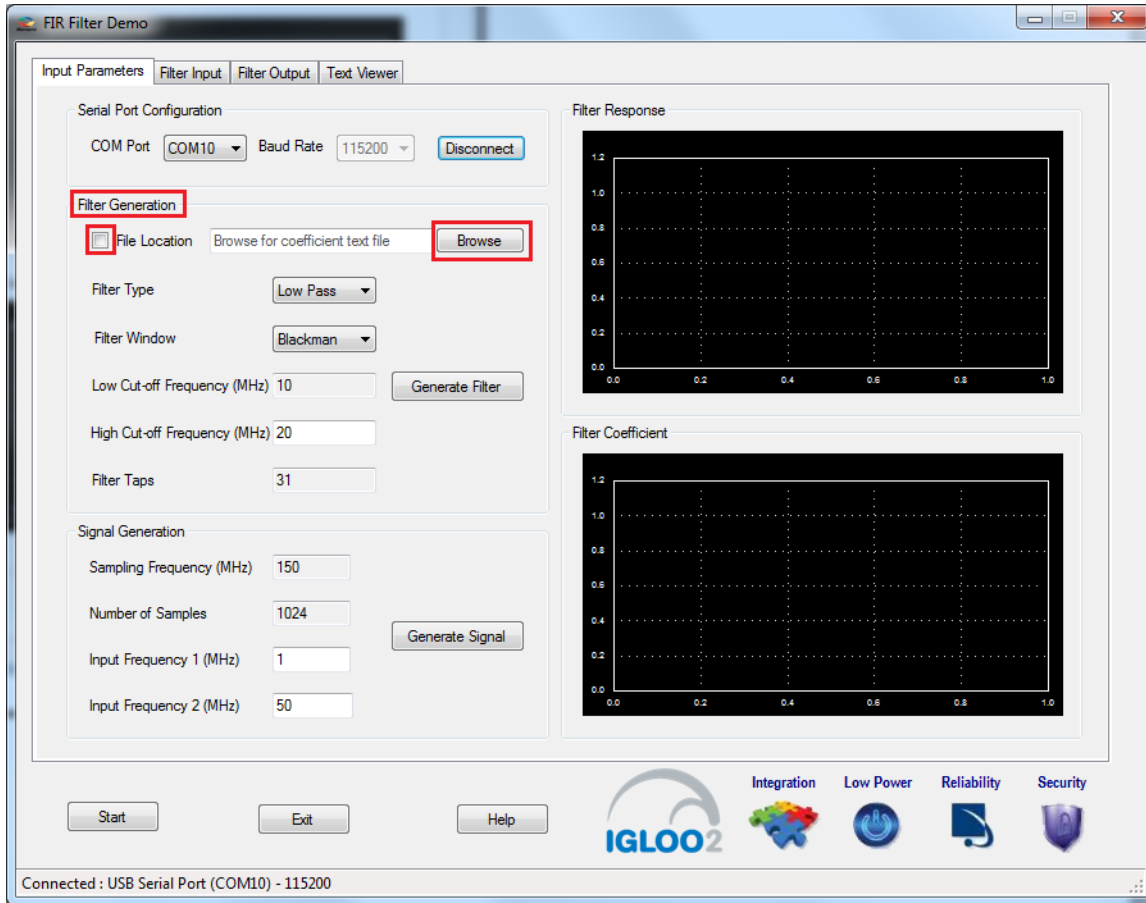

- Generate the Filter coefficients using the GUI.
The following parameters are required to generate filter coefficients:
 - **Filter Type:** Low-pass (Low-pass/High-pass/Band-pass/Band-reject filter)
 - **Filter Window:** Blackman (Blackman/Hamming window)
 - **Low Cut-off Frequency:** Disabled for Low-pass filter required (high cut-off frequency is disabled for high-pass filter)
 - **High Cut-off Frequency:** 20 MHz
 - **Filter Taps:** 31 (Fixed)
 Press **Generate Filter** to generate the filter coefficients.

Figure 12 • Filter Generation - 2

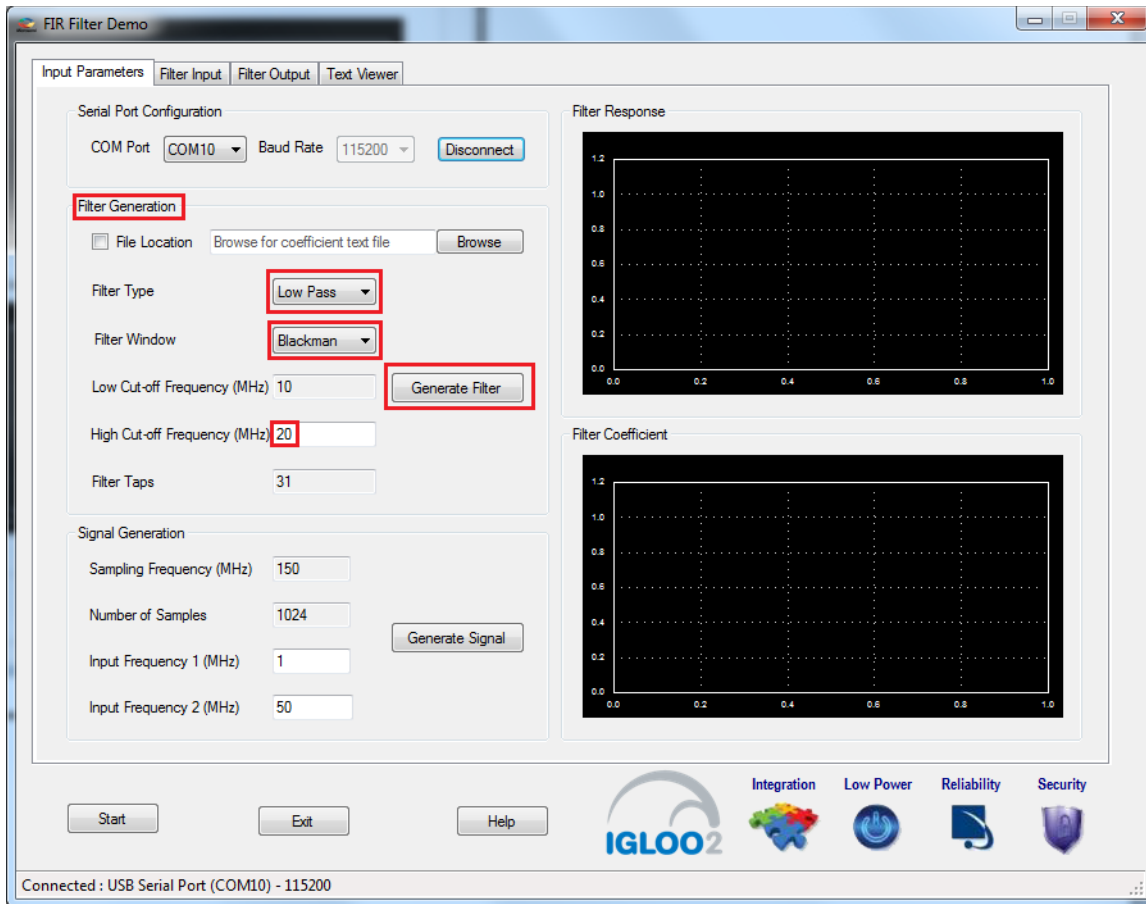

- The successful after-generation graphs of the filter coefficients, filter response, and the filter coefficient plots, are displayed. Refer to Figure 13.

Figure 13 • Filter Response and Filter Coefficient Plot

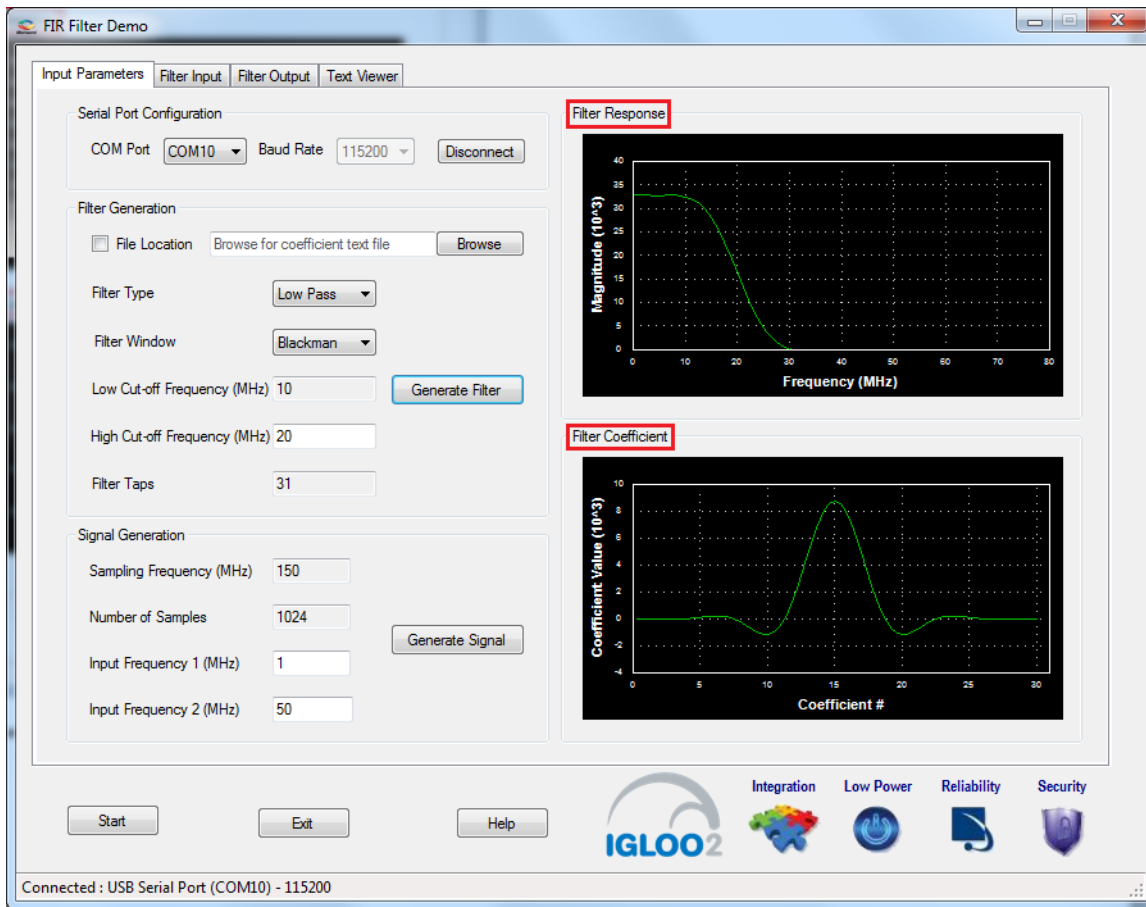

- The following parameters are required to generate **Signal Generation**:
 - **Sampling Frequency**: 150 MHz (Fixed)
 - **Number of Samples**: 1024 (Fixed)
 - **Input Frequency 1**: Enter the signal frequency in the Pass-band region. For example, 1 MHz to High cut-off frequency
 - **Input Frequency 2**: Enter the signal frequency in the Stop-band region. For example, High cut-off frequency to Sampling frequency/2
- 5. Click **Generate Signal**, as shown in Figure 14.

Figure 14 • Signal Generation

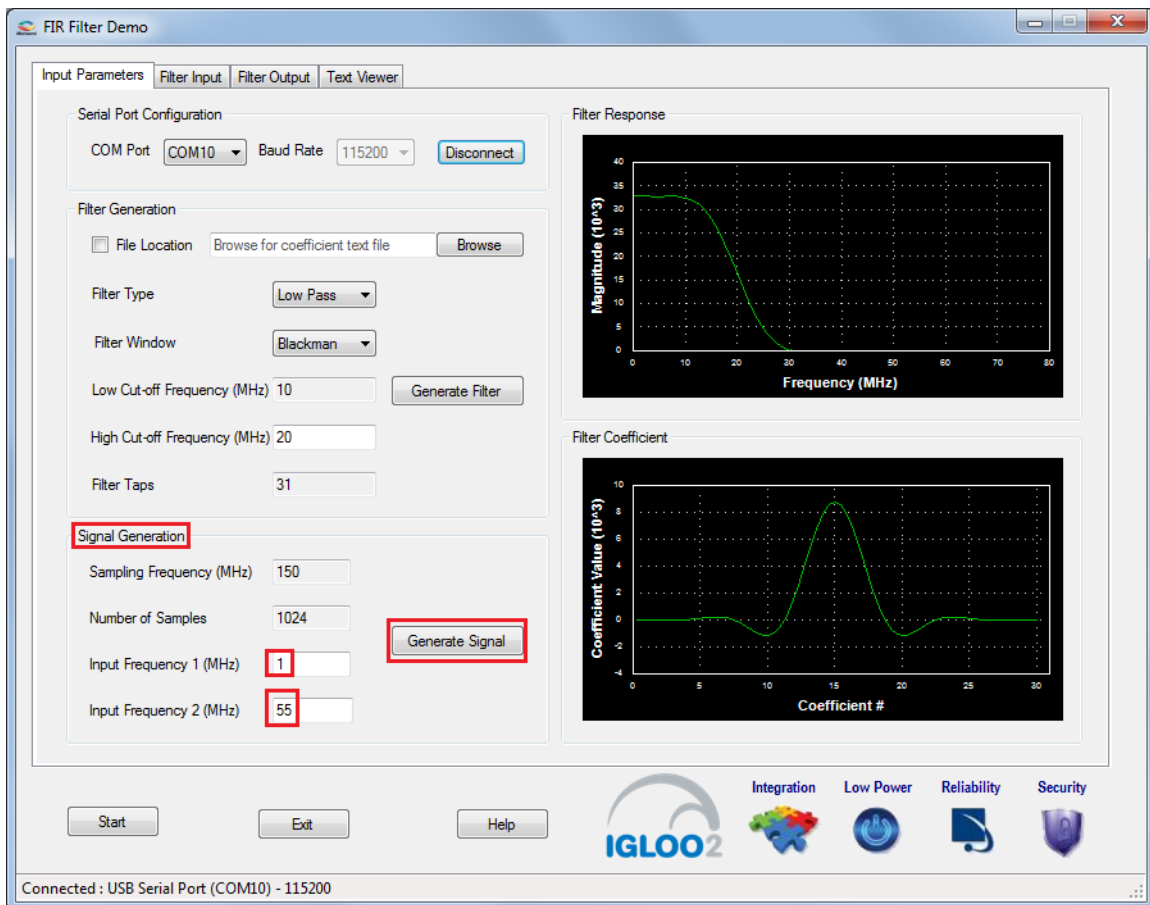

6. Input signal and frequency spectrum of the specified signal are displayed, as shown in Figure 15.

Figure 15 • Input Signal and Input Signal FFT Plot



- To configure the input frequencies and coefficients, click **Start**, as shown in Figure 16. It sends the input data (1K samples) and filter coefficients to the IGLOO2 device for processing the filtering operation.

Figure 16 • DSP FIR Filter Demo - Start



After completing the filter operation by the IGLOO2 device, the GUI plots the filtered data and the FFT data on the filter output window, as shown in Figure 17. Since Low-pass filter option was selected, the High frequency component is suppressed while the Low frequency signal is preserved. This can be observed in the frequency spectrum of the output signal.

Figure 17 • Filtered Signal: Time and Frequency Plot

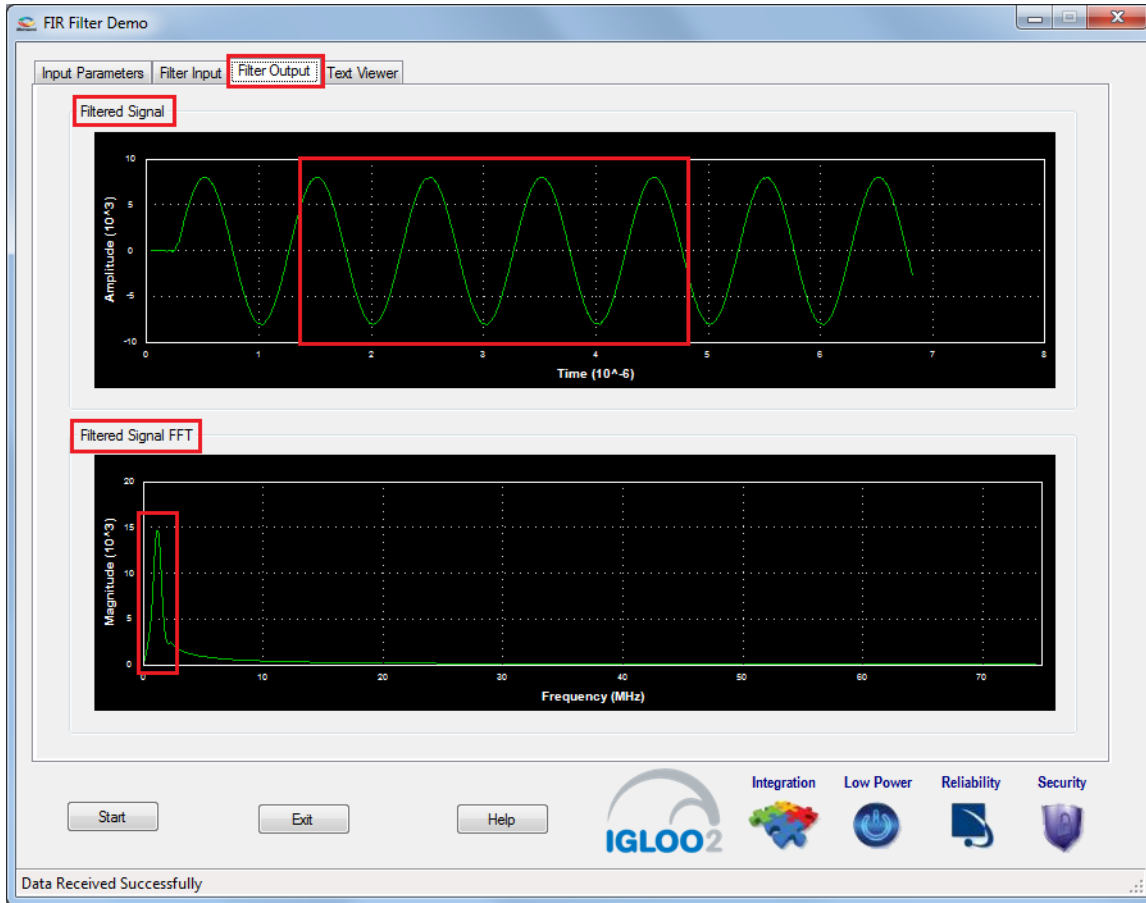

- Right-click on the window, it shows different options, as shown in Figure 18. The data can be copied, saved, and exported to the CSV plot for analysis purpose. Page setup, print, show point values, zoom, and set scale are set to default.

Figure 18 • Filtered Signal: GUI Options

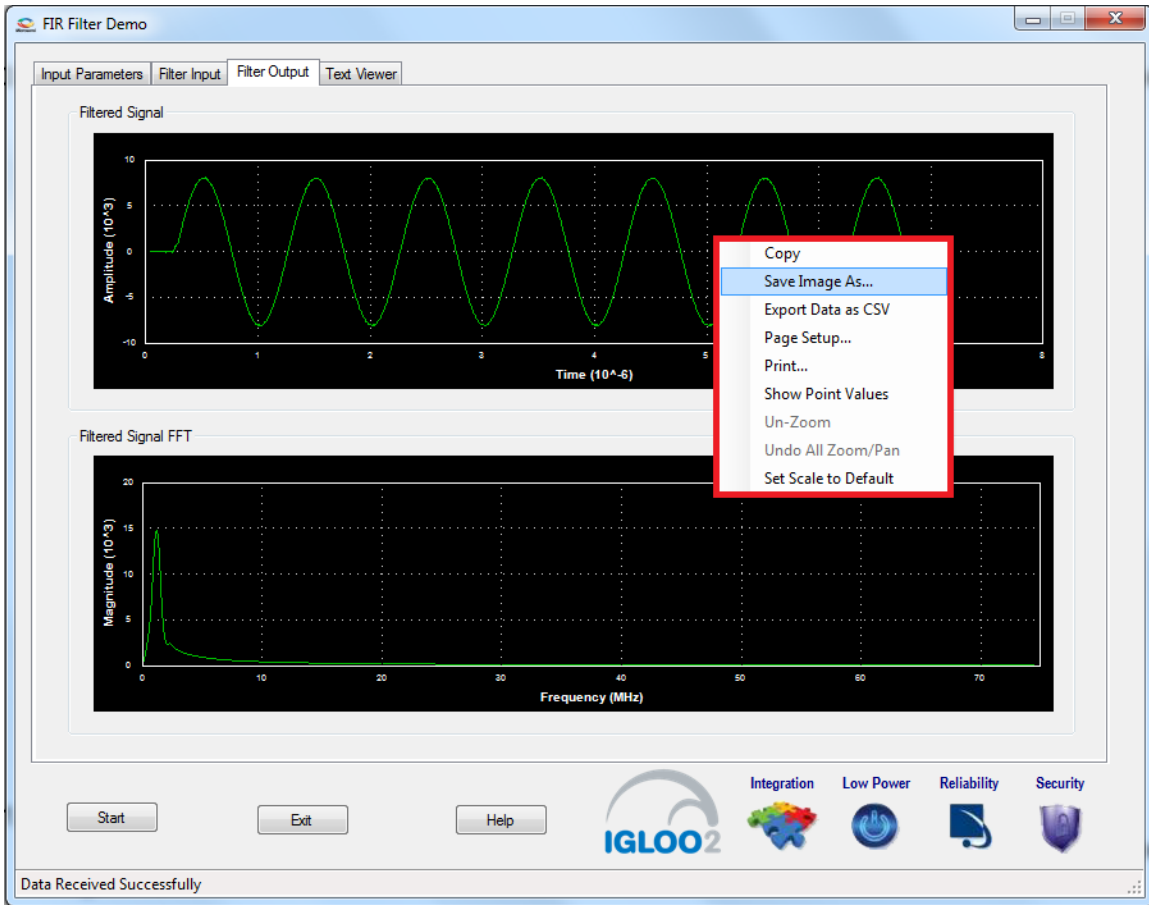

- The filter coefficients, input signal, output signal, and FFT output data values can be viewed in the **Text viewer**. Click **Text Viewer** and click the corresponding **View**, as shown in [Figure 19](#).

Figure 19 • Text Viewer

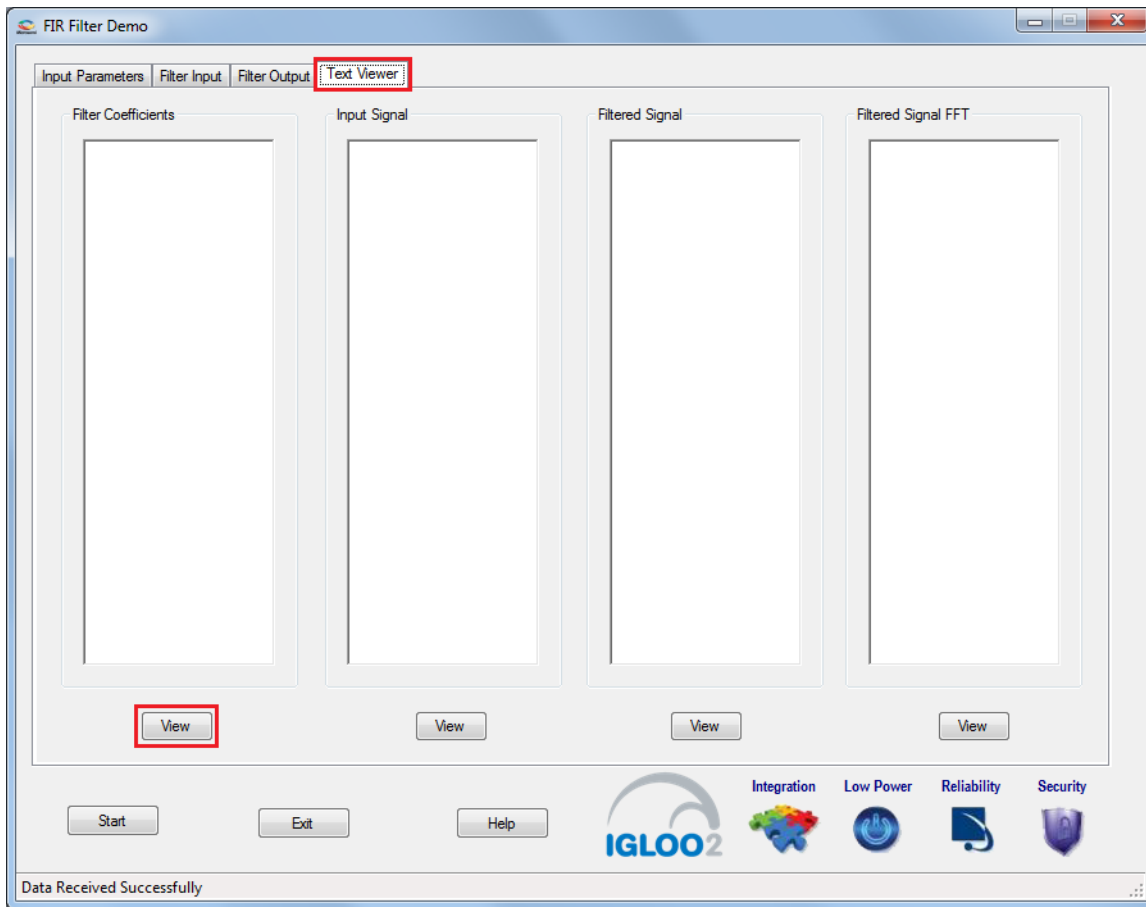

The values can be observed, as shown in Figure 20.

Figure 20 • Text Viewer: Filter Coefficient Values

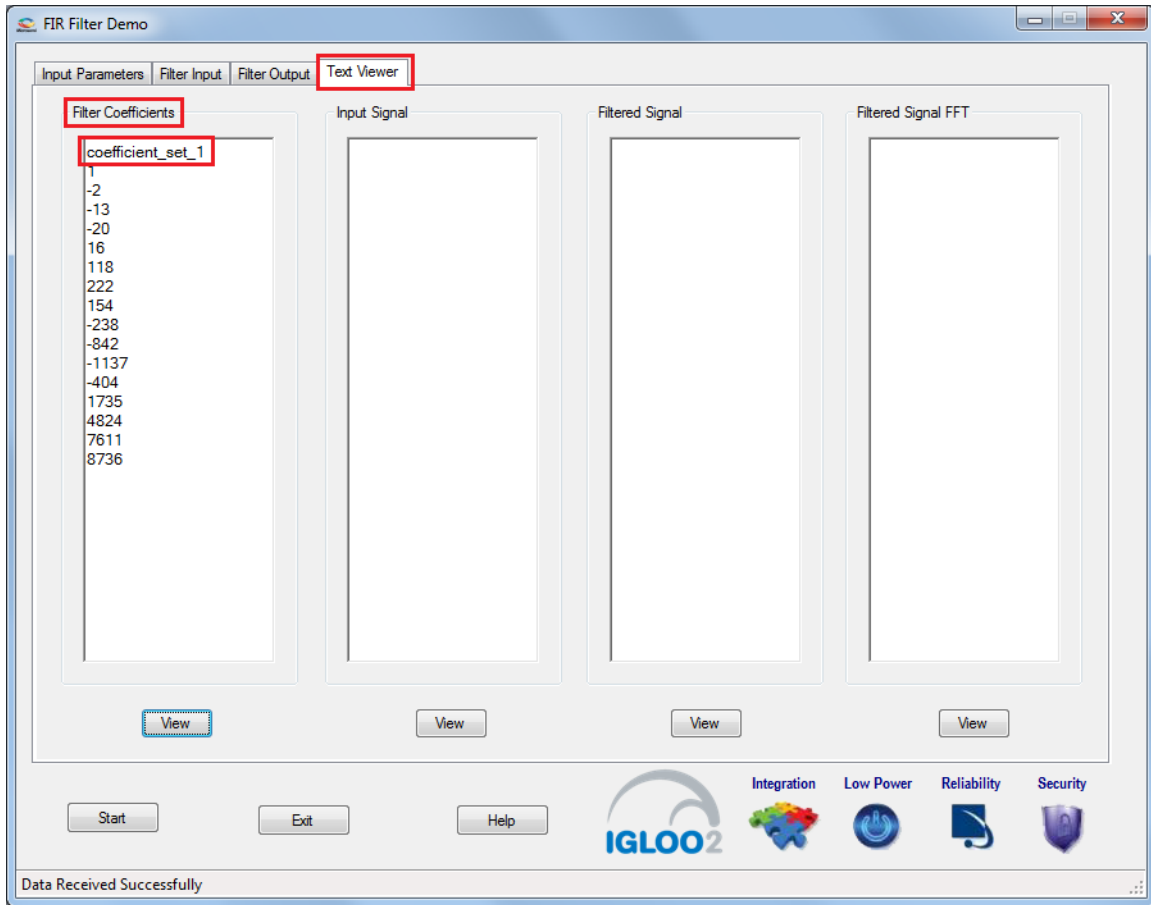

10. To save the coefficients as a text file, right-click **Filter Coefficients** window, it shows different options, as shown in [Figure 21](#). Click **Save** and select **OK** to save the text file.

Figure 21 • Text Viewer: Coefficients Save Options

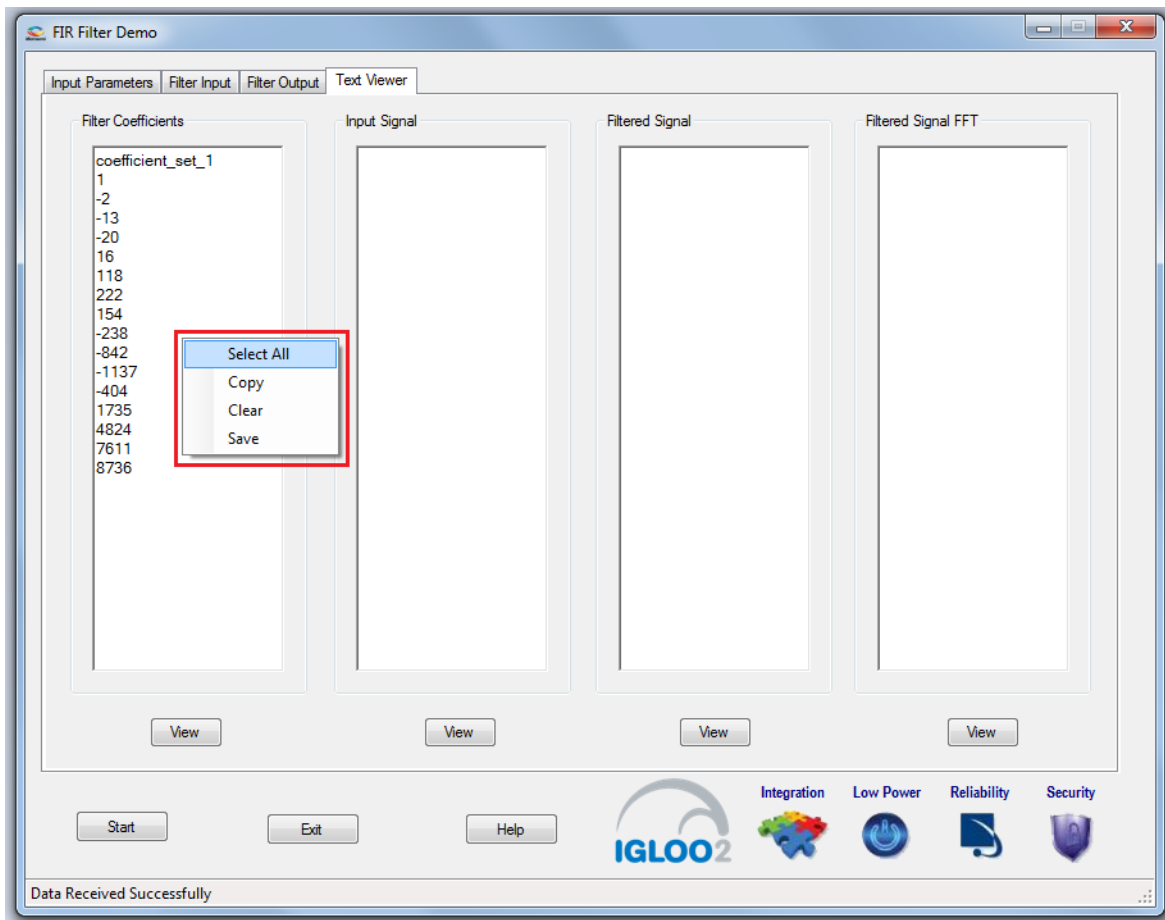

11. Click **Exit** to stop the demo, as shown in Figure 22.

Figure 22 • FIR Filter Demo: Exit

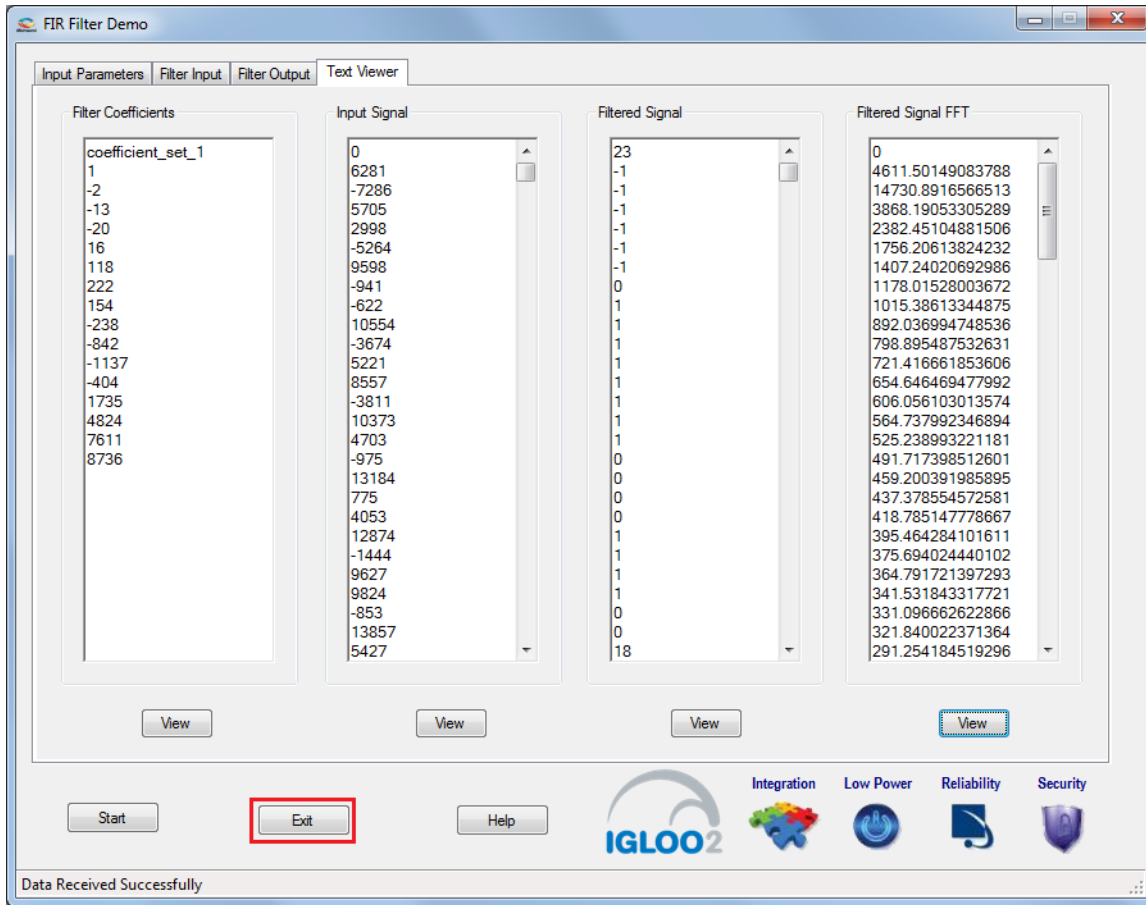

2.7 Conclusion

This demo shows the features of the IGLOO2 device including mathblocks and LSRAMS for DSP specific applications. Also provides information about how to use the Microsemi DSP IP cores (CoreFIR, and CoreFFT). This FIR Filter GUI-based demo is very easy to use and provides several options to understand and implement the DSP filters on the IGLOO2 device.

3 Appendix: SmartDesign Implementation

DSP FIR filter SmartDesign is shown in Figure 23.

Figure 23 • DSP FIR Filter SmartDesign

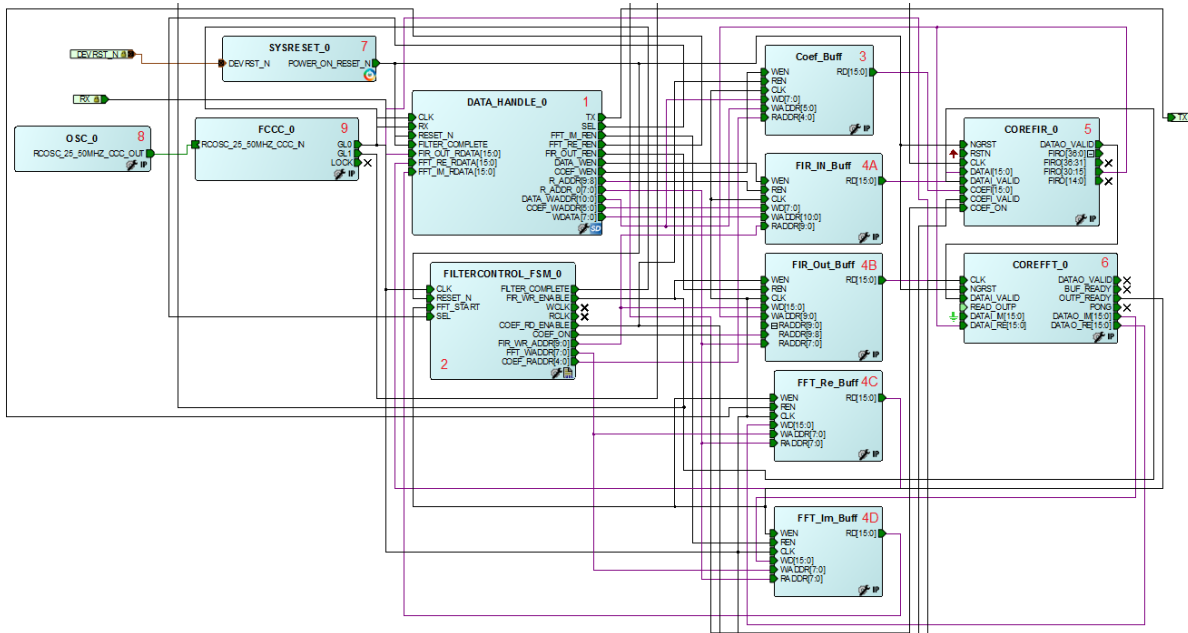

Table 4 shows SmartDesign blocks in DSP FIR Filter.

Table 4 • DSP FIR Filter Demo SmartDesign Blocks and Description

S.No	Block Name	Description
1	DATA_HANDLE_0	Handles the communication between the host PC and the IGLOO2 Evaluation Kit board.
2	FILTERCONTROL_FSM_0	Control logic to generate the control signals for the FIR and FFT operations.
3	Coef_Buff	IP for the filter coefficient buffer.
4	FIR_IN_Buff	IP for the FIR input signal data buffer.
	FIR_Out_Buff	IP for the FIR output signal buffer.
	FFT_Re_Buff	IP for the FFT output imaginary data buffer.
	FFT_Im_Buff	IP for the FFT output real data buffer.
5	COREFIR_0	COREFIR IP
6	COREFFT_0	COREFFT IP
7	SYSRESET_0	Reset IP
8	OSC_0	Oscillator IP
9	FCCC_0	Clock Conditioning circuit IP

4 Appendix: Resource Usage Summary

Table 5 shows DSP FIR filter resource usage summary.

Device: IGLOO2 device

Die: M2GL010

Package: 484 FBGA

Table 5 • DSP FIR Filter Demo Resource Usage Summary

Type	Used	Total	Percentage
4LUT	2867	12084	23.73
DFF	3747	12084	31.01
RAM64x18	0	22	0.00
RAM1Kx18	12	21	57.14
MACC	20	22	90.91

Table 6 shows MACC blocks usage summary.

Table 6 • MACC Blocks Usage Summary

CoreFIR	CoreFFT	Total
16	04	20

Table 7 shows RAM1Kx18 blocks usage summary.

Table 7 • RAM1Kx18 Blocks Usage Summary

CoreFIR	CoreFFT	Fabric Buffers	Total
0	7	5	12

5 Appendix: Coefficient Text File Format

The FIR filter coefficients can be loaded from an ASCII text file (*.txt). Create the coefficient file using a text editor. The format of the text file must be, as shown in [Figure 24](#). The coefficient values must be entered as integer numbers. For a symmetric or anti-symmetric filter, only half of the coefficients must be listed in the file (this applies to the fully enumerated type only). Only one coefficient value per line is permitted. An extra empty line must be placed after the last coefficient of the last set.

Figure 24 • Coefficient File Example – 9 Taps, Decimal Values

```
coefficient_set_1
5
6
10
25
63
- 1
- 11
- 32
- 63
```

6 Revision History

The following table shows important changes made in this document for each revision.

Revision	Changes
Revision 6 (April 2016)	Updated the document for Libero v11.7 software release (SAR 78044).
Revision 5 (October 2015)	Updated the document for Libero v11.6 software release (SAR 72354).
Revision 4 (January 2015)	Updated the document for Libero v11.5 software release (SAR 63927).
Revision 3 (August 2014)	Updated the document for Libero v11.4 software release (SAR 59681).
Revision 2 (June 2014)	Updated the document for Libero v11.3 software release (SAR 56265). Figure 3 on page 8 was updated.
Revision 1 (January 2014)	Initial release

7 Product Support

Microsemi SoC Products Group backs its products with various support services, including Customer Service, Customer Technical Support Center, a website, electronic mail, and worldwide sales offices. This appendix contains information about contacting Microsemi SoC Products Group and using these support services.

7.1 Customer Service

Contact Customer Service for non-technical product support, such as product pricing, product upgrades, update information, order status, and authorization.

From North America, call 800.262.1060
From the rest of the world, call 650.318.4460
Fax, from anywhere in the world, 408.643.6913

7.2 Customer Technical Support Center

Microsemi SoC Products Group staffs its Customer Technical Support Center with highly skilled engineers who can help answer your hardware, software, and design questions about Microsemi SoC Products. The Customer Technical Support Center spends a great deal of time creating application notes, answers to common design cycle questions, documentation of known issues, and various FAQs. So, before you contact us, please visit our online resources. It is very likely we have already answered your questions.

7.3 Technical Support

For Microsemi SoC Products Support, visit
<http://www.microsemi.com/products/fpga-soc/design-support/fpga-soc-support>.

7.4 Website

You can browse a variety of technical and non-technical information on the Microsemi SoC Products Group home page, at <http://www.microsemi.com/products/fpga-soc/fpga-and-soc>.

7.5 Contacting the Customer Technical Support Center

Highly skilled engineers staff the Technical Support Center. The Technical Support Center can be contacted by email or through the Microsemi SoC Products Group website.

7.5.1 Email

You can communicate your technical questions to our email address and receive answers back by email, fax, or phone. Also, if you have design problems, you can email your design files to receive assistance. We constantly monitor the email account throughout the day. When sending your request to us, please be sure to include your full name, company name, and your contact information for efficient processing of your request.

The technical support email address is soc_tech@microsemi.com.

7.5.2 My Cases

Microsemi SoC Products Group customers may submit and track technical cases online by going to [My Cases](#).

7.5.3 Outside the U.S.

Customers needing assistance outside the US time zones can either contact technical support via email (soc_tech@microsemi.com) or contact a local sales office. Visit [About Us](#) for [sales office listings](#) and [corporate contacts](#).

7.6 ITAR Technical Support

For technical support on RH and RT FPGAs that are regulated by International Traffic in Arms Regulations (ITAR), contact us via soc_tech@microsemi.com. Alternatively, within My Cases, select **Yes** in the ITAR drop-down list. For a complete list of ITAR-regulated Microsemi FPGAs, visit the ITAR web page.



**Microsemi Corporate
Headquarters**

One Enterprise, Aliso Viejo,
CA 92656 USA

Within the USA: +1 (800) 713-4113
Outside the USA: +1 (949) 380-6100
Sales: +1 (949) 380-6136
Fax: +1 (949) 215-4996
E-mail: sales.support@microsemi.com

© 2016 Microsemi Corporation. All rights reserved. Microsemi and the Microsemi logo are trademarks of Microsemi Corporation. All other trademarks and service marks are the property of their respective owners.

Microsemi Corporation (Nasdaq: MSCC) offers a comprehensive portfolio of semiconductor and system solutions for communications, defense & security, aerospace and industrial markets. Products include high-performance and radiation-hardened analog mixed-signal integrated circuits, FPGAs, SoCs and ASICs; power management products; timing and synchronization devices and precise time solutions, setting the world's standard for time; voice processing devices; RF solutions; discrete components; enterprise storage and communication solutions, security technologies and scalable anti-tamper products; Ethernet solutions; Power-over-Ethernet ICs and midspans; as well as custom design capabilities and services. Microsemi is headquartered in Aliso Viejo, Calif, and has approximately 4,800 employees globally. Learn more at www.microsemi.com.

Microsemi makes no warranty, representation, or guarantee regarding the information contained herein or the suitability of its products and services for any particular purpose, nor does Microsemi assume any liability whatsoever arising out of the application or use of any product or circuit. The products sold hereunder and any other products sold by Microsemi have been subject to limited testing and should not be used in conjunction with mission-critical equipment or applications. Any performance specifications are believed to be reliable but are not verified, and Buyer must conduct and complete all performance and other testing of the products, alone and together with, or installed in, any end-products. Buyer shall not rely on any data and performance specifications or parameters provided by Microsemi. It is the Buyer's responsibility to independently determine suitability of any products and to test and verify the same. The information provided by Microsemi hereunder is provided "as is, where is" and with all faults, and the entire risk associated with such information is entirely with the Buyer. Microsemi does not grant, explicitly or implicitly, to any party any patent rights, licenses, or any other IP rights, whether with regard to such information itself or anything described by such information. Information provided in this document is proprietary to Microsemi, and Microsemi reserves the right to make any changes to the information in this document or to any products and services at any time without notice.