PIC18-Q40 Family Programming Specification

Introduction

This programming specification describes an SPI-based programming method for the PIC18-Q40 family of microcontrollers. The [Programming Algorithms](#) section describes the programming commands, programming algorithms and electrical specifications used in that particular programming method. The [Appendix B](#) section contains individual part numbers, device identification values, pinout and packaging information, and Configuration Bytes.

**Important:**

- This is an SPI-compliant programming method with 8-bit commands.
- The low-voltage entry code is now 32 clocks and MSb first, unlike earlier PIC18 devices, which had 33 clocks and LSb first.

Table of Contents

Introduction.....	1
1. Overview.....	3
2. Memory Map.....	5
3. Programming Algorithms.....	10
4. Electrical Specifications.....	24
5. Appendix A: Revision History.....	26
6. Appendix B.....	27
The Microchip Website.....	37
Product Change Notification Service.....	37
Customer Support.....	37
Microchip Devices Code Protection Feature.....	37
Legal Notice.....	38
Trademarks.....	38
Quality Management System.....	39
Worldwide Sales and Service.....	40

1. Overview

1.1 Programming Data Flow

Nonvolatile Memory (NVM) programming data can be supplied by either the high-voltage In-Circuit Serial Programming™ (ICSP™) interface or the low-voltage ICSP interface. Data can be programmed into the Program Flash Memory (PFM), Data EEPROM, dedicated User ID locations and the Configuration Bytes.

1.2 Pin Utilization

Five pins are needed for ICSP programming. The pins are listed in the table below. For pin locations and packaging information, refer to the table in the “Appendix B” section.

Table 1-1. Pin Descriptions During Programming

Pin Name	During Programming		
	Function	Pin Type	Pin Description
ISCPCLK	ICSPCLK	I	Clock Input – Schmitt Trigger Input
ISCPDAT	ICSPDAT	I/O	Data Input/Output – Schmitt Trigger Input
MCLR/V _{PP}	Program/Verify mode	I ⁽¹⁾	Program Mode Select
V _{DD}	V _{DD}	P	Power Supply
V _{SS}	V _{SS}	P	Ground

Legend: I = Input, O = Output, P = Power

Note:

- The programming high voltage is internally generated. To activate the Program/Verify mode, high voltage needs to be applied to the MCLR input. Since the MCLR is used for a level source, MCLR does not draw any significant current.

1.3 Hardware Requirements

1.3.1 High-Voltage ICSP™ Programming

In High-Voltage ICSP mode, the device requires two programmable power supplies: One for V_{DD} and one for the MCLR/V_{PP} pin.

1.3.2 Low-Voltage ICSP™ Programming

In Low-Voltage ICSP mode, the device can be programmed using a single V_{DD} source in the device operating range. The MCLR/V_{PP} pin does not have to be brought to the programming voltage, but can instead be left at the normal operating voltage.

1.3.2.1 Single-Supply ICSP™ Programming

The device's LVP Configuration bit enables single-supply (low-voltage) ICSP programming. The LVP bit defaults to a '1' (enabled). The LVP bit may only be programmed to '0' by entering the High-Voltage ICSP mode, where the MCLR/V_{PP} pin is raised to V_{IHH}. Once the LVP bit is programmed to a '0', only the High-Voltage ICSP mode is available and can be used to program the device.



Important:

- The High-Voltage ICSP mode is always available, regardless of the state of the LVP bit, by applying V_{IH} to the \overline{MCLR}/V_{PP} pin.
- While in Low-Voltage ICSP mode, \overline{MCLR} is always enabled regardless of the MCLRE bit. Also, the \overline{MCLR} pin can no longer be used as a general purpose input.

1.4 Write and/or Erase Section

Erasing or writing is selected according to the command used to begin operation (see [Table 3-1](#)). The terminologies used in this document, related to erasing/writing to the program memory, are defined in the table below.

Table 1-2. Programming Terms

Term	Definition
Programmed Cell	A memory cell at logic '0'
Erased Cell	A memory cell at logic '1'
Erase	Change memory cell from a '0' to a '1'
Write	Change memory cell from a '1' to a '0'
Program	Generic erase and/or write

1.4.1 Erasing Memory

Memory is erased by 128-word pages or in bulk, where 'bulk' includes many subsets of the total memory space. The duration of the data memory erase is determined by the size of the data memory. All Bulk ICSP Erase commands have minimum V_{DD} requirements, which are higher than the Page Erase and Write requirements.

Page erasing pertains to PFM and User ID memory only. The configuration and data memory will be erased by the Bulk Erase command. For self-write operations, each byte write to data memory includes an automatic erase cycle for the location about to be programmed.

1.4.2 Writing Memory

Memory is written one word at a time. The duration of the write is determined internally.

Note: The size of the word is of 16 bits for the Program Flash Memory and of eight bits for the EEPROM, but the same 24-bit payload is used for both memory regions.

2. Memory Map

This section provides details on how the program memory and EEPROM are organized for this device.

Figure 2-1. Program and Data EEPROM Memory Map

Address	Device		
	PIC18Fx4Q40	PIC18Fx5Q40	PIC18Fx6Q40
00 0000h to 00 3FFFh	Program Flash Memory (8KW) ⁽¹⁾	Program Flash Memory (16 KW) ⁽¹⁾	Program Flash Memory (32 KW) ⁽¹⁾
00 4000h to 00 7FFFh	Not Present ⁽²⁾		
00 8000h to 00 FFFFh		Not Present ⁽²⁾	
01 0000h to 01 FFFFh			Not Present ⁽²⁾
02 0000h to 1F FFFFh			Not Present ⁽²⁾
20 0000h to 20 003Fh	User IDs (32 Words) ⁽³⁾		
20 0040h to 2B FFFFh	Reserved		
2C 0000h to 2C 00FFh	Device Information Area (DIA) ^(3,5)		
2C 0100h to 2F FFFFh	Reserved		
30 0000h to 30 0009h	Configuration Bytes ⁽³⁾		
30 000Ah to 37 FFFFh	Reserved		
38 0000h to 38 01FFh	Data EEPROM (512 Bytes)		
38 0200h to 3B FFFFh	Reserved		
3C 0000h to 3C 0009h	Device Configuration Information ^(3,4,5)		
3C 000Ah to 3F FFFBh	Reserved		
3F FFFCh to 3F FFFDh	Revision ID (1 Word) ^(3,4,5)		
3F FFFEh to 3F FFFFh	Device ID (1 Word) ^(3,4,5)		

- Notes:
1. Storage Area Flash is implemented as the last 128 Words of User Flash, if enabled.
 2. The addresses do not roll over. The region is read as '0'.
 3. Not code-protected.
 4. Hard-coded in silicon.
 5. This region cannot be written by the user and it is not affected by a Bulk Erase.

2.1 User ID Location

The user may store identification information (User ID) in 32 designated locations. The User ID locations are mapped to addresses 20 0000h-20 003Fh. Each location is 16 bits in length. Code protection has no effect on these memory locations. Each location may be read with code protection enabled or disabled.

2.2 Device/Revision ID

The 16-bit Device ID Word is located at the address 3F FFFEh and the 16-bit Revision ID is located at the address 3F FFFCh. These locations are read-only and cannot be erased or modified. See the [Device ID](#) and [Revision ID](#) registers for more details.

2.3 Device Configuration Information (DCI)

The Device Configuration Information (DCI) is a dedicated region in the memory that holds information about the device, which is useful for programming and bootloader applications. The data stored in this region are read-only and cannot be modified/erased. Refer to the table below for complete DCI table addresses and description.

Table 2-1. Device Configuration Information

Address	Name	Description	Value			Units
			PIC18F04/14Q40	PIC18F05/15Q40	PIC18F06/16Q40	
3C 0000h	ERSIZ	Erase page size	128			Words
3C 0002h	WLSIZ	Number of write latches per row	0			Words
3C 0004h	URSIZ	Number of user-erasable pages	64	128	256	Pages
3C 0006h	EESIZ	Data EEPROM memory size	512			Bytes
3C 0008h	PCNT	Pin count	14/20	14/20	14/20	Pins

2.4 Configuration Bytes

The devices have 10 Configuration Bytes, starting at address 30 0000h. The Configuration bits enable or disable specific features, placing these controls outside the normal software process, and they establish configured values prior to the execution of any software.

In terms of programming, consider the following Configuration bits:

- LVP: Low-Voltage Programming Enable bit**
 - 1 = ON: Low-Voltage Programming is enabled. $\overline{\text{MCLR}}/\text{V}_{\text{PP}}$ pin function is $\overline{\text{MCLR}}$. The MCLRE Configuration bit is ignored.
 - 0 = OFF: High voltage on $\overline{\text{MCLR}}/\text{V}_{\text{PP}}$ must be used for programming.



Important: The LVP bit cannot be written (to '0') while operating from the LVP programming interface. The purpose of this rule is to prevent the user from dropping out of LVP mode while programming from LVP mode, or accidentally eliminating LVP mode from the Configuration state. For more information, refer to [3.1.2 Low-Voltage Programming \(LVP\) Mode](#).

- MCLRE: Master Clear ($\overline{\text{MCLR}}$) Enable bit**
 - If LVP = 1: RA3 pin function is $\overline{\text{MCLR}}$

- If LVP = 0
 - 1 = RA3 pin is $\overline{\text{MCLR}}$
 - 0 = RA3 pin function is a port-defined function
- 3. **$\overline{\text{CP}}$: User NVM Program Memory Code Protection bit**
 - 1 = OFF: User NVM code protection is disabled
 - 0 = ON: User NVM code protection is enabled

For more information on code protection, see the [Code Protection](#) section.

2.5 Device ID

Name: DEVICEID
Address: 3F FFEh

Device ID Register

Bit	15	14	13	12	11	10	9	8
	DEV[15:8]							
Access	R	R	R	R	R	R	R	R
Reset	q	q	q	q	q	q	q	q
Bit	7	6	5	4	3	2	1	0
	DEV[7:0]							
Access	R	R	R	R	R	R	R	R
Reset	q	q	q	q	q	q	q	q

Bits 15:0 – DEV[15:0] Device ID

Device	Device ID
PIC18F04Q40	7640h
PIC18F05Q40	7600h
PIC18F06Q40	75C0h
PIC18F14Q40	7620h
PIC18F15Q40	75E0h
PIC18F16Q40	75A0h

2.6 Revision ID

Name: REVISIONID
Address: 3F FFFCh

Revision ID Register

Bit	15	14	13	12	11	10	9	8
	1010[3:0]				MJRREV[5:2]			
Access	R	R	R	R	R	R	R	R
Reset	1	0	1	0	q	q	q	q
Bit	7	6	5	4	3	2	1	0
	MJRREV[1:0]		MNRREV[5:0]					
Access	R	R	R	R	R	R	R	R
Reset	q	q	q	q	q	q	q	q

Bits 15:12 – 1010[3:0] Read as `\b1010`
These bits are fixed with value `\b1010` for all devices in this family.

Bits 11:6 – MJRREV[5:0] Major Revision ID
These bits are used to identify a major revision (A0, B0, C0, etc.).
Revision A = `\b00 0000`
Revision B = `\b00 0001`

Bits 5:0 – MNRREV[5:0] Minor Revision ID
These bits are used to identify a minor revision.
Revision A0 = `\b00 0000`
Revision B0 = `\b00 0000`
Revision B1 = `\b00 0001`



Tip: For example, the REVISIONID register value for revision B1 will be `0xA041`.

3. Programming Algorithms

3.1 Program/Verify Mode

In Program/Verify mode, the program memory and the configuration memory can be accessed and programmed in serial fashion. ICSPDAT and ICSPCLK are used for the data and the clock, respectively. All commands and data words are transmitted MSb first. Data changes on the rising edge of the ICSPCLK and is latched on the falling edge. In Program/Verify mode, both the ICSPDAT and ICSPCLK pins are Schmitt Trigger inputs. The sequence that enters the device into Program/Verify mode places all other logic into the Reset state; all I/Os are automatically configured as high-impedance inputs and the Program Counter (PC) is cleared.

3.1.1 High-Voltage Program/Verify Mode Entry and Exit

There are two different modes of entering Program/Verify mode via high voltage:

- V_{PP}-First Entry mode
- V_{DD}-First Entry mode

3.1.1.1 V_{PP}-First Entry Mode

To enter Program/Verify mode via the V_{PP}-First Entry mode, the following sequence must be followed:

1. Hold ICSPCLK and ICSPDAT low.
2. Raise the voltage on $\overline{\text{MCLR}}$ from 0V to V_{IHH}.
3. Raise the voltage on V_{DD} from 0V to the desired operating voltage.

The V_{PP}-First Entry mode prevents the device from executing code prior to entering the Program/Verify mode. For example, when the Configuration Byte has already been programmed to have $\overline{\text{MCLR}}$ disabled (MCLRE = 0), the Power-up Timer disabled ($\overline{\text{PWRTE}} = 0$) and the internal oscillator selected, the device will execute the code immediately. V_{PP}-First Entry mode is strongly recommended as it prevents the user code from executing. See the timing diagram in [Figure 3-1](#).

Figure 3-1. Programming Entry and Exit Modes – V_{PP}-First and Last

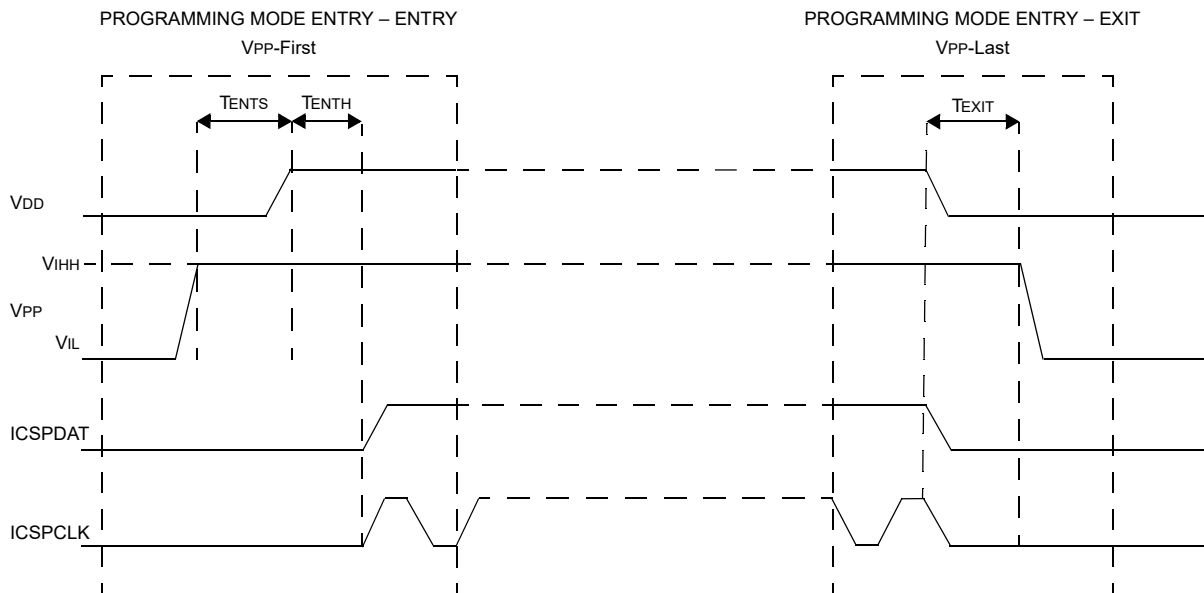

3.1.1.2 V_{DD}-First Entry Mode

To enter the Program/Verify mode via the V_{DD}-First Entry mode, the following sequence must be followed:

1. Hold ICSPCLK and ICSPDAT low.
2. Raise the voltage on V_{DD} from 0V to the desired operating voltage.
3. Raise the voltage on $\overline{\text{MCLR}}$ from V_{DD} or below to V_{IHH}.

The V_{DD}-First Entry mode is useful for programming the device when the V_{DD} is already applied. It is not necessary to disconnect V_{DD} to enter the Program/Verify mode. See the timing diagram in [Figure 3-2](#).

Figure 3-2. Programming Entry and Exit Modes – V_{DD}-First and Last

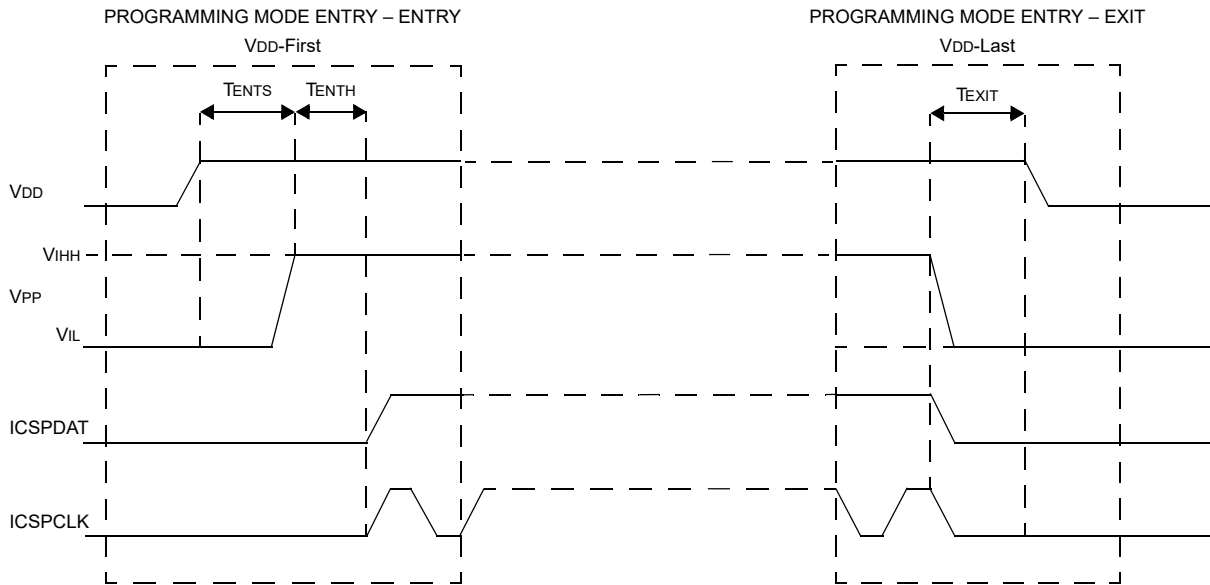

3.1.1.3 Program/Verify Mode Exit

To exit the Program/Verify mode, lower $\overline{\text{MCLR}}$ from V_{IHH} to V_{IL}. The V_{PP}-First Entry mode will use the V_{PP}-Last Exit mode (see [Figure 3-1](#)). The V_{DD}-First Entry mode will use the V_{DD}-Last Exit mode (see [Figure 3-2](#)).

3.1.2 Low-Voltage Programming (LVP) Mode

The Low-Voltage Programming mode allows the devices to be programmed using V_{DD} only, without high voltage. When the LVP bit in the Configuration Byte register is set to '1', the Low-Voltage ICSP Programming entry is enabled. To disable the Low-Voltage ICSP mode, the LVP bit must be programmed to '0'. This can only be done while in the High-Voltage Entry mode.

Entry into the Low-Voltage ICSP Program/Verify mode requires the following steps:

1. $\overline{\text{MCLR}}$ is brought to V_{IL}.
2. A 32-bit key sequence is presented on ICSPDAT, clocked by ICSPCLK. The Least Significant bit (LSb) of the pattern is a 'don't care X'. The Program/Verify mode entry pattern detect hardware verifies only the first 31 bits of the sequence and the last clock is required before the pattern detect goes active.

The key sequence is a specific 32-bit pattern, '32'h4d434850' (more easily remembered as MCHP in ASCII). The device will enter Program/Verify mode only if the sequence is valid. The Most Significant bit (MSb) of the Most Significant Byte must be shifted in first. Once the key sequence is complete, $\overline{\text{MCLR}}$ must be held at V_{IL} for as long as Program/Verify mode needs to be maintained. For Low-Voltage Programming timing, see [Figure 3-3](#) and [Figure 3-4](#).

Figure 3-3. LVP Entry (Powered)

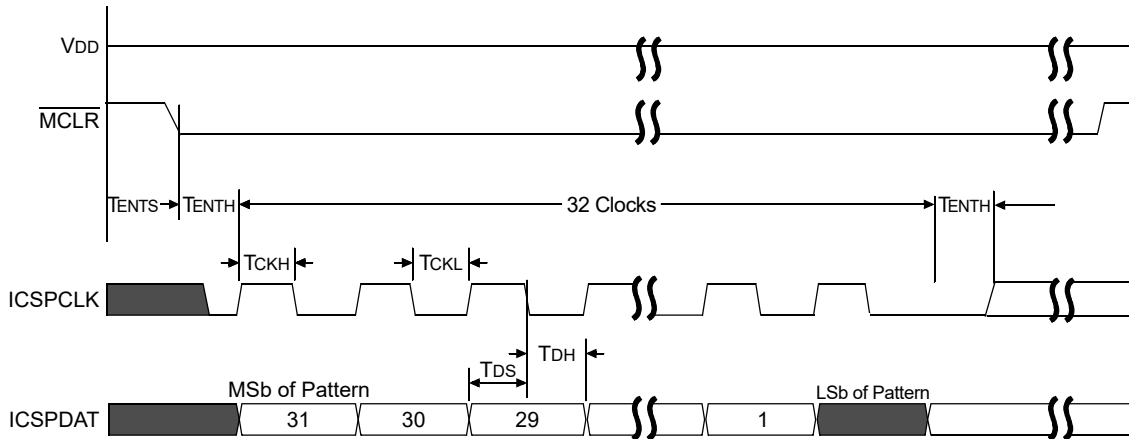
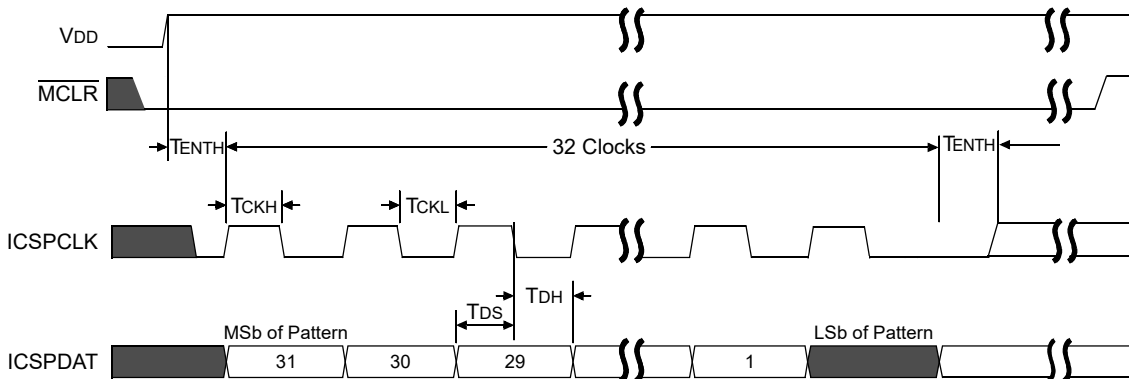

Figure 3-4. LVP Entry (Powering Up)



Exiting the Program/Verify mode is done by raising $\overline{\text{MCLR}}$ from below V_{IL} to V_{IH} level (or higher, up to V_{DD}).



Important:

To enter LVP mode, the MSb of the Most Significant nibble must be shifted in first. This differs from entering the key sequence on some other device families.

3.1.3 Program/Verify Commands

Once a device has entered the ICSP Program/Verify mode (using either high-voltage or LVP entry), the programming host device may issue six commands to the microcontroller, each eight bits in length. The commands are summarized in [Table 3-1](#) and are used to erase or program the device based on the location of the Program Counter (PC).

Some 8-bit commands also have an associated data payload (such as Load PC Address and Read Data from NVM).

If the host device issues an 8-bit command byte that has an associated data payload, the host device is responsible for sending additional 24 clock pulses (e.g., three 8-bit bytes) to send or receive the payload data associated with the command.

The payload field size is compatible with many 8-bit SPI-based systems. Within each 24-bit payload field, the first bit transmitted is always a Start bit, followed by a variable number of Pad bits, then by the useful data payload bits and ending with one Stop bit. The useful data payload bits are always transmitted MSb first.

When the programming device issues a command that involves a host to the microcontroller payload (e.g., Load PC Address), the Start, Stop and Pad bits will all be driven by the programmer to '0'. When the programming host device

issues a command that involves the microcontroller to host payload data (e.g., Read Data from NVM), the Start, Stop and Pad bits will be treated as ‘don’t care’ bits and the values will be ignored by the host.

When the programming host device issues an 8-bit command byte to the microcontroller, the host will wait a specified minimum amount of delay (which is command-specific) prior to sending any additional clock pulses (associated with either a 24-bit data payload field or the next command byte).

Table 3-1. ICSP™ Command Set Summary⁽¹⁾

Command Name	Command Value		Payload Expected	Delay after Command	Data/Note
	Binary (MSb ... LSb)	Hex			
Load PC Address	1000 0000	80	Yes	T _{DLY}	Payload value = PC
Bulk Erase	0001 1000	18	Yes	T _{ERAB}	The payload carries the information of the regions that need to be bulk erased
Page Erase Program Memory	1111 0000	F0	No	T _{ERAS}	The page addressed by the MSbs of the PC is erased; LSbs are ignored
Read Data from NVM	1111 11J0	FC/FE	Yes	T _{DLY}	Data output ‘0’ if code-protect is enabled; J = 0: PC is unchanged; J = 1: PC = PC + n ⁽²⁾ after reading
Increment Address	1111 1000	F8	No	T _{DLY}	PC = PC + n ⁽²⁾
Program Data	11J0 0000	C0/E0	Yes	T _{PROG}	Payload value = Data Word; J = 0: PC is unchanged; J = 1: PC = PC + n after writing



Important:

1. All the clock pulses for both the 8-bit commands and the 24-bit payload fields are generated by the host programming device. The microcontroller does not drive the ICSPCLK line. The ICSPDAT signal is a bidirectional data line. For all commands and payload fields, except the Read Data from NVM payload, the host programming device continuously drives the ICSPDAT line. Both the host programmer device and the microcontroller will latch received ICSPDAT values on the falling edge of the ICSPCLK line. When the microcontroller receives ICSPDAT line values from the host programmer, the ICSPDAT values must be valid a minimum of T_{DS} before the falling edges of ICSPCLK and will remain valid for a minimum of T_{DH} after the falling edge of ICSPDAT. See [Figure 3-5](#).
2. PC is incremented by n = 1 for data memory and Configuration Bytes, and n = 2 for all other regions.

Figure 3-5. Clock and Data Timing

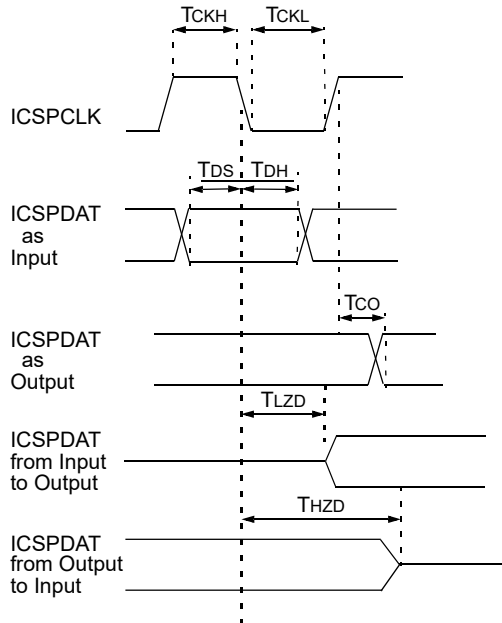

3.1.3.1 Program Data

The Program Data command is used to program one NVM word (e.g., one 16-bit instruction word for program memory/User ID memory or one 8-bit data for a Data EEPROM Memory address). The payload data are written into program or EEPROM memory immediately after the Programming Data command is issued (see [Programming Algorithms](#)). Depending on the value of bit 5 of the command, the PC may or may not be incremented (see [Table 3-1](#)).

Figure 3-6. Program Data (Program Memory and User IDs)

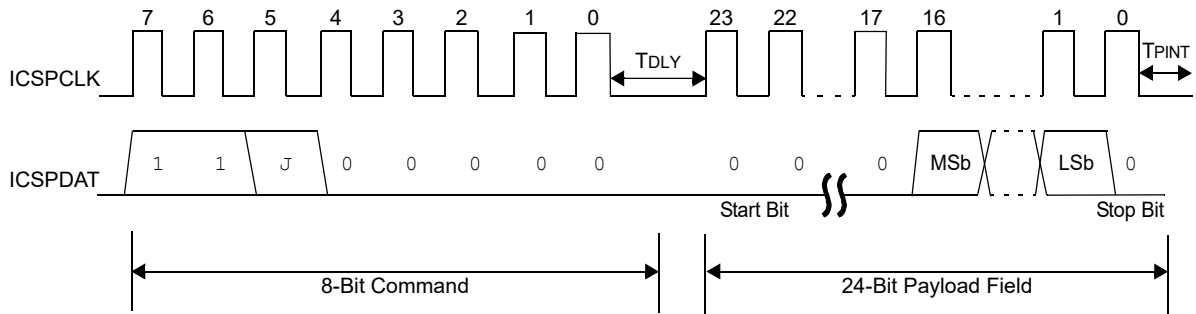
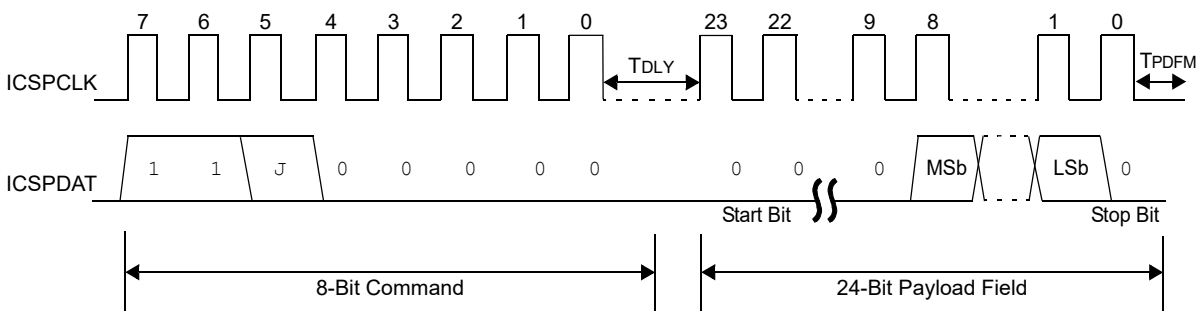

Figure 3-7. Program Data (DATA EEPROM and Configuration Bytes)



3.1.3.2 Read Data from NVM

The Read Data from the NVM command will transmit data bits out of the current PC address. The ICSPDAT pin will go into Output mode on the first falling edge of the ICSP data payload clock and it will revert to Input mode (high-impedance) after the 24th falling edge of the ICSP data payload clock. The Start and Stop bits are only one-half of a bit time wide. Therefore, they must be ignored by the host programmer device since the latched value may be indeterminate. Additionally, the host programmer device needs to only consider the MSb to LSb payload bits as valid and can ignore the values of the Pad bits. If the memory region is code-protected (\overline{CP} or \overline{DP}), the data will be read as zeros (see Figure 3-8 and Figure 3-9). Depending on the value of bit 1 of the command, the PC may or may not be incremented (see Table 3-1). The Read Data from the NVM command can be used to read data for the Program Flash Memory (see Figure 3-8) or the Data EEPROM Memory (see Figure 3-9).

Figure 3-8. Read Data from NVM (PFM and User IDs)

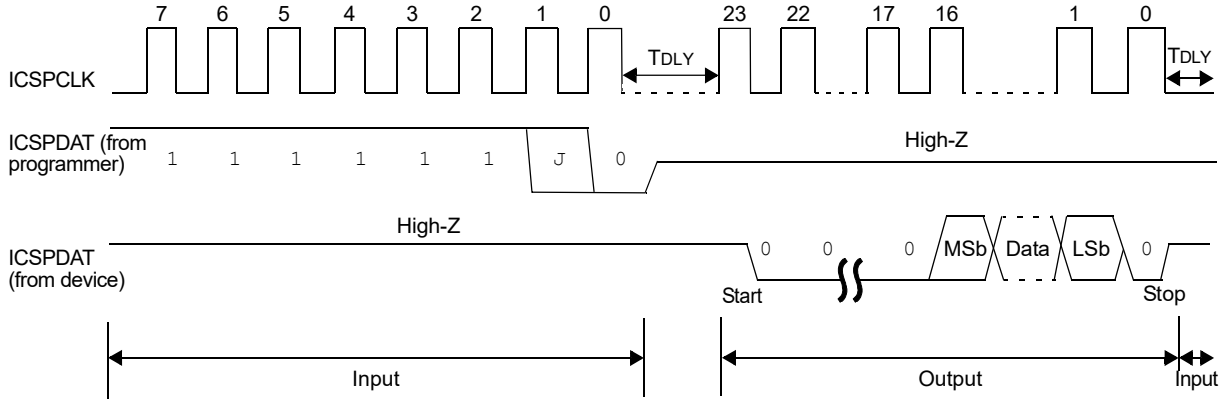
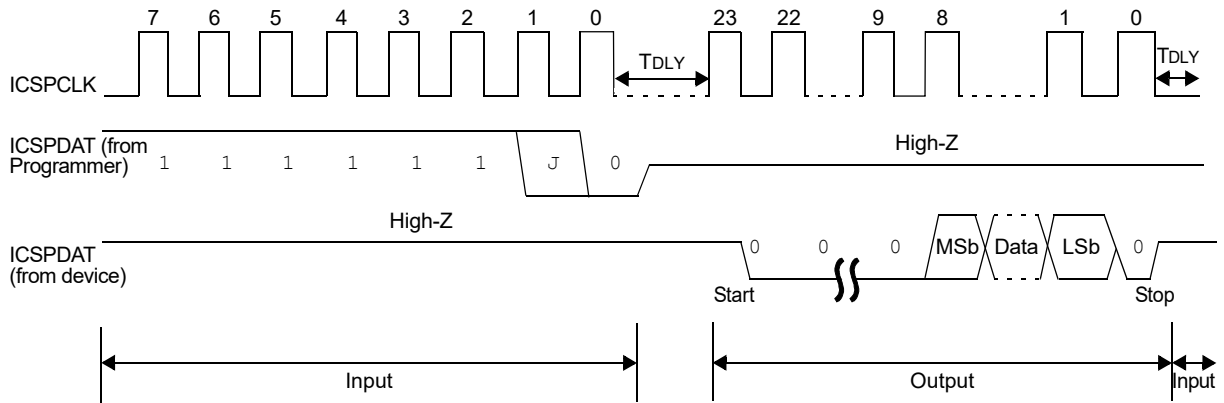

Figure 3-9. Read Data from NVM (DATA EEPROM and Configuration Bytes)



3.1.3.3 Increment Address

The address is incremented when this command is received. Depending on the current value of the Program Counter, the increment varies. If the PC points to PFM, then the PC is incremented by 2. If the PC points to the Data EEPROM or Configuration Space, then it is incremented by 1. It is not possible to decrement the address. To reset the Program Counter, the user must use the Load PC Address command.

Figure 3-10. Increment Address

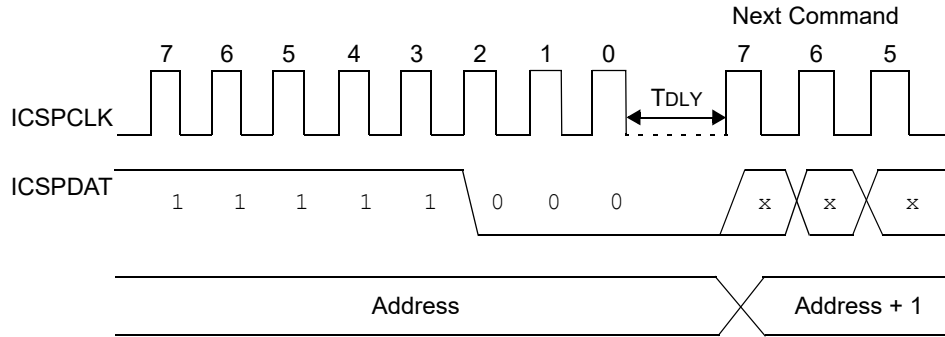

3.1.3.4 Load PC Address

The PC value is set using the supplied data. The address indicates the memory location (PFM or Data EEPROM Memory or Configuration memory) to be accessed (see [Figure 3-11](#)).

Figure 3-11. Load PC Address

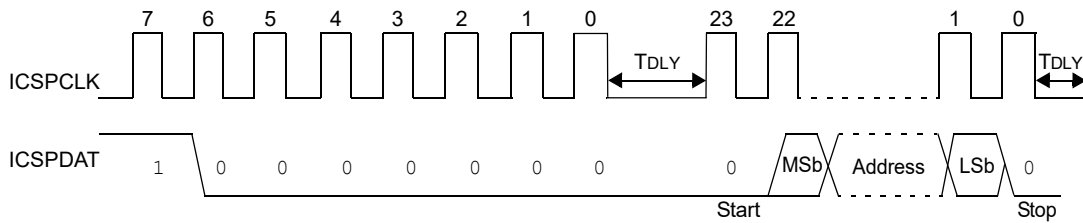

3.1.3.5 Bulk Erase

The Bulk Erase command is used to completely erase different memory regions. The area selection is a bit field in the payload.

By setting the following bits of the payload, the corresponding memory regions can be bulk erased. Setting multiple bits is valid.

1. Bit 0: Data EEPROM
2. Bit 1: Flash memory
3. Bit 2: User ID memory
4. Bit 3: Configuration memory



Important: If the device is code-protected and a Bulk Erase command for the Configuration memory is issued, all other regions are also bulk erased.

After receiving the Bulk Erase command, the erase will complete after the time interval, T_{ERAB} . See [Figure 3-12](#) for the Bulk Erase command structure.

Figure 3-12. Bulk Erase Memory

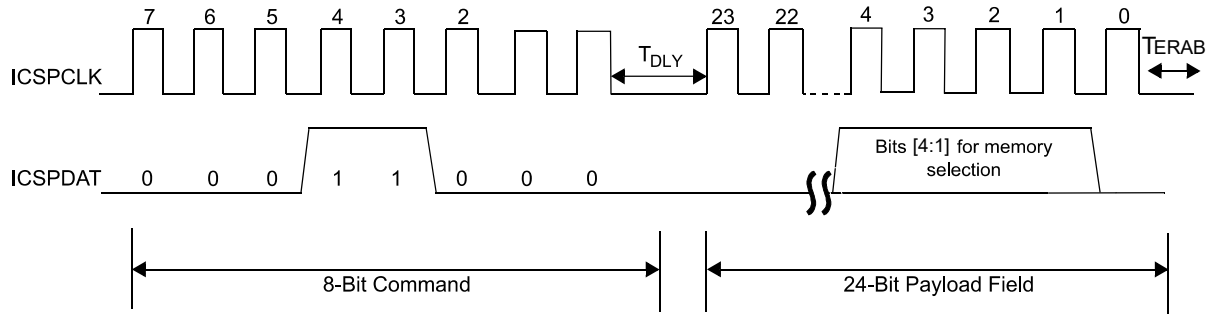

3.1.3.6 Page Erase Program Memory

The Page Erase Program Memory command will erase an individual page based on the current address of the Program Counter. If the program memory is code-protected, the Page Erase Memory command will be ignored. The Bulk Erase command must be used to erase code-protected memory.

The Flash memory page defined by the current PC will be erased. The user must wait T_{ERAS} for erasing to be complete (see Figure 3-13). Page Erase may be used for the program memory and User ID regions only. The configuration and data regions must be erased with the Bulk Erase method.

Figure 3-13. Page Erase Memory

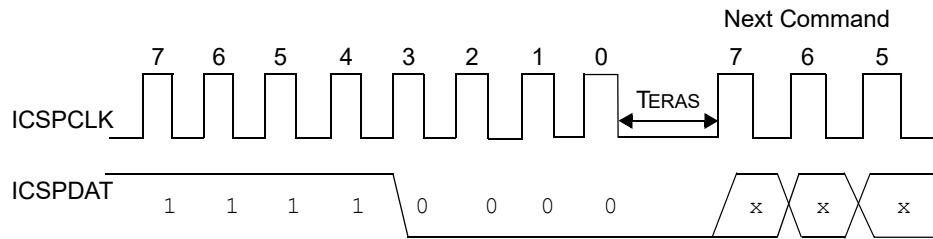

3.2 Programming Algorithms

The Program Flash Memory and User ID are programmed one word at a time. The EEPROM memory and configuration regions are programmed one byte at a time.

Figure 3-14. Device Program/Verify Flowchart

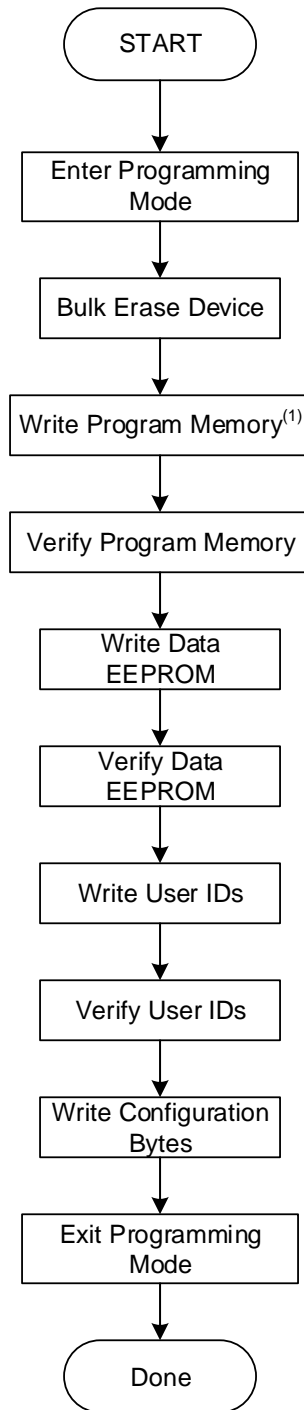

Notes:

1. See [Figure 3-15](#).
2. See [Figure 3-17](#).

Figure 3-15. Program Memory Flowchart

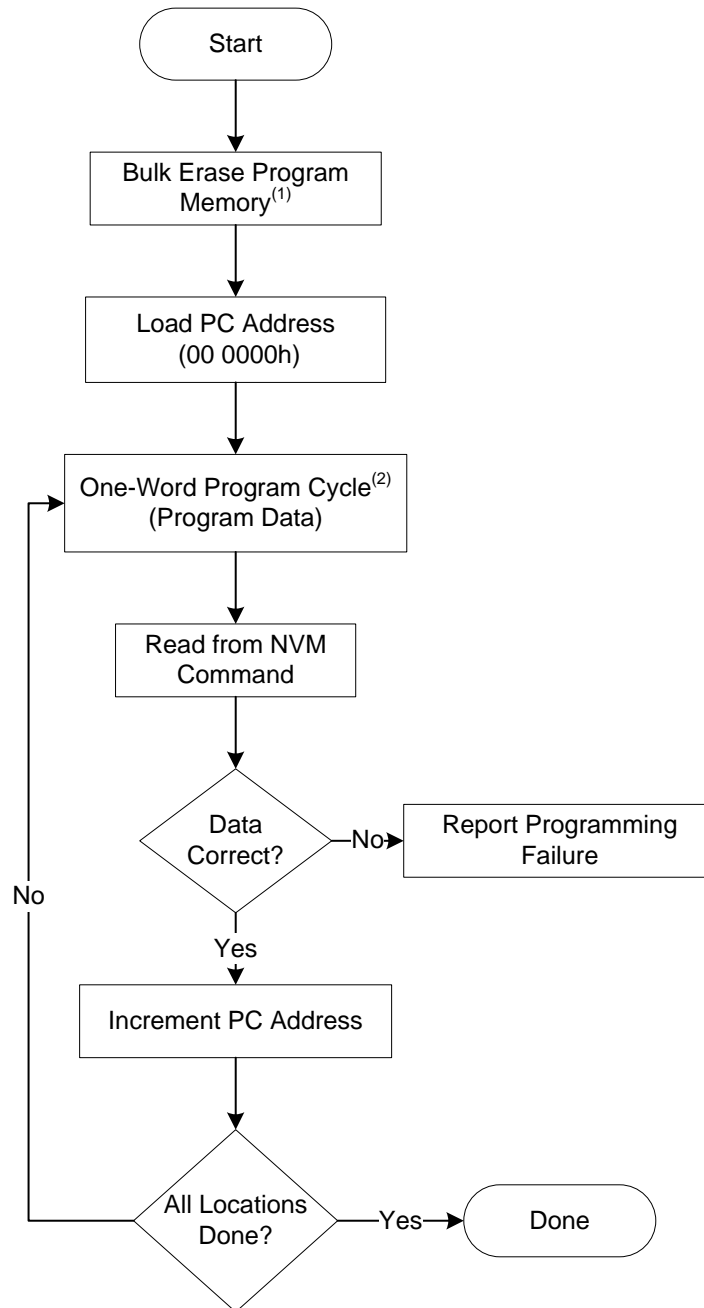

Notes:

1. This step is optional if the device has already been erased or has not been previously programmed.
2. If the device is code-protected or must be completely erased, then Bulk Erase the device, as shown in [Figure 3-18](#).

Figure 3-16. One-Word Program Cycle

Program Cycle
(For programming Data, EEPROM, User ID and Configuration Bytes)

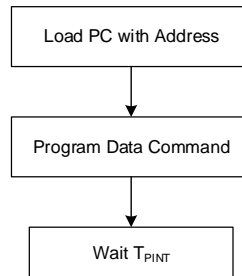
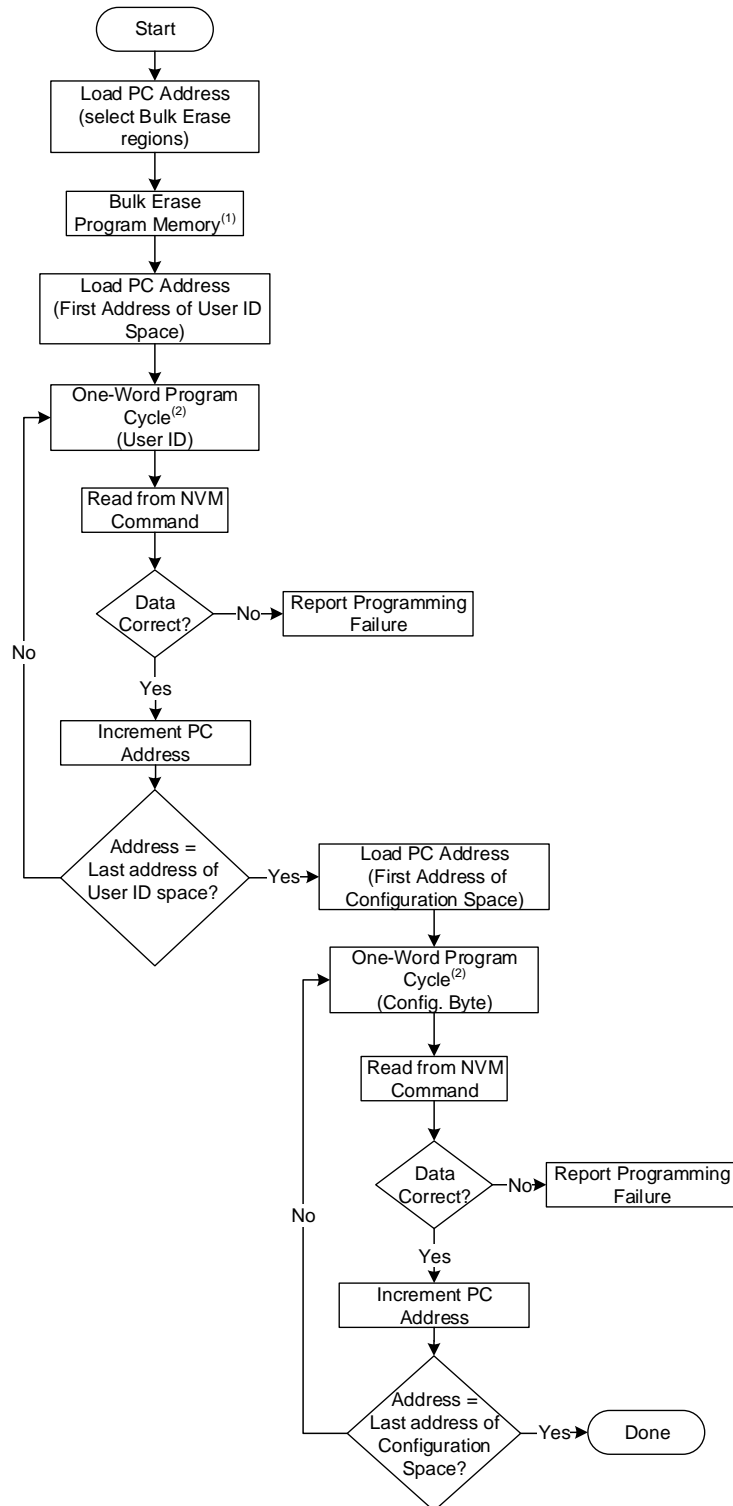

Figure 3-17. User ID and Configuration Memory Program Flowchart



Notes:

1. This step is optional if the device has already been erased or has not been previously programmed.
2. See [Figure 3-16](#).

Figure 3-18. Bulk Erase Flowchart

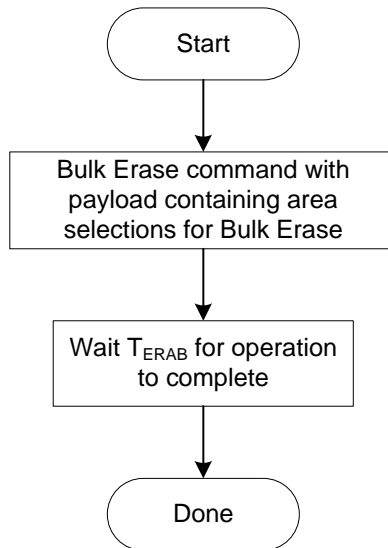

3.3 Code Protection

Code protection is controlled using the \overline{CP} bit. When code protection is enabled, all program memory and Data EEPROM locations read as '0'. Further programming is disabled for the program memory and Data EEPROM until a Bulk Erase operation is performed on the configuration memory region. The program memory and Data EEPROM can still be programmed and read during program execution.

The User ID locations and Configuration Bytes can be programmed and read out regardless of the code protection settings.

The only way to disable code protection is to use the Bulk Erase Program Memory command with bit 4 of the payload set to '1'. This will clear the disable code protection and erase all memory locations.

3.4 Hex File Usage

3.4.1 Embedding Configuration Information in the Hex File

To allow the portability of the code, a programmer is required to read the Configuration Byte locations from the hex file. If the Configuration Byte information is not present in the hex file, then a simple warning message will be issued. Similarly, when saving a hex file, all the Configuration Byte information will be included. An option not to include the Configuration Byte information may be provided. When embedding Configuration Byte information in the hex file, it will start at address 30 0000h.



Important:

This feature is highly important for the benefit of the end customer.

3.4.2 Embedding Data EEPROM Information in the Hex File

To allow the portability of the code, a programmer is required to read the Data EEPROM information from the hex file. If Data EEPROM information is not present, a simple warning message will be issued. Similarly, when saving a hex file, all Data EEPROM information must be included. An option not to include the Data EEPROM information may be provided. When embedding Data EEPROM information in the hex file, it will start at address 38 0000h.



Important:

This feature is highly important for the benefit of the end customer.

3.5 CRC Checksum Computation

Unlike older PIC[®] devices, the Microchip toolchain runs a 32-bit CRC calculation on the entire hex file to calculate its checksum. The checksum uses the standard CRC-32 algorithm with the polynomial $0x4C11DB7$ ($x^{32} + x^{26} + x^{23} + x^{22} + x^{16} + x^{12} + x^{11} + x^{10} + x^8 + x^7 + x^5 + x^4 + x^2 + x + 1$).

4. Electrical Specifications

Refer to the device specific data sheet for absolute maximum ratings.

Table 4-1. AC/DC Characteristics Timing Requirements for Program/Verify Mode

AC/DC Characteristics		Standard Operating Conditions Production Tested at +25°C				
Sym.	Characteristics	Min.	Typ.	Max.	Units	Conditions/Comments
Programming Supply Voltages and Currents						
V _{DD}	Supply Voltage (V _{DDMIN} , V _{DDMAX})	1.80	—	5.50	V	(Note 1)
V _{PEW}	Read/Write and Page Erase Operations	V _{DDMIN}	—	V _{DDMAX}	V	
V _{BE}	Bulk Erase Operations	V _{BORMAX}	—	V _{DDMAX}	V	(Note 2)
I _{DDI}	Current on V _{DD} , Idle	—	—	1.0	mA	
I _{DDP}	Current on V _{DD} , Programming	—	—	10	mA	
I _{PP}	V_{PP}					
	Current on $\overline{\text{MCLR}}/V_{PP}$	—	—	600	μA	
V _{IHH}	High Voltage on $\overline{\text{MCLR}}/V_{PP}$ for Program/Verify Mode Entry	7.9	—	9.0	V	
T _{VHHR}	$\overline{\text{MCLR}}$ Rise Time (V _{IL} to V _{IHH}) for Program/Verify Mode Entry	—	—	1.0	μs	
I/O Pins						
V _{IH}	(ICSPCLK, ICSPDAT, $\overline{\text{MCLR}}/V_{PP}$) Input High Level	0.8 V _{DD}	—	V _{DD}	V	
V _{IL}	(ICSPCLK, ICSPDAT, $\overline{\text{MCLR}}/V_{PP}$) Input Low Level	V _{SS}	—	0.2 V _{DD}	V	
V _{OH}	ICSPDAT Output High Level	V _{DD} - 0.7	—	—	V	I _{OH} = 3 mA, V _{DD} = 3.0V
V _{OL}	ICSPDAT Output Low Level	—	—	V _{SS} + 0.6	V	I _{OL} = 6 mA, V _{DD} = 3.0V
Programming Mode Entry and Exit						
T _{ENTS}	Programming Mode Entry Setup Time: ICSPCLK, ICSPDAT Setup Time before V _{DD} or $\overline{\text{MCLR}}\uparrow$	100	—	—	ns	
T _{ENTH}	Programming Mode Entry Hold Time: ICSPCLK, ICSPDAT Hold Time before V _{DD} or $\overline{\text{MCLR}}\uparrow$	1	—	—	ms	
Serial Program/Verify						
T _{CKL}	Clock Low Pulse Width	100	—	—	ns	
T _{CKH}	Clock High Pulse Width	100	—	—	ns	
T _{DS}	Data in Setup Time before Clock \downarrow	100	—	—	ns	
T _{DH}	Data in Hold Time after Clock \downarrow	100	—	—	ns	
T _{CO}	Clock \uparrow to Data Out Valid (during a Read Data command)	0	—	80	ns	
T _{LZD}	Clock \downarrow to Data Low-Impedance (during a Read Data from NVM command)	0	—	80	ns	
T _{HZD}	Clock \downarrow to Data High-Impedance (during a Read Data from NVM command)	0	—	80	ns	
T _{DLY}	Data Input not Driven to Next Clock Input (delay required between command/data or command/command)	1.0	—	—	μs	
T _{ERAB}	Bulk Erase Cycle Time	—	—	11	ms	Program, Config and ID
T _{ERAS}	Page Erase Cycle Time	—	—	11	ms	
T _{PDFM}	Internally Timed DFM (EEPROM) Programming Operation Time	—	—	11	ms	EEPROM and Configuration Bytes
T _{PINT}	Internally Timed Programming Operation Time	—	—	75	μs	Program Memory and User IDs

.....continued

AC/DC Characteristics		Standard Operating Conditions Production Tested at +25°C				
Sym.	Characteristics	Min.	Typ.	Max.	Units	Conditions/Comments
T _{EXIT}	Time Delay when Exiting Program/Verify Mode	1	—	—	µs	

Notes:

1. Bulk erased devices default to Brown-out Reset enabled with BORV = 11 (low trip point). V_{DDMIN} is the V_{BOR} threshold (with BORV = 1) when performing Low-Voltage Programming on a bulk erased device to ensure that the device is not held in Brown-out Reset.
2. The hardware requires V_{DD} to be above the BOR threshold, at the ~2.85V nominal setting, to perform Bulk Erase operations. This threshold does not depend on the BORV Configuration bit settings. Refer to the microcontroller device data sheet specifications for min./typ./max. limits of the V_{BOR} level.

5. Appendix A: Revision History

Doc Rev.	Date	Comments
C	07/2021	Updated Table 4-1 and Sections 2.6, 3.1.2 and 6.3. Minor editorial corrections.
B	11/2020	Updated Note 2 in Table 4-1
A	02/2020	Initial document release

6. Appendix B

This section provides information about the device IDs and pinout descriptions.

Table 6-1. Programming Pin Locations by Package Type

Device	Package	Package Code	V _{DD}	V _{SS}	MCLR		ICSPCLK		ICSPDAT	
			PIN	PIN	PIN	PORT	PIN	PORT	PIN	PORT
PIC18F04Q40 PIC18F05Q40 PIC18F06Q40	14-Pin SOIC	SL	1	14	4	RA3	12	RA1	13	RA0
	14-Pin TSSOP	ST	1	14	4	RA3	12	RA1	13	RA0
PIC18F14Q40 PIC18F15Q40 PIC18F16Q40	20-Pin PDIP	P	1	20	4	RA3	18	RA1	19	RA0
	20-Pin SOIC	SO	1	20	4	RA3	18	RA1	19	RA0
	20-Pin SSOP	SS	1	20	4	RA3	18	RA1	19	RA0
	20-Pin VQFN	REB	18	17	1	RA3	15	RA1	16	RA0

Note:

The most current package drawings are located in the Microchip Packaging Specification, DS00000049 (<http://www.microchip.com/packaging>). The drawing numbers listed above do not include the current revision designator, which is added at the end of the number.

6.1 CONFIG1

Name: CONFIG1
Address: 30 0000h

Configuration Byte 1

Bit	7	6	5	4	3	2	1	0
		RSTOSC[2:0]				FEXTOSC[2:0]		
Access		R/W	R/W	R/W		R/W	R/W	R/W
Reset		1	1	1		1	1	1

Bits 6:4 – RSTOSC[2:0] Power-Up Default Value for COSC

This value is the Reset default value for COSC and selects the oscillator first used by user software. Refer to COSC operation.

Value	Description
111	EXTOSC operating per FEXTOSC bits
110	HFINTOSC with HFFRQ = 4 MHz and CDIV = 4:1. Resets COSC/NOSC to b'110'.
101	LFINTOSC
100	SOSC
011	Reserved
010	EXTOSC with 4x PLL, with EXTOSC operating per FEXTOSC bits
001	Reserved
000	HFINTOSC with HFFRQ = 64 MHz and CDIV = 1:1. Resets COSC/NOSC to b'110'.

Bits 2:0 – FEXTOSC[2:0] External Oscillator Mode Selection

Value	Description
111	ECH (external clock) above 8 MHz
110	ECM (external clock) for 500 kHz to 8 MHz
101	ECL (external clock) below 500 kHz
100	Oscillator not enabled
011	Reserved (do not use)
010	HS (crystal oscillator) above 4 MHz
001	XT (crystal oscillator) above 500 kHz, below 4 MHz
000	LP (crystal oscillator) optimized for 32.768 kHz

6.2 CONFIG2

Name: CONFIG2
Address: 30 0001h

Configuration Byte 2

Bit	7	6	5	4	3	2	1	0
	FCMENS	FCMENP	FCMEN		CSWEN		PR1WAY	CLKOUTEN
Access	R/W	R/W	R/W		R/W		R/W	R/W
Reset	1	1	1		1		1	1

Bit 7 – FCMENS Fail-Safe Clock Monitor Enable - Secondary XTAL Enable

Value	Description
1	Fail-Safe Clock Monitor enabled; the timer will flag the FSCMS bit and OSFIF interrupt on SOSC failure
0	Fail-Safe Clock Monitor disabled

Bit 6 – FCMENP Fail-Safe Clock Monitor Enable - Primary XTAL Enable

Value	Description
1	Fail-Safe Clock Monitor enabled; the timer will flag the FSCMP bit and OSFIF interrupt on EXTOSC failure
0	Fail-Safe Clock Monitor disabled

Bit 5 – FCMEN Fail-Safe Clock Monitor Enable

Value	Description
1	Fail-Safe Clock Monitor enabled
0	Fail-Safe Clock Monitor disabled

Bit 3 – CSWEN Clock Switch Enable

Value	Description
1	Writing to NOSC and NDIV is allowed
0	The NOSC and NDIV bits cannot be changed by user software

Bit 1 – PR1WAY PRLOCKED One-Way Set Enable

Value	Description
1	The PRLOCKED bit can be cleared and set only once; Priority registers remain locked after one clear/set cycle
0	The PRLOCKED bit can be set and cleared repeatedly (subject to the unlock sequence)

Bit 0 – CLKOUTEN Clock Out Enable

If FEXTOSC = HS, XT, LP, then this bit is ignored.

Otherwise:

Value	Description
1	CLKOUT function is disabled; I/O function on OSC2
0	CLKOUT function is enabled; F _{OSC} /4 clock appears at OSC2

6.3 CONFIG3

Name: CONFIG3
Address: 30 0002h

Configuration Byte 3

Bit	7	6	5	4	3	2	1	0
	BOREN[1:0]		LPBOREN	IVT1WAY	MVECEN	PWRTS[1:0]		MCLRE
Access	R/W	R/W	R/W	R/W	R/W	R/W	R/W	R/W
Reset	0	1	1	1	1	1	1	1

Bits 7:6 – BOREN[1:0] Brown-out Reset Enable

When enabled, Brown-out Reset Voltage (V_{BOR}) is set by the BORV bit.

Value	Description
11	Brown-out Reset enabled, the SBOREN bit is ignored
10	Brown-out Reset enabled while running, disabled in Sleep; SBOREN is ignored
01	Brown-out Reset enabled according to SBOREN
00	Brown-out Reset disabled

Bit 5 – LPBOREN Low-Power BOR Enable

Value	Description
1	Low-Power Brown-out Reset is disabled
0	Low-Power Brown-out Reset is enabled

Bit 4 – IVT1WAY IVTLOCK One-Way Set Enable

Value	Description
1	The IVTLOCK bit can be cleared and set only once; IVT registers remain locked after one clear/set cycle
0	The IVTLOCK bit can be set and cleared repeatedly (subject to the unlock sequence)

Bit 3 – MVECEN Multivector Enable

Value	Description
1	Multivector is enabled; vector table used for interrupts
0	Legacy interrupt behavior

Bits 2:1 – PWRTS[1:0] Power-up Timer Selection

Value	Description
11	PWRT is disabled
10	PWRT is set at 64 ms
01	PWRT is set at 16 ms
00	PWRT is set at 1 ms

Bit 0 – MCLRE Master Clear (\overline{MCLR}) Enable

Value	Condition	Description
x	If LVP = 1	RA3 pin function is \overline{MCLR}
1	If LVP = 0	RA3 pin function is \overline{MCLR}
0	If LVP = 0	RA3 pin function is a port-defined function

6.4 CONFIG4

Name: CONFIG4
Address: 30 0003h

Configuration Byte 4

Bit	7	6	5	4	3	2	1	0
	XINST		LVP	STVREN	PPS1WAY	ZCD	BORV[1:0]	
Access	R/W		R/W	R/W	R/W	R/W	R/W	R/W
Reset	1		1	1	1	1	1	1

Bit 7 – XINST Extended Instruction Set Enable

Value	Description
1	Extended Instruction Set and Indexed Addressing mode disabled (Legacy mode)
0	Extended Instruction Set and Indexed Addressing mode enabled

Bit 5 – LVP Low-Voltage Programming Enable

The LVP bit cannot be written (to zero) while operating from the LVP programming interface. The purpose of this rule is to prevent the user from dropping out of LVP mode while programming from LVP mode, or accidentally eliminating LVP mode from the Configuration state.

Value	Description
1	Low-Voltage Programming enabled. MCLR/V _{PP} pin function is MCLR. The MCLRE Configuration bit is ignored.
0	HV on MCLR/V _{PP} must be used for programming

Bit 4 – STVREN Stack Overflow/Underflow Reset Enable

Value	Description
1	Stack Overflow or Underflow will cause a Reset
0	Stack Overflow or Underflow will not cause a Reset

Bit 3 – PPS1WAY PPSLOCKED One-Way Set Enable

Value	Description
1	The PPSLOCKED bit can only be set once after an unlocking sequence is executed; once PPSLOCK is set, all future changes to PPS registers are prevented
0	The PPSLOCKED bit can be set and cleared as needed (unlocking sequence is required)

Bit 2 – ZCD ZCD Disable

Value	Description
1	ZCD disabled, ZCD can be enabled by setting the ZCDSEN bit of ZCDCON
0	ZCD always enabled, PMDx[ZCDMD] bit is ignored

Bits 1:0 – BORV[1:0] Brown-out Reset Voltage Selection⁽¹⁾

Value	Description
11	Brown-out Reset Voltage (V _{BOR}) set to 1.90V
10	Brown-out Reset Voltage (V _{BOR}) set to 2.45V
01	Brown-out Reset Voltage (V _{BOR}) set to 2.7V
00	Brown-out Reset Voltage (V _{BOR}) set to 2.85V

Note:

1. The higher voltage setting is recommended for an operation at or above 16 MHz.

6.5 CONFIG5

Name: CONFIG5
Address: 30 0004h

Configuration Byte 5

Bit	7	6	5	4	3	2	1	0
		WDTE[1:0]			WDTCP5[4:0]			
Access		R/W	R/W	R/W	R/W	R/W	R/W	R/W
Reset		1	1	1	1	1	1	1

Bits 6:5 – WDTE[1:0] WDT Operating Mode

Value	Description
11	WDT enabled regardless of Sleep; the SEN bit in WDTCON0 is ignored
10	WDT enabled while Sleep = 0, suspended when Sleep = 1; the SEN bit in WDTCON0 is ignored
01	WDT enabled/disabled by the SEN bit in WDTCON0
00	WDT disabled, the SEN bit in WDTCON0 is ignored

Bits 4:0 – WDTCP5[4:0] WDT Period Select

WDTCP5	WDTCON0[WDTPS] at POR			Typical Time-Out (F _{IN} = 31 kHz)	Software Control of WDTPS?
	Value	Divider Ratio			
11111	01011	1:65536	2 ¹⁶	2s	Yes
11110 to 10011	11110 to 10011	1:32	2 ⁵	1 ms	No
10010	10010	1:8388608	2 ²³	256s	No
10001	10001	1:4194304	2 ²²	128s	No
10000	10000	1:2097152	2 ²¹	64s	No
01111	01111	1:1048576	2 ²⁰	32s	No
01110	01110	1:524288	2 ¹⁹	16s	No
01101	01101	1:262144	2 ¹⁸	8s	No
01100	01100	1:131072	2 ¹⁷	4s	No
01011	01011	1:65536	2 ¹⁶	2s	No
01010	01010	1:32768	2 ¹⁵	1s	No
01001	01001	1:16384	2 ¹⁴	512 ms	No
01000	01000	1:8192	2 ¹³	256 ms	No
00111	00111	1:4096	2 ¹²	128 ms	No
00110	00110	1:2048	2 ¹¹	64 ms	No
00101	00101	1:1024	2 ¹⁰	32 ms	No
00100	00100	1:512	2 ⁹	16 ms	No
00011	00011	1:256	2 ⁸	8 ms	No
00010	00010	1:128	2 ⁷	4 ms	No
00001	00001	1:64	2 ⁶	2 ms	No
00000	00000	1:32	2 ⁵	1 ms	No

6.6 CONFIG6

Name: CONFIG6
Address: 30 0005h

Configuration Byte 6

Bit	7	6	5	4	3	2	1	0
			WDTCCS[2:0]			WDCWS[2:0]		
Access			R/W	R/W	R/W	R/W	R/W	R/W
Reset			1	1	1	1	1	1

Bits 5:3 – WDTCCS[2:0] WDT Input Clock Selector

Value	Condition	Description
x	WDTE = 00	These bits have no effect
111	WDTE ≠ 00	Software control
110 to 011	WDTE ≠ 00	Reserved
010	WDTE ≠ 00	WDT reference clock is the SOSC
001	WDTE ≠ 00	WDT reference clock is the 31.25 kHz MFINTOSC
000	WDTE ≠ 00	WDT reference clock is the 31.0 kHz LFINTOSC

Bits 2:0 – WDCWS[2:0] WDT Window Select

WDCWS	WDTCON1[WINDOW] at POR			Software Control of WINDOW	Keyed Access Required?
	Value	Window Delay Percent of Time	Window Opening Percent of Time		
111	111	n/a	100	Yes	No
110	110	n/a	100		
101	101	25	75		
100	100	37.5	62.5	No	Yes
011	011	50	50		
010	010	62.5	37.5		
001	001	75	25		
000	000	87.5	12.5		

6.7 CONFIG7

Name: CONFIG7
Address: 30 0006h

Configuration Byte 7

Bit	7	6	5	4	3	2	1	0
			DEBUG	SAFEN	BBEN	BBSIZE[2:0]		
Access			R/W	R/W	R/W	R/W	R/W	R/W
Reset			1	1	1	1	1	1

Bit 5 – DEBUG Debugger Enable

Value	Description
1	Background debugger disabled
0	Background debugger enabled

Bit 4 – SAFEN Storage Area Flash (SAF) Enable⁽¹⁾

Value	Description
1	SAF is disabled
0	SAF is enabled

Bit 3 – BBEN Boot Block Enable⁽¹⁾

Value	Description
1	Boot Block is disabled
0	Boot Block is enabled

Bits 2:0 – BBSIZE[2:0] Boot Block Size Selection⁽²⁾

Table 6-2. Boot Block Size

BBEN	BBSIZE	End Address of Boot Block	Boot Block Size (words)		
			PIC18FX4Q40	PIC18FX5Q40	PIC18FX6Q40
1	xxx	—	—		
0	111	00 03FFh	512		
0	110	00 07FFh	1024		
0	101	00 0FFFh	2048		
0	100	00 1FFFh	4096		
0	011	00 3FFFh	—	8192	
0	010	00 7FFFh	—		16384
0	001	00 FFFFh	—		
0	000	01 FFFFh	—		

Notes:

- Once protection is enabled through ICSP™ or a self-write, it can only be reset through a Bulk Erase.
- BBSIZE[2:0] bits can only be changed when BBEN = 1. Once BBEN = 0, BBSIZE[2:0] can only be changed through a Bulk Erase.

6.8 CONFIG8

Name: CONFIG8
Address: 30 0007h

Configuration Byte 8

Bit	7	6	5	4	3	2	1	0
	$\overline{\text{WRTAPP}}$				$\overline{\text{WRTSAF}}$	$\overline{\text{WRTD}}$	$\overline{\text{WRTC}}$	$\overline{\text{WRTB}}$
Access	R/W				R/W	R/W	R/W	R/W
Reset	1				1	1	1	1

Bit 7 – $\overline{\text{WRTAPP}}$ Application Block Write Protection⁽¹⁾

Value	Description
1	Application Block is not write-protected
0	Application Block is write-protected

Bit 3 – $\overline{\text{WRTSAF}}$ Storage Area Flash (SAF) Write Protection^(1,2)

Value	Description
1	SAF is not write-protected
0	SAF is write-protected

Bit 2 – $\overline{\text{WRTD}}$ Data EEPROM Write Protection⁽¹⁾

Value	Description
1	Data EEPROM is not write-protected
0	Data EEPROM is write-protected

Bit 1 – $\overline{\text{WRTC}}$ Configuration Register Write Protection⁽¹⁾

Value	Description
1	Configuration registers are not write-protected
0	Configuration registers are write-protected

Bit 0 – $\overline{\text{WRTB}}$ Boot Block Write Protection^(1,3)

Value	Description
1	Boot Block is not write-protected
0	Boot Block is write-protected

Notes:

- Once protection is enabled through ICSP™ or a self-write, it can only be reset through a Bulk Erase.
- Applicable only if $\overline{\text{SAFEN}} = 0$.
- Applicable only if $\overline{\text{BBEN}} = 0$.

6.9 CONFIG9

Name: CONFIG9
Address: 30 0008h

Configuration Byte 9

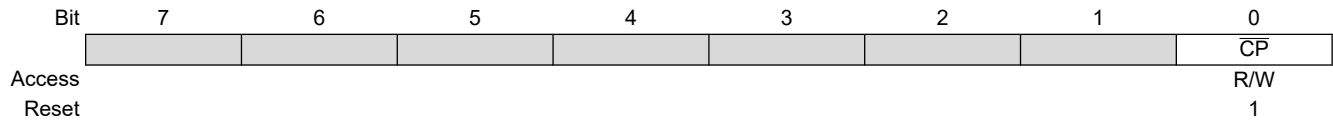

Bit 0 – \overline{CP} User Program Flash Memory and Data EEPROM Code Protection

Value	Description
1	User Program Flash Memory and Data EEPROM code protection are disabled
0	User Program Flash Memory and Data EEPROM code protection are enabled

The Microchip Website

Microchip provides online support via our website at www.microchip.com/. This website is used to make files and information easily available to customers. Some of the content available includes:

- **Product Support** – Data sheets and errata, application notes and sample programs, design resources, user's guides and hardware support documents, latest software releases and archived software
- **General Technical Support** – Frequently Asked Questions (FAQs), technical support requests, online discussion groups, Microchip design partner program member listing
- **Business of Microchip** – Product selector and ordering guides, latest Microchip press releases, listing of seminars and events, listings of Microchip sales offices, distributors and factory representatives

Product Change Notification Service

Microchip's product change notification service helps keep customers current on Microchip products. Subscribers will receive email notification whenever there are changes, updates, revisions or errata related to a specified product family or development tool of interest.

To register, go to www.microchip.com/pcn and follow the registration instructions.

Customer Support

Users of Microchip products can receive assistance through several channels:

- Distributor or Representative
- Local Sales Office
- Embedded Solutions Engineer (ESE)
- Technical Support

Customers should contact their distributor, representative or ESE for support. Local sales offices are also available to help customers. A listing of sales offices and locations is included in this document.

Technical support is available through the website at: www.microchip.com/support

Microchip Devices Code Protection Feature

Note the following details of the code protection feature on Microchip devices:

- Microchip products meet the specifications contained in their particular Microchip Data Sheet.
- Microchip believes that its family of products is secure when used in the intended manner and under normal conditions.
- There are dishonest and possibly illegal methods being used in attempts to breach the code protection features of the Microchip devices. We believe that these methods require using the Microchip products in a manner outside the operating specifications contained in Microchip's Data Sheets. Attempts to breach these code protection features, most likely, cannot be accomplished without violating Microchip's intellectual property rights.
- Microchip is willing to work with any customer who is concerned about the integrity of its code.
- Neither Microchip nor any other semiconductor manufacturer can guarantee the security of its code. Code protection does not mean that we are guaranteeing the product is "unbreakable." Code protection is constantly evolving. We at Microchip are committed to continuously improving the code protection features of our products. Attempts to break Microchip's code protection feature may be a violation of the Digital Millennium Copyright Act. If such acts allow unauthorized access to your software or other copyrighted work, you may have a right to sue for relief under that Act.

Legal Notice

Information contained in this publication is provided for the sole purpose of designing with and using Microchip products. Information regarding device applications and the like is provided only for your convenience and may be superseded by updates. It is your responsibility to ensure that your application meets with your specifications.

THIS INFORMATION IS PROVIDED BY MICROCHIP "AS IS". MICROCHIP MAKES NO REPRESENTATIONS OR WARRANTIES OF ANY KIND WHETHER EXPRESS OR IMPLIED, WRITTEN OR ORAL, STATUTORY OR OTHERWISE, RELATED TO THE INFORMATION INCLUDING BUT NOT LIMITED TO ANY IMPLIED WARRANTIES OF NON-INFRINGEMENT, MERCHANTABILITY, AND FITNESS FOR A PARTICULAR PURPOSE OR WARRANTIES RELATED TO ITS CONDITION, QUALITY, OR PERFORMANCE.

IN NO EVENT WILL MICROCHIP BE LIABLE FOR ANY INDIRECT, SPECIAL, PUNITIVE, INCIDENTAL OR CONSEQUENTIAL LOSS, DAMAGE, COST OR EXPENSE OF ANY KIND WHATSOEVER RELATED TO THE INFORMATION OR ITS USE, HOWEVER CAUSED, EVEN IF MICROCHIP HAS BEEN ADVISED OF THE POSSIBILITY OR THE DAMAGES ARE FORESEEABLE. TO THE FULLEST EXTENT ALLOWED BY LAW, MICROCHIP'S TOTAL LIABILITY ON ALL CLAIMS IN ANY WAY RELATED TO THE INFORMATION OR ITS USE WILL NOT EXCEED THE AMOUNT OF FEES, IF ANY, THAT YOU HAVE PAID DIRECTLY TO MICROCHIP FOR THE INFORMATION. Use of Microchip devices in life support and/or safety applications is entirely at the buyer's risk, and the buyer agrees to defend, indemnify and hold harmless Microchip from any and all damages, claims, suits, or expenses resulting from such use. No licenses are conveyed, implicitly or otherwise, under any Microchip intellectual property rights unless otherwise stated.

Trademarks

The Microchip name and logo, the Microchip logo, Adaptec, AnyRate, AVR, AVR logo, AVR Freaks, BesTime, BitCloud, chipKIT, chipKIT logo, CryptoMemory, CryptoRF, dsPIC, FlashFlex, flexPWR, HELDO, IGLOO, JukeBlox, KeeLoq, Klear, LANCheck, LinkMD, maXStylus, maXTouch, MediaLB, megaAVR, Microsemi, Microsemi logo, MOST, MOST logo, MPLAB, OptoLyzer, PackeTime, PIC, picoPower, PICSTART, PIC32 logo, PolarFire, Prochip Designer, QTouch, SAM-BA, SenGenuity, SpyNIC, SST, SST Logo, SuperFlash, Symmetricom, SyncServer, Tachyon, TimeSource, tinyAVR, UNI/O, Vectron, and XMEGA are registered trademarks of Microchip Technology Incorporated in the U.S.A. and other countries.

AgileSwitch, APT, ClockWorks, The Embedded Control Solutions Company, EtherSynch, FlashTec, Hyper Speed Control, HyperLight Load, IntelliMOS, Libero, motorBench, mTouch, Powermite 3, Precision Edge, ProASIC, ProASIC Plus, ProASIC Plus logo, Quiet-Wire, SmartFusion, SyncWorld, Temux, TimeCesium, TimeHub, TimePictra, TimeProvider, WinPath, and ZL are registered trademarks of Microchip Technology Incorporated in the U.S.A.

Adjacent Key Suppression, AKS, Analog-for-the-Digital Age, Any Capacitor, AnyIn, AnyOut, Augmented Switching, BlueSky, BodyCom, CodeGuard, CryptoAuthentication, CryptoAutomotive, CryptoCompanion, CryptoController, dsPICDEM, dsPICDEM.net, Dynamic Average Matching, DAM, ECAN, Espresso T1S, EtherGREEN, IdealBridge, In-Circuit Serial Programming, ICSP, INICnet, Intelligent Paralleling, Inter-Chip Connectivity, JitterBlocker, maxCrypto, maxView, memBrain, Mindi, MiWi, MPASM, MPF, MPLAB Certified logo, MPLIB, MPLINK, MultiTRAK, NetDetach, Omniscient Code Generation, PICDEM, PICDEM.net, PICKit, PICtail, PowerSmart, PureSilicon, QMatrix, REAL ICE, Ripple Blocker, RTAX, RTG4, SAM-ICE, Serial Quad I/O, simpleMAP, SimpliPHY, SmartBuffer, SMART-I.S., storClad, SQL, SuperSwitcher, SuperSwitcher II, Switchtec, SynchroPHY, Total Endurance, TSHARC, USBCheck, VariSense, VectorBlox, VeriPHY, ViewSpan, WiperLock, XpressConnect, and ZENA are trademarks of Microchip Technology Incorporated in the U.S.A. and other countries.

SQTP is a service mark of Microchip Technology Incorporated in the U.S.A.

The Adaptec logo, Frequency on Demand, Silicon Storage Technology, and Symmcom are registered trademarks of Microchip Technology Inc. in other countries.

GestIC is a registered trademark of Microchip Technology Germany II GmbH & Co. KG, a subsidiary of Microchip Technology Inc., in other countries.

All other trademarks mentioned herein are property of their respective companies.

© 2020-2021, Microchip Technology Incorporated, Printed in the U.S.A., All Rights Reserved.

ISBN: 978-1-5224-8620-6

Quality Management System

For information regarding Microchip's Quality Management Systems, please visit www.microchip.com/quality.

Worldwide Sales and Service

AMERICAS	ASIA/PACIFIC	ASIA/PACIFIC	EUROPE
<p>Corporate Office 2355 West Chandler Blvd. Chandler, AZ 85224-6199 Tel: 480-792-7200 Tel: 480-792-7277 Technical Support: www.microchip.com/support Web Address: www.microchip.com</p> <p>Atlanta Duluth, GA Tel: 678-957-9614 Fax: 678-957-1455</p> <p>Austin, TX Tel: 512-257-3370</p> <p>Boston Westborough, MA Tel: 774-760-0087 Fax: 774-760-0088</p> <p>Chicago Itasca, IL Tel: 630-285-0071 Fax: 630-285-0075</p> <p>Dallas Addison, TX Tel: 972-818-7423 Fax: 972-818-2924</p> <p>Detroit Novi, MI Tel: 248-848-4000</p> <p>Houston, TX Tel: 281-894-5983</p> <p>Indianapolis Noblesville, IN Tel: 317-773-8323 Fax: 317-773-5453 Tel: 317-536-2380</p> <p>Los Angeles Mission Viejo, CA Tel: 949-462-9523 Fax: 949-462-9608 Tel: 951-273-7800</p> <p>Raleigh, NC Tel: 919-844-7510</p> <p>New York, NY Tel: 631-435-6000</p> <p>San Jose, CA Tel: 408-735-9110 Tel: 408-436-4270</p> <p>Canada - Toronto Tel: 905-695-1980 Fax: 905-695-2078</p>	<p>Australia - Sydney Tel: 61-2-9868-6733</p> <p>China - Beijing Tel: 86-10-8569-7000</p> <p>China - Chengdu Tel: 86-28-8665-5511</p> <p>China - Chongqing Tel: 86-23-8980-9588</p> <p>China - Dongguan Tel: 86-769-8702-9880</p> <p>China - Guangzhou Tel: 86-20-8755-8029</p> <p>China - Hangzhou Tel: 86-571-8792-8115</p> <p>China - Hong Kong SAR Tel: 852-2943-5100</p> <p>China - Nanjing Tel: 86-25-8473-2460</p> <p>China - Qingdao Tel: 86-532-8502-7355</p> <p>China - Shanghai Tel: 86-21-3326-8000</p> <p>China - Shenyang Tel: 86-24-2334-2829</p> <p>China - Shenzhen Tel: 86-755-8864-2200</p> <p>China - Suzhou Tel: 86-186-6233-1526</p> <p>China - Wuhan Tel: 86-27-5980-5300</p> <p>China - Xian Tel: 86-29-8833-7252</p> <p>China - Xiamen Tel: 86-592-2388138</p> <p>China - Zhuhai Tel: 86-756-3210040</p>	<p>India - Bangalore Tel: 91-80-3090-4444</p> <p>India - New Delhi Tel: 91-11-4160-8631</p> <p>India - Pune Tel: 91-20-4121-0141</p> <p>Japan - Osaka Tel: 81-6-6152-7160</p> <p>Japan - Tokyo Tel: 81-3-6880-3770</p> <p>Korea - Daegu Tel: 82-53-744-4301</p> <p>Korea - Seoul Tel: 82-2-554-7200</p> <p>Malaysia - Kuala Lumpur Tel: 60-3-7651-7906</p> <p>Malaysia - Penang Tel: 60-4-227-8870</p> <p>Philippines - Manila Tel: 63-2-634-9065</p> <p>Singapore Tel: 65-6334-8870</p> <p>Taiwan - Hsin Chu Tel: 886-3-577-8366</p> <p>Taiwan - Kaohsiung Tel: 886-7-213-7830</p> <p>Taiwan - Taipei Tel: 886-2-2508-8600</p> <p>Thailand - Bangkok Tel: 66-2-694-1351</p> <p>Vietnam - Ho Chi Minh Tel: 84-28-5448-2100</p>	<p>Austria - Wels Tel: 43-7242-2244-39 Fax: 43-7242-2244-393</p> <p>Denmark - Copenhagen Tel: 45-4485-5910 Fax: 45-4485-2829</p> <p>Finland - Espoo Tel: 358-9-4520-820</p> <p>France - Paris Tel: 33-1-69-53-63-20 Fax: 33-1-69-30-90-79</p> <p>Germany - Garching Tel: 49-8931-9700</p> <p>Germany - Haan Tel: 49-2129-3766400</p> <p>Germany - Heilbronn Tel: 49-7131-72400</p> <p>Germany - Karlsruhe Tel: 49-721-625370</p> <p>Germany - Munich Tel: 49-89-627-144-0 Fax: 49-89-627-144-44</p> <p>Germany - Rosenheim Tel: 49-8031-354-560</p> <p>Israel - Ra'anana Tel: 972-9-744-7705</p> <p>Italy - Milan Tel: 39-0331-742611 Fax: 39-0331-466781</p> <p>Italy - Padova Tel: 39-049-7625286</p> <p>Netherlands - Drunen Tel: 31-416-690399 Fax: 31-416-690340</p> <p>Norway - Trondheim Tel: 47-72884388</p> <p>Poland - Warsaw Tel: 48-22-3325737</p> <p>Romania - Bucharest Tel: 40-21-407-87-50</p> <p>Spain - Madrid Tel: 34-91-708-08-90 Fax: 34-91-708-08-91</p> <p>Sweden - Gothenberg Tel: 46-31-704-60-40</p> <p>Sweden - Stockholm Tel: 46-8-5090-4654</p> <p>UK - Wokingham Tel: 44-118-921-5800 Fax: 44-118-921-5820</p>