

## Introduction

This programming specification describes an SPI-based programming method for the PIC16F17576 family of microcontrollers. The [Programming Algorithms](#) section describes the programming commands, programming algorithms and electrical specifications used in that particular method. [Appendix B](#) contains individual part numbers, device identification, pinout and packaging information as well as Configuration Words.

---

 **Important:** To enter Low-Voltage Programming (LVP) mode, the Most Significant bit (MSb) of the Most Significant nibble must be shifted in first. This differs from entering the key sequence on some other device families.

---

# Table of Contents

Introduction.....	1
1. Overview.....	3
1.1. Programming Data Flow.....	3
1.2. Pin Utilization.....	3
1.3. Hardware Requirements.....	3
1.4. Write and/or Erase Selection.....	4
2. Memory Map.....	5
2.1. User ID Locations.....	5
2.2. Device/Revision ID.....	5
2.3. Device Information Area (DIA).....	5
2.4. Device Configuration Information (DCI).....	6
2.5. Configuration Words.....	7
2.6. Device ID .....	8
2.7. Revision ID .....	9
3. Programming Algorithms.....	10
3.1. Program/Verify Mode.....	10
3.2. Program/Verify Commands.....	12
3.3. Programming Algorithms.....	18
3.4. Code Protection.....	24
3.5. Hex File Usage.....	24
3.6. CRC Checksum Computation.....	25
4. Electrical Specifications.....	26
5. Appendix A: Revision History.....	28
6. Appendix B: Pinout Descriptions and Configuration Words.....	29
6.1. CONFIG1.....	30
6.2. CONFIG2.....	32
6.3. CONFIG3.....	34
6.4. CONFIG4.....	36
6.5. CONFIG5.....	38
Microchip Information.....	39
The Microchip Website.....	39
Product Change Notification Service.....	39
Customer Support.....	39
Microchip Devices Code Protection Feature.....	39
Legal Notice.....	39
Trademarks.....	40
Quality Management System.....	41
Worldwide Sales and Service.....	42

## 1. Overview

### 1.1 Programming Data Flow

Nonvolatile Memory (NVM) programmed data can be supplied by either the high-voltage In-Circuit Serial Programming™ (ICSP™) interface or the low-voltage ICSP interface. Data can be programmed into the Program Flash Memory (PFM), Data Flash Memory (EEPROM), dedicated User ID locations and the Configuration Words.

### 1.2 Pin Utilization

Five pins are needed for ICSP programming. The pins are listed in [Table 1-1](#). For pin locations and packaging information, refer to [Table 6-1](#).

**Table 1-1.** Pin Descriptions During Programming

Pin Name	During Programming		
	Function	Pin Type	Pin Description
ICSPCLK	ICSPCLK	I	Clock Input – Schmitt Trigger Input
ICSPDAT	ICSPDAT	I/O	Data Input/Output – Schmitt Trigger Input
$\overline{\text{MCLR}}/\text{V}_{\text{PP}}$	Program/Verify mode	I(1)	Program Mode Select
$\text{V}_{\text{DD}}$	$\text{V}_{\text{DD}}$	P	Power Supply
$\text{V}_{\text{SS}}$	$\text{V}_{\text{SS}}$	P	Ground

Legend: I = Input, O = Output, P = Power

**Note:**

- The programming high voltage is internally generated. To activate the Program/Verify mode, a high voltage needs to be applied to the  $\overline{\text{MCLR}}$  input. Since the  $\overline{\text{MCLR}}$  is used for a level source,  $\overline{\text{MCLR}}$  does not draw any significant current.

### 1.3 Hardware Requirements

#### 1.3.1 High-Voltage ICSP Programming

In High-Voltage ICSP mode, the device requires two programmable power supplies: One for  $\text{V}_{\text{DD}}$  and one for the  $\overline{\text{MCLR}}/\text{V}_{\text{PP}}$  pin.

#### 1.3.2 Low-Voltage ICSP Programming

In Low-Voltage ICSP mode, the device can be programmed using a single  $\text{V}_{\text{DD}}$  source in the device operating range. The  $\overline{\text{MCLR}}/\text{V}_{\text{PP}}$  pin does not have to be brought to the programming voltage, but can instead be left at the normal operating voltage.

##### 1.3.2.1 Single-Supply ICSP Programming

The device's LVP Configuration bit enables single-supply (low-voltage) ICSP programming. The LVP bit defaults to a '1' (enabled). The LVP bit may only be programmed to '0' by entering the High-Voltage ICSP mode, where the  $\overline{\text{MCLR}}/\text{V}_{\text{PP}}$  pin is raised to  $\text{V}_{\text{IHH}}$ . Once the LVP bit is programmed to a '0', only the High-Voltage ICSP mode is available and can be used to program the device.



**Important:**

- The High-Voltage ICSP mode is always available, regardless of the state of the LVP bit, by applying  $\text{V}_{\text{IHH}}$  to the  $\overline{\text{MCLR}}/\text{V}_{\text{PP}}$  pin.
- While in Low-Voltage ICSP mode,  $\overline{\text{MCLR}}$  is always enabled regardless of the MCLRE bit. Also, the  $\overline{\text{MCLR}}$  pin can no longer be used as a general purpose input.

## 1.4 Write and/or Erase Selection

Erasing or writing is selected according to the command used to begin operation (see [Table 3-1](#)). The terminologies used in this document, related to erasing/writing to the program memory, are defined in [Table 1-2](#).

**Table 1-2.** Programming Terms

Term	Definition
Programmed Cell	A memory cell at logic '0'
Erased Cell	A memory cell at logic '1'
Erase	Change memory cell from a '0' to a '1'
Write	Change memory cell from a '1' to a '0'
Program	Generic erase and/or write

### 1.4.1 Erasing Memory

Program Flash Memory (PFM) is erased by row or in bulk, while EEPROM and the Configuration Words can be erased by word or in bulk. 'Row' refers to the minimum number of words that can be programmed/erased and 'bulk' includes many subsets of the total memory space. The duration of the erase is always determined internally and is determined by the size of the memory. All Bulk ICSP Erase commands have minimum  $V_{DD}$  requirements, which are higher than the Row Erase and Write requirements.



**Important:** Bulk erasing is not supported in self-write operations.

### 1.4.2 Writing Memory

Program Flash Memory (PFM) is written one row at a time while EEPROM is written one word at a time. Multiple Load Data for NVM commands are used to fill the PFM's row data latches. The duration of the write is determined either internally or externally.

### 1.4.3 Multi-Word Programming Interface

PFM panels include a 32-word (one row) programming interface. The row to be programmed must first be erased with either a Bulk Erase or Row Erase command.

## 2. Memory Map

This section provides details on how the memory is organized for this device.

**Table 2-1.** Program Memory Map

Address	Device		
	PIC16F175x4	PIC16F175x5	PIC16F175x6
0000h to 0FFFh	Program Flash Memory (4 KW) <sup>(1)</sup>	Program Flash Memory (8 KW) <sup>(1)</sup>	Program Flash Memory (16 KW) <sup>(1)</sup>
1000h to 1FFFh	<b>Not Present</b> <sup>(2)</sup>		
2000h to 3FFFh		<b>Not Present</b> <sup>(2)</sup>	
4000h to 7FFFh			<b>Not Present</b> <sup>(2)</sup>
8000h to 8003h	User IDs (4 Words) <sup>(3)</sup>		
8004h	<b>Reserved</b>		
8005h	Revision ID (1 Word) <sup>(3)(4)(5)</sup>		
8006h	Device ID (1 Word) <sup>(3)(4)(5)</sup>		
8007h to 800Bh	Configuration Words <sup>(3)</sup>		
800Ch to 80FFh	<b>Reserved</b>		
8100h to 813Fh	Device Information Area (DIA) <sup>(3)(5)</sup>		
8140h to 81FFh	<b>Reserved</b>		
8200h to 82FFh	Device Configuration Information <sup>(3)(4)(5)</sup>		
8300h to EFFFh	<b>Reserved</b>		
F000h to F0FFh	EEPROM		
F100h to FFFFh	<b>Reserved</b>		

**Notes:**

- Storage Area Flash (SAF) is implemented as the last 128 words of Program Flash Memory, if enabled.
- The addresses do not roll over. The region is read as '0'. When accessing these areas using the NVMCON registers, reads and/or writes will set the NVMERR bit.
- Not code-protected.
- Hard-coded in silicon.
- This region cannot be written by the user, and is not affected by a Bulk Erase.

### 2.1 User ID Locations

A user may store identification information (User ID) in four locations. The User ID locations are mapped to 8000h - 8003h. Each location is 14 bits in length. Code protection has no effect on these memory locations. Each location may be read with or without code protection enabled.

### 2.2 Device/Revision ID

The 14-bit [Device ID](#) register is located at 8006h and the 14-bit [Revision ID](#) register is located at 8005h. These locations are read-only and cannot be erased or modified.

### 2.3 Device Information Area (DIA)

The Device Information Area (DIA) is a dedicated region in the Program Flash Memory. The data is mapped from address 8100h to 813Fh. These locations are read-only and cannot be erased or modified. The DIA contains the Microchip Unique Identifier words and the Fixed Voltage Reference (FVR) voltage readings in millivolts (mV). [Table 2-2](#) holds the DIA information for the PIC16F17576 family of microcontrollers.

**Table 2-2. Device Information Area**

Address Range	Name of Region	Standard Device Information
8100h-8108h	MUI0	Microchip Unique Identifier (9 Words)
	MUI1	
	MUI2	
	MUI3	
	MUI4	
	MUI5	
	MUI6	
	MUI7	
	MUI8	
8109h	MUI9	Reserved (1 Word)
810Ah-8111h	EUI0	Optional External Unique Identifier (8 Words)
	EUI1	
	EUI2	
	EUI3	
	EUI4	
	EUI5	
	EUI6	
	EUI7	
8112h	TSLR1 <sup>(1)</sup>	Gain = $\frac{0.1C \times 256}{count}$ (low-range setting)
8113h	TSLR2 <sup>(1)</sup>	Temperature indicator ADC reading at 90°C (low-range setting)
8114h	TSLR3 <sup>(1)</sup>	Offset (low-range setting)
8115h	TSHR1 <sup>(2)</sup>	Gain = $\frac{0.1C \times 256}{count}$ (high-range setting)
8116h	TSHR2 <sup>(2)</sup>	Temperature indicator ADC reading at 90°C (high-range setting)
8117h	TSHR3 <sup>(2)</sup>	Offset (high-range setting)
8118h	FVRA1X	ADC FVR1 Output voltage for 1x setting (in mV)
8119h	FVRA2X	ADC FVR1 Output Voltage for 2x setting (in mV)
811Ah	FVRA4X	ADC FVR1 Output Voltage for 4x setting (in mV)
811Bh	FVRC1X	Comparator FVR2 Output Voltage for 1x setting (in mV)
811Ch	FVRC2X	Comparator FVR2 Output Voltage for 2x setting (in mV)
811Dh	FVRC4X	Comparator FVR2 Output Voltage for 4x setting (in mV)
811Eh-811Fh	Reserved	Reserved (2 Words)
<b>Notes:</b>		
1. TSLR: Address 8112h - 8114h store the measurements for the low-range setting of the temperature sensor at $V_{DD} = 3V$ , $V_{REF+} = 2.048V$ from FVR1.		
2. TSHR: Address 8115h - 8117h store the measurements for the high-range setting of the temperature sensor at $V_{DD} = 3V$ , $V_{REF+} = 2.048V$ from FVR1.		

## 2.4 Device Configuration Information (DCI)

The Device Configuration Information (DCI) is a dedicated region in the memory that holds information about the device, which is useful for programming and bootloader applications. The data stored in this region is read-only and cannot be modified/erased. Refer to [Table 2-3](#) for the complete DCI table addresses and description.

**Table 2-3.** Device Configuration Information

Address	Name	Description	Value			Units
			PIC16F175x4	PIC16F175x5	PIC16F175x6	
8200h	ERSIZ	Erase Row Size	32			Words
8201h	WLSIZ	Number of write latches per row	32			Words
8202h	URSIZ	Number of user erasable rows	128	256	512	Rows
8203h	EESIZ	Data EEPROM memory size	128		256	Bytes
8204h	PCNT	Pin Count	14/20/28/40			Pins

## 2.5 Configuration Words

The devices have five Configuration Words, starting at address 8007h. The Configuration bits can enable or disable specific features, placing these controls outside the normal software process, while they establish configured values prior to the execution of any software.

In terms of programming, consider these important Configuration bits:

### 1. LVP: Low-Voltage Programming Enable bit

- 1 = ON: Low-Voltage Programming is enabled.  $\overline{\text{MCLR}}/\text{V}_{\text{PP}}$  pin function is  $\overline{\text{MCLR}}$ . The MCLRE Configuration bit is ignored.
- 0 = OFF: High voltage on  $\overline{\text{MCLR}}/\text{V}_{\text{PP}}$  must be used for programming.

 **Important:** The LVP bit cannot be written (to '0') while operating from the LVP programming interface. The purpose of this rule is to prevent the user from dropping out of LVP mode while programming from LVP mode, or accidentally eliminating LVP mode from the Configuration state. For more information, see the [Low-Voltage Programming \(LVP\) Mode](#) section.

### 2. MCLRE: Master Clear ( $\overline{\text{MCLR}}$ ) Enable bit

- If LVP = 1: RA3 pin function is  $\overline{\text{MCLR}}$
- If LVP = 0
  - 1 =  $\overline{\text{MCLR}}$  pin is  $\overline{\text{MCLR}}$
  - 0 =  $\overline{\text{MCLR}}$  pin function is a port-defined function

### 3. CP: User NVM Program Memory Code Protection bit

- 1 = OFF: User Program Flash Memory code protection is disabled
- 0 = ON: User Program Flash Memory code protection is enabled

### 4. CPD: User Data EEPROM Code Protection bit

- 1 = OFF: Data EEPROM code protection is disabled
- 0 = ON: Data EEPROM code protection is enabled

For more information on code protection, see the [Code Protection](#) section.

## 2.6 Device ID

**Name:** DEVICEID  
**Offset:** 8006h

Device ID Register

Bit	15	14	13	12	11	10	9	8
			Reserved	Reserved	DEV[11:8]			
Access			R	R	R	R	R	R
Reset			1	1	q	q	q	q
Bit	7	6	5	4	3	2	1	0
	DEV[7:0]							
Access	R	R	R	R	R	R	R	R
Reset	q	q	q	q	q	q	q	q

**Bit 13 – Reserved** Reserved - Read as '1'

**Bit 12 – Reserved** Reserved - Read as '1'

**Bits 11:0 – DEV[11:0]** Device ID

Device	Device ID
PIC16F17524	3115h
PIC16F17525	3119h
PIC16F17526	311Dh
PIC16F17544	3116h
PIC16F17545	311Ah
PIC16F17546	311Eh
PIC16F17554	3117h
PIC16F17555	311Bh
PIC16F17556	311Fh
PIC16F17574	3118h
PIC16F17575	311Ch
PIC16F17576	3120h

## 2.7 Revision ID

**Name:** REVISIONID  
**Offset:** 8005h

Revision ID Register

Bit	15	14	13	12	11	10	9	8
			Reserved	Reserved	MJRREV[5:2]			
Access			R	R	R	R	R	R
Reset			1	0	q	q	q	q
Bit	7	6	5	4	3	2	1	0
	MJRREV[1:0]		MNRREV[5:0]					
Access	R	R	R	R	R	R	R	R
Reset	q	q	q	q	q	q	q	q

**Bit 13 – Reserved** Reserved - Read as '1'

**Bit 12 – Reserved** Reserved - Read as '0'

**Bits 11:6 – MJRREV[5:0]** Major Revision ID

These bits are used to identify a major revision (A0, B0, C0, etc.).

**Bits 5:0 – MNRREV[5:0]** Minor Revision ID

These bits are used to identify a minor revision.

## 3. Programming Algorithms

### 3.1 Program/Verify Mode

In Program/Verify mode, the program memory and the configuration memory can be accessed and programmed in serial fashion. ICSPDAT and ICSPCLK are used for the data and the clock, respectively. All commands and data words are transmitted MSb first. Data changes on the rising edge of the ICSPCLK and is latched on the falling edge. In Program/Verify mode, both the ICSPDAT and ICSPCLK pins are Schmitt Trigger inputs. The sequence that enters the device into Program/Verify mode places all other logic into the Reset state; all I/Os are automatically configured as high-impedance inputs and the Program Counter (PC) is cleared.

#### 3.1.1 High-Voltage Program/Verify Mode Entry and Exit

There are two different modes of entering Program/Verify mode via high voltage:

- $V_{PP}$ -First Entry mode
- $V_{DD}$ -First Entry mode

##### 3.1.1.1 $V_{PP}$ -First Entry Mode

To enter Program/Verify mode via the  $V_{PP}$ -First Entry mode, the following sequence must be followed:

1. Hold ICSPCLK and ICSPDAT low.
2. Raise the voltage on  $\overline{MCLR}$  from 0V to  $V_{IHH}$ .
3. Raise the voltage on  $V_{DD}$  from 0V to the desired operating voltage.

The  $V_{PP}$ -First Entry mode prevents the device from executing code prior to entering the Program/Verify mode. For example, when the Configuration Byte has already been programmed to have  $\overline{MCLR}$  disabled ( $MCLRE = 0$ ), the Power-up Timer disabled ( $PWRT = 0$ ) and the internal oscillator selected, the device will execute the code immediately.  $V_{PP}$ -First Entry mode is strongly recommended as it prevents the user code from executing (refer to the Mode diagram in [Figure 3-1](#) for more information).

**Figure 3-1.** Programming Entry and Exit Modes –  $V_{PP}$ -First and Last

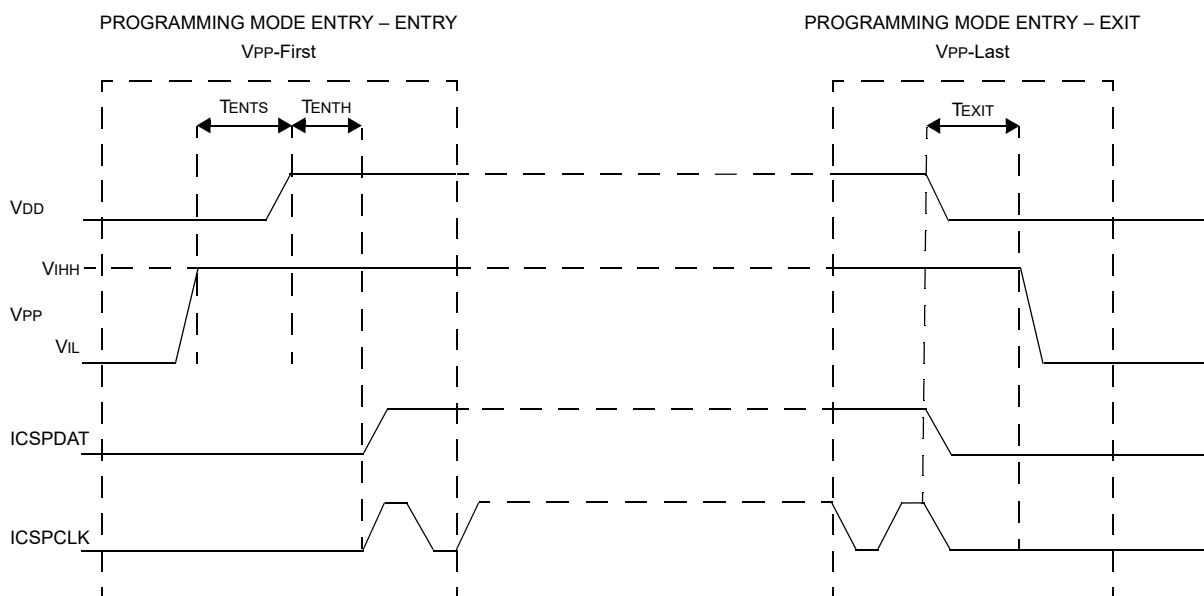

### 3.1.1.2 V<sub>DD</sub>-First Entry Mode

To enter the Program/Verify mode via the V<sub>DD</sub>-First Entry mode, the following sequence must be followed:

1. Hold ICSPCLK and ICSPDAT low.
2. Raise the voltage on V<sub>DD</sub> from 0V to the desired operating voltage.
3. Raise the voltage on  $\overline{\text{MCLR}}$  from V<sub>DD</sub> or below to V<sub>IHH</sub>.

The V<sub>DD</sub>-First Entry mode is useful for programming the device when the V<sub>DD</sub> is already applied. It is not necessary to disconnect V<sub>DD</sub> to enter the Program/Verify mode (refer to the Mode diagram in [Figure 3-2](#) for more information).

**Figure 3-2.** Programming Entry and Exit Modes – V<sub>DD</sub>-First and Last

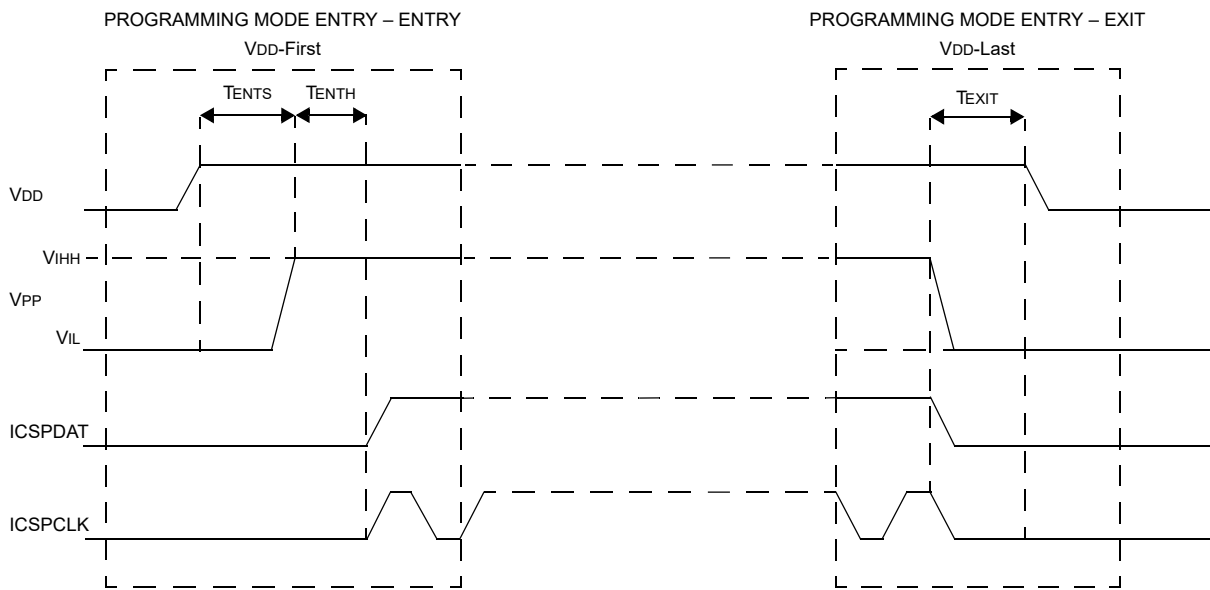

### 3.1.1.3 Program/Verify Mode Exit

To exit the Program/Verify mode, lower  $\overline{\text{MCLR}}$  from V<sub>IHH</sub> to V<sub>VIL</sub>. The V<sub>PP</sub>-First Entry mode will use the V<sub>PP</sub>-Last Exit mode (see [Figure 3-1](#)). The V<sub>DD</sub>-First Entry mode will use the V<sub>DD</sub>-Last Exit mode (see [Figure 3-2](#)).

### 3.1.2 Low-Voltage Programming (LVP) Mode

The Low-Voltage Programming mode allows the devices to be programmed using V<sub>DD</sub> only, without high voltage. When the LVP bit in the Configuration Word 4 register is set to '1', the Low-Voltage ICSP Programming entry is enabled. To disable the Low-Voltage ICSP mode, the LVP bit must be programmed to '0'. This can only be done while in the High-Voltage Entry mode.

Entry into the Low-Voltage ICSP Program/Verify mode requires the following steps:

1.  $\overline{\text{MCLR}}$  is brought to V<sub>VIL</sub>.
2. A 32-bit key sequence is presented on ICSPDAT and clocked by ICSPCLK. The Least Significant bit (LSb) of the pattern is a 'don't care x'. The Program/Verify mode entry pattern detect hardware verifies only the first 31 bits of the sequence and the last clock is required before the pattern detect goes active.

The key sequence is a specific 32-bit pattern, '32' h4d434850' (more easily remembered as MCHP in ASCII). The device will enter Program/Verify mode only if the sequence is valid. The MSb of the Most Significant Byte (MSB) must be shifted in first. Once the key sequence is complete,  $\overline{\text{MCLR}}$  must be

held at  $V_{IL}$  for as long as Program/Verify mode is to be maintained. For Low-Voltage Programming timing, see [Figure 3-3](#) and [Figure 3-4](#).

**Figure 3-3.** LVP Entry (Powered)

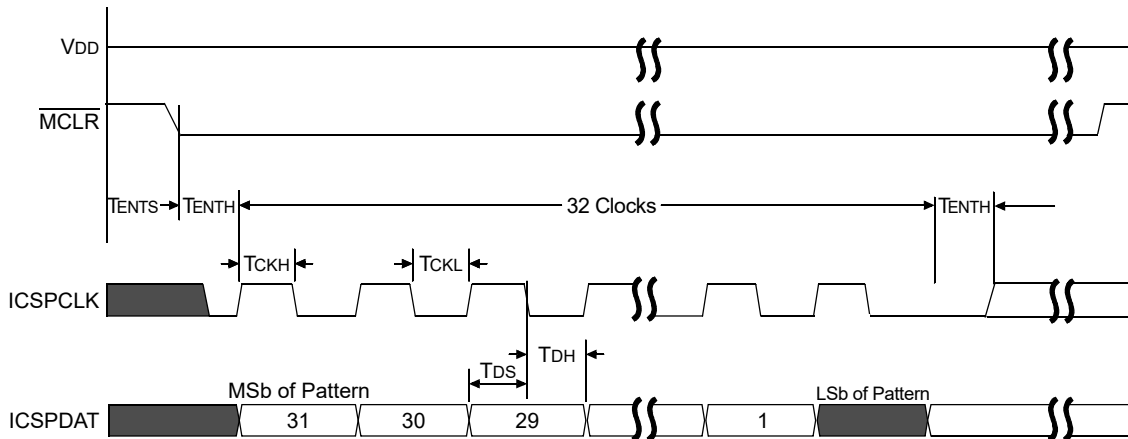

**Figure 3-4.** LVP Entry (Powering Up)

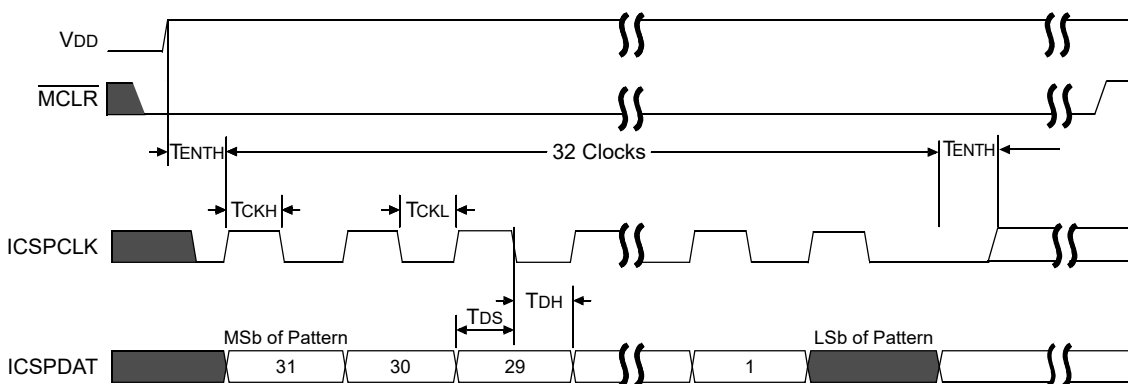

Exiting the Program/Verify mode is done by raising  $\overline{\text{MCLR}}$  from below  $V_{IL}$  to  $V_{IH}$  level (or higher, up to VDD).



**Important:**

To enter LVP mode, the MSb of the Most Significant nibble must be shifted in first. This differs from entering the key sequence on some other device families.

### 3.2 Program/Verify Commands

Once a device has entered ICSP Program/Verify mode (using either high-voltage or LVP entry), the programming host device may issue commands to the microcontroller, each eight bits in length. The commands are summarized in [Table 3-1](#) and are used to erase or program the device based on the location of the Program Counter (PC).

Some 8-bit commands also have an associated data payload (such as Load PC Address and Read Data from NVM).

If the host device issues an 8-bit command byte that has an associated data payload, the host device is responsible for sending an additional 24 clock pulses (e.g., three 8-bit bytes) to send or receive the payload data associated with the command.

The payload field size is compatible with many 8-bit SPI-based systems. Within each 24-bit payload field, the first bit transmitted is always a Start bit, followed by a variable number of Pad bits, followed by the useful data payload bits and ending with one Stop bit. The useful data payload bits are always transmitted MSb first.

When the programming device issues a command that involves a host to the microcontroller payload (e.g., Load PC Address), the Start, Stop and Pad bits must all be driven by the programmer, as defined by the data column in Table 3-1. When the programming host device issues a command that involves the microcontroller to host payload data (e.g., Read Data from NVM), the Start, Stop and Pad bits must be treated as 'don't care' bits and the values may be ignored by the host.

When the programming host device issues an 8-bit command byte to the microcontroller, the host must wait a specified minimum amount of delay (which is command-specific) prior to sending any additional clock pulses (associated with either a 24-bit data payload field or the next command byte).

**Table 3-1.** ICSP™ Command Set Summary

Command Name	Command Value		Payload Expected	Delay after Command	Data/Note
	Binary (MSb ... Lsb)	Hex			
Load PC Address	1000 0000	80	Yes	T <sub>DLY</sub>	Payload Value = PC
Bulk Erase Program Memory	0001 1000	18	Yes	T <sub>ERAB</sub>	The payload is used to identify the regions that need to be bulk erased.
Row Erase Program Memory	1111 0000	F0	No	T <sub>ERAS</sub>	The row addressed by the MSBs of the PC is erased; LSbs are ignored.
Load Data for NVM	0000 00J0	00/02	Yes – Data In	T <sub>DLY</sub>	Data is loaded to the data latch addressed by the LSbs of the PC; MSbs are ignored. J = 0: PC is unchanged J = 1: PC = PC + 1 after writing
Read Data from NVM	1111 11J0	FC/FE	Yes – Data Out	T <sub>DLY</sub>	Data output '0' if code-protect is enabled. J = 0: PC is unchanged J = 1: PC = PC + 1 after reading
Increment Address	1111 1000	F8	No	T <sub>DLY</sub>	PC = PC + 1
Begin Internally Timed Programming	1110 0000	E0	No	T <sub>PINT</sub>	Commits latched data to NVM (self-timed).
Begin Externally Timed Programming	1100 0000	C0	No	T <sub>PEXT</sub>	Commits latched data to NVM (externally timed). After T <sub>PEXT</sub> , the End Externally Timed Programming command must be used.
End Externally Timed Programming	1000 0010	82	No	T <sub>DIS</sub>	Must be issued within required time delay (T <sub>PEXT</sub> ) after the Begin Externally Timed Programming command.



1. Bit 0: Data EEPROM (if available)
2. Bit 1: Flash memory
3. Bit 2: User ID memory
4. Bit 3: Configuration memory

**➔ Important:** If the device is code-protected and a Bulk Erase command for the Configuration memory is issued, all other regions are also bulk erased.

After receiving the Bulk Erase command, the erase will complete after the time interval,  $T_{ERAB}$ . See Figure 3-7 for the Bulk Erase command structure.

Figure 3-7. Bulk Erase Memory

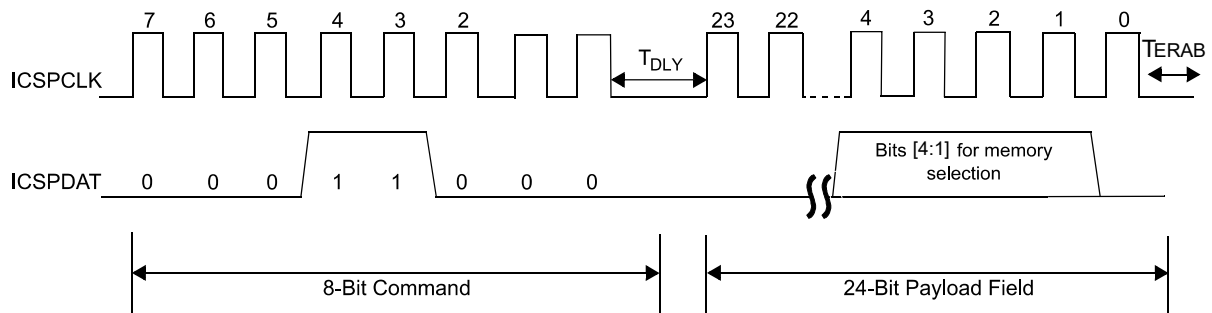

### 3.2.3 Row Erase Program Memory

The Row Erase Program Memory command will erase an individual row. If the program memory is code-protected, the Row Erase Program Memory command will be ignored. When the address is 8000h-8004h, the Row Erase Program Memory command will only erase the User ID locations regardless of the setting of the  $\overline{CP}$  Configuration bit. When write and erase operations are done on a row basis, the row size (number of 14-bit words) for erase operation is 32 and the row size (number of 14-bit latches) for the write operation is 32.

The Flash memory row defined by the current PC will be erased. The user must wait  $T_{ERAR}$  for erasing to complete (see Figure 3-8).

Figure 3-8. Row Erase Program Memory

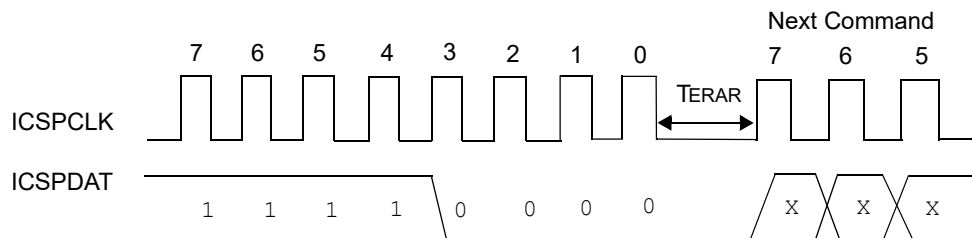

### 3.2.4 Load Data for NVM

The Load Data for the NVM command is used to load one programming data latch (e.g., one 14-bit instruction word for program memory/configuration memory/User ID memory). The Load Data for the NVM command can be used to load data for Program Flash Memory (see Figure 3-9). The word writes into the program memory after the Begin Internally Timed Programming or Begin Externally Timed Programming commands write the entire row of data latches, not just one word. The lower five bits of the address are considered while the other bits are ignored. Depending on the value of bit 1 of the command, the Program Counter (PC) may or may not be incremented (see Table 3-1).

**Figure 3-9. Load Data for NVM**

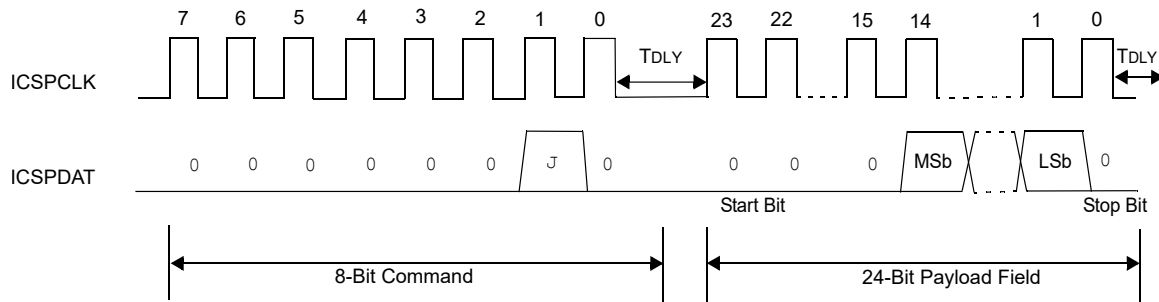

### 3.2.5 Read Data from NVM

The Read Data from the NVM command will transmit data bits out of the current PC address. The ICSPDAT pin will go into Output mode on the first falling edge of ICSPCLK, and it will revert to Input mode (high-impedance) after the 24th falling edge of the clock. The Start and Stop bits are only one half of a bit time wide and must be ignored by the host programmer device (since the latched value may be indeterminate). Additionally, the host programmer device must only consider the MSb to LSb payload bits as valid and must ignore the values of the Pad bits. If the program memory is code-protected ( $\overline{CP} = 0$ ), the data will be read as zeros (see Figure 3-10). Depending on the value of bit '1' of the command, the PC may or may not be incremented (see Table 3-1).

**Figure 3-10. Read Data from NVM**

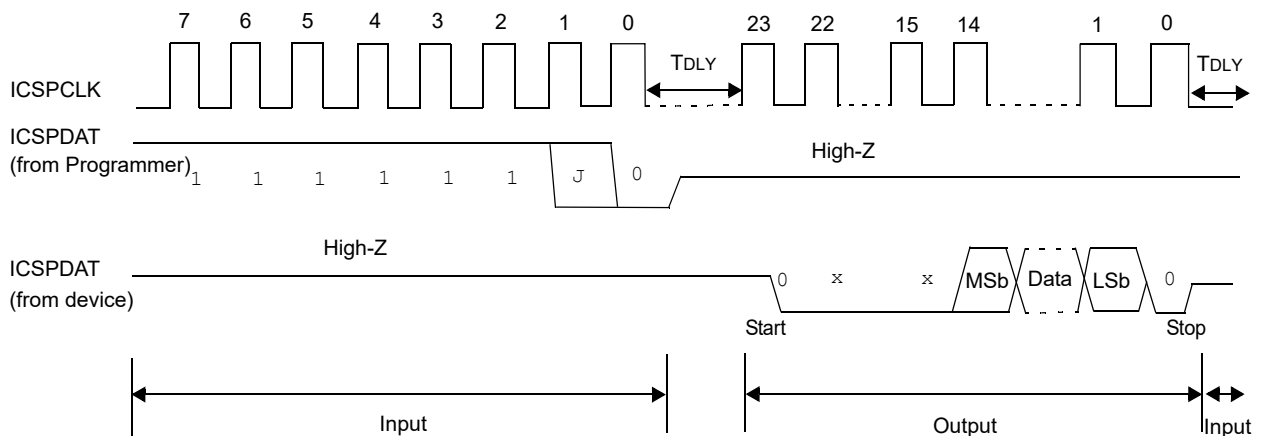

### 3.2.6 Increment Address

The PC is incremented by one when this command is received. It is not possible to decrement the address. To reset this counter, the user must use the Load PC Address command. This command performs the same action as the J bit in the Load/Read commands (see Figure 3-11 for command increments).

Figure 3-11. Increment Address

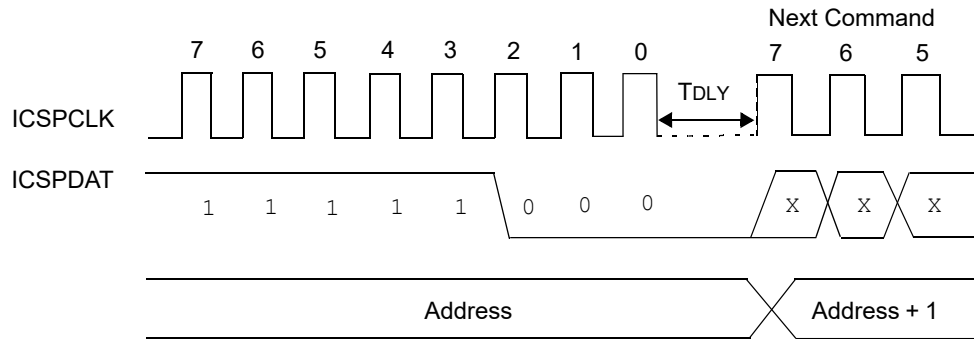

### 3.2.7 Begin Internally Timed Programming

The write programming latches must already have been loaded using the Load Data for NVM command, prior to issuing the Begin Internally Timed Programming command. Programming of the addressed memory row will begin after this command is received. The lower LSbs of the address are ignored. An internal timing mechanism executes the write. The user must allow for the Erase/Write cycle time,  $T_{PINT}$ , for the programming to complete, prior to issuing the next command (see Figure 3-12).

After the programming cycle is complete, all the data latches are reset to '1'.

Figure 3-12. Begin Internally Timed Programming

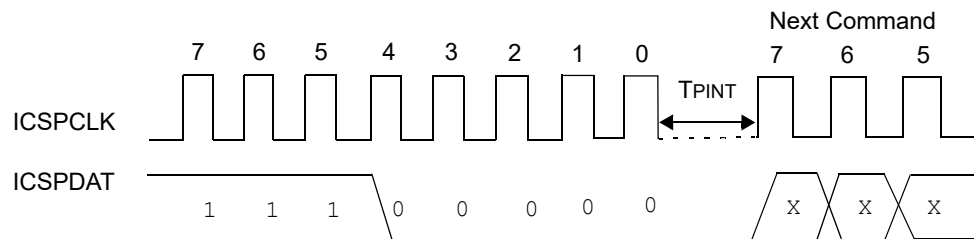

### 3.2.8 Begin Externally Timed Programming

The data to be programmed must be previously loaded by the Load Data for NVM command before every Begin Externally Timed Programming command. To complete the programming, the End Externally Timed Programming command must be sent in the specified time window defined by  $T_{PEXT}$  (see Figure 3-13). The lower LSbs of the address are ignored.

Externally timed writes are not supported for the Configuration Words. Any externally timed write to the Configuration Words will have no effect on the targeted word.

Figure 3-13. Begin Externally Timed Programming

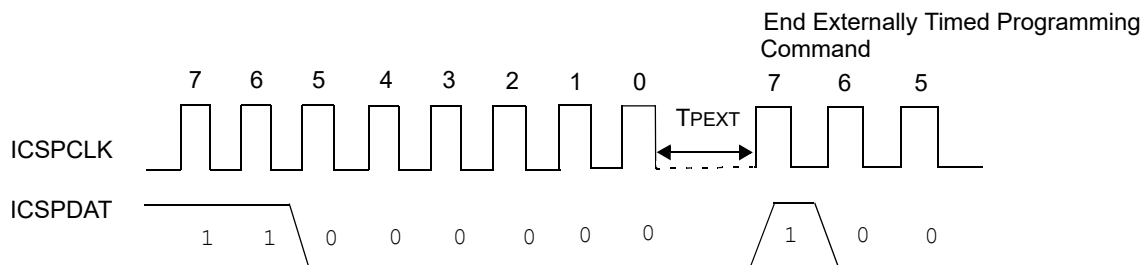

### 3.2.9 End Externally Timed Programming

This command is required to terminate the programming sequence after a Begin Externally Timed Programming command is given. If no programming command is in progress or if the programming cycle is internally timed, this command will execute as a No Operation (NOP) (see Figure 3-14).

Figure 3-14. End Externally Timed Programming

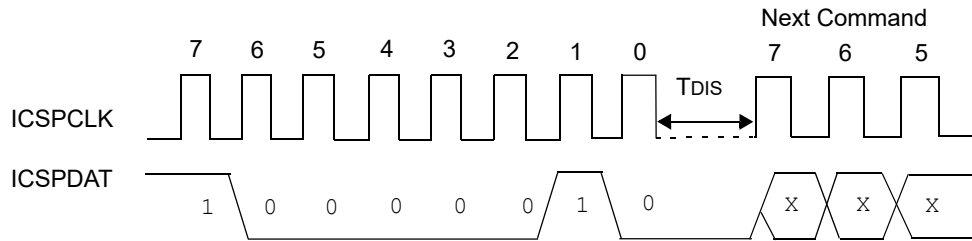

## 3.3 Programming Algorithms

The device uses internal latches to temporarily store the 14-bit words used for programming. The data latches allow the user to program a full row with a single Begin Internally Timed Programming or Begin Externally Timed Programming command. The Load Data for NVM command is used to load a single data latch. The data latch will hold the data until the Begin Internally Timed Programming or Begin Externally Timed Programming command is given.

The data latches are aligned with the LSBs of the address. The address at the time the Begin Internally Timed Programming or Begin Externally Timed Programming command is given will determine which memory row is written. Writes cannot cross a physical row boundary. For example, attempting to write from address 0002h-0021h in a 32-latch device will result in data being written to 0020h-003Fh.

If more than the maximum number of latches are written without a Begin Internally Timed Programming or Begin Externally Timed Programming command, the data in the data latches will be overwritten. The following flowcharts show the recommended flowcharts for programming.

**➔ Important:** The Program Flash Memory region is programmed one row (32 words) at a time (Figure 3-18), while the Configuration Words and Data EEPROM are programmed one word at a time (Figure 3-17). The value of the PC at the time of issuing the Begin Internally Timed Programming or Begin Externally Timed Programming command determines what row (of Program Flash Memory), or what word (of Configuration Word/EEPROM) will get programmed.

Figure 3-15. Device Program/Verify Flowchart

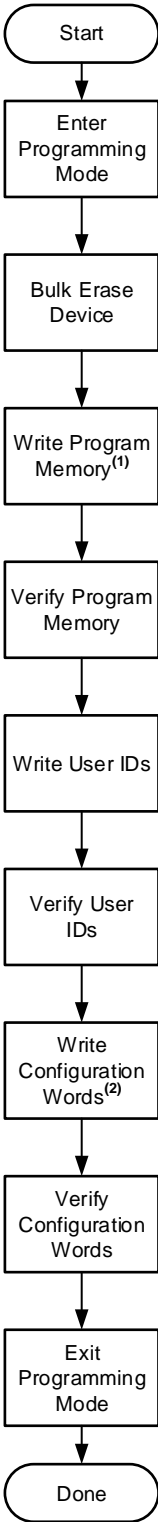

**Notes:**

1. See the [Load PC Address](#) section.
2. See the [Row Erase Program Memory](#) section.

**Figure 3-16.** Program Memory Flowchart

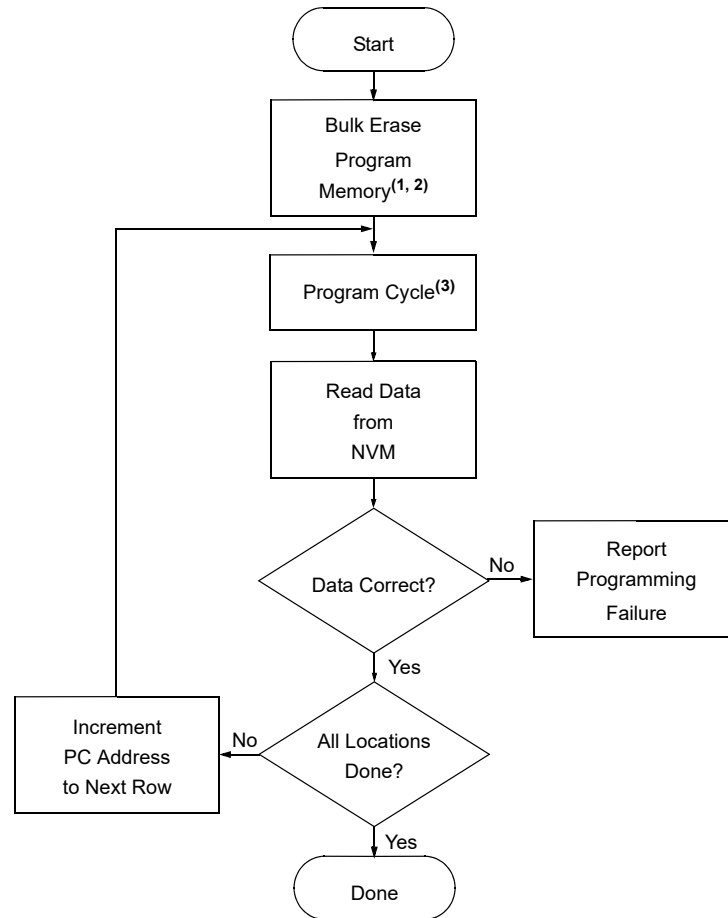

**Notes:**

1. This step is optional if the device has already been erased or has not been previously programmed.
2. If the device is code-protected or must be completely erased, then Bulk Erase the device per [Figure 3-20](#).
3. See the [Bulk Erase](#) section.

Figure 3-17. One-Word Program Cycle

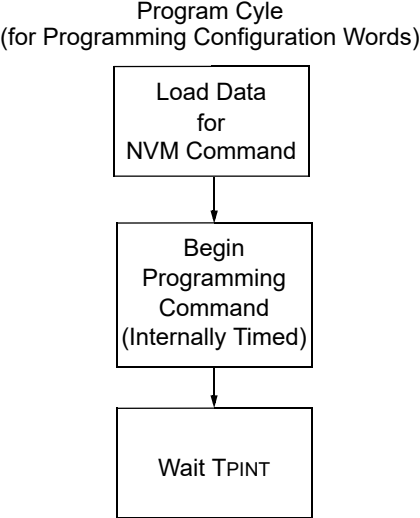

Figure 3-18. Multiple-Word Program Cycle

**Program Cycle  
(for Writing to Program Flash Memory)**

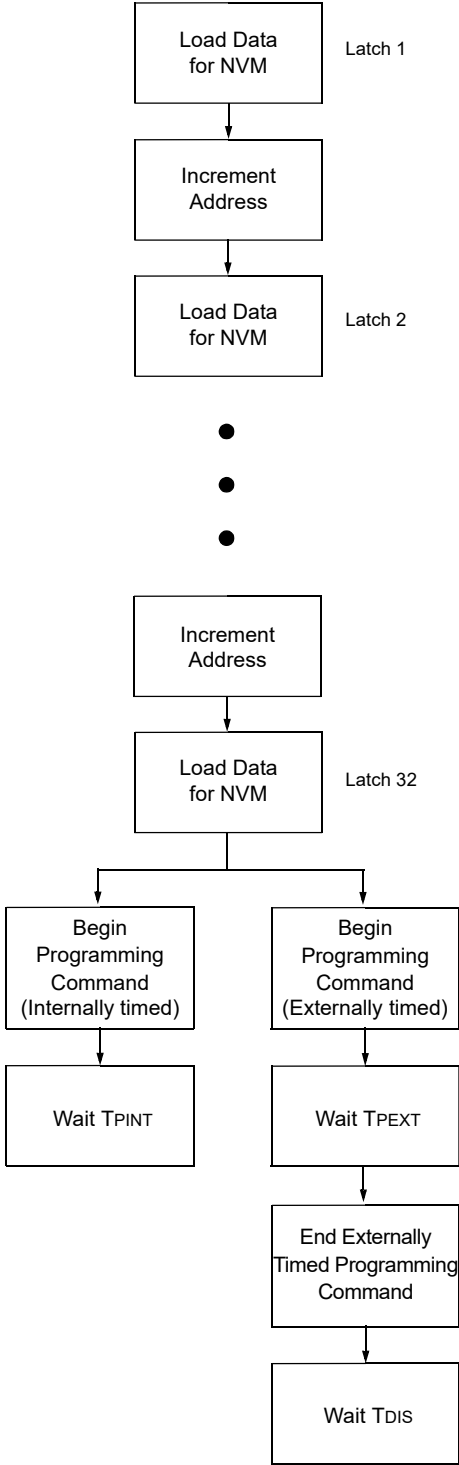
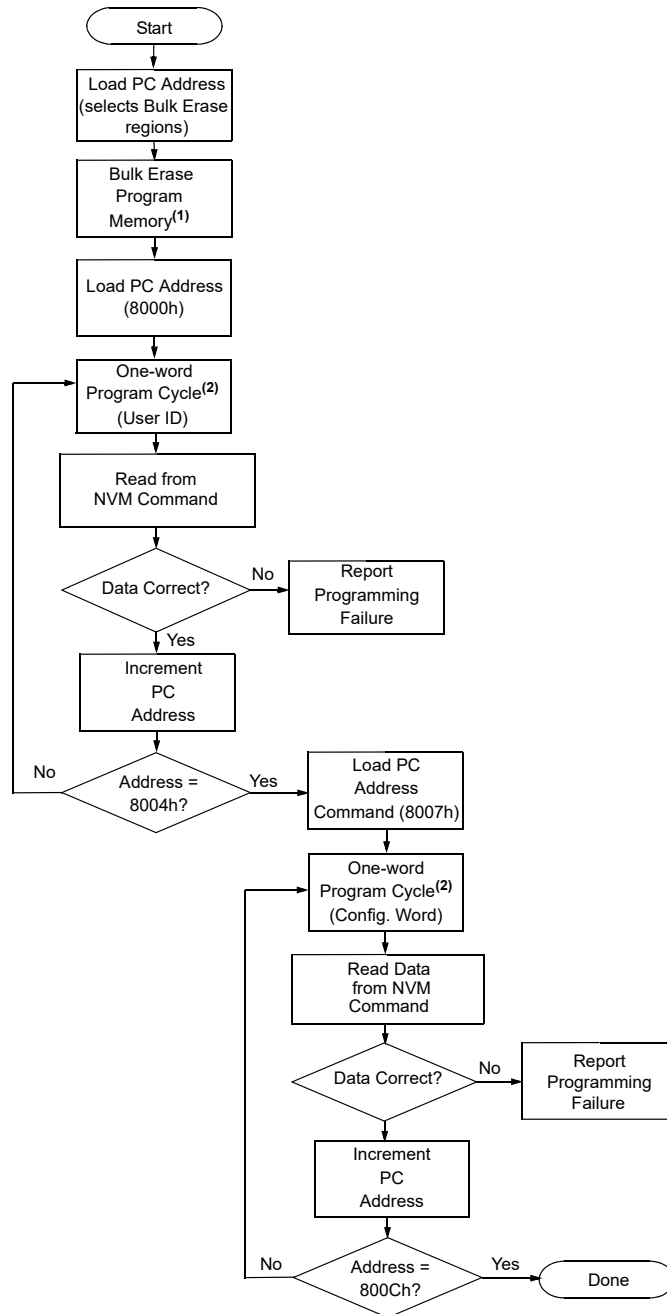

Figure 3-19. Configuration Memory Program Flowchart



**Notes:**

1. This step is optional if the device is erased or not previously programmed.
2. See the [Begin Internally Timed Programming](#) section.

Figure 3-20. Bulk Erase Flowchart

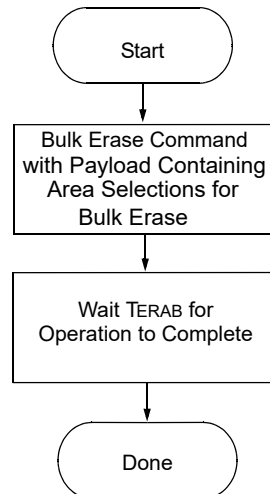

### 3.4 Code Protection

Program memory code protection is controlled using the  $\overline{CP}$  bit, while data EEPROM memory code protection is controlled using the  $\overline{CPD}$  bit. When code protection is enabled, all program memory and Data EEPROM locations read as '0'. Further programming is disabled for the program memory and Data EEPROM until a Bulk Erase operation is performed on the configuration memory region. Program memory and Data EEPROM can still be programmed and read during program execution.

The User ID locations and Configuration Bytes can be programmed and read out regardless of the code protection settings.

The only way to disable code protection is to use the Bulk Erase Program Memory command with bit 4 of the payload set to '1'. This will disable code protection and erase all memory locations.

### 3.5 Hex File Usage

In the hex file, there are two bytes per program word stored in the Intel® INHX32 hex format. Data is stored LSB first and MSB second. Since there are two bytes per word, the addresses in the hex file are two-times the address in the program memory. For example, if the Configuration Word 1 is stored at 8007h, in the hex file this will be referenced as 1000Eh-1000Fh.

#### 3.5.1 Configuration Words

To allow portability of code, it is strongly recommended that the programmer be able to read the Configuration Words and User ID locations from the hex file. If the Configuration Words information is not present in the hex file, a simple warning message may be issued. Similarly, while saving a hex file, the Configuration Words and User ID information need to be included.



**Important:** Microchip Technology Inc. considers this feature to be an important benefit to the end customer.

#### 3.5.2 Device ID

If a Device ID is present in the hex file at 1000Ch-1000Dh (8006h on the part), the programmer must verify the Device ID against the value read from the part. On a mismatch condition, the programmer must generate a warning message.

### 3.6 CRC Checksum Computation

Unlike older PIC<sup>®</sup> devices, the Microchip toolchain runs a 32-bit CRC calculation on the entire hex file to calculate its checksum. The checksum uses the standard CRC-32 algorithm with the polynomial 0x4C11DB7 ( $x^{32} + x^{26} + x^{23} + x^{22} + x^{16} + x^{12} + x^{11} + x^{10} + x^8 + x^7 + x^5 + x^4 + x^2 + x + 1$ ).

## 4. Electrical Specifications

Refer to the device-specific data sheet for the absolute maximum ratings.

**Table 4-1. AC/DC Characteristic Timing Requirements for Program/Verify Mode**

AC/DC Characteristics		Standard Operating Conditions Production tested at +25°C				
Sym.	Characteristics	Min.	Typ.	Max.	Units	Conditions/Comments
<b>Programming Supply Voltages and Currents</b>						
V <sub>DD</sub>	Supply Voltage (V <sub>DDMIN</sub> , V <sub>DDMAX</sub> )	1.8	—	5.5	V	(Note 1)
V <sub>PEW</sub>	Read/Write and Row Erase Operations	V <sub>DDMIN</sub>	—	V <sub>DDMAX</sub>	V	
V <sub>BE</sub>	Bulk Erase Operations	V <sub>BORMAX</sub>	—	V <sub>DDMAX</sub>	V	(Note 2)
I <sub>DDI</sub>	Current on V <sub>DD</sub> , Idle	—	—	1	mA	
I <sub>DDP</sub>	Current on V <sub>DD</sub> , Programming	—	—	10	mA	
I <sub>PP</sub>	<b>V<sub>PP</sub></b>					
	Current on MCLR/V <sub>PP</sub>	—	—	600	μA	
V <sub>IHH</sub>	High Voltage on MCLR/V <sub>PP</sub> for Program/Verify Mode Entry	7.9	—	9	V	
T <sub>VHHR</sub>	MCLR Rise Time (V <sub>IL</sub> to V <sub>IHH</sub> ) for Program/Verify Mode Entry	—	—	1	μs	
<b>I/O Pins</b>						
V <sub>IH</sub>	(ICSPCLK, ICSPDAT, MCLR/V <sub>PP</sub> ) Input High Level	0.8 V <sub>DD</sub>	—	V <sub>DD</sub>	V	
V <sub>IL</sub>	(ICSPCLK, ICSPDAT, MCLR/V <sub>PP</sub> ) Input Low Level	V <sub>SS</sub>	—	0.2 V <sub>DD</sub>	V	
V <sub>OH</sub>	ICSPDAT Output High Level	V <sub>DD</sub> -0.7	—	—	V	I <sub>OH</sub> = 3 mA, V <sub>DD</sub> = 3.0V
V <sub>OL</sub>	ICSPDAT Output Low Level	—	—	V <sub>SS</sub> + 0.6	V	I <sub>OL</sub> = 6 mA, V <sub>DD</sub> = 3.0V
<b>Programming Mode Entry and Exit</b>						
T <sub>ENTS</sub>	Programming Mode Entry Setup Time: ICSPCLK, ICSPDAT Setup Time before V <sub>DD</sub> or MCLR↑	100	—	—	ns	
T <sub>ENTH</sub>	Programming Mode Entry Hold Time: ICSPCLK, ICSPDAT Hold Time before V <sub>DD</sub> or MCLR↑	250	—	—	μs	
<b>Serial Program/Verify</b>						
T <sub>CKL</sub>	Clock Low Pulse Width	100	—	—	ns	
T <sub>CKH</sub>	Clock High Pulse Width	100	—	—	ns	
T <sub>DS</sub>	Data in Setup Time before Clock↓	100	—	—	ns	
T <sub>DH</sub>	Data in Hold Time after Clock↓	100	—	—	ns	
T <sub>CO</sub>	Clock↑ to Data Out Valid (during a Read Data from NVM command)	0	—	80	ns	
T <sub>LZD</sub>	Clock↓ to Data Low-Impedance (during a Read Data from NVM command)	0	—	80	ns	
T <sub>HZD</sub>	Clock↓ to Data High-Impedance (during a Read Data from NVM command)	0	—	80	ns	
T <sub>DLY</sub>	Data Input not Driven to Next Clock Input (delay required between command/data or command/command)	1	—	—	μs	
T <sub>ERAB</sub>	Bulk Erase Cycle Time	—	—	40	ms	Program, Config, Data Flash Memory (EEPROM) and ID

.....continued

AC/DC Characteristics		Standard Operating Conditions Production tested at +25°C				
Sym.	Characteristics	Min.	Typ.	Max.	Units	Conditions/ Comments
T <sub>ERAR</sub>	Row Erase Cycle Time	—	—	10	ms	
T <sub>PINT</sub>	Internally Timed Programming Operation Time	—	—	8	ms	Program Memory and ID
		—	—	13	ms	Configuration Words and Data Flash Memory (EEPROM)
T <sub>PEXT</sub>	Delay Required between Begin Externally Timed Programming and End Externally Timed Programming Commands	1	—	2.1	ms	<b>(Note 3)</b>
T <sub>DIS</sub>	Delay Required after End Externally Timed Programming Command	300	—	—	μs	
T <sub>EXIT</sub>	Time Delay when Exiting Program/Verify Mode	1	—	—	μs	

**Notes:**

1. Bulk Erased devices default to Brown-out Reset enabled with BORV = 1 (low trip point). V<sub>DDMIN</sub> is the V<sub>BOR</sub> threshold (with BORV = 1) when performing Low-Voltage Programming on a Bulk Erased device to ensure that the device is not held in Brown-out Reset.
2. The hardware requires V<sub>DD</sub> to be above the BOR threshold in order to perform Bulk Erase operations. This threshold does not depend on the BORV Configuration bit setting. Refer to the microcontroller device data sheet specifications for min./typ./max limits of the V<sub>BOR</sub> level.
3. Externally timed writes are not supported for Configuration Words.

## 5. Appendix A: Revision History

Doc Rev.	Date	Comments
B	06/2024	Updated programming and erase times.
A	02/2024	Initial Document Release.

## 6. Appendix B: Pinout Descriptions and Configuration Words

**Table 6-1.** Programming Pin Locations By Package Type

Device	Package	Package Code	V <sub>DD</sub>	V <sub>SS</sub>	MCLR		ICSPCLK		ICSPDAT	
			PIN	PIN	PIN	PORT	PIN	PORT	PIN	PORT
PIC16F17524 PIC16F17525 PIC16F17526	14-Pin PDIP	P	1	14	4	RA3	12	RA1	13	RA0
	14-Pin SOIC	SL	1	14	4	RA3	12	RA1	13	RA0
	14-Pin TSSOP	ST	1	14	4	RA3	12	RA1	13	RA0
	16-Pin VQFN	ML	16	13	3	RA3	11	RA1	12	RA0
PIC16F17544 PIC16F17545 PIC16F17546	20-Pin PDIP	P	1	20	4	RA3	18	RA1	19	RA0
	20-Pin SOIC	SO	1	20	4	RA3	18	RA1	19	RA0
	20-Pin SSOP	SS	1	20	4	RA3	18	RA1	19	RA0
	20-Pin VQFN	ML	18	17	1	RA3	15	RA1	16	RA0
PIC16F17554 PIC16F17555 PIC16F17556	28-Pin SPDIP	SP	20	8, 19	1	RE3	27	RB6	28	RB7
	28-Pin SOIC	SO	20	8, 19	1	RE3	27	RB6	28	RB7
	28-Pin SSOP	SS	20	8, 19	1	RE3	27	RB6	28	RB7
	28-Pin VQFN	STX	17	5, 16	26	RE3	24	RB6	25	RB7
PIC16F17574 PIC16F17575 PIC16F17576	40-Pin PDIP	P	11, 32	12, 31	1	RE3	39	RB6	40	RB7
	40-Pin QFN	MP	7, 26	6, 27	16	RE3	14	RB6	15	RB7
	44-Pin TQFP	PT	7, 28	6, 29	18	RE3	16	RB6	17	RB7

**Note:** The most current drawings are located in the Microchip Packaging Specification, DS0000049 ([www.microchip.com/packaging](http://www.microchip.com/packaging)).

## 6.1 CONFIG1

Name: CONFIG1

Offset: 0x8007

Configuration Word 1

Bit	15	14	13	12	11	10	9	8
			FCMEN	VDDAR	CSWEN			CLKOUTEN
Access			R/W	R/W	R/W			R/W
Reset			1	1	1			1
Bit	7	6	5	4	3	2	1	0
		RSTOSC[2:0]				FEXTOSC[2:0]		
Access		R/W	R/W	R/W		R/W	R/W	R/W
Reset		1	1	1		1	1	1

### Bit 13 – FCMEN Fail-Safe Clock Monitor Enable

Value	Description
1	Fail-Safe Clock Monitor is enabled
0	Fail-Safe Clock Monitor is disabled

### Bit 12 – VDDAR $V_{DD}$ Analog Range Calibration Selection

Value	Description
1	Internal analog systems are calibrated for operation between $V_{DD} = 2.3V - 5.5V$
0	Internal analog systems are calibrated for operation between $V_{DD} = 1.8V - 3.6V$

### Bit 11 – CSWEN Clock Switch Enable

Value	Description
1	Writing to NOSC and NDIV is allowed
0	The NOSC and NDIV bit fields cannot be changed by user software

### Bit 8 – CLKOUTEN Clock Out Enable

Value	Description
1	CLKOUT function is disabled; I/O function on CLKOUT pin
0	CLKOUT function is enabled; $F_{OSC}/4$ clock appears on CLKOUT pin

### Bits 6:4 – RSTOSC[2:0] Power-up Default Value for the NOSC/COSC bits

Selects the oscillator source used by user software.

Value	Description
111	EXTOSC operating per the FEXTOSC bits
110	HFINTOSC = 1 MHz (FRQ = 4 MHz, CDIV = 4:1)
101	LFINTOSC
100	SOSC
011	Reserved
010	EXTOSC with 4x PLL, EXTOSC operating per FEXTOSC bits
001	HFINTOSC = 16 MHz (FRQ = 16 MHz, CDIV = 1:1)
000	HFINTOSC = 32 MHz (FRQ = 32 MHz, CDIV = 1:1)

### Bits 2:0 – FEXTOSC[2:0] External Oscillator Mode Selection

Value	Description
111	ECH (16 MHz and higher)
110	Reserved
101	ECL (below 16 MHz)
100	Oscillator not enabled

Value	Description
011	Reserved
010	HS (crystal oscillator) above 4 MHz
001	XT (crystal oscillator) between 100 kHz and 4 MHz
000	LP (crystal oscillator) 32 kHz

## 6.2 CONFIG2

Name: CONFIG2

Offset: 0x8008

Configuration Word 2

Bit	15	14	13	12	11	10	9	8
			DEBUG	STVREN	PPS1WAY		BORV	DACAUTOEN
Access			R/W	R/W	R/W		R/W	R/W
Reset			1	1	1		1	1
Bit	7	6	5	4	3	2	1	0
	BOREN[1:0]		LPBOREN			PWRTS[1:0]		MCLRE
Access	R/W	R/W	R/W			R/W	R/W	R/W
Reset	1	1	1			1	1	1

### Bit 13 – **DEBUG** Debugger Enable<sup>(1)</sup>

Value	Description
1	Background debugger disabled
0	Background debugger enabled

### Bit 12 – **STVREN** Stack Overflow/Underflow Reset Enable

Value	Description
1	Stack Overflow or Underflow will cause a Reset
0	Stack Overflow or Underflow will not cause a Reset

### Bit 11 – **PPS1WAY** PPSLOCKED One-Way Set Enable

Value	Description
1	The PPSLOCKED bit can only be set once after an unlocking sequence is executed; once PPSLOCKED is set, all future changes to PPS registers are prevented
0	The PPSLOCKED bit can be set and cleared as needed (unlocking sequence is required)

### Bit 9 – **BORV** Brown-out Reset (BOR) Voltage Selection<sup>(2)</sup>

Value	Description
1	Brown-out Reset voltage ( $V_{BOR}$ ) set to 1.9V
0	Brown-out Reset voltage ( $V_{BOR}$ ) set to 2.65V

### Bit 8 – **DACAUTOEN** DAC Buffer Automatic Range Select Enable

Value	Description
1	DAC Buffer reference range is determined by the REFRNG bit of DACxCON
0	DAC Buffer reference range is automatically determined by module hardware

### Bits 7:6 – **BOREN[1:0]** Brown-out Reset (BOR) Enable<sup>(3)</sup>

Value	Description
11	Brown-out Reset disabled
10	Brown-out Reset enabled while running, disabled in Sleep; the SBOREN bit is ignored
01	Brown-out Reset enabled according to SBOREN
00	Brown-out Reset enabled, the SBOREN bit is ignored

### Bit 5 – **LPBOREN** Low-Power BOR Enable

Value	Description
1	Low-Power BOR disabled
0	Low-Power BOR enabled

### Bits 2:1 – **PWRTS[1:0]** Power-Up Timer (PWRT) Selection

Value	Description
11	PWRT disabled
10	PWRT is set at 64 ms
01	PWRT is set at 16 ms
00	PWRT is set at 1 ms

#### Bit 0 – MCLRE Master Clear ( $\overline{\text{MCLR}}$ ) Enable

Value	Condition	Description
x	If LVP = 1	MCLR pin is MCLR
1	If LVP = 0	MCLR pin is MCLR
0	If LVP = 0	MCLR pin function is port-defined function

#### Notes:

1. The  $\overline{\text{DEBUG}}$  bit is managed automatically by device development tools including debuggers and programmers. For normal device operation, this bit needs to be maintained as a '1'.
2. The higher voltage selection is recommended for operation at or above 16 MHz.
3. When enabled, Brown-out Reset voltage ( $V_{\text{BOR}}$ ) is set by the BORV bit.

## 6.3 CONFIG3

Name: CONFIG3

Offset: 0x8009

Configuration Word 3

Bit	15	14	13	12	11	10	9	8
			WDTCCS[2:0]			WDTCWS[2:0]		
Access			R/W	R/W	R/W	R/W	R/W	R/W
Reset			1	1	1	1	1	1
Bit	7	6	5	4	3	2	1	0
			WDTE[1:0]		WDTCPSP[4:0]			
Access		R/W	R/W	R/W	R/W	R/W	R/W	R/W
Reset		1	1	1	1	1	1	1

### Bits 13:11 – WDTCCS[2:0] WDT Input Clock Selector

Value	Condition	Description
x	WDTE = 00	These bits have no effect
111	WDTE ≠ 00	Software control
110 to 011	WDTE ≠ 00	Reserved
010	WDTE ≠ 00	WDT reference clock is the SOSC
001	WDTE ≠ 00	WDT reference clock is the 31.25 kHz MFINTOSC
000	WDTE ≠ 00	WDT reference clock is the 31.0 kHz LFINTOSC

### Bits 10:8 – WDTCWS[2:0] WDT Window Select

WDTCWS	WDTCON1[WINDOW] at POR			Software Control of WINDOW	Keyed Access Required?
	Value	Window Delay Percent of Time	Window Opening Percent of Time		
111	111	n/a	100	Yes	No
110	110	n/a	100	No	Yes
101	101	25	75		
100	100	37.5	62.5		
011	011	50	50		
010	010	62.5	37.5		
001	001	75	25		
000	000	87.5	12.5		

### Bits 6:5 – WDTE[1:0] WDT Operating Mode

Value	Description
11	WDT enabled regardless of Sleep; the SEN bit in WDTCON0 is ignored
10	WDT enabled while Sleep = 0, suspended when Sleep = 1; the SEN bit in WDTCON0 is ignored
01	WDT enabled/disabled by the SEN bit in WDTCON0
00	WDT disabled, the SEN bit in WDTCON0 is ignored

### Bits 4:0 – WDTCPSP[4:0] WDT Period Select

WDTCPSP	WDTCON0[WDTSP] at POR				Software Control of WDTSP?
	Value	Divider Ratio	Typical Time-Out (F <sub>IN</sub> = 31 kHz)		
11111	01011	1:65536	2 <sup>16</sup>	2s	Yes
11110 to 10011	11110 to 10011	1:32	2 <sup>5</sup>	1 ms	No
10010	10010	1:8388608	2 <sup>23</sup>	256s	No

.....continued

WDTGPS	WDTCON0[WDTGPS] at POR				Software Control of WDTGPS?
	Value	Divider Ratio		Typical Time-Out ( $F_{IN} = 31$ kHz)	
10001	10001	1:4194304	$2^{22}$	128s	No
10000	10000	1:2097152	$2^{21}$	64s	No
01111	01111	1:1048576	$2^{20}$	32s	No
01110	01110	1:524288	$2^{19}$	16s	No
01101	01101	1:262144	$2^{18}$	8s	No
01100	01100	1:131072	$2^{17}$	4s	No
01011	01011	1:65536	$2^{16}$	2s	No
01010	01010	1:32768	$2^{15}$	1s	No
01001	01001	1:16384	$2^{14}$	512 ms	No
01000	01000	1:8192	$2^{13}$	256 ms	No
00111	00111	1:4096	$2^{12}$	128 ms	No
00110	00110	1:2048	$2^{11}$	64 ms	No
00101	00101	1:1024	$2^{10}$	32 ms	No
00100	00100	1:512	$2^9$	16 ms	No
00011	00011	1:256	$2^8$	8 ms	No
00010	00010	1:128	$2^7$	4 ms	No
00001	00001	1:64	$2^6$	2 ms	No
00000	00000	1:32	$2^5$	1 ms	No

## 6.4 CONFIG4

Name: CONFIG4

Offset: 0x800A

Configuration Word 4

Bit	15	14	13	12	11	10	9	8
			LVP		WRTSAF	WRTD	WRTC	WRTB
Access			R/W		R/W	R/W	R/W	R/W
Reset			1		1	1	1	1
Bit	7	6	5	4	3	2	1	0
	WRTAPP			SAFEN	BBEN	BBSIZE[2:0]		
Access	R/W			R/W	R/W	R/W	R/W	R/W
Reset	1			1	1	1	1	1

### Bit 13 – LVP Low-Voltage Programming Enable<sup>(1)</sup>

Value	Description
1	Low-Voltage Programming is enabled. MCLR/V <sub>PP</sub> pin function is MCLR. The MCLRE bit is ignored.
0	High voltage (HV) on MCLR/V <sub>PP</sub> must be used for programming

### Bit 11 – WRTSAF Storage Area Flash (SAF) Write Protection<sup>(2,3)</sup>

Value	Description
1	SAF is not write-protected
0	SAF is write-protected

### Bit 10 – WRTD Data EEPROM Write Protection<sup>(2)</sup>

Value	Description
1	Data EEPROM is not write-protected
0	Data EEPROM is write-protected

### Bit 9 – WRTC Configuration Registers Write Protection<sup>(2)</sup>

Value	Description
1	Configuration registers are not write-protected
0	Configuration registers are write-protected

### Bit 8 – WRTB Boot Block Write Protection<sup>(2,4)</sup>

Value	Description
1	Boot Block is not write-protected
0	Boot Block is write-protected

### Bit 7 – WRTAPP Application Block Write Protection<sup>(2)</sup>

Value	Description
1	Application Block is not write-protected
0	Application Block is write-protected

### Bit 4 – SAFEN Storage Area Flash (SAF) Enable<sup>(2)</sup>

Value	Description
1	SAF is disabled
0	SAF is enabled

### Bit 3 – BBEN Boot Block Enable<sup>(2)</sup>

Value	Description
1	Boot Block is disabled
0	Boot Block is enabled

Bits 2:0 – BBSIZE[2:0] Boot Block Size Selection<sup>(5,6)</sup>

Table 6-2. Boot Block Size

BBEN	BBSIZE	End Address of Boot Block	Boot Block Size (words)		
			PIC16F175x4	PIC16F175x5	PIC16F175x6
1	xxx	-	-		
0	111	01FFh	512		
0	110	03FFh	1024		
0	101	07FFh	2048		
0	100	0FFFh	...(6)	4096	
0	011	1FFFh	...(6)		8192
0	010	3FFFh	...(6)		
0	001	3FFFh	...(6)		
0	000	3FFFh	...(6)		

**Notes:**

1. The LVP bit cannot be written (to zero) while operating from the LVP programming interface. The purpose of this rule is to prevent the user from dropping out of LVP mode while programming from LVP mode, or accidentally eliminating LVP mode from the Configuration state.
2. Once protection is enabled through ICSP or a self-write, it can only be reset through a Bulk Erase.
3. Applicable only if  $\overline{\text{SAFEN}} = 0$ .
4. Applicable only if  $\overline{\text{BBEN}} = 0$ .
5. BBSIZE[2:0] bits can only be changed when  $\overline{\text{BBEN}} = 1$ . Once  $\overline{\text{BBEN}} = 0$ , BBSIZE[2:0] can only be changed through a Bulk Erase.
6. The maximum Boot Block size is half of the user program memory size. Any selection that will exceed the half of a device's program memory will default to a maximum Boot Block size of half PFM.

## 6.5 CONFIG5

**Name:** CONFIG5

**Offset:** 0x800B

Configuration Word 5<sup>(1)</sup>

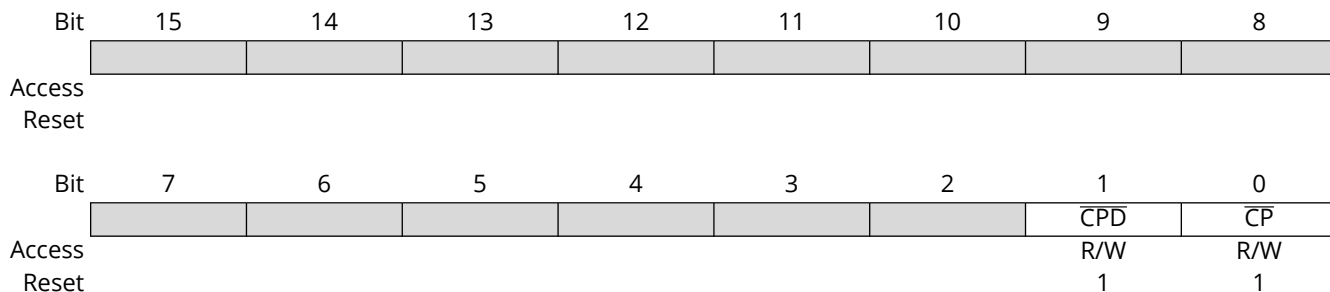

**Bit 1 –  $\overline{\text{CPD}}$  Data EEPROM Code Protection<sup>(2)</sup>**

Value	Description
1	Data EEPROM code protection is disabled
0	Data EEPROM code protection is enabled

**Bit 0 –  $\overline{\text{CP}}$  User Program Flash Memory (PFM) Code Protection<sup>(2)</sup>**

Value	Description
1	User PFM code protection is disabled
0	User PFM code protection is enabled

### Notes:

1. Since device code protection takes effect immediately, this Configuration Word may be written last.
2. Once code protection is enabled, it can only be removed through a Bulk Erase.

## Microchip Information

### The Microchip Website

Microchip provides online support via our website at [www.microchip.com/](http://www.microchip.com/). This website is used to make files and information easily available to customers. Some of the content available includes:

- **Product Support** – Data sheets and errata, application notes and sample programs, design resources, user’s guides and hardware support documents, latest software releases and archived software
- **General Technical Support** – Frequently Asked Questions (FAQs), technical support requests, online discussion groups, Microchip design partner program member listing
- **Business of Microchip** – Product selector and ordering guides, latest Microchip press releases, listing of seminars and events, listings of Microchip sales offices, distributors and factory representatives

### Product Change Notification Service

Microchip’s product change notification service helps keep customers current on Microchip products. Subscribers will receive email notification whenever there are changes, updates, revisions or errata related to a specified product family or development tool of interest.

To register, go to [www.microchip.com/pcn](http://www.microchip.com/pcn) and follow the registration instructions.

### Customer Support

Users of Microchip products can receive assistance through several channels:

- Distributor or Representative
- Local Sales Office
- Embedded Solutions Engineer (ESE)
- Technical Support

Customers should contact their distributor, representative or ESE for support. Local sales offices are also available to help customers. A listing of sales offices and locations is included in this document.

Technical support is available through the website at: [www.microchip.com/support](http://www.microchip.com/support)

### Microchip Devices Code Protection Feature

Note the following details of the code protection feature on Microchip products:

- Microchip products meet the specifications contained in their particular Microchip Data Sheet.
- Microchip believes that its family of products is secure when used in the intended manner, within operating specifications, and under normal conditions.
- Microchip values and aggressively protects its intellectual property rights. Attempts to breach the code protection features of Microchip product is strictly prohibited and may violate the Digital Millennium Copyright Act.
- Neither Microchip nor any other semiconductor manufacturer can guarantee the security of its code. Code protection does not mean that we are guaranteeing the product is “unbreakable”. Code protection is constantly evolving. Microchip is committed to continuously improving the code protection features of our products.

### Legal Notice

This publication and the information herein may be used only with Microchip products, including to design, test, and integrate Microchip products with your application. Use of this information in any other manner violates these terms. Information regarding device applications is provided only for your convenience and may be superseded by updates. It is your responsibility to ensure

that your application meets with your specifications. Contact your local Microchip sales office for additional support or, obtain additional support at [www.microchip.com/en-us/support/design-help/client-support-services](http://www.microchip.com/en-us/support/design-help/client-support-services).

THIS INFORMATION IS PROVIDED BY MICROCHIP "AS IS". MICROCHIP MAKES NO REPRESENTATIONS OR WARRANTIES OF ANY KIND WHETHER EXPRESS OR IMPLIED, WRITTEN OR ORAL, STATUTORY OR OTHERWISE, RELATED TO THE INFORMATION INCLUDING BUT NOT LIMITED TO ANY IMPLIED WARRANTIES OF NON-INFRINGEMENT, MERCHANTABILITY, AND FITNESS FOR A PARTICULAR PURPOSE, OR WARRANTIES RELATED TO ITS CONDITION, QUALITY, OR PERFORMANCE.

IN NO EVENT WILL MICROCHIP BE LIABLE FOR ANY INDIRECT, SPECIAL, PUNITIVE, INCIDENTAL, OR CONSEQUENTIAL LOSS, DAMAGE, COST, OR EXPENSE OF ANY KIND WHATSOEVER RELATED TO THE INFORMATION OR ITS USE, HOWEVER CAUSED, EVEN IF MICROCHIP HAS BEEN ADVISED OF THE POSSIBILITY OR THE DAMAGES ARE FORESEEABLE. TO THE FULLEST EXTENT ALLOWED BY LAW, MICROCHIP'S TOTAL LIABILITY ON ALL CLAIMS IN ANY WAY RELATED TO THE INFORMATION OR ITS USE WILL NOT EXCEED THE AMOUNT OF FEES, IF ANY, THAT YOU HAVE PAID DIRECTLY TO MICROCHIP FOR THE INFORMATION.

Use of Microchip devices in life support and/or safety applications is entirely at the buyer's risk, and the buyer agrees to defend, indemnify and hold harmless Microchip from any and all damages, claims, suits, or expenses resulting from such use. No licenses are conveyed, implicitly or otherwise, under any Microchip intellectual property rights unless otherwise stated.

## Trademarks

The Microchip name and logo, the Microchip logo, Adaptec, AVR, AVR logo, AVR Freaks, BesTime, BitCloud, CryptoMemory, CryptoRF, dsPIC, flexPWR, HELDO, IGLOO, JukeBlox, KeeLoq, Kleer, LANCheck, LinkMD, maXStylus, maXTouch, MediaLB, megaAVR, Microsemi, Microsemi logo, MOST, MOST logo, MPLAB, OptoLyzer, PIC, picoPower, PICSTART, PIC32 logo, PolarFire, Prochip Designer, QTouch, SAM-BA, SenGenuity, SpyNIC, SST, SST Logo, SuperFlash, Symmetricom, SyncServer, Tachyon, TimeSource, tinyAVR, UNI/O, Vectron, and XMEGA are registered trademarks of Microchip Technology Incorporated in the U.S.A. and other countries.

AgileSwitch, ClockWorks, The Embedded Control Solutions Company, EtherSynch, Flashtec, Hyper Speed Control, HyperLight Load, Libero, motorBench, mTouch, Powermite 3, Precision Edge, ProASIC, ProASIC Plus, ProASIC Plus logo, Quiet-Wire, SmartFusion, SyncWorld, TimeCesium, TimeHub, TimePictra, TimeProvider, and ZL are registered trademarks of Microchip Technology Incorporated in the U.S.A.

Adjacent Key Suppression, AKS, Analog-for-the-Digital Age, Any Capacitor, AnyIn, AnyOut, Augmented Switching, BlueSky, BodyCom, Clockstudio, CodeGuard, CryptoAuthentication, CryptoAutomotive, CryptoCompanion, CryptoController, dsPICDEM, dsPICDEM.net, Dynamic Average Matching, DAM, ECAN, Espresso T1S, EtherGREEN, EyeOpen, GridTime, IdealBridge, IGaT, In-Circuit Serial Programming, ICSP, INICnet, Intelligent Paralleling, IntelliMOS, Inter-Chip Connectivity, JitterBlocker, Knob-on-Display, MarginLink, maxCrypto, maxView, memBrain, Minda, MiWi, MPASM, MPF, MPLAB Certified logo, MPLIB, MPLINK, mSiC, MultiTRAK, NetDetach, Omniscient Code Generation, PICDEM, PICDEM.net, PICkit, PICtail, Power MOS IV, Power MOS 7, PowerSmart, PureSilicon, QMatrix, REAL ICE, Ripple Blocker, RTAX, RTG4, SAM-ICE, Serial Quad I/O, simpleMAP, SimpliPHY, SmartBuffer, SmartHLS, SMART-I.S., storClad, SQI, SuperSwitcher, SuperSwitcher II, Switchtec, SynchroPHY, Total Endurance, Trusted Time, TSHARC, Turing, USBCheck, VariSense, VectorBlox, VeriPHY, ViewSpan, WiperLock, XpressConnect, and ZENA are trademarks of Microchip Technology Incorporated in the U.S.A. and other countries.

SQTP is a service mark of Microchip Technology Incorporated in the U.S.A.

The Adaptec logo, Frequency on Demand, Silicon Storage Technology, and Symmcom are registered trademarks of Microchip Technology Inc. in other countries.

GestIC is a registered trademark of Microchip Technology Germany II GmbH & Co. KG, a subsidiary of Microchip Technology Inc., in other countries.

All other trademarks mentioned herein are property of their respective companies.

© 2024, Microchip Technology Incorporated and its subsidiaries. All Rights Reserved.

ISBN: 978-1-6683-4454-5

## **Quality Management System**

For information regarding Microchip's Quality Management Systems, please visit [www.microchip.com/quality](http://www.microchip.com/quality).

# Worldwide Sales and Service

AMERICAS	ASIA/PACIFIC	ASIA/PACIFIC	EUROPE
<p><b>Corporate Office</b> 2355 West Chandler Blvd. Chandler, AZ 85224-6199 Tel: 480-792-7200 Fax: 480-792-7277 Technical Support: <a href="http://www.microchip.com/support">www.microchip.com/support</a> Web Address: <a href="http://www.microchip.com">www.microchip.com</a></p> <p><b>Atlanta</b> Duluth, GA Tel: 678-957-9614 Fax: 678-957-1455</p> <p><b>Austin, TX</b> Tel: 512-257-3370</p> <p><b>Boston</b> Westborough, MA Tel: 774-760-0087 Fax: 774-760-0088</p> <p><b>Chicago</b> Itasca, IL Tel: 630-285-0071 Fax: 630-285-0075</p> <p><b>Dallas</b> Addison, TX Tel: 972-818-7423 Fax: 972-818-2924</p> <p><b>Detroit</b> Novi, MI Tel: 248-848-4000</p> <p><b>Houston, TX</b> Tel: 281-894-5983</p> <p><b>Indianapolis</b> Noblesville, IN Tel: 317-773-8323 Fax: 317-773-5453 Tel: 317-536-2380</p> <p><b>Los Angeles</b> Mission Viejo, CA Tel: 949-462-9523 Fax: 949-462-9608 Tel: 951-273-7800</p> <p><b>Raleigh, NC</b> Tel: 919-844-7510</p> <p><b>New York, NY</b> Tel: 631-435-6000</p> <p><b>San Jose, CA</b> Tel: 408-735-9110 Tel: 408-436-4270</p> <p><b>Canada - Toronto</b> Tel: 905-695-1980 Fax: 905-695-2078</p>	<p><b>Australia - Sydney</b> Tel: 61-2-9868-6733</p> <p><b>China - Beijing</b> Tel: 86-10-8569-7000</p> <p><b>China - Chengdu</b> Tel: 86-28-8665-5511</p> <p><b>China - Chongqing</b> Tel: 86-23-8980-9588</p> <p><b>China - Dongguan</b> Tel: 86-769-8702-9880</p> <p><b>China - Guangzhou</b> Tel: 86-20-8755-8029</p> <p><b>China - Hangzhou</b> Tel: 86-571-8792-8115</p> <p><b>China - Hong Kong SAR</b> Tel: 852-2943-5100</p> <p><b>China - Nanjing</b> Tel: 86-25-8473-2460</p> <p><b>China - Qingdao</b> Tel: 86-532-8502-7355</p> <p><b>China - Shanghai</b> Tel: 86-21-3326-8000</p> <p><b>China - Shenyang</b> Tel: 86-24-2334-2829</p> <p><b>China - Shenzhen</b> Tel: 86-755-8864-2200</p> <p><b>China - Suzhou</b> Tel: 86-186-6233-1526</p> <p><b>China - Wuhan</b> Tel: 86-27-5980-5300</p> <p><b>China - Xian</b> Tel: 86-29-8833-7252</p> <p><b>China - Xiamen</b> Tel: 86-592-2388138</p> <p><b>China - Zhuhai</b> Tel: 86-756-3210040</p>	<p><b>India - Bangalore</b> Tel: 91-80-3090-4444</p> <p><b>India - New Delhi</b> Tel: 91-11-4160-8631</p> <p><b>India - Pune</b> Tel: 91-20-4121-0141</p> <p><b>Japan - Osaka</b> Tel: 81-6-6152-7160</p> <p><b>Japan - Tokyo</b> Tel: 81-3-6880-3770</p> <p><b>Korea - Daegu</b> Tel: 82-53-744-4301</p> <p><b>Korea - Seoul</b> Tel: 82-2-554-7200</p> <p><b>Malaysia - Kuala Lumpur</b> Tel: 60-3-7651-7906</p> <p><b>Malaysia - Penang</b> Tel: 60-4-227-8870</p> <p><b>Philippines - Manila</b> Tel: 63-2-634-9065</p> <p><b>Singapore</b> Tel: 65-6334-8870</p> <p><b>Taiwan - Hsin Chu</b> Tel: 886-3-577-8366</p> <p><b>Taiwan - Kaohsiung</b> Tel: 886-7-213-7830</p> <p><b>Taiwan - Taipei</b> Tel: 886-2-2508-8600</p> <p><b>Thailand - Bangkok</b> Tel: 66-2-694-1351</p> <p><b>Vietnam - Ho Chi Minh</b> Tel: 84-28-5448-2100</p>	<p><b>Austria - Wels</b> Tel: 43-7242-2244-39 Fax: 43-7242-2244-393</p> <p><b>Denmark - Copenhagen</b> Tel: 45-4485-5910 Fax: 45-4485-2829</p> <p><b>Finland - Espoo</b> Tel: 358-9-4520-820</p> <p><b>France - Paris</b> Tel: 33-1-69-53-63-20 Fax: 33-1-69-30-90-79</p> <p><b>Germany - Garching</b> Tel: 49-8931-9700</p> <p><b>Germany - Haan</b> Tel: 49-2129-3766400</p> <p><b>Germany - Heilbronn</b> Tel: 49-7131-72400</p> <p><b>Germany - Karlsruhe</b> Tel: 49-721-625370</p> <p><b>Germany - Munich</b> Tel: 49-89-627-144-0 Fax: 49-89-627-144-44</p> <p><b>Germany - Rosenheim</b> Tel: 49-8031-354-560</p> <p><b>Israel - Hod Hasharon</b> Tel: 972-9-775-5100</p> <p><b>Italy - Milan</b> Tel: 39-0331-742611 Fax: 39-0331-466781</p> <p><b>Italy - Padova</b> Tel: 39-049-7625286</p> <p><b>Netherlands - Drunen</b> Tel: 31-416-690399 Fax: 31-416-690340</p> <p><b>Norway - Trondheim</b> Tel: 47-72884388</p> <p><b>Poland - Warsaw</b> Tel: 48-22-3325737</p> <p><b>Romania - Bucharest</b> Tel: 40-21-407-87-50</p> <p><b>Spain - Madrid</b> Tel: 34-91-708-08-90 Fax: 34-91-708-08-91</p> <p><b>Sweden - Gothenberg</b> Tel: 46-31-704-60-40</p> <p><b>Sweden - Stockholm</b> Tel: 46-8-5090-4654</p> <p><b>UK - Wokingham</b> Tel: 44-118-921-5800 Fax: 44-118-921-5820</p>