

# 16-Kbit I<sup>2</sup>C Serial EEPROM with Unique 128-Bit Serial Number, Industrial Grade AT24CS16



## Features

- Low-Voltage Operation:
  - $V_{CC} = 1.7V$  to  $5.5V$
- Internally Organized as 2,048 x 8 (16K)
- 128-Bit Unique Factory-Programmed Serial Number
  - Permanent read-only value
  - Unique across entire CS Series of Serial EEPROMs
- Industrial Temperature Range:  $-40^{\circ}C$  to  $+85^{\circ}C$
- I<sup>2</sup>C-Compatible (Two-Wire) Serial Interface:
  - 100 kHz Standard Mode, 1.7V to 5.5V
  - 400 kHz Fast Mode, 1.7V to 5.5V
  - 1 MHz Fast Mode Plus (FM+), 2.5V to 5.5V
- Schmitt Triggers, Filtered Inputs for Noise Suppression
- Bidirectional Data Transfer Protocol
- Write-Protect Pin for Full Array Hardware Data Protection
- Ultra-Low Active Current (3 mA maximum) and Standby Current (6  $\mu A$  maximum)
- 16-Byte Page Write Mode:
  - Partial page writes allowed
- Random and Sequential Read Modes
- Self-Timed Write Cycle within 5 ms Maximum
- ESD Protection > 4,000V
- High Reliability:
  - Endurance: 1,000,000 write cycles
  - Data retention: 100 years
- RoHS Compliant
- Die Sale Options: Wafer Form and Tape and Reel Available

## Packages

- 8-Lead SOIC, 8-Lead TSSOP, 8-Pad UDFN and 5-Lead SOT23

## Table of Contents

Features.....	1
Packages.....	1
1. Package Types (not to scale).....	4
2. Pin Descriptions.....	5
2.1. Ground.....	5
2.2. Serial Data (SDA).....	5
2.3. Serial Clock (SCL).....	5
2.4. Write-Protect (WP).....	5
2.5. Device Power Supply ( $V_{CC}$ ).....	6
3. Description.....	7
3.1. System Configuration Using Two-Wire Serial EEPROMs .....	7
3.2. Block Diagram.....	8
4. Electrical Characteristics.....	9
4.1. Absolute Maximum Ratings.....	9
4.2. DC and AC Operating Range.....	9
4.3. DC Characteristics.....	9
4.4. AC Characteristics.....	10
4.5. Electrical Specifications.....	11
5. Device Operation and Communication.....	12
5.1. Clock and Data Transition Requirements.....	12
5.2. Start and Stop Conditions.....	12
5.3. Acknowledge and No-Acknowledge.....	13
5.4. Standby Mode.....	13
5.5. Software Reset.....	13
6. Memory Organization.....	15
6.1. Device Addressing.....	15
7. Write Operations.....	16
7.1. Byte Write.....	16
7.2. Page Write.....	16
7.3. Acknowledge Polling.....	17
7.4. Write Cycle Timing.....	17
7.5. Write Protection.....	18
8. Read Operations.....	19
8.1. Current Address Read.....	19
8.2. Random Read.....	19
8.3. Sequential Read.....	20
8.4. Serial Number Read.....	21
9. Device Default Condition from Microchip.....	23
10. Packaging Information.....	24

10.1. Package Marking Information.....	24
11. Revision History.....	37
12. Product Identification System.....	38
Microchip Information.....	39
Trademarks.....	39
Legal Notice.....	39
Microchip Devices Code Protection Feature.....	39
Product Page Links.....	40

## 1. Package Types (not to scale)

**8-Lead SOIC/TSSOP**  
(Top View)

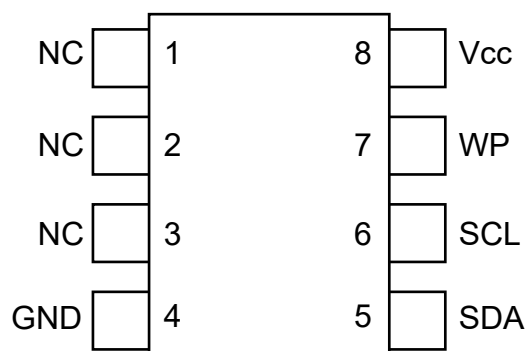

**8-Pad UDFN**  
(Top View)

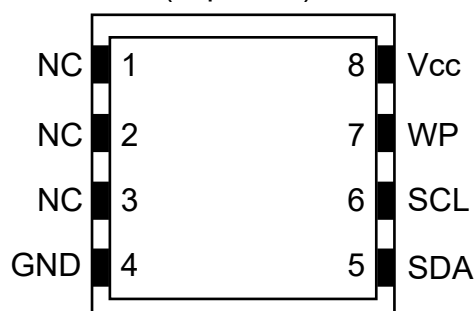

**5-Lead SOT23**  
(Top View)

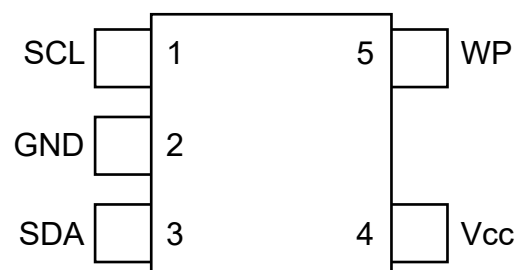

## 2. Pin Descriptions

The descriptions of the pins are listed in [Table 2-1](#).

**Table 2-1.** Pin Function Table

Name	8-Lead SOIC	8-Lead TSSOP	8-Pad UDFN <sup>(1)</sup>	5-Lead SOT23	Function
NC	1	1	1	—	No Connect
NC	2	2	2	—	No Connect
NC	3	3	3	—	No Connect
GND	4	4	4	2	Ground
SDA	5	5	5	3	Serial Data
SCL	6	6	6	1	Serial Clock
WP <sup>(2)</sup>	7	7	7	5	Write-Protect
V <sub>CC</sub>	8	8	8	4	Device Power Supply

### Notes:

1. The exposed pad on this package can be connected to GND or left floating.
2. If the WP pin is not driven, it is internally pulled down to GND. In order to operate in a wide variety of application environments, the pull-down mechanism is intentionally designed to be somewhat strong. Once this pin is biased above the CMOS input buffer's trip point ( $\sim 0.5 \times V_{CC}$ ), the pull-down mechanism disengages. Microchip recommends connecting these pins to a known state whenever possible.

### 2.1. Ground

The ground reference for the power supply. GND should be connected to the system ground.

### 2.2. Serial Data (SDA)

The SDA pin is an open-drain bidirectional input/output pin used to serially transfer data to and from the device. The SDA pin must be pulled high using an external pull-up resistor (not to exceed 10 k $\Omega$  in value) and may be wire-ORed with any number of other open-drain or open-collector pins from other devices on the same bus.

### 2.3. Serial Clock (SCL)

The SCL pin is used to provide a clock to the device and to control the flow of data to and from the device. Command and input data present on the SDA pin are always latched in on the rising edge of SCL, while output data on the SDA pin are clocked out on the falling edge of SCL. The SCL pin must either be forced high when the serial bus is idle or pulled high using an external pull-up resistor.

### 2.4. Write-Protect (WP)

The write-protect input, when connected to GND, allows normal write operations. When the WP pin is connected directly to V<sub>CC</sub>, all write operations to the protected memory are inhibited.

If the pin is left floating, the WP pin will be internally pulled down to GND. However, due to capacitive coupling that may appear in customer applications, connecting the WP pin to a known state is recommended. When using a pull-up resistor, using 10 k $\Omega$  or less is recommended.

**Table 2-2.** Write-Protect

WP Pin Status	Part of the Array Protected
At V <sub>CC</sub>	Full Array
At GND	Normal Write Operations

## 2.5. Device Power Supply ( $V_{CC}$ )

The Device Power Supply ( $V_{CC}$ ) pin is used to supply the source voltage to the device. Operations at invalid  $V_{CC}$  voltages may produce spurious results and should not be attempted.

### 3. Description

The AT24CS16 provides 16,384 bits of Serial Electrically Erasable and Programmable Read-Only Memory (EEPROM) organized as 2,048 words of 8 bits each. This device is optimized for use in many industrial and commercial applications where low-power and low-voltage operation are essential. The device is available in space-saving 8-lead SOIC, 8-lead TSSOP, 8-pad UDFN and 5-lead SOT23 packages. All packages operate from 1.7V to 5.5V.

The AT24CS16 provides the additional feature of a factory-programmed, ensured unique 128-bit serial number while maintaining all of the traditional features available in the 16-Kbit Serial EEPROM. The time-consuming step of performing and ensuring true serialization of products on a manufacturing line can be removed from the production flow by employing the CS Series Serial EEPROM. The 128-bit serial number is programmed and permanently locked from future writing during the Microchip production process. Further, this 128-bit location does not consume any of the user read/write area of the 16-Kbit Serial EEPROM. The uniqueness of the serial number is ensured across the entire CS Series of Serial EEPROMs, regardless of the size of the memory array or the type of interface protocol. This means that as an application's needs for memory size or interface protocol evolve in future generations, any previously deployed serial number from any Microchip CS Series Serial EEPROM part will remain valid.

#### 3.1. System Configuration Using Two-Wire Serial EEPROMs

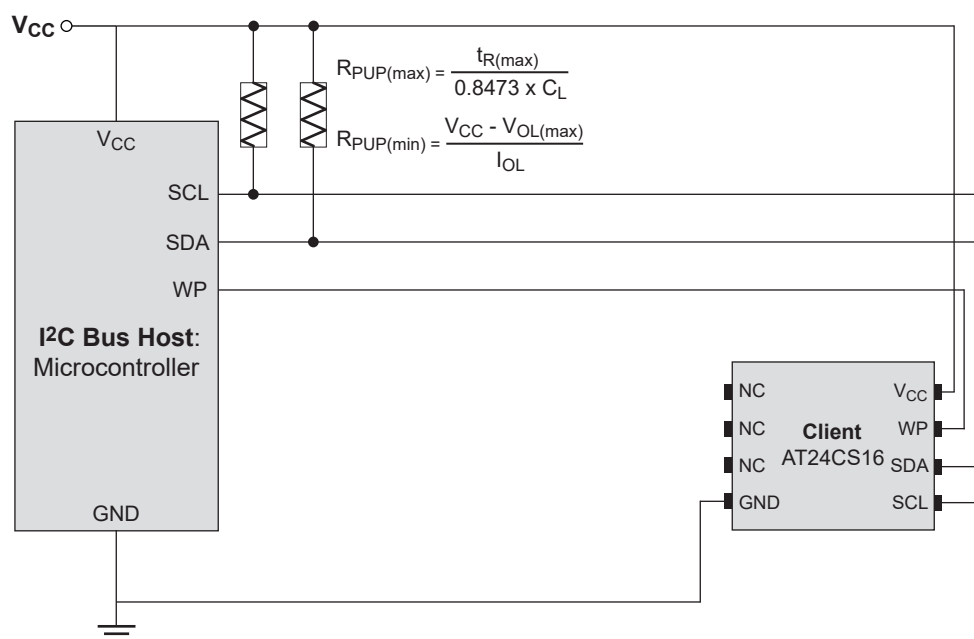

### 3.2. Block Diagram

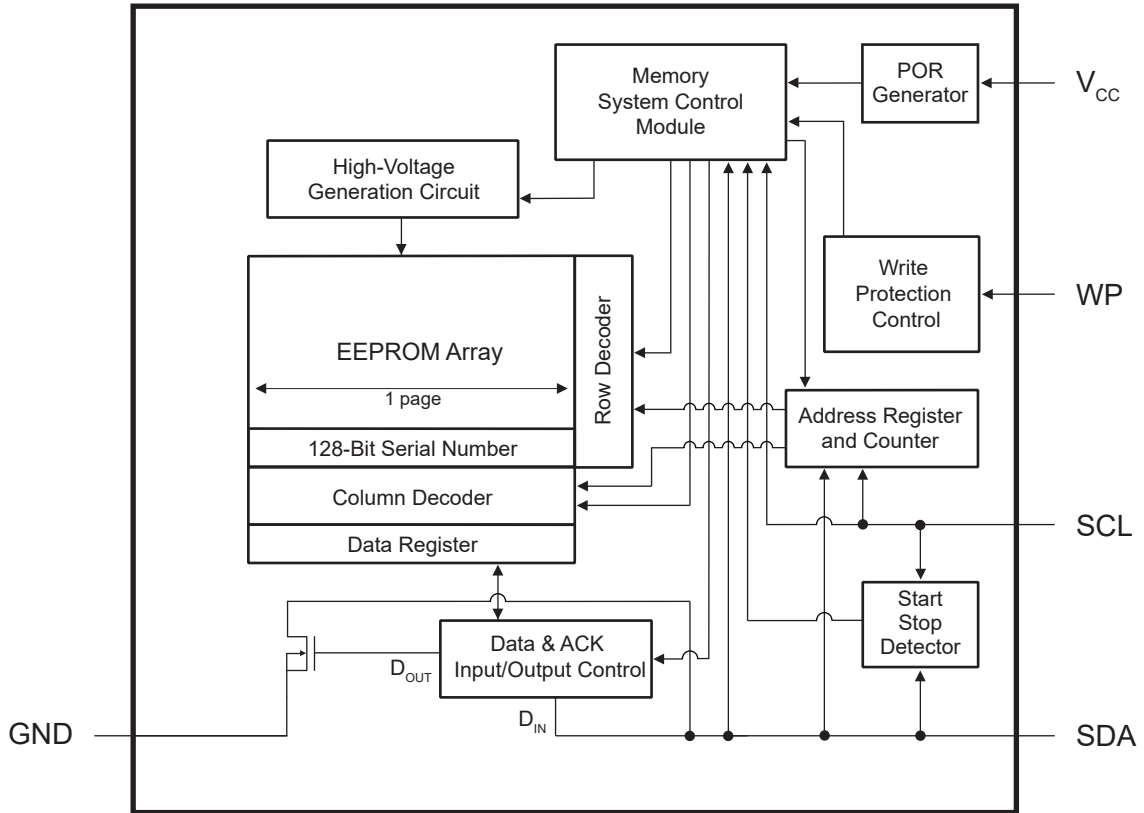

## 4. Electrical Characteristics

### 4.1. Absolute Maximum Ratings

Temperature under bias	-55°C to +125°C
Storage temperature	-65°C to +150°C
V <sub>CC</sub>	6.25V
Voltage on any pin with respect to ground	-1.0V to +7.0V
DC output current	5.0 mA
ESD protection	>4 kV

**Note:** Stresses above those listed under “Absolute Maximum Ratings” may cause permanent damage to the device. This is a stress rating only, and functional operation of the device at these or any other conditions above those indicated in the operation listings of this specification is not implied. Exposure to absolute maximum rating conditions for extended periods may affect device reliability.

### 4.2. DC and AC Operating Range

Table 4-1. DC and AC Operating Range

AT24CS16		
Operating Temperature (Case)	Industrial Temperature Range	-40°C to +85°C
V <sub>CC</sub> Power Supply	Low-Voltage Grade	1.7V to 5.5V

### 4.3. DC Characteristics

Table 4-2. DC Characteristics

Parameter	Symbol	Minimum	Maximum	Units	Test Conditions
Supply Voltage	V <sub>CC</sub>	1.7	5.5	V	
Supply Current	I <sub>CC1</sub>	—	1.0	mA	V <sub>CC</sub> = 5.0V, Read at 400 kHz
Supply Current	I <sub>CC2</sub>	—	3.0	mA	V <sub>CC</sub> = 5.0V, Write at 400 kHz
Standby Current	I <sub>SB</sub>	—	1.0	μA	V <sub>CC</sub> = 1.7V, V <sub>IN</sub> = V <sub>CC</sub> or GND
		—	6.0	μA	V <sub>CC</sub> = 5.5V, V <sub>IN</sub> = V <sub>CC</sub> or GND
Input Leakage Current	I <sub>LI</sub>	—	3.0	μA	V <sub>IN</sub> = V <sub>CC</sub> or GND
Output Leakage Current	I <sub>LO</sub>	—	3.0	μA	V <sub>OUT</sub> = V <sub>CC</sub> or GND
Input Low Level	V <sub>IL</sub>	-0.6	V <sub>CC</sub> × 0.3	V	Note 1
Input High Level	V <sub>IH</sub>	V <sub>CC</sub> × 0.7	V <sub>CC</sub> + 0.5	V	Note 1
Output Low Level	V <sub>OL1</sub>	—	0.2	V	V <sub>CC</sub> = 1.7V, I <sub>OL</sub> = 0.15 mA
Output Low Level	V <sub>OL2</sub>	—	0.4	V	V <sub>CC</sub> = 3.0V, I <sub>OL</sub> = 2.1 mA

**Note:**

1. This parameter is characterized but is not 100% tested in production.

## 4.4. AC Characteristics

Table 4-3. AC Characteristics<sup>(1)</sup>

Parameter	Symbol	Fast Mode		Fast Mode Plus		Units
		$V_{CC} = 1.7V \text{ to } 5.5V$		$V_{CC} = 1.7V \text{ to } 5.5V$		
		Min.	Max.	Min.	Max.	
Clock Frequency, SCL	$f_{SCL}$	—	400	—	1000	kHz
Clock Pulse Width Low	$t_{LOW}$	1200	—	500	—	ns
Clock Pulse Width High	$t_{HIGH}$	600	—	400	—	ns
Input Filter Spike Suppression	$t_I$	—	100	—	50	ns
Clock Low to Data Out Valid	$t_{AA}$	100	900	50	450	ns
Bus Free Time between Stop and Start	$t_{BUF}$	1300	—	500	—	ns
Start Hold Time	$t_{HD,STA}$	600	—	250	—	ns
Start Set-Up Time	$t_{SU,STA}$	600	—	250	—	ns
Data In Hold Time	$t_{HD,DAT}$	0	—	0	—	ns
Data In Set-Up Time	$t_{SU,DAT}$	100	—	100	—	ns
Inputs Rise Time <sup>(2)</sup>	$t_R$	—	300	—	300	ns
Inputs Fall Time <sup>(2)</sup>	$t_F$	—	300	—	100	ns
Stop Set-Up Time	$t_{SU,STO}$	600	—	250	—	ns
Data Out Hold Time	$t_{DH}$	50	—	50	—	ns
Write Cycle Time	$t_{WR}$	—	5	—	5	ms

### Notes:

- AC measurement conditions:
  - $C_L$ : 100 pF
  - $R_{PUP}$  (SDA bus line pull-up resistor to  $V_{CC}$ ): 1.3 k $\Omega$  (1000 kHz), 4 k $\Omega$  (400 kHz), 10 k $\Omega$  (100 kHz)
  - Input rise and fall times:  $\leq 50$  ns
  - Input and output timing reference voltages:  $0.5 \times V_{CC}$
- This parameter is characterized but is not 100% tested in production.

Figure 4-1. Bus Timing

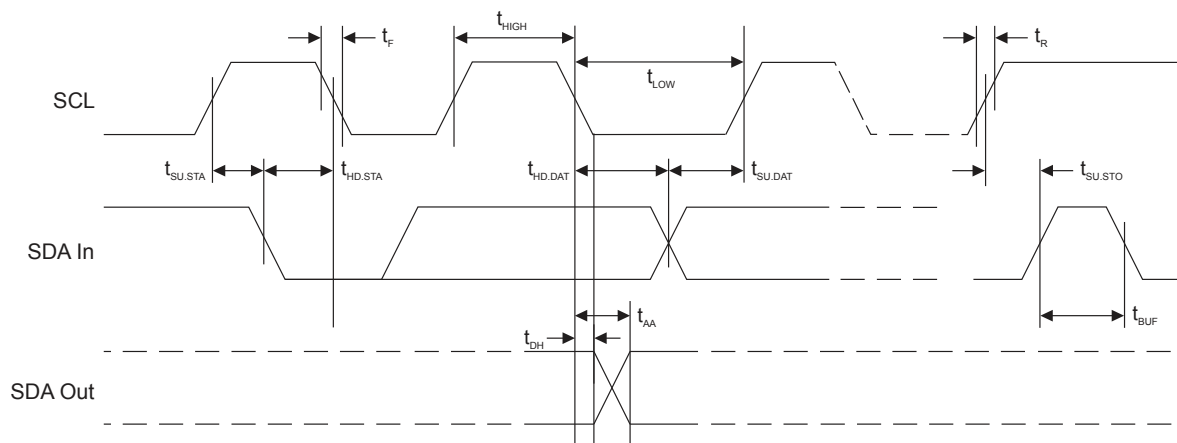

## 4.5. Electrical Specifications

### 4.5.1. Power-Up Requirements and Reset Behavior

During a power-up sequence, the  $V_{CC}$  supplied to the AT24CS16 should monotonically rise from GND to the minimum  $V_{CC}$  level (as specified in Table 4-1), with a slew rate no faster than 0.1 V/ $\mu$ s.

#### 4.5.1.1. Device Reset

To prevent inadvertent write operations or any other spurious events from occurring during a power-up sequence, the AT24CS16 includes a Power-on Reset (POR) circuit. Upon power-up, the device will not respond to any commands until the  $V_{CC}$  level crosses the internal voltage threshold ( $V_{POR}$ ) that brings the device out of Reset and into Standby mode.

The system designer must ensure the instructions are not sent to the device until the  $V_{CC}$  supply has reached a stable value greater than or equal to the minimum  $V_{CC}$  level. Additionally, once the  $V_{CC}$  is greater than or equal to the minimum  $V_{CC}$  level, the bus host must wait at least  $t_{PUP}$  before sending the first command to the device. See Table 4-4 for the values associated with these power-up parameters.

**Table 4-4.** Power-up Conditions<sup>(1)</sup>

Symbol	Parameter	Min.	Max.	Units
$t_{PUP}$	Time required after $V_{CC}$ is stable before the device can accept commands	100	—	$\mu$ s
$V_{POR}$	Power-on Reset Threshold Voltage	—	1.5	V
$t_{POFF}$	Minimum time at $V_{CC} = 0V$ between power cycles	500	—	ms

**Note:**

1. These parameters are characterized but they are not 100% tested in production.

If an event occurs in the system where the  $V_{CC}$  level supplied to the AT24CS16 drops below the maximum  $V_{POR}$  level specified, it is recommended that a full power cycle sequence be performed by first driving the  $V_{CC}$  pin to GND, waiting at least the minimum  $t_{POFF}$  time, and then performing a new power-up sequence in compliance with the requirements defined in this section.

### 4.5.2. Pin Capacitance

**Table 4-5.** Pin Capacitance<sup>(1)</sup>

Symbol	Test Condition	Max.	Units	Conditions
$C_{I/O}$	Input/Output Capacitance (SDA)	8	pF	$V_{I/O} = 0V$
$C_{IN}$	Input Capacitance (SCL)	6	pF	$V_{IN} = 0V$

**Note:**

1. This parameter is characterized but is not 100% tested in production.

### 4.5.3. EEPROM Cell Performance Characteristics

**Table 4-6.** EEPROM Cell Performance Characteristics

Operation	Test Condition	Min.	Max.	Units
Write Endurance <sup>(1)</sup>	$T_A = +25^\circ C$ , $V_{CC} = 5.5V$ , Page Write mode	1,000,000	—	Write Cycles
Data Retention <sup>(1)</sup>	$T_A = +55^\circ C$	100	—	Years

**Note:**

1. Performance is determined through characterization and the qualification process.

## 5. Device Operation and Communication

The AT24CS16 operates as a client device and utilizes a simple I<sup>2</sup>C-compatible Two-Wire digital serial interface to communicate with a host controller, commonly referred to as the bus host. The host initiates and controls all read and write operations to the client devices on the serial bus, and both the host and the client devices can transmit and receive data on the bus.

The serial interface consists of two signal lines: Serial Clock (SCL) and Serial Data (SDA).

The SCL pin is used to receive the clock signal from the host, while the bidirectional SDA pin is used to receive command and data information from the host as well as to send data back to the host. Data are always latched into the AT24CS16 on the rising edge of SCL and always output from the device on the falling edge of SCL. Both the SCL and SDA pins incorporate integrated spike suppression filters and Schmitt Triggers to minimize the effects of input spikes and bus noise.

All command and data information is transferred with the Most Significant bit (MSb) first. During bus communication, one data bit is transmitted every clock cycle, and after eight bits (one byte) of data have been transferred, the receiving device must respond with either an Acknowledge (ACK) or a No-Acknowledge (NACK) response bit during a ninth clock cycle (ACK/NACK clock cycle) generated by the host. Therefore, nine clock cycles are required for every one byte of data transferred. There are no unused clock cycles during any read or write operation; thus, there must not be any interruptions or breaks in the data stream during each data byte transfer and ACK or NACK clock cycle.

During data transfers, data on the SDA pin must change only while SCL is low, and the data must remain stable while SCL is high. If data on the SDA pin changes while SCL is high, then either a Start or a Stop condition will occur. Start and Stop conditions are used to initiate and terminate all serial bus communication between the host and the client devices. The number of data bytes transferred between a Start and a Stop condition is not limited and is determined by the host. For the serial bus to be idle, both the SCL and SDA pins must be in the logic high state simultaneously.

### 5.1. Clock and Data Transition Requirements

The SDA pin is an open-drain terminal and therefore must be pulled high with an external pull-up resistor. SCL is an input pin that can either be driven high or pulled high using an external pull-up resistor. Data on the SDA pin may change only during SCL low time periods. Data changes during SCL high periods will indicate a Start or Stop condition as defined below. The relationship of the AC timing parameters with respect to SCL and SDA for the AT24CS16 are shown in the timing waveform in [Figure 4-1](#). The AC timing characteristics and specifications are outlined in [AC Characteristics](#).

### 5.2. Start and Stop Conditions

#### 5.2.1. Start Condition

A Start condition occurs when there is a high-to-low transition on the SDA pin while the SCL pin is at a stable logic '1' state, which will bring the device out of Standby mode. The host initiates any data transfer sequence with a Start condition; thus, every command must commence with this condition. The device continuously monitors the SDA and SCL pins for a Start condition and will only respond when one is detected. Refer to [Figure 5-1](#) for more details.

#### 5.2.2. Stop Condition

A Stop condition occurs when there is a low-to-high transition on the SDA pin while the SCL pin is stable in the logic '1' state.

The host can use the Stop condition to end a data transfer sequence with the AT24CS16, which will subsequently return to Standby mode. The host can also utilize a repeated Start condition instead of a Stop condition to end the current data transfer if the host will perform another operation. Refer to [Figure 5-1](#) for more details.

### 5.3. Acknowledge and No-Acknowledge

After each byte of data is received, the receiving device must confirm with the transmitting device that it has successfully received the data byte by responding with an Acknowledge (ACK). An ACK occurs when the transmitting device releases the SDA line at the falling edge of the eighth clock cycle, followed by the receiving device responding with a logic '0' throughout the ninth clock cycle's high period.

When the AT24CS16 transmits data to the host, the host can indicate that it has finished receiving data and wants to end the operation by sending a logic '1' response to the AT24CS16 instead of an ACK response during the ninth clock cycle. This is known as a No-Acknowledge (NACK) and is accomplished when the host sends a logic '1' during the ninth clock cycle, at which point the AT24CS16 will release the SDA line so the host can then generate a Stop condition.

The transmitting device, which can be either the bus host or the Serial EEPROM, must release the SDA line at the falling edge of the eighth clock cycle to allow the receiving device to drive the SDA line to a logic '0' to ACK the previous 8-bit word. The receiving device must release the SDA line at the end of the ninth clock cycle to allow the transmitter to continue sending new data. A timing diagram is provided in [Figure 5-1](#) to better illustrate these requirements.

**Figure 5-1.** Start Condition, Data Transitions, Stop Condition and Acknowledge

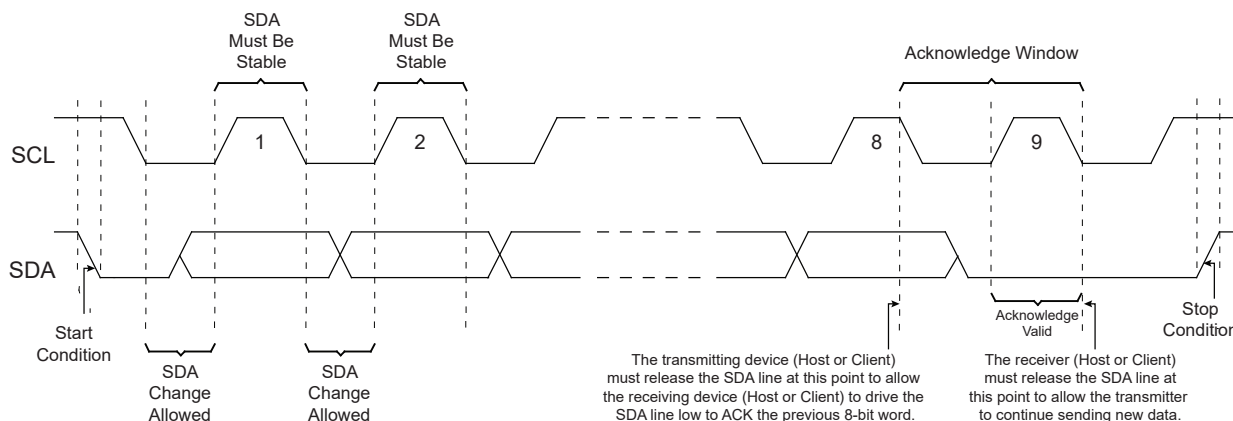

### 5.4. Standby Mode

The AT24CS16 features a low-power Standby mode that is enabled when any one of the following occurs:

- A valid power-up sequence is performed (see [Power-Up Requirements and Reset Behavior](#)).
- A Stop condition at the end of a valid I<sup>2</sup>C transaction is received by the device unless it initiates an internal write cycle (see [Write Operations](#)).
- An internal write cycle is completed (see [Write Operations](#)).

### 5.5. Software Reset

After an interruption in protocol, power loss or system Reset, any Two-Wire device can be protocol reset by clocking SCL until SDA is released by the EEPROM and goes high. The number of clock cycles until SDA is released by the EEPROM will vary. The software Reset sequence should not take more than nine dummy clock cycles. Once the software Reset sequence is complete, a new protocol can be sent to the device by sending a Start condition followed by the protocol. Refer to [Figure 5-2](#) for an illustration.

Figure 5-2. Software Reset

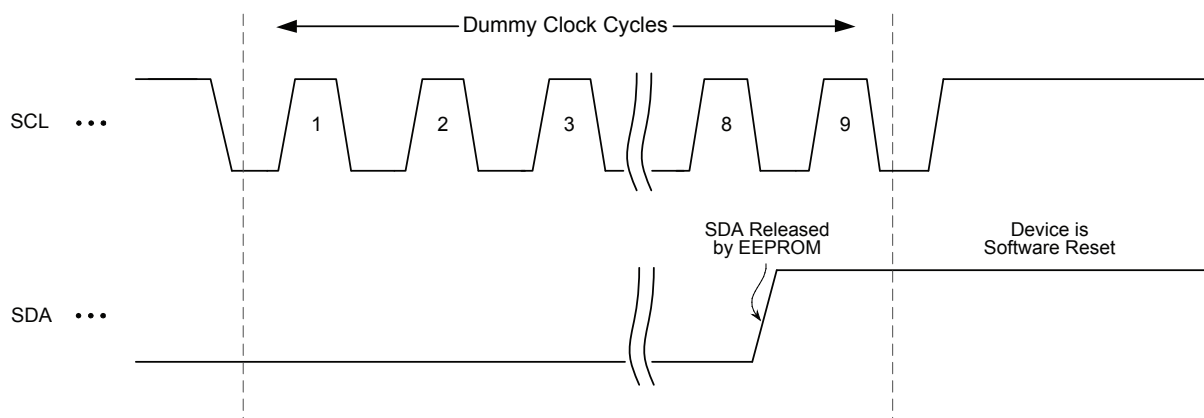

In the event that the device is still non-responsive or remains active on the SDA bus, a power cycle must be used to reset the device (see [Power-Up Requirements and Reset Behavior](#)).

## 6. Memory Organization

The AT24CS16 is internally organized as 128 pages of 16 bytes each.

### 6.1. Device Addressing

Accessing the device requires an 8-bit device address byte following a Start condition to enable the device for a read or write operation.

The Most Significant four bits of the device address byte are referred to as the device type identifier. The device type identifier '1010' (Ah) is required in bits 7 through 4 of the device address byte (see [Table 6-1](#)).

The AT24CS16 utilizes a separate memory block containing a factory-programmed 128-bit serial number. Access to this memory location is similar to the EEPROM region with the exception that the device type identifier is set to '1011' (Bh) in bits 7 through 4 of the device address byte (see [Table 6-1](#)).

Following the 4-bit device type identifier in the bit 3, bit 2 and bit 1 position of the device address byte are bits A10, A9 and A8, which are the three Most Significant bits of the memory array word address.

The eighth bit (bit 0) of the device address byte is the Read/Write Select bit. A read operation is initiated if this bit is high and a write operation is initiated if this bit is low.

Upon the successful comparison of the device address byte, the AT24CS16 will return an ACK. If a valid comparison is not made, the device will NACK.

**Table 6-1. Device Address Byte**

Package	Device Type Identifier				Most Significant Bits of the Word Address			R/W Select
	Bit 7	Bit 6	Bit 5	Bit 4	Bit 3	Bit 2	Bit 1	Bit 0
EEPROM	1	0	1	0	A10	A9	A8	R/ $\overline{W}$
Serial Number	1	0	1	1	0	0	0	R/ $\overline{W}$

For all operations except the current address read, a word address byte must be transmitted to the device immediately following the device address byte. The word address byte consists of the remaining eight bits of the 11-bit memory array word address and is used to specify which byte location in the EEPROM to start reading or writing. Refer to [Table 6-2](#) to review these bit positions.

**Table 6-2. Word Address Byte**

Access Area	Bit 7	Bit 6	Bit 5	Bit 4	Bit 3	Bit 2	Bit 1	Bit 0
EEPROM	A7	A6	A5	A4	A3	A2	A1	A0
Serial Number	1	0	X	X	X	X	X	X

## 7. Write Operations

All write operations for the AT24CS16 begin with the host sending a Start condition, followed by a device address byte with the  $R/\overline{W}$  bit set to logic '0', and then by the word address byte. The data value(s) to be written to the device immediately follow the word address byte.

### 7.1. Byte Write

The AT24CS16 supports the writing of a single 8-bit byte. Selecting a data word in the AT24CS16 requires an 11-bit word address.

Upon receipt of the proper device address and word address bytes, the EEPROM will send an Acknowledge. The device will then be ready to receive the 8-bit data word. After receiving the 8-bit data word, the EEPROM will respond with an ACK. The addressing device, such as a bus host, must then terminate the write operation with a Stop condition. At this point, the EEPROM will enter an internally self-timed write cycle, which will be completed within  $t_{WR}$ , while the data word is being programmed into the nonvolatile EEPROM. All inputs are disabled during this write cycle, and the EEPROM will not respond until the write is complete.

Figure 7-1. Byte Write

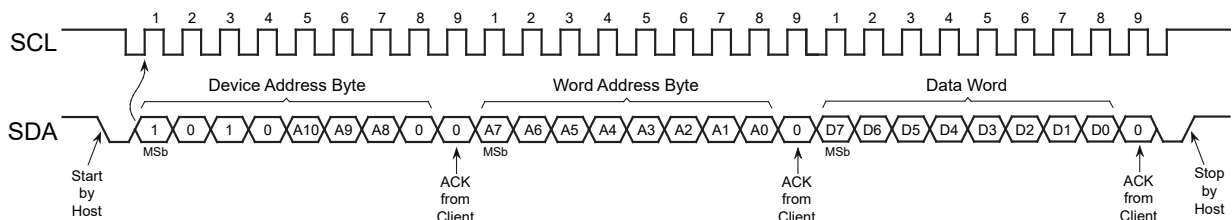

### 7.2. Page Write

A page write operation allows up to 16 bytes to be written in a single write cycle, provided that all bytes are in the same row of the memory array (where address bits A10 through A4 are identical). Partial page writes of fewer than 16 bytes are also allowed.

A page write is initiated the same way as a byte write, but the bus host does not send a Stop condition after the first data word is clocked in. Instead, after the EEPROM acknowledges receipt of the first data word, the bus host can transmit up to fifteen additional data words. The EEPROM will respond with an ACK after each data word is received. Once all data to be written have been sent to the device, the bus host must issue a Stop condition (see Figure 7-2), at which point the internally self-timed write cycle will begin.

The lower four bits of the word address are internally incremented following the receipt of each data word. The higher-order address bits are not incremented and retain the memory page row location. Page write operations are limited to writing bytes within a single physical page, regardless of the number of bytes being written. When the incremented word address reaches the page boundary, the address counter will roll over to the beginning of the same page. Nevertheless, creating a rollover event should be avoided as previously loaded data in the page could become unintentionally altered.

Figure 7-2. Page Write

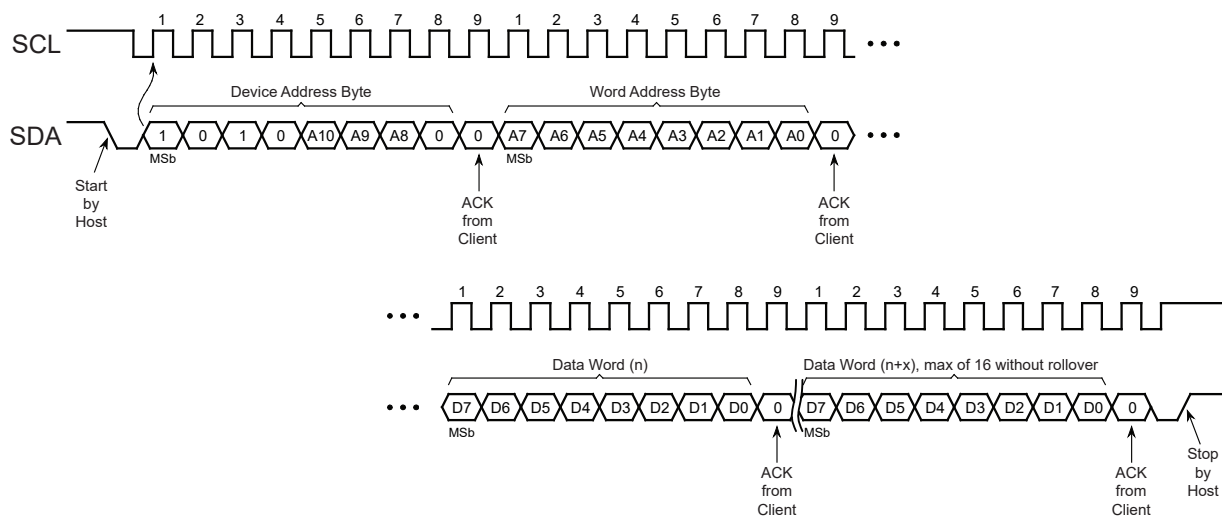

### 7.3. Acknowledge Polling

An Acknowledge Polling routine can be implemented to optimize time-sensitive applications that aim to avoid waiting for the fixed maximum write cycle time ( $t_{WR}$ ). This method allows the application to promptly determine when the Serial EEPROM write cycle has completed so a subsequent operation can be started.

Once the internally self-timed write cycle has started, an Acknowledge Polling routine can be initiated. This involves repeatedly sending a Start condition followed by a valid device address byte with the  $R/\bar{W}$  bit set to logic '0'. The device will not respond with an ACK while the write cycle is ongoing. Once the internal write cycle has completed, the EEPROM will respond with an ACK, allowing a new read or write operation to be immediately initiated. A flowchart has been included in [Figure 7-3](#) to better illustrate this technique.

Figure 7-3. Acknowledge Polling Flowchart

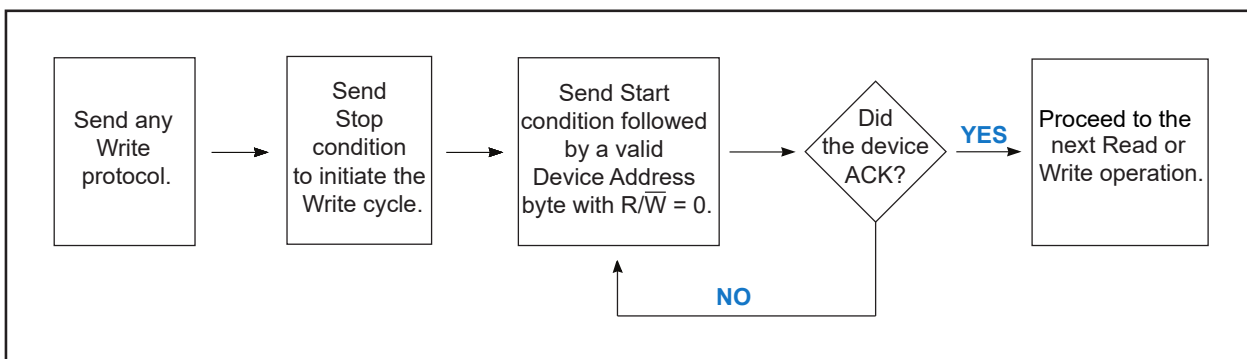

### 7.4. Write Cycle Timing

The length of the self-timed write cycle ( $t_{WR}$ ) is defined as the amount of time from the Stop condition, which begins the internal write cycle, to the Start condition of the first device address byte sent to the AT24CS16, to which it subsequently responds with an ACK. [Figure 7-4](#) shows this measurement. During the internally self-timed write cycle, any attempts to read from or write to the memory array will not be processed.

Figure 7-4. Write Cycle Timing

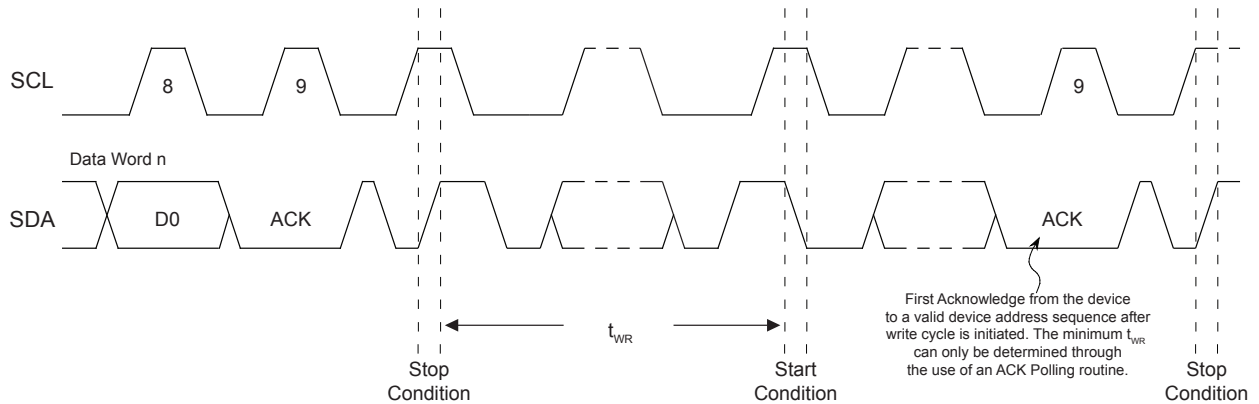

## 7.5. Write Protection

The AT24CS16 utilizes a hardware data protection scheme that allows the user to write-protect the entire memory contents when the WP pin is at  $V_{CC}$  (or a valid  $V_{IH}$ ). No write protection will be set if the WP pin is at GND or left floating.

Table 7-1. AT24CS16 Write-Protect Behavior

WP Pin Voltage	Part of the Array Protected
$V_{CC}$	Full Array
GND	None — Write Protection Not Enabled

The status of the WP pin is sampled at the Stop condition for every byte write or page write operation prior to the start of an internally self-timed write cycle. Changing the WP pin state after the Stop condition has been sent will not alter or interrupt the execution of the write cycle.

If an attempt is made to write to the device while the WP pin has been asserted, the device will acknowledge the device address, word address and data bytes. However, no write cycle will occur when the Stop condition is issued. The device will immediately be ready to accept a new read or write command.

## 8. Read Operations

Read operations are initiated the same way as write operations with the exception that the Read/Write Select bit in the device address byte must be a logic '1'. There are four read operations:

- Current Address Read
- Random Address Read
- Sequential Read
- Serial Number Read

**Note:** The AT24CS16 contains a single Address Pointer register, which is shared by both the EEPROM and the serial number. As such, when changing from one region to the other, the first read operation in the new region should begin with a dummy write sequence (i.e., a random read operation with the new region's device address and word address bytes) in order to ensure the Address Pointer is set to a known value. See [Serial Number Read](#) for additional requirements on the serial number read.

### 8.1. Current Address Read

The internal data word address counter maintains the last address accessed during the last read or write operation, incremented by one. This address remains valid between operations as long as the  $V_{CC}$  is maintained to the part. The address rollover during a read is from the last byte of the last page to the first byte of the first page of the memory.

A current address read operation outputs data according to the location of the internal data word address counter. This is initiated with a Start condition, followed by a valid device address byte with the R/W bit set to logic '1'. The device will ACK this sequence, and the current address data word is serially clocked out on the SDA line. All types of read operations will terminate if the bus host does not respond with an ACK (it NACKs) during the ninth clock cycle. After the NACK response, the host may send a Stop condition to complete the protocol, or it can send a Start condition to begin the next sequence.

While the three Most Significant bits of the data word address (A10, A9 and A8) are embedded in the Device Address byte, they do not take precedence over the existing values of the A10, A9 and A8 bits in the internal address counter during a Current Address Read and are therefore represented as "don't care" bits, as shown in [Figure 8-1](#).

**Figure 8-1.** Current Address Read

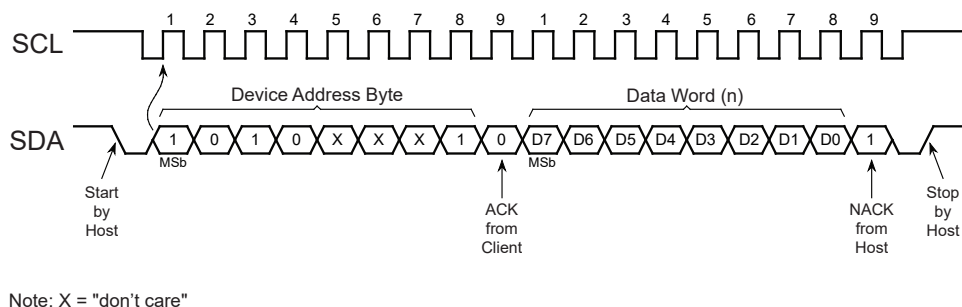

### 8.2. Random Read

A random read begins in the same way as a byte write operation does to load in a new data word address. This is known as a "dummy write" sequence; however, the data byte and the Stop condition of the byte write must be omitted to prevent the part from entering an internal write cycle. Once the device address and word address are clocked in and acknowledged by the EEPROM, the bus host must generate another Start condition. The bus host now initiates a current address read by

sending a Start condition, followed by a valid device address byte with the  $R/\bar{W}$  bit set to logic '1'. In this second device address byte, the bit positions usually reserved for the Most Significant bits of the word address (bits 3, 2 and 1) are “don't care” bits since the address that will be read from is determined only by what was sent in the dummy write portion of the sequence. The EEPROM will ACK the device address and serially clock out the data word on the SDA line. All types of read operations will be terminated if the bus host does not respond with an ACK (it NACKs) during the ninth clock cycle. After the NACK response, the host may send a Stop condition to complete the protocol, or it can send a Start condition to begin the next sequence.

**Figure 8-2. Random Read**

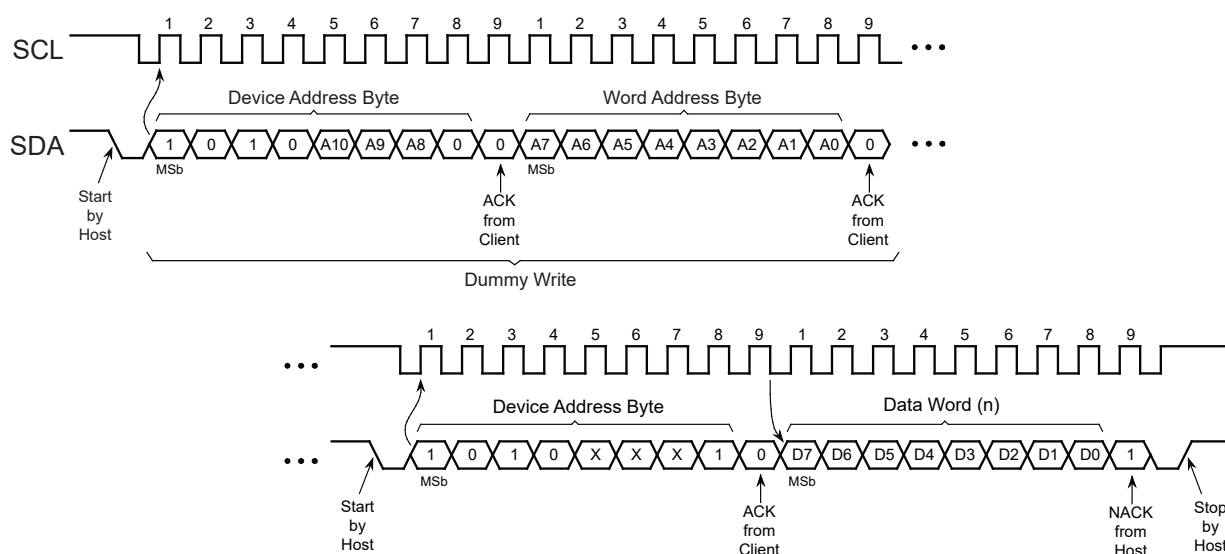

### 8.3. Sequential Read

Sequential Reads are initiated by either a Current Address Read or a Random Read, as previously described. As such, the A10, A9 and A8 bits sent in the Device Address byte are “don't care” values since they do not affect the values in the address pointer. As long as the EEPROM receives an ACK, it will continue to increment the word address and serially clock out sequential data words. When the maximum memory address is reached, the data word address will roll over, and the sequential read will continue from the beginning of the memory array. All types of read operations will be terminated if the bus host does not respond with an ACK (it NACKs) during the ninth clock cycle. Following the NACK response, the host may send a Stop condition to complete the protocol or a Start condition to initiate the next sequence.

Figure 8-3. Sequential Read

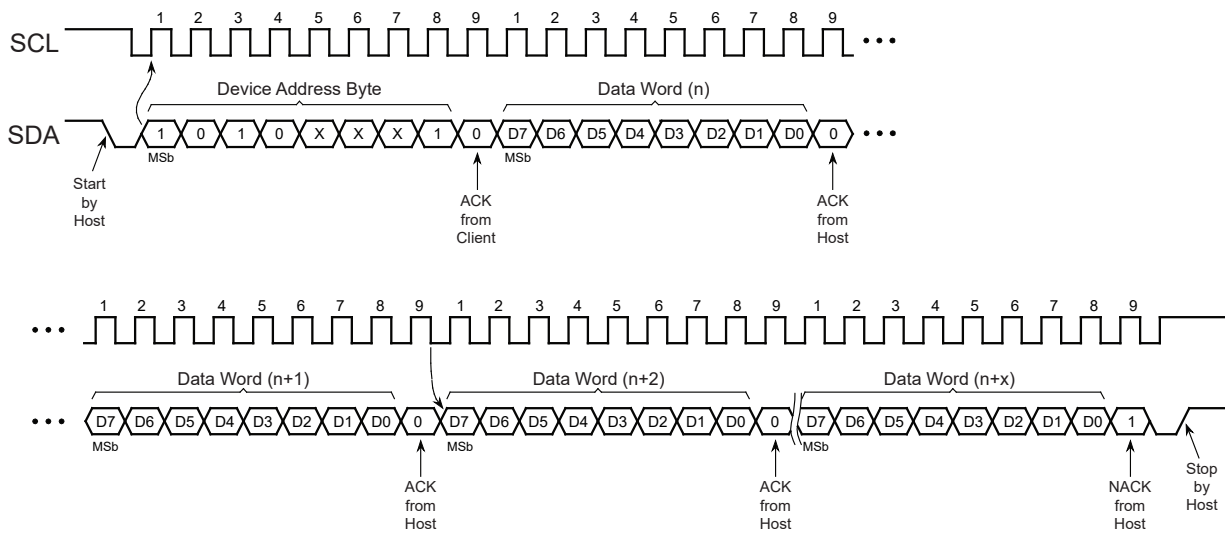

Note: X = "don't care"

## 8.4. Serial Number Read

Reading the serial number is similar to the sequential read sequence but requires use of the specific Device Address and Word Address bytes as specified in Table 6-1 and Table 6-2.

**Note:** The entire 128-bit value must be read from the starting address of the serial number block to ensure a unique number.

Since the Address Pointer of the device is shared between the regular EEPROM array and the serial number block, a dummy write sequence, as part of a random read or sequential read protocol, should be performed to ensure the Address Pointer is set to a known value. Reading the serial number from a location other than the first address of the block will not result in a unique serial number.

Additionally, the word address contains a '10' sequence in bits A7 and A6 of the word address, regardless of the intended address as depicted in Table 6-2. If a word address other than '10' is used, the device will output undefined data.

**Note:** If the application needs to read the first byte of the serial number, the word address input should be 80h.

When the end of the 128-bit serial number is reached (16 bytes of data), the data word address will roll over back to the beginning of the 128-bit serial number. The serial number read operation is terminated when the bus host does not respond with an ACK (it NACKs) during the ninth clock cycle. Following the NACK response, the host may send a Stop condition to complete the protocol, or it can send a Start condition to begin the next sequence (see Figure 8-4).

Figure 8-4. Serial Number Read

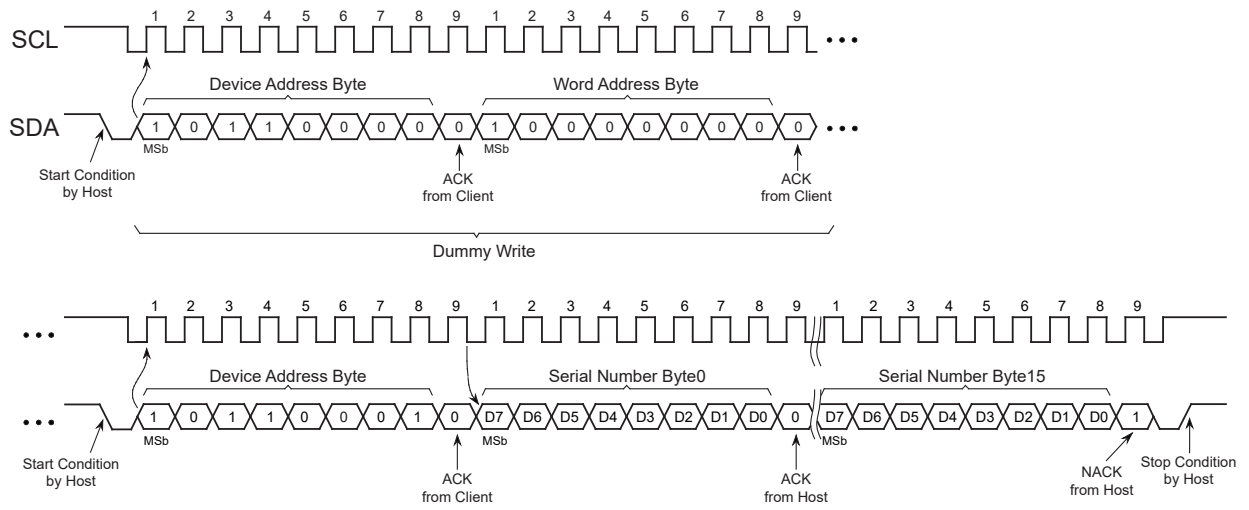

## 9. Device Default Condition from Microchip

The AT24CS16 is delivered with the EEPROM array set to logic '1', resulting in FFh data in all locations.

## 10. Packaging Information

### 10.1. Package Marking Information

**AT24CS16: Package Marking Information**

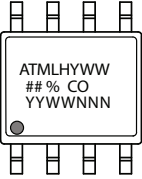
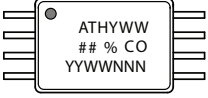
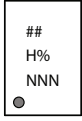
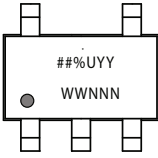
<p><b>8-Lead SOIC</b></p> 	<p><b>8-Lead TSSOP</b></p> 
<p><b>8-Pad UDFN</b></p> <p>2.0 x 3.0 mm Body</p> 	<p><b>5-Lead SOT23</b></p> 

Note 1: ● designates pin 1  
Note 2: Package drawing are not to scale

<b>Catalog Number Truncation</b>		
AT24CS16		Truncation Code ##: NA
<b>Date Codes</b>		<b>Voltages</b>
Y = Year Code (last digit of calendar year) YY = Year Code (last 2 digits of calendar year) WW = Week Code (week of January 1 is week '01')		% = Minimum Voltage M: 1.7V min
<b>Country of Origin</b>	<b>Device Grade</b>	<b>Atmel Truncation</b>
CO = Country of Origin	H or U: Industrial Grade	AT: Atmel ATM: Atmel ATML: Atmel
<b>Trace Code</b>		
NNN = Alphanumeric Trace Code (2 Characters for Small Packages)		

### 8-Lead Plastic Small Outline (SN) - Narrow, 3.90 mm (.150 In.) Body [SOIC]

**Note:** For the most current package drawings, please see the Microchip Packaging Specification located at <http://www.microchip.com/packaging>

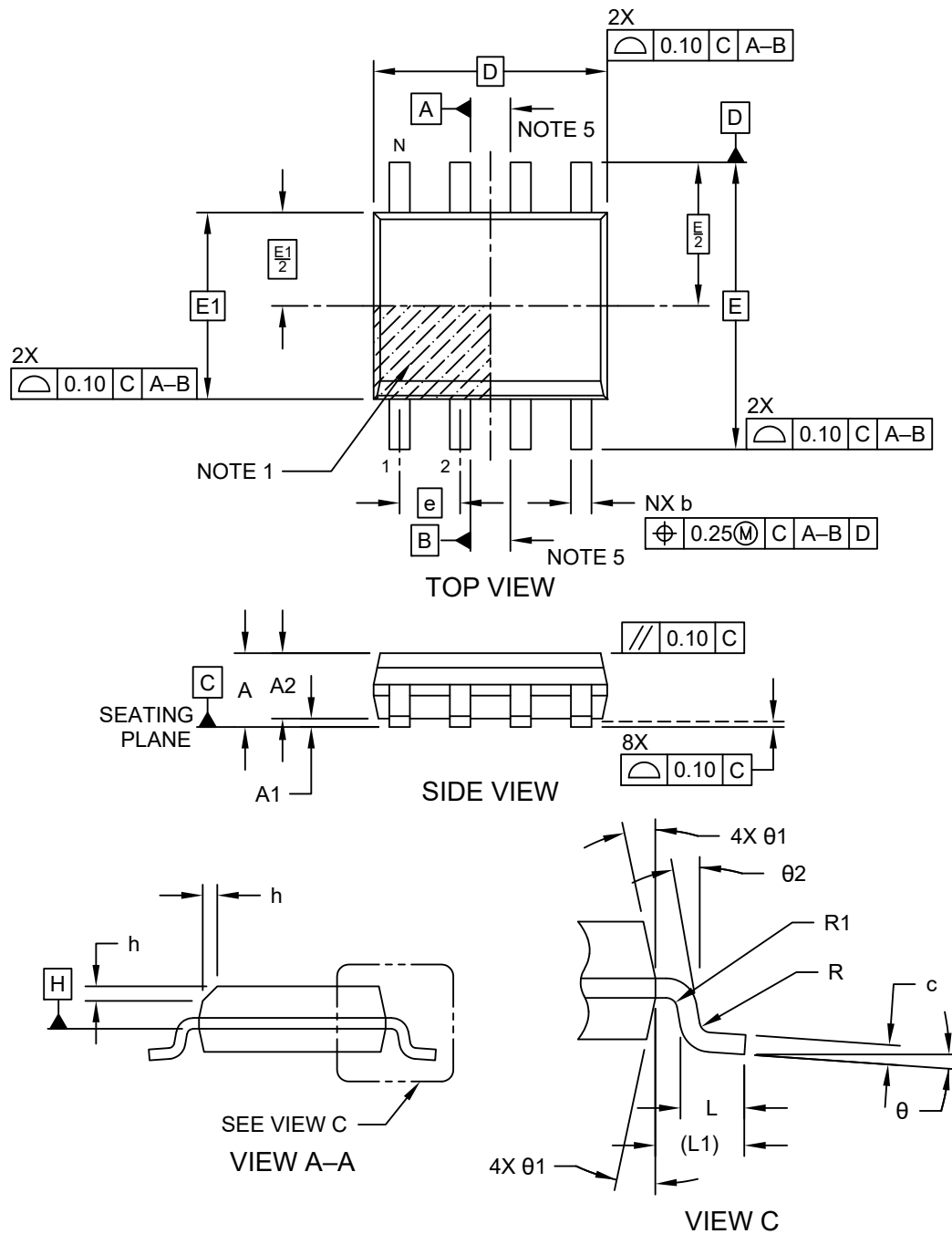

Microchip Technology Drawing No. C04-057-SN Rev K Sheet 1 of 2

## 8-Lead Plastic Small Outline (SN) - Narrow, 3.90 mm (.150 In.) Body [SOIC]

**Note:** For the most current package drawings, please see the Microchip Packaging Specification located at <http://www.microchip.com/packaging>

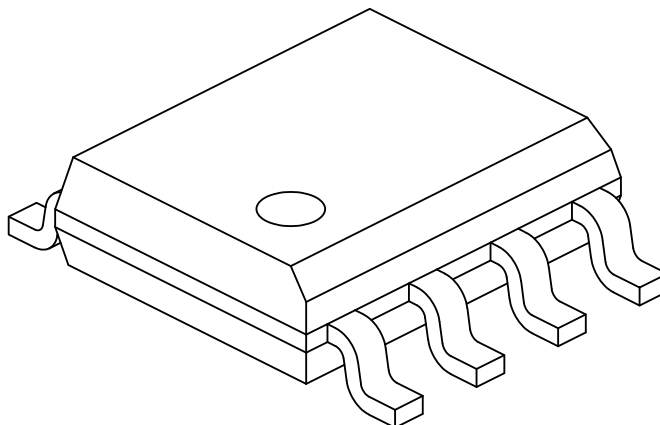

Dimension Limits	Units	MILLIMETERS		
		MIN	NOM	MAX
Number of Pins	N	8		
Pitch	e	1.27 BSC		
Overall Height	A	–	–	1.75
Molded Package Thickness	A2	1.25	–	–
Standoff §	A1	0.10	–	0.25
Overall Width	E	6.00 BSC		
Molded Package Width	E1	3.90 BSC		
Overall Length	D	4.90 BSC		
Chamfer (Optional)	h	0.25	–	0.50
Foot Length	L	0.40	–	1.27
Footprint	L1	1.04 REF		
Lead Thickness	c	0.17	–	0.25
Lead Width	b	0.31	–	0.51
Lead Bend Radius	R	0.07	–	–
Lead Bend Radius	R1	0.07	–	–
Foot Angle	θ	0°	–	8°
Mold Draft Angle	θ1	5°	–	15°
Lead Angle	θ2	0°	–	–

**Notes:**

1. Pin 1 visual index feature may vary, but must be located within the hatched area.
2. § Significant Characteristic
3. Dimensions D and E1 do not include mold flash or protrusions. Mold flash or protrusions shall not exceed 0.15mm per side.
4. Dimensioning and tolerancing per ASME Y14.5M
  - BSC: Basic Dimension. Theoretically exact value shown without tolerances.
  - REF: Reference Dimension, usually without tolerance, for information purposes only.
5. Datums A & B to be determined at Datum H.

Microchip Technology Drawing No. C04-057-SN Rev K Sheet 2 of 2

### 8-Lead Plastic Small Outline (SN) - Narrow, 3.90 mm (.150 In.) Body [SOIC]

**Note:** For the most current package drawings, please see the Microchip Packaging Specification located at <http://www.microchip.com/packaging>

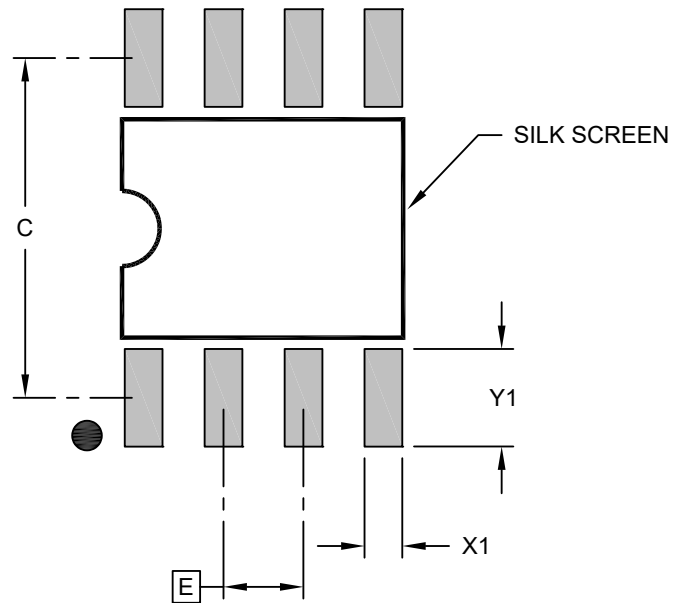

RECOMMENDED LAND PATTERN

		Units	MILLIMETERS		
Dimension Limits			MIN	NOM	MAX
Contact Pitch	E		1.27 BSC		
Contact Pad Spacing	C			5.40	
Contact Pad Width (X8)	X1				0.60
Contact Pad Length (X8)	Y1				1.55

Notes:

1. Dimensioning and tolerancing per ASME Y14.5M  
BSC: Basic Dimension. Theoretically exact value shown without tolerances.

Microchip Technology Drawing C04-2057-SN Rev K

### 8-Lead Plastic Thin Shrink Small Outline (ST) - 4.4 mm Body [TSSOP]

**Note:** For the most current package drawings, please see the Microchip Packaging Specification located at <http://www.microchip.com/packaging>

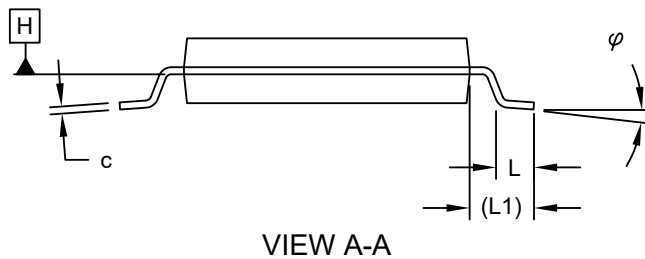
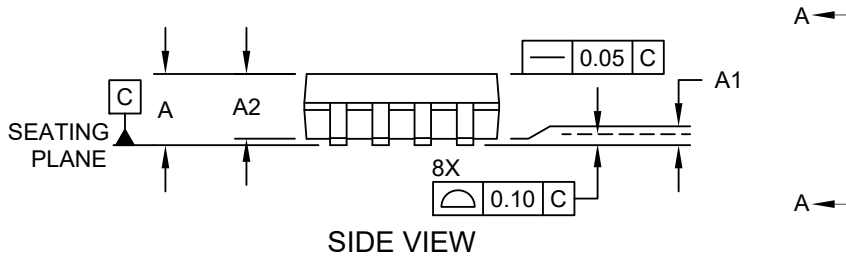
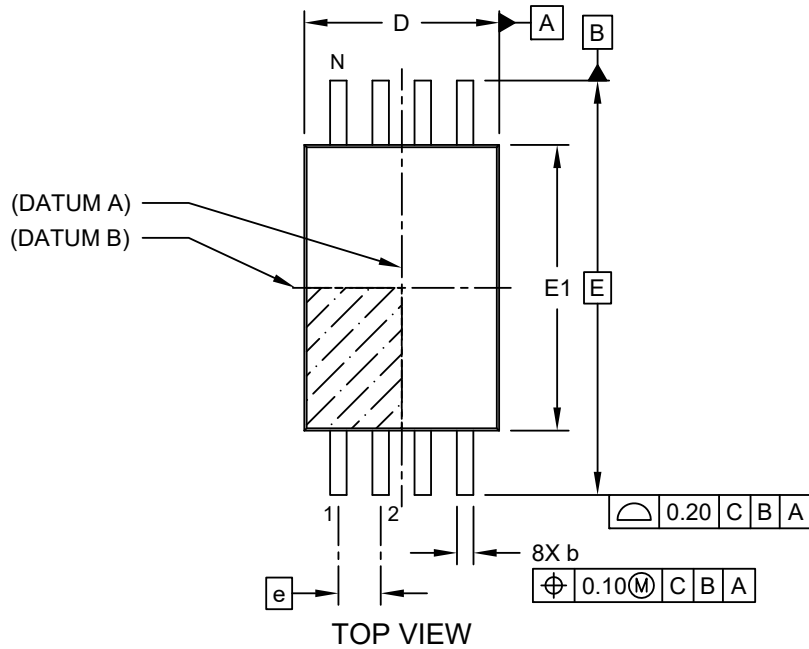

Microchip Technology Drawing C04-086 Rev C Sheet 1 of 2

## 8-Lead Plastic Thin Shrink Small Outline (ST) - 4.4 mm Body [TSSOP]

**Note:** For the most current package drawings, please see the Microchip Packaging Specification located at <http://www.microchip.com/packaging>

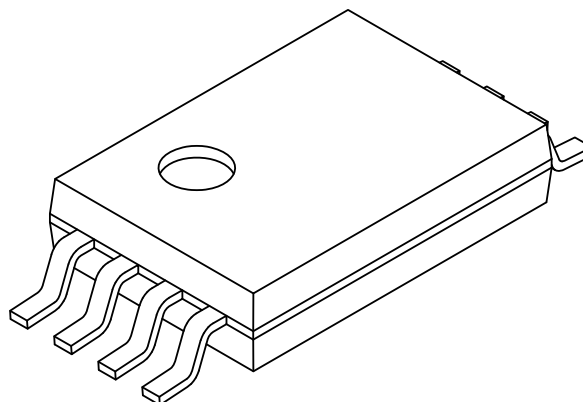

Dimension Limits	Units	MILLIMETERS		
		MIN	NOM	MAX
Number of Pins	N	8		
Pitch	e	0.65 BSC		
Overall Height	A	-	-	1.20
Molded Package Thickness	A2	0.80	1.00	1.05
Standoff	A1	0.05	-	-
Overall Width	E	6.40 BSC		
Molded Package Width	E1	4.30	4.40	4.50
Overall Length	D	2.90	3.00	3.10
Foot Length	L	0.45	0.60	0.75
Footprint	L1	1.00 REF		
Lead Thickness	c	0.09	-	0.25
Foot Angle	$\varphi$	0°	4°	8°
Lead Width	b	0.19	-	0.30

**Notes:**

- Pin 1 visual index feature may vary, but must be located within the hatched area.
- Dimensions D and E1 do not include mold flash or protrusions. Mold flash or protrusions shall not exceed 0.20mm per side.
- Dimensioning and tolerancing per ASME Y14.5M  
 BSC: Basic Dimension. Theoretically exact value shown without tolerances.  
 REF: Reference Dimension, usually without tolerance, for information purposes only.

Microchip Technology Drawing C04-086 Rev C Sheet 2 of 2

## 8-Lead Plastic Thin Shrink Small Outline (ST) - 4.4 mm Body [TSSOP]

**Note:** For the most current package drawings, please see the Microchip Packaging Specification located at <http://www.microchip.com/packaging>

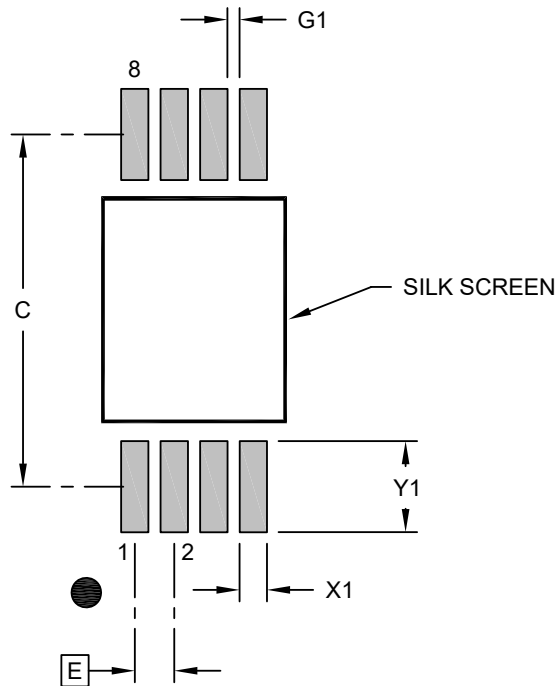

RECOMMENDED LAND PATTERN

Dimension Limits	Units	MILLIMETERS		
		MIN	NOM	MAX
Contact Pitch	E	0.65 BSC		
Contact Pad Spacing	C	5.80		
Contact Pad Width (X8)	X1			0.45
Contact Pad Length (X8)	Y1			1.50
Contact Pad to Center Pad (X6)	G1	0.20		

**Notes:**

- Dimensioning and tolerancing per ASME Y14.5M  
BSC: Basic Dimension. Theoretically exact value shown without tolerances.
- For best soldering results, thermal vias, if used, should be filled or tented to avoid solder loss during reflow process

Microchip Technology Drawing C04-2086 Rev B

**8-Lead Ultra Thin Plastic Dual Flat, No Lead Package (Q4B) - 2x3 mm Body [UDFN]  
Atmel Legacy Global Package Code YNZ**

**Note:** For the most current package drawings, please see the Microchip Packaging Specification located at <http://www.microchip.com/packaging>

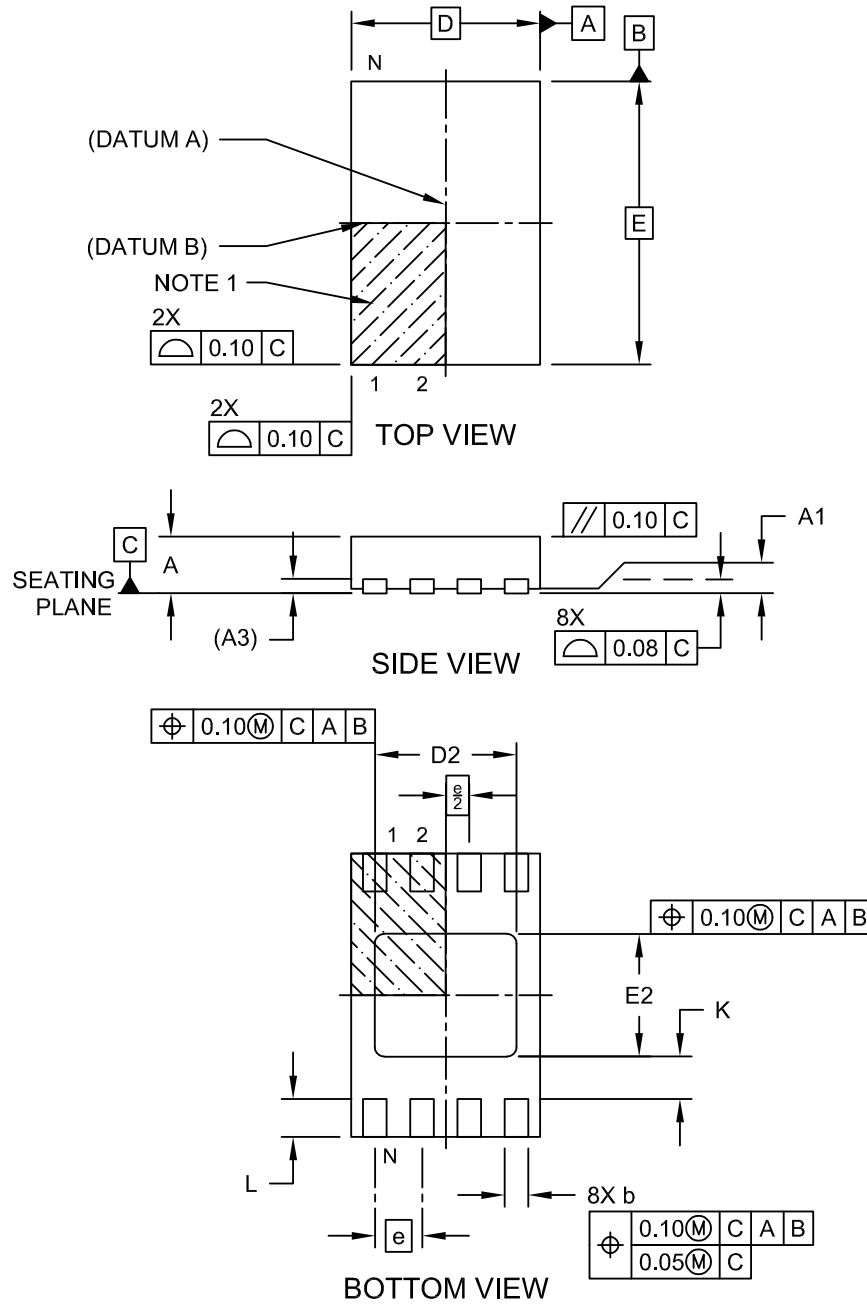

Microchip Technology Drawing C04-21355-Q4B Rev C Sheet 1 of 2

## 8-Lead Ultra Thin Plastic Dual Flat, No Lead Package (Q4B) - 2x3 mm Body [UDFN] Atmel Legacy Global Package Code YNZ

**Note:** For the most current package drawings, please see the Microchip Packaging Specification located at <http://www.microchip.com/packaging>

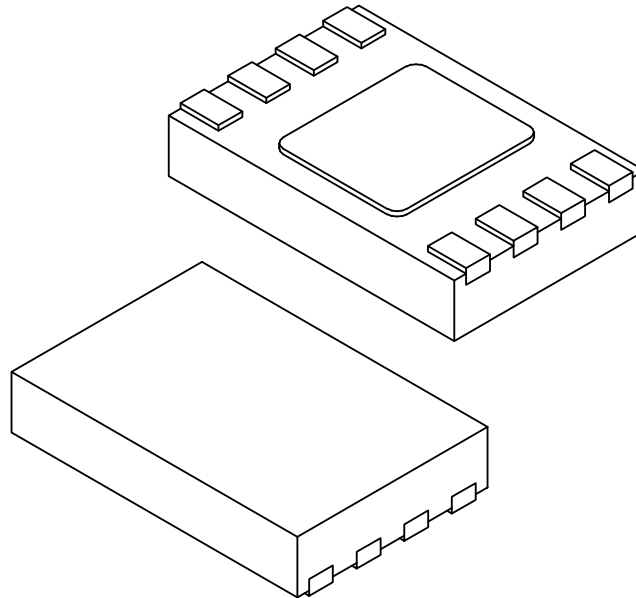

Dimension Limits	Units	MILLIMETERS		
		MIN	NOM	MAX
Number of Terminals	N	8		
Pitch	e	0.50 BSC		
Overall Height	A	0.50	0.55	0.60
Standoff	A1	0.00	0.02	0.05
Terminal Thickness	A3	0.152 REF		
Overall Length	D	2.00 BSC		
Exposed Pad Length	D2	1.40	1.50	1.60
Overall Width	E	3.00 BSC		
Exposed Pad Width	E2	1.20	1.30	1.40
Terminal Width	b	0.18	0.25	0.30
Terminal Length	L	0.25	0.35	0.45
Terminal-to-Exposed-Pad	K	0.20	-	-

**Notes:**

1. Pin 1 visual index feature may vary, but must be located within the hatched area.
2. Package is saw singulated
3. Dimensioning and tolerancing per ASME Y14.5M
  - BSC: Basic Dimension. Theoretically exact value shown without tolerances.
  - REF: Reference Dimension, usually without tolerance, for information purposes only.

Microchip Technology Drawing C04-21355-Q4B Rev C Sheet 2 of 2

## 8-Lead Ultra Thin Plastic Dual Flat, No Lead Package (Q4B) - 2x3 mm Body [UDFN] Atmel Legacy Global Package Code YNZ

**Note:** For the most current package drawings, please see the Microchip Packaging Specification located at <http://www.microchip.com/packaging>

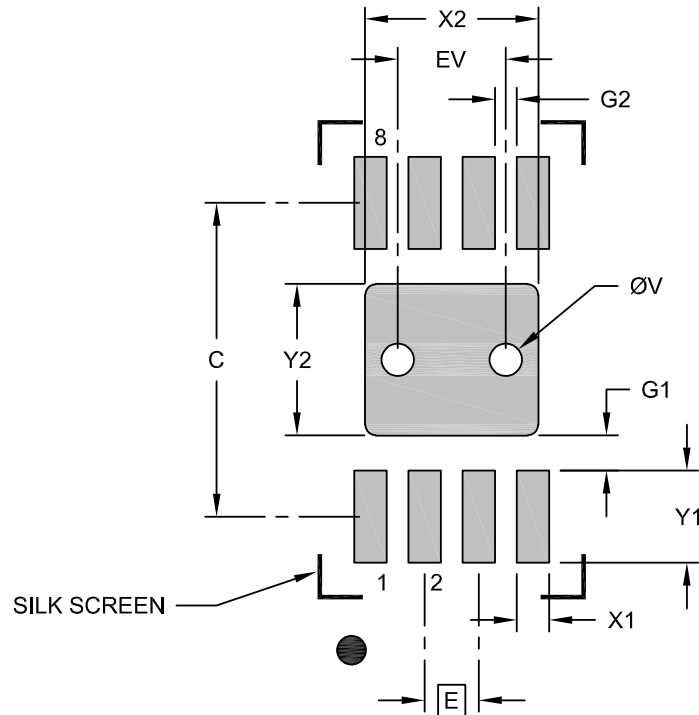

RECOMMENDED LAND PATTERN

Dimension Limits	Units	MILLIMETERS		
		MIN	NOM	MAX
Contact Pitch	E	0.50 BSC		
Optional Center Pad Width	X2			1.60
Optional Center Pad Length	Y2			1.40
Contact Pad Spacing	C	2.90		
Contact Pad Width (X8)	X1			0.30
Contact Pad Length (X8)	Y1			0.85
Contact Pad to Center Pad (X8)	G1	0.33		
Contact Pad to Contact Pad (X6)	G2	0.20		
Thermal Via Diameter	V		0.30	
Thermal Via Pitch	EV		1.00	

**Notes:**

- Dimensioning and tolerancing per ASME Y14.5M  
BSC: Basic Dimension. Theoretically exact value shown without tolerances.
- For best soldering results, thermal vias, if used, should be filled or tented to avoid solder loss during reflow process

Microchip Technology Drawing C04-23355-Q4B Rev C

**5-Lead Plastic Thin Small Outline Transistor (NMB) [TSOT]  
Atmel Legacy Global Package Code TSZ**

**Note:** For the most current package drawings, please see the Microchip Packaging Specification located at <http://www.microchip.com/packaging>

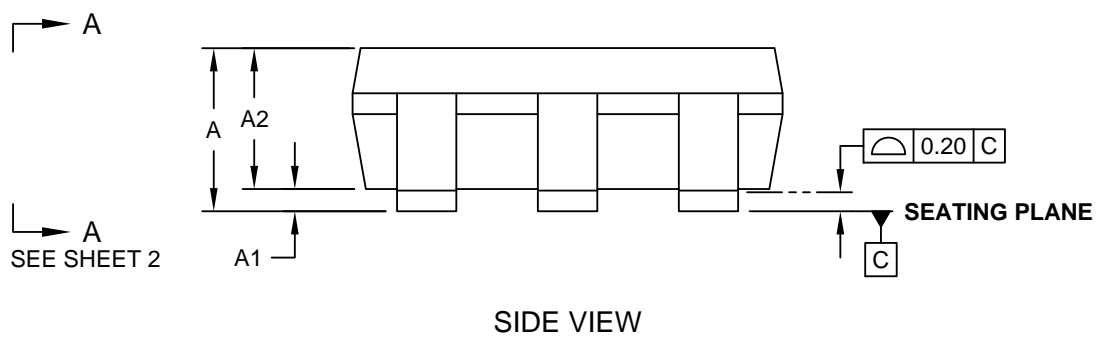
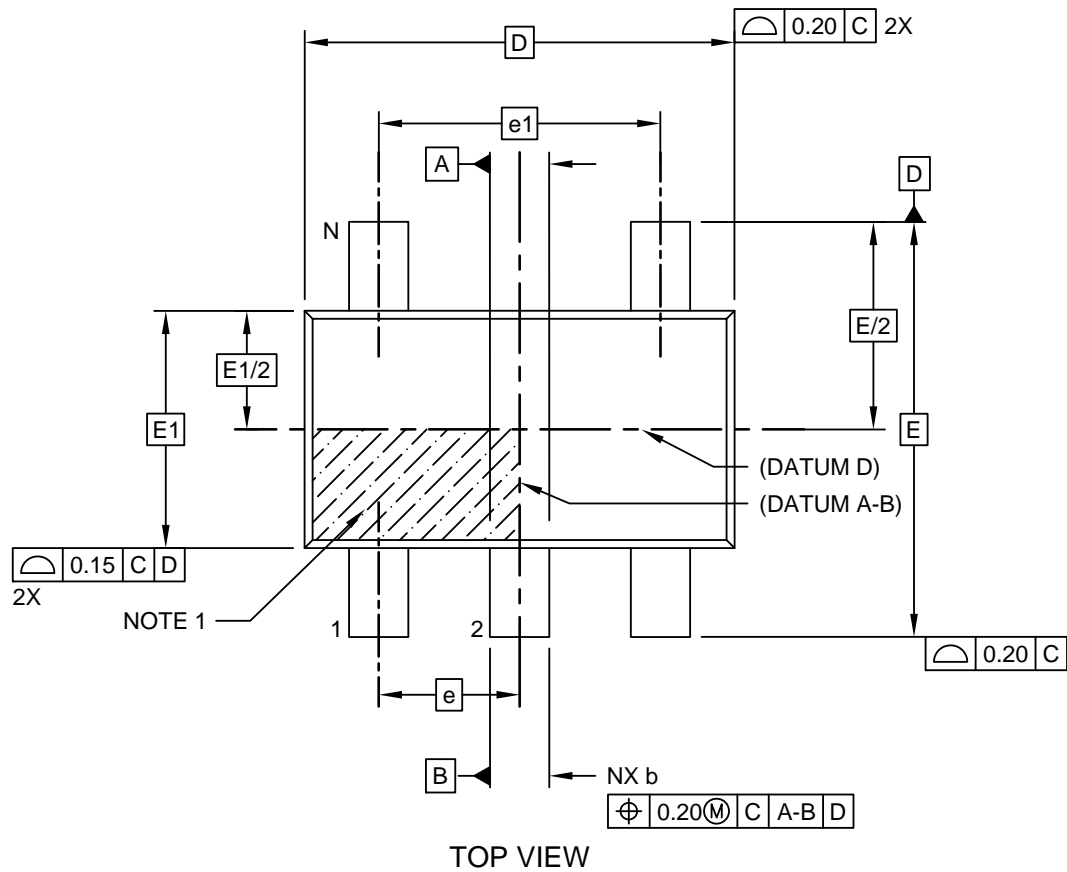

Microchip Technology Drawing C04-21344 Rev B Sheet 1 of 2

## 5-Lead Plastic Thin Small Outline Transistor (NMB) [TSOT] Atmel Legacy Global Package Code TSZ

**Note:** For the most current package drawings, please see the Microchip Packaging Specification located at <http://www.microchip.com/packaging>

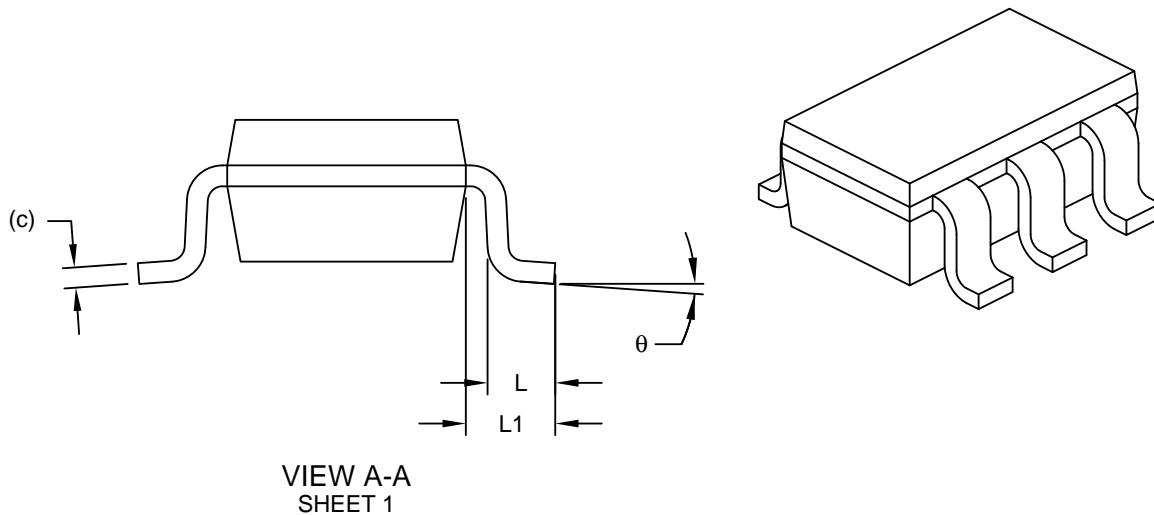

Dimension Limits	Units	MILLIMETERS		
		MIN	NOM	MAX
Number of Leads	N	5		
Pitch	e	0.95 BSC		
Outside lead pitch	e1	1.90 BSC		
Overall Height	A	-	-	1.10
Molded Package Thickness	A2	0.70	0.90	1.00
Standoff	A1	-	-	0.10
Overall Width	E	2.80 BSC		
Molded Package Width	E1	1.60 BSC		
Overall Length	D	2.90 BSC		
Foot Length	L	0.30	-	0.60
Footprint	L1	0.60 REF		
Foot Angle	$\theta$	0°	-	8°
Lead Thickness	c	0.08	-	0.20
Lead Width	b	0.30	-	0.50

**Notes:**

- Dimensions D and E1 do not include mold flash or protrusions. Mold flash or protrusions shall not exceed 0.25mm per side.
- Dimensioning and tolerancing per ASME Y14.5M  
BSC: Basic Dimension. Theoretically exact value shown without tolerances.  
REF: Reference Dimension, usually without tolerance, for information purposes only.

Microchip Technology Drawing C04-21344 Rev B Sheet 2 of 2

## 5-Lead Plastic Thin Small Outline Transistor (NMB) [TSOT] Atmel Legacy Global Package Code TSZ

**Note:** For the most current package drawings, please see the Microchip Packaging Specification located at <http://www.microchip.com/packaging>

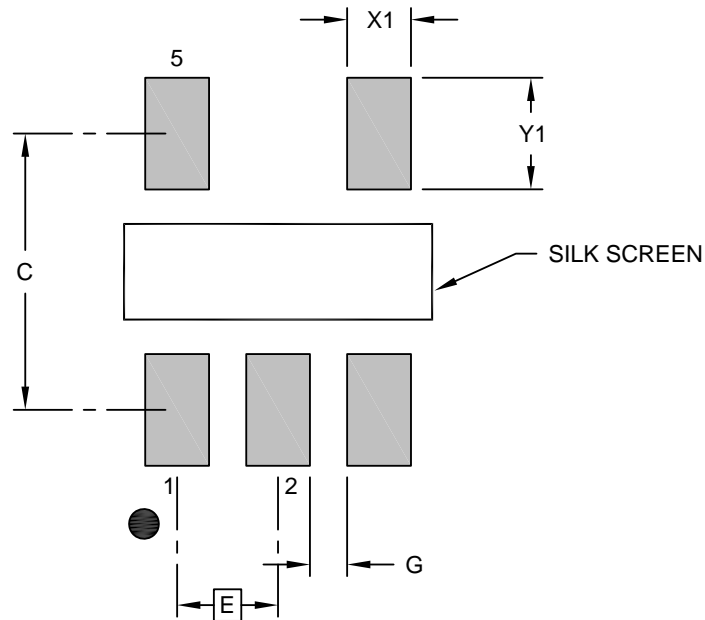

### RECOMMENDED LAND PATTERN

Dimension Limits	Units	MILLIMETERS		
		MIN	NOM	MAX
Contact Pitch	E	0.95 BSC		
Contact Pad Spacing	C		2.60	
Contact Pad Width (X5)	X1			0.60
Contact Pad Length (X5)	Y1			1.05
Contact Pad to Center Pad (X2)	G	0.20		

**Notes:**

- Dimensioning and tolerancing per ASME Y14.5M  
BSC: Basic Dimension. Theoretically exact value shown without tolerances.
- For best soldering results, thermal vias, if used, should be filled or tented to avoid solder loss during reflow process

Microchip Technology Drawing C04-23344 Rev B

## 11. Revision History

### Revision B (April 2025)

Corrected serial number read wording in section 8.4.

### Revision A (April 2020)

Updated to Microchip template. Microchip DS20006342 replaces Atmel document 8859. Corrected  $t_{LOW}$  typo from 400 ns to 500 ns. Corrected  $t_{AA}$  typo from 550 ns to 450 ns. Updated Package Marking Information. Updated the “Software Reset” section. Added ESD rating. Removed lead finish designation. Updated trace code format in package markings. Updated formatting throughout for clarification. Added a figure for “System Configuration Using 2-Wire Serial EEPROMs”. Updated “Block Diagram” figure. Added POR recommendations section. Updated formatting to current template. Updated the SOIC, TSSOP, UDFN and SOT23 package drawings to Microchip format.

### Atmel Document 8859 Revision C (March 2017)

Corrected ISB2 spec to 6.0  $\mu$ A.

### Atmel Document 8859 Revision B (January 2015)

Added bulk SOIC and TSSOP, and UDFN Expanded Quantity options. Updated from preliminary to complete status, ordering code table, 8X and 8MA2 package drawings and the disclaimer page. Corrected pinouts from bottom to top view and reorganization figures. No changes to functional specification.

### Atmel Document 8859 Revision A (February 2013)

Initial release of this document.

## 12. Product Identification System

To order or obtain information, e.g., on pricing or delivery, refer to the factory or the listed sales office.

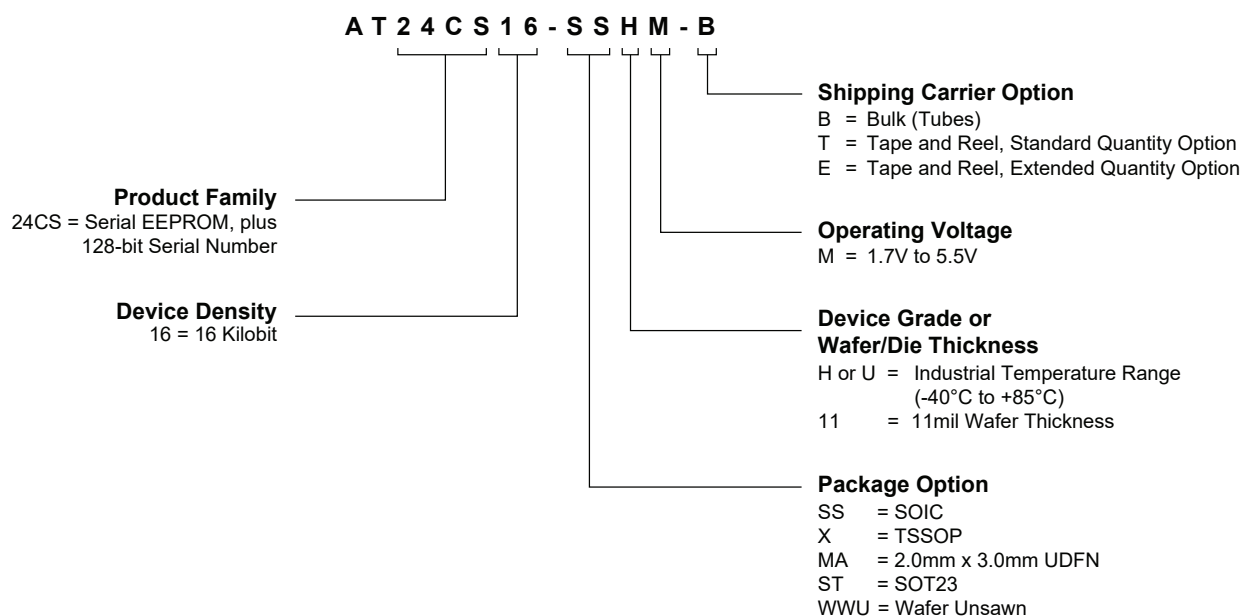

### Examples

Device	Package	Package Drawing Code	Package Option	Shipping Carrier Option	Device Grade
AT24CS16-SSHMB	SOIC	SN	SS	Bulk (Tubes)	Industrial Temperature (-40°C to +85°C)
AT24CS16-SSHMT	SOIC	SN	SS	Tape and Reel	
AT24CS16-XHMB	TSSOP	ST	X	Bulk (Tubes)	
AT24CS16-XHMT	TSSOP	ST	X	Tape and Reel	
AT24CS16-MAHMT	UDFN	Q4B	MA	Tape and Reel	
AT24CS16-MAHME	UDFN	Q4B	MA	Extended Qty. Tape and Reel	
AT24CS16-STUMT	SOT23	NMB	ST	Tape and Reel	

## Microchip Information

### Trademarks

The “Microchip” name and logo, the “M” logo, and other names, logos, and brands are registered and unregistered trademarks of Microchip Technology Incorporated or its affiliates and/or subsidiaries in the United States and/or other countries (“Microchip Trademarks”). Information regarding Microchip Trademarks can be found at <https://www.microchip.com/en-us/about/legal-information/microchip-trademarks>.

ISBN: 979-8-3371-0915-2

### Legal Notice

This publication and the information herein may be used only with Microchip products, including to design, test, and integrate Microchip products with your application. Use of this information in any other manner violates these terms. Information regarding device applications is provided only for your convenience and may be superseded by updates. It is your responsibility to ensure that your application meets with your specifications. Contact your local Microchip sales office for additional support or, obtain additional support at [www.microchip.com/en-us/support/design-help/client-support-services](http://www.microchip.com/en-us/support/design-help/client-support-services).

THIS INFORMATION IS PROVIDED BY MICROCHIP “AS IS”. MICROCHIP MAKES NO REPRESENTATIONS OR WARRANTIES OF ANY KIND WHETHER EXPRESS OR IMPLIED, WRITTEN OR ORAL, STATUTORY OR OTHERWISE, RELATED TO THE INFORMATION INCLUDING BUT NOT LIMITED TO ANY IMPLIED WARRANTIES OF NON-INFRINGEMENT, MERCHANTABILITY, AND FITNESS FOR A PARTICULAR PURPOSE, OR WARRANTIES RELATED TO ITS CONDITION, QUALITY, OR PERFORMANCE.

IN NO EVENT WILL MICROCHIP BE LIABLE FOR ANY INDIRECT, SPECIAL, PUNITIVE, INCIDENTAL, OR CONSEQUENTIAL LOSS, DAMAGE, COST, OR EXPENSE OF ANY KIND WHATSOEVER RELATED TO THE INFORMATION OR ITS USE, HOWEVER CAUSED, EVEN IF MICROCHIP HAS BEEN ADVISED OF THE POSSIBILITY OR THE DAMAGES ARE FORESEEABLE. TO THE FULLEST EXTENT ALLOWED BY LAW, MICROCHIP’S TOTAL LIABILITY ON ALL CLAIMS IN ANY WAY RELATED TO THE INFORMATION OR ITS USE WILL NOT EXCEED THE AMOUNT OF FEES, IF ANY, THAT YOU HAVE PAID DIRECTLY TO MICROCHIP FOR THE INFORMATION.

Use of Microchip devices in life support and/or safety applications is entirely at the buyer’s risk, and the buyer agrees to defend, indemnify and hold harmless Microchip from any and all damages, claims, suits, or expenses resulting from such use. No licenses are conveyed, implicitly or otherwise, under any Microchip intellectual property rights unless otherwise stated.

### Microchip Devices Code Protection Feature

Note the following details of the code protection feature on Microchip products:

- Microchip products meet the specifications contained in their particular Microchip Data Sheet.
- Microchip believes that its family of products is secure when used in the intended manner, within operating specifications, and under normal conditions.
- Microchip values and aggressively protects its intellectual property rights. Attempts to breach the code protection features of Microchip products are strictly prohibited and may violate the Digital Millennium Copyright Act.
- Neither Microchip nor any other semiconductor manufacturer can guarantee the security of its code. Code protection does not mean that we are guaranteeing the product is “unbreakable”. Code protection is constantly evolving. Microchip is committed to continuously improving the code protection features of our products.

## Product Page Links

[AT24CS16](#)