

---

---

## Low-BOM Microphone Interface Using the Analog Signal Conditioning (OPAMP) Peripheral

---

---

### Introduction

---

Author: Lloyd D. Clark, Ph.D., Microchip Technology Inc.

An electret microphone produces an audio output signal in the millivolt range. To interface an electret microphone with a microcontroller (MCU), it is necessary to amplify the signal up to the 100-millivolt range so that it can be detected by an analog comparator in the MCU or converted to a digital signal by the MCU's analog-to-digital converter (ADC). Conventionally, it has been necessary to add one or two operational amplifier (op amp) integrated circuits and several passive components to a hardware design to perform this amplification. An MCU containing the Analog Signal Conditioning (OPAMP) peripheral can be interfaced with an electret microphone using minimal external circuitry because the OPAMP peripheral is capable of linear amplification. In addition to the microphone, only one resistor and one capacitor are required. The OPAMP peripheral also provides the ability to adjust the gain under firmware control.

### Features

---

- Electret Microphone Amplifier Using Microcontroller's Analog Signal Conditioning (OPAMP) Peripheral
- Adjustable Gain Under Firmware Control
- Low Bill of Materials – Only Two External Components Required in Addition to Microphone:
  - One resistor
  - One capacitor

---

## Table of Contents

---

Introduction.....	1
Features.....	1
1. Relevant Devices.....	3
2. Conventional Electret Microphone Interface.....	4
3. Electret Microphone Interface Using OPAMP Peripheral.....	5
4. OPAMP Configuration Code.....	6
5. Revision History.....	7
The Microchip Website.....	8
Product Change Notification Service.....	8
Customer Support.....	8
Microchip Devices Code Protection Feature.....	8
Legal Notice.....	8
Trademarks.....	9
Quality Management System.....	9
Worldwide Sales and Service.....	10

## 1. Relevant Devices

This section lists the relevant devices for this document. The following figures show the different family devices, laying out pin count variants and memory sizes:

- Vertical migration upwards is possible without code modification, as these devices are pin-compatible and provide the same or more features
- Horizontal migration to the left reduces the pin count and, therefore, the available features
- Devices with different Flash memory sizes typically also have different SRAM and EEPROM

**Figure 1-1. AVR® DB Family Overview**

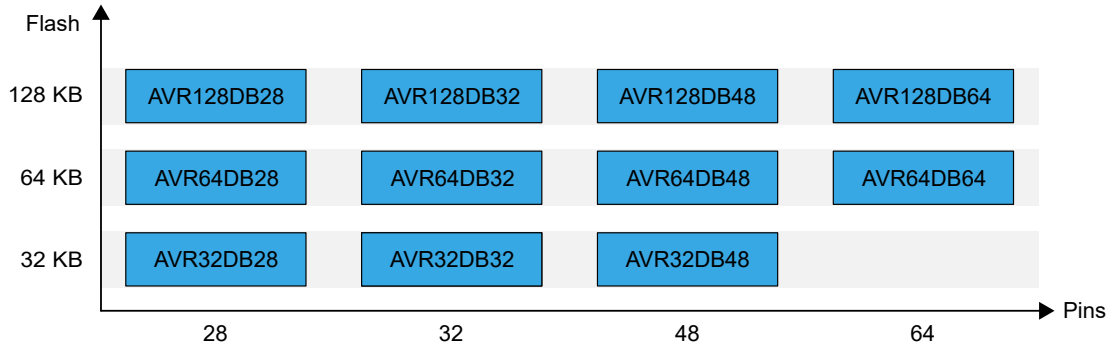

## 2. Conventional Electret Microphone Interface

To interface an electret microphone with a microcontroller (MCU), it has conventionally been necessary to use one or two op amp integrated circuits and some resistors to amplify the signal.

**Figure 2-1. Schematic Diagram of Conventional Microphone Interface**

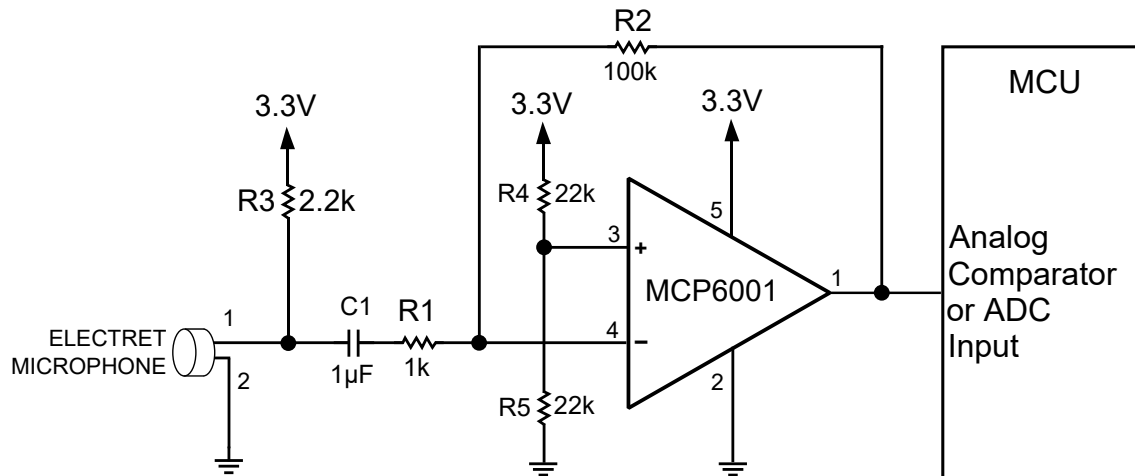

The schematic diagram of a conventional electret microphone interface is shown in the figure above. An electret microphone requires a pullup resistor to  $V_{DD}$  to bias it – this function is provided by resistor R3. The millivolt audio output signal appears at pin 1 of the electret microphone, but it is superimposed on a DC voltage. Capacitor C1 blocks the DC voltage from the rest of the circuit to prevent saturation, and the capacitor value is sized to allow audio frequencies to pass through it. The MCP6001 op amp is wired in an inverting amplifier configuration, with the gain determined by the ratio  $-R2/R1$ . A voltage divider consisting of R4 and R5 biases the non-inverting (+) input of the op amp at  $V_{DD}/2$ . This causes the amplified audio output at pin 1 of the op amp to be centered around a DC voltage of  $V_{DD}/2$ . This output is suitable for direct connection to either an analog comparator input or analog-to-digital converter (ADC) input of an MCU.

The conventional electret microphone interface has a few drawbacks. Not only does it require several passive and active components to be added to the hardware design, but it also does not provide a mechanism for the MCU to adjust the gain of the amplifier under firmware control.

### 3. Electret Microphone Interface Using OPAMP Peripheral

The microcontroller's (MCU's) OPAMP peripheral can be configured to linearly amplify millivolt-level signals. This capability can be used to greatly simplify the hardware interface with an electret microphone.

**Figure 3-1. Schematic Diagram of Microphone Interface Using OPAMP Peripheral**

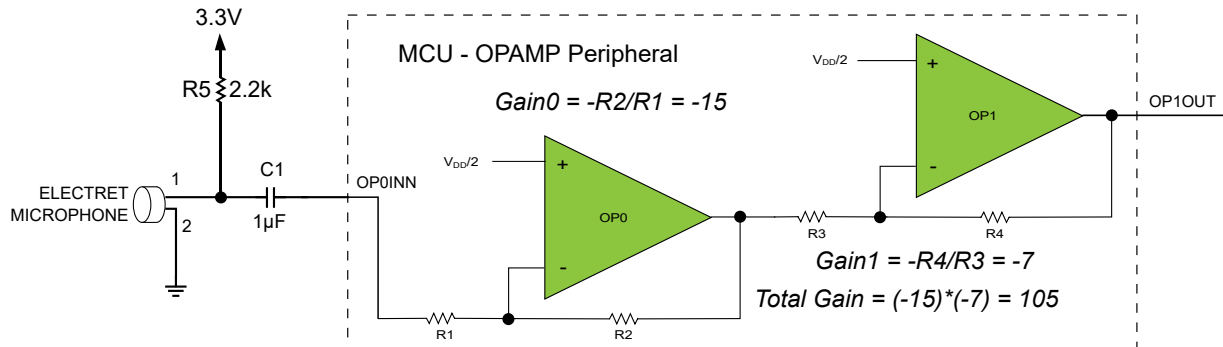

The schematic diagram of the electret microphone interface with the MCU is shown in the figure above. Only two components are required in addition to the microphone and MCU: Resistor R5 for biasing the microphone, and capacitor C1 for blocking the DC voltage and allowing the audio signal to pass through. The remainder of the amplification circuit is provided by the OPAMP peripheral inside the MCU.

As shown in the schematic diagram, op amps OP0 and OP1 inside the MCU's OPAMP peripheral are configured as cascaded inverting amplifiers, using resistors that are also inside the OPAMP peripheral. The gain of the OP0 stage is determined by the ratio  $-R2/R1$ , and the gain of the OP1 stage is determined by the ratio  $-R4/R3$ . In the schematic, the first stage is shown with a gain of -15 and the second stage is shown with a gain of -7 for an overall gain of 105. Because the resistor ratios can be changed under firmware control, it is possible for the MCU to adjust the gain if needed. For example, in a high-noise environment, a gain of 105 might be too large, causing the output signal to saturate and distort. In this case, the gain of one or both op amps could be reduced as needed.

Depending on the requirements of the application, output pin OP1OUT can be connected via a circuit board trace to external circuitry, or it can be used as either an analog comparator input or an analog-to-digital converter (ADC) input on the same pin of the MCU.

## 4. OPAMP Configuration Code

Just a few lines of code are required to configure the OPAMP peripheral to implement the electret microphone amplifier in [Figure 3-1](#):

```
// Set up the timebase of the OPAMP peripheral
OPAMP.TIMEBASE = 3; // Number of CLK_PER cycles that equal one us, minus one (4-1=3)

//Make OP0 an inverting PGA with gain of -15
OPAMP.OP0INMUX = OPAMP_OP0INMUX_MUXPOS_VDDDIV2_gc | OPAMP_OP0INMUX_MUXNEG_WIP_gc;
OPAMP.OP0RESMUX = OPAMP_OP0RESMUX_MUXB0T_INN_gc | OPAMP_OP0RESMUX_MUXWIP_WIP7_gc |
OPAMP_OP0RESMUX_MUXTOP_OUT_gc;
// Configure OP0 Control A
OPAMP.OP0CTRLA = OPAMP_OP0CTRLA_OUTMODE_NORMAL_gc | OPAMP_ALWAYS_ON_bm;

//Make OP1 an inverting PGA with gain of -7
OPAMP.OP1INMUX = OPAMP_OP1INMUX_MUXPOS_VDDDIV2_gc | OPAMP_OP1INMUX_MUXNEG_WIP_gc;
OPAMP.OP1RESMUX = OPAMP_OP1RESMUX_MUXB0T_LINKOUT_gc | OPAMP_OP1RESMUX_MUXWIP_WIP6_gc |
OPAMP_OP1RESMUX_MUXTOP_OUT_gc;
// Configure OP1 Control A
OPAMP.OP1CTRLA = OPAMP_OP1CTRLA_OUTMODE_NORMAL_gc | OPAMP_ALWAYS_ON_bm;

// Enable the OPAMP peripheral
OPAMP.CTRLA = OPAMP_ENABLE_bm;
```

After this code has been executed, the op amps stay active, and no further CPU intervention is required.



[View Code Example on GitHub](#)  
Click to browse repository

**5. Revision History**

Doc. Rev.	Date	Comments
A	09/2020	Initial document release

---

## The Microchip Website

---

Microchip provides online support via our website at [www.microchip.com/](http://www.microchip.com/). This website is used to make files and information easily available to customers. Some of the content available includes:

- **Product Support** – Data sheets and errata, application notes and sample programs, design resources, user's guides and hardware support documents, latest software releases and archived software
- **General Technical Support** – Frequently Asked Questions (FAQs), technical support requests, online discussion groups, Microchip design partner program member listing
- **Business of Microchip** – Product selector and ordering guides, latest Microchip press releases, listing of seminars and events, listings of Microchip sales offices, distributors and factory representatives

---

## Product Change Notification Service

---

Microchip's product change notification service helps keep customers current on Microchip products. Subscribers will receive email notification whenever there are changes, updates, revisions or errata related to a specified product family or development tool of interest.

To register, go to [www.microchip.com/pcn](http://www.microchip.com/pcn) and follow the registration instructions.

---

## Customer Support

---

Users of Microchip products can receive assistance through several channels:

- Distributor or Representative
- Local Sales Office
- Embedded Solutions Engineer (ESE)
- Technical Support

Customers should contact their distributor, representative or ESE for support. Local sales offices are also available to help customers. A listing of sales offices and locations is included in this document.

Technical support is available through the website at: [www.microchip.com/support](http://www.microchip.com/support)

---

## Microchip Devices Code Protection Feature

---

Note the following details of the code protection feature on Microchip devices:

- Microchip products meet the specifications contained in their particular Microchip Data Sheet.
- Microchip believes that its family of products is secure when used in the intended manner and under normal conditions.
- There are dishonest and possibly illegal methods being used in attempts to breach the code protection features of the Microchip devices. We believe that these methods require using the Microchip products in a manner outside the operating specifications contained in Microchip's Data Sheets. Attempts to breach these code protection features, most likely, cannot be accomplished without violating Microchip's intellectual property rights.
- Microchip is willing to work with any customer who is concerned about the integrity of its code.
- Neither Microchip nor any other semiconductor manufacturer can guarantee the security of its code. Code protection does not mean that we are guaranteeing the product is "unbreakable." Code protection is constantly evolving. We at Microchip are committed to continuously improving the code protection features of our products. Attempts to break Microchip's code protection feature may be a violation of the Digital Millennium Copyright Act. If such acts allow unauthorized access to your software or other copyrighted work, you may have a right to sue for relief under that Act.

---

## Legal Notice

---

Information contained in this publication regarding device applications and the like is provided only for your convenience and may be superseded by updates. It is your responsibility to ensure that your application meets with

---

your specifications. MICROCHIP MAKES NO REPRESENTATIONS OR WARRANTIES OF ANY KIND WHETHER EXPRESS OR IMPLIED, WRITTEN OR ORAL, STATUTORY OR OTHERWISE, RELATED TO THE INFORMATION, INCLUDING BUT NOT LIMITED TO ITS CONDITION, QUALITY, PERFORMANCE, MERCHANTABILITY OR FITNESS FOR PURPOSE. Microchip disclaims all liability arising from this information and its use. Use of Microchip devices in life support and/or safety applications is entirely at the buyer's risk, and the buyer agrees to defend, indemnify and hold harmless Microchip from any and all damages, claims, suits, or expenses resulting from such use. No licenses are conveyed, implicitly or otherwise, under any Microchip intellectual property rights unless otherwise stated.

## Trademarks

---

The Microchip name and logo, the Microchip logo, Adaptec, AnyRate, AVR, AVR logo, AVR Freaks, BesTime, BitCloud, chipKIT, chipKIT logo, CryptoMemory, CryptoRF, dsPIC, FlashFlex, flexPWR, HELDO, IGLOO, JukeBlox, KeeLoq, Kleer, LANCheck, LinkMD, maXStylus, maXTouch, MediaLB, megaAVR, Microsemi, Microsemi logo, MOST, MOST logo, MPLAB, OptoLyzer, PackeTime, PIC, picoPower, PICSTART, PIC32 logo, PolarFire, Prochip Designer, QTouch, SAM-BA, SenGenuity, SpyNIC, SST, SST Logo, SuperFlash, Symmetricom, SyncServer, Tachyon, TempTrackr, TimeSource, tinyAVR, UNI/O, Vectron, and XMEGA are registered trademarks of Microchip Technology Incorporated in the U.S.A. and other countries.

APT, ClockWorks, The Embedded Control Solutions Company, EtherSynch, FlashTec, Hyper Speed Control, HyperLight Load, IntelliMOS, Libero, motorBench, mTouch, Powermite 3, Precision Edge, ProASIC, ProASIC Plus, ProASIC Plus logo, Quiet-Wire, SmartFusion, SyncWorld, Temux, TimeCesium, TimeHub, TimePictra, TimeProvider, Vite, WinPath, and ZL are registered trademarks of Microchip Technology Incorporated in the U.S.A.

Adjacent Key Suppression, AKS, Analog-for-the-Digital Age, Any Capacitor, AnyIn, AnyOut, BlueSky, BodyCom, CodeGuard, CryptoAuthentication, CryptoAutomotive, CryptoCompanion, CryptoController, dsPICDEM, dsPICDEM.net, Dynamic Average Matching, DAM, ECAN, EtherGREEN, In-Circuit Serial Programming, ICSP, INICnet, Inter-Chip Connectivity, JitterBlocker, KleerNet, KleerNet logo, memBrain, Mindi, MiWi, MPASM, MPF, MPLAB Certified logo, MPLIB, MPLINK, MultiTRAK, NetDetach, Omniscient Code Generation, PICDEM, PICDEM.net, PICkit, PICtail, PowerSmart, PureSilicon, QMatrix, REAL ICE, Ripple Blocker, SAM-ICE, Serial Quad I/O, SMART-I.S., SQI, SuperSwitcher, SuperSwitcher II, Total Endurance, TSHARC, USBCheck, VariSense, ViewSpan, WiperLock, Wireless DNA, and ZENA are trademarks of Microchip Technology Incorporated in the U.S.A. and other countries.

SQTP is a service mark of Microchip Technology Incorporated in the U.S.A.

The Adaptec logo, Frequency on Demand, Silicon Storage Technology, and Symmcom are registered trademarks of Microchip Technology Inc. in other countries.

GestIC is a registered trademark of Microchip Technology Germany II GmbH & Co. KG, a subsidiary of Microchip Technology Inc., in other countries.

All other trademarks mentioned herein are property of their respective companies.

© 2020, Microchip Technology Incorporated, Printed in the U.S.A., All Rights Reserved.

ISBN: 978-1-5224-6634-5

## Quality Management System

---

For information regarding Microchip's Quality Management Systems, please visit [www.microchip.com/quality](http://www.microchip.com/quality).

## Worldwide Sales and Service

AMERICAS	ASIA/PACIFIC	ASIA/PACIFIC	EUROPE
<p><b>Corporate Office</b> 2355 West Chandler Blvd. Chandler, AZ 85224-6199 Tel: 480-792-7200 Tel: 480-792-7277 Technical Support: <a href="http://www.microchip.com/support">www.microchip.com/support</a> Web Address: <a href="http://www.microchip.com">www.microchip.com</a></p> <p><b>Atlanta</b> Duluth, GA Tel: 678-957-9614 Fax: 678-957-1455</p> <p><b>Austin, TX</b> Tel: 512-257-3370</p> <p><b>Boston</b> Westborough, MA Tel: 774-760-0087 Fax: 774-760-0088</p> <p><b>Chicago</b> Itasca, IL Tel: 630-285-0071 Fax: 630-285-0075</p> <p><b>Dallas</b> Addison, TX Tel: 972-818-7423 Fax: 972-818-2924</p> <p><b>Detroit</b> Novi, MI Tel: 248-848-4000</p> <p><b>Houston, TX</b> Tel: 281-894-5983</p> <p><b>Indianapolis</b> Noblesville, IN Tel: 317-773-8323 Fax: 317-773-5453 Tel: 317-536-2380</p> <p><b>Los Angeles</b> Mission Viejo, CA Tel: 949-462-9523 Fax: 949-462-9608 Tel: 951-273-7800</p> <p><b>Raleigh, NC</b> Tel: 919-844-7510</p> <p><b>New York, NY</b> Tel: 631-435-6000</p> <p><b>San Jose, CA</b> Tel: 408-735-9110 Tel: 408-436-4270</p> <p><b>Canada - Toronto</b> Tel: 905-695-1980 Fax: 905-695-2078</p>	<p><b>Australia - Sydney</b> Tel: 61-2-9868-6733</p> <p><b>China - Beijing</b> Tel: 86-10-8569-7000</p> <p><b>China - Chengdu</b> Tel: 86-28-8665-5511</p> <p><b>China - Chongqing</b> Tel: 86-23-8980-9588</p> <p><b>China - Dongguan</b> Tel: 86-769-8702-9880</p> <p><b>China - Guangzhou</b> Tel: 86-20-8755-8029</p> <p><b>China - Hangzhou</b> Tel: 86-571-8792-8115</p> <p><b>China - Hong Kong SAR</b> Tel: 852-2943-5100</p> <p><b>China - Nanjing</b> Tel: 86-25-8473-2460</p> <p><b>China - Qingdao</b> Tel: 86-532-8502-7355</p> <p><b>China - Shanghai</b> Tel: 86-21-3326-8000</p> <p><b>China - Shenyang</b> Tel: 86-24-2334-2829</p> <p><b>China - Shenzhen</b> Tel: 86-755-8864-2200</p> <p><b>China - Suzhou</b> Tel: 86-186-6233-1526</p> <p><b>China - Wuhan</b> Tel: 86-27-5980-5300</p> <p><b>China - Xian</b> Tel: 86-29-8833-7252</p> <p><b>China - Xiamen</b> Tel: 86-592-2388138</p> <p><b>China - Zhuhai</b> Tel: 86-756-3210040</p>	<p><b>India - Bangalore</b> Tel: 91-80-3090-4444</p> <p><b>India - New Delhi</b> Tel: 91-11-4160-8631</p> <p><b>India - Pune</b> Tel: 91-20-4121-0141</p> <p><b>Japan - Osaka</b> Tel: 81-6-6152-7160</p> <p><b>Japan - Tokyo</b> Tel: 81-3-6880-3770</p> <p><b>Korea - Daegu</b> Tel: 82-53-744-4301</p> <p><b>Korea - Seoul</b> Tel: 82-2-554-7200</p> <p><b>Malaysia - Kuala Lumpur</b> Tel: 60-3-7651-7906</p> <p><b>Malaysia - Penang</b> Tel: 60-4-227-8870</p> <p><b>Philippines - Manila</b> Tel: 63-2-634-9065</p> <p><b>Singapore</b> Tel: 65-6334-8870</p> <p><b>Taiwan - Hsin Chu</b> Tel: 886-3-577-8366</p> <p><b>Taiwan - Kaohsiung</b> Tel: 886-7-213-7830</p> <p><b>Taiwan - Taipei</b> Tel: 886-2-2508-8600</p> <p><b>Thailand - Bangkok</b> Tel: 66-2-694-1351</p> <p><b>Vietnam - Ho Chi Minh</b> Tel: 84-28-5448-2100</p>	<p><b>Austria - Wels</b> Tel: 43-7242-2244-39 Fax: 43-7242-2244-393</p> <p><b>Denmark - Copenhagen</b> Tel: 45-4485-5910 Fax: 45-4485-2829</p> <p><b>Finland - Espoo</b> Tel: 358-9-4520-820</p> <p><b>France - Paris</b> Tel: 33-1-69-53-63-20 Fax: 33-1-69-30-90-79</p> <p><b>Germany - Garching</b> Tel: 49-8931-9700</p> <p><b>Germany - Haan</b> Tel: 49-2129-3766400</p> <p><b>Germany - Heilbronn</b> Tel: 49-7131-72400</p> <p><b>Germany - Karlsruhe</b> Tel: 49-721-625370</p> <p><b>Germany - Munich</b> Tel: 49-89-627-144-0 Fax: 49-89-627-144-44</p> <p><b>Germany - Rosenheim</b> Tel: 49-8031-354-560</p> <p><b>Israel - Ra'anana</b> Tel: 972-9-744-7705</p> <p><b>Italy - Milan</b> Tel: 39-0331-742611 Fax: 39-0331-466781</p> <p><b>Italy - Padova</b> Tel: 39-049-7625286</p> <p><b>Netherlands - Drunen</b> Tel: 31-416-690399 Fax: 31-416-690340</p> <p><b>Norway - Trondheim</b> Tel: 47-72884388</p> <p><b>Poland - Warsaw</b> Tel: 48-22-3325737</p> <p><b>Romania - Bucharest</b> Tel: 40-21-407-87-50</p> <p><b>Spain - Madrid</b> Tel: 34-91-708-08-90 Fax: 34-91-708-08-91</p> <p><b>Sweden - Gothenberg</b> Tel: 46-31-704-60-40</p> <p><b>Sweden - Stockholm</b> Tel: 46-8-5090-4654</p> <p><b>UK - Wokingham</b> Tel: 44-118-921-5800 Fax: 44-118-921-5820</p>