Hardware Design Checklist

1.0 INTRODUCTION

This document provides a hardware design checklist for the Microchip USB2641. These checklist items should be followed when utilizing the USB2641 in a new design. A summary of these items is provided in [Section 9.0, "Hardware Checklist Summary," on page 19](#). Detailed information on these subjects can be found in the corresponding sections:

- [Section 2.0, "General Considerations"](#)
- [Section 3.0, "Power"](#)
- [Section 4.0, "USB Signals"](#)
- [Section 5.0, "Card Reader Interface"](#)
- [Section 6.0, "Clock Circuit"](#)
- [Section 7.0, "Power and Startup"](#)
- [Section 8.0, "Configuration Options"](#)

2.0 GENERAL CONSIDERATIONS

2.1 Required References

The USB2641 implementor should have the following documents on hand:

- *USB2641 Data Sheet*
- USB2.0 Specification
- MultiMediaCard 4.2 Specification
- Secure Digital 2.0 Specification
- Other references on the product page at www.microchip.com

2.2 Pin Check

Check the pinout of the part against the data sheet. Ensure all pins match the data sheet and are configured as inputs, outputs, or bidirectional for error checking.

2.3 Ground

- The ground ePad, VSS, should be connected to the solid ground plane on the board.
- It is recommended that all ground connections be tied together to the same ground plane. Separate ground planes are not recommended.

2.4 USB-IF Compliant USB Connector

- USB-IF certified USB Connector with a valid Test ID (TID) are required for all USB products to be compliant and pass USB-IF product certification.

3.0 POWER

- The 3.3V supplies (VDD33/VDDA33) are the analog and digital domain power supply inputs. They are located on pins 5, 12, 16, 25, 34, 41, and 48. These pins require a connection to a regulated 3.3V power plane and each should include 0.1 μ F capacitors to decouple the device. The capacitor size should be SMD_0603 or smaller.
- Pins 16 (VDD33) and 48 (VDDA33) each also require a 4.7 μ F bulk capacitor.
- Pin 46 (PLLFLT) is a power bypass for the PLL and should connect to an external filter capacitor. A 1.0 μ F capacitor is recommended. Do not power external circuitry from this regulator output.

USB2641

- Pin 15 (CRFILT) is a digital core regulator output and should connect to an external filter capacitor. A 1.0 μF capacitor is recommended. Do not power external circuitry from this regulator output.

The power and ground connections are shown in [Figure 3-1](#).

FIGURE 3-1: POWER AND GROUND CONNECTIONS

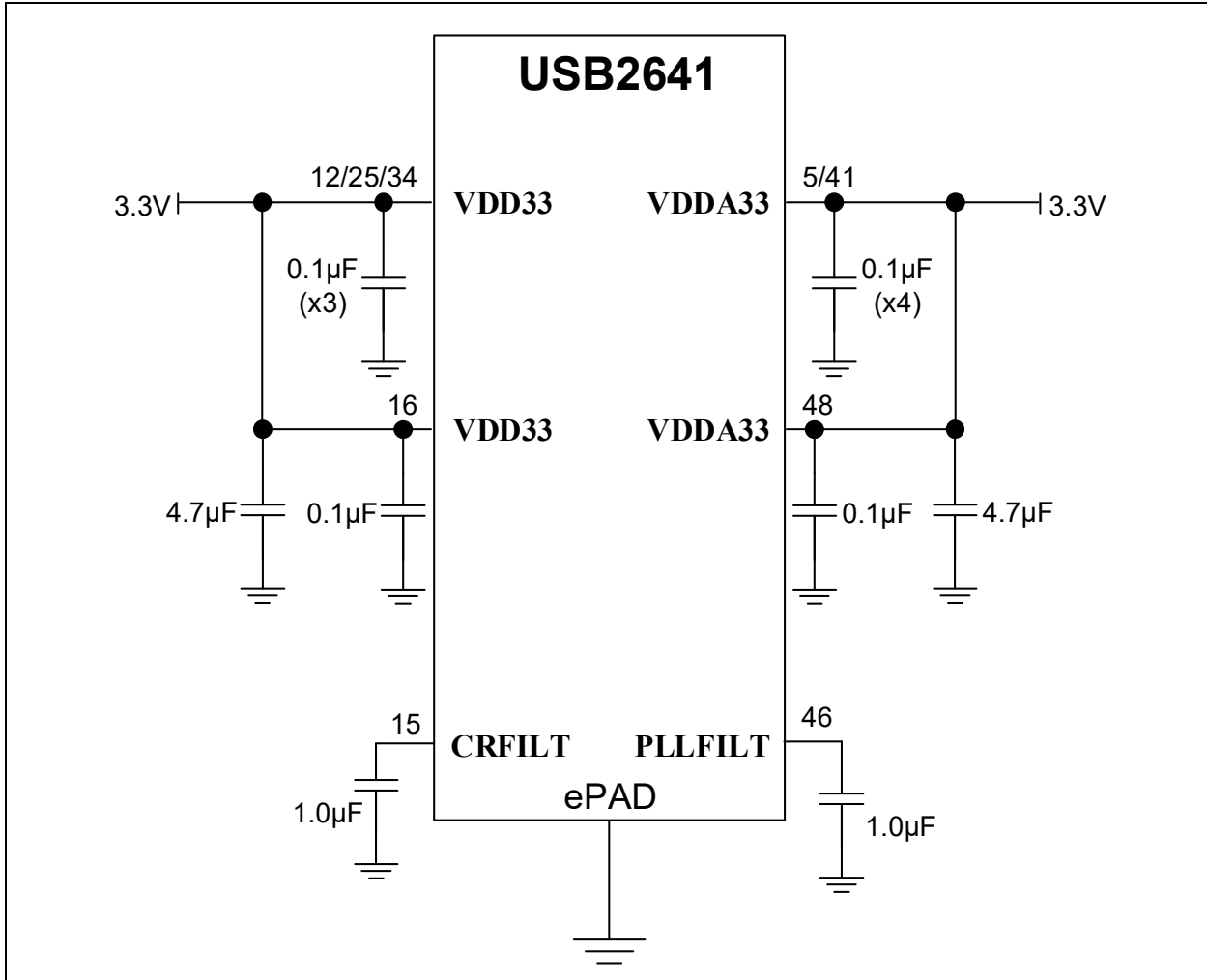

4.0 USB SIGNALS

4.1 Upstream USB Interface

- **USB+** (pin 42): This pin is the positive (+) signal of the upstream USB2.0 differential pair. All necessary USB terminations and resistors are included in the IC. This pin can connect directly to the D+/DP pin of a USB connector.
- **USB-** (pin 43): This pin is the negative (-) signal of the upstream USB2.0 differential pair. All necessary USB terminations and resistors are included in the IC. This pin can connect directly to the D-/DM pin of a USB Connector.
- **VBUS_DET** (pin 39): This pin is used to detect the presence of a USB host. Since a standard VBUS supply is nominally 5V, VBUS must be divided down to a voltage level that it can accept. The **VBUS_DET** pin uses 3.3V logic levels, so a resistor divider consisting of two 100 k Ω resistors is generally recommended, even though precise values are not critical as long as logical high is presented to the pin when a valid VBUS voltage is present on the USB connector.
 - **Optional:** An additional capacitor and/or ferrite bead between the **VBUS** pin of the USB connector and the **VBUS_DET** pin provides the device some immunity from noise or transients on the **VBUS** line. It is generally recommended to design in extra population options for series and parallel components which may be added to the system if additional components are deemed necessary during system testing or qualification.

For transmit and receive channel connection details, refer to [Figure 4-1](#).

FIGURE 4-1: USB DATA SIGNAL CONNECTIONS

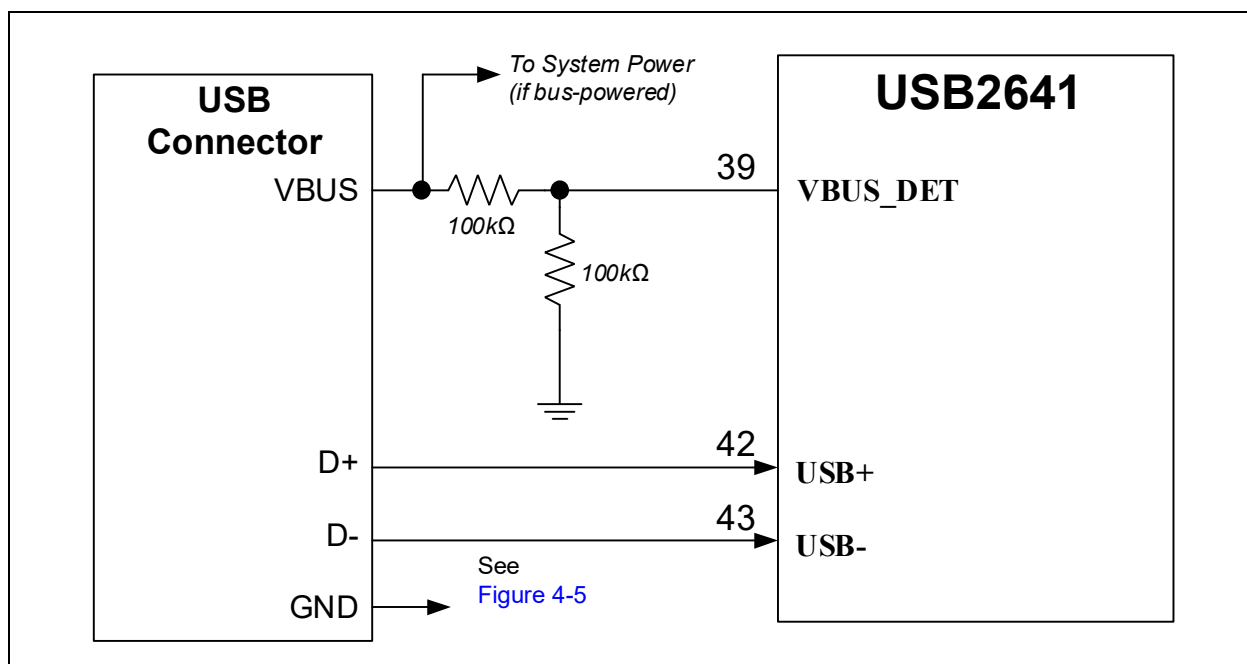

4.2 Downstream USB Ports

4.2.1 USB PHY INTERFACE

- **USBDN_DP1** (pin 2): This pin is the positive (+) signal of the downstream Port 1 USB2.0 differential pair. All necessary USB terminations and resistors are included in the IC. This pin can connect directly to the D+/DP pin of a USB Connector.
- **USBDN_DM1** (pin 1): This pin is the negative (-) signal of the downstream Port 1 USB2.0 differential pair. All necessary USB terminations and resistors are included in the IC. This pin can connect directly to the D-/DM pin of a USB Connector.
- **USBDN_DP2** (pin 4): This pin is the positive (+) signal of the downstream Port 2 USB2.0 differential pair. All necessary USB terminations and resistors are included in the IC. This pin can connect directly to the D+/DP pin of an embedded device or second tier hub either directly on the PCB or through a permanently attached USB cable/wiring harness. This should not be wired to a user-accessible USB port.

USB2641

- **USBDN_DM1** (pin 1): This pin is the negative (–) signal of the downstream Port 2 USB2.0 differential pair. All necessary USB terminations and resistors are included in the IC. This pin can connect directly to the D+/DP pin of an embedded device or second tier hub either directly on the PCB or through a permanently attached USB cable/wiring harness. This should not be wired to a user-accessible USB port.

Note: The polarity of any of the USB2.0 differential pairs may be inverted either intentionally due to design constraints or to correct a design error using the Microchip PortSwap feature. This feature may be configured via SMBus/I²C configuration registers.

For transmit and receive channel connection details, refer to [Figure 4-2](#).

FIGURE 4-2: USB DOWNSTREAM PORT DATA SIGNAL CONNECTIONS

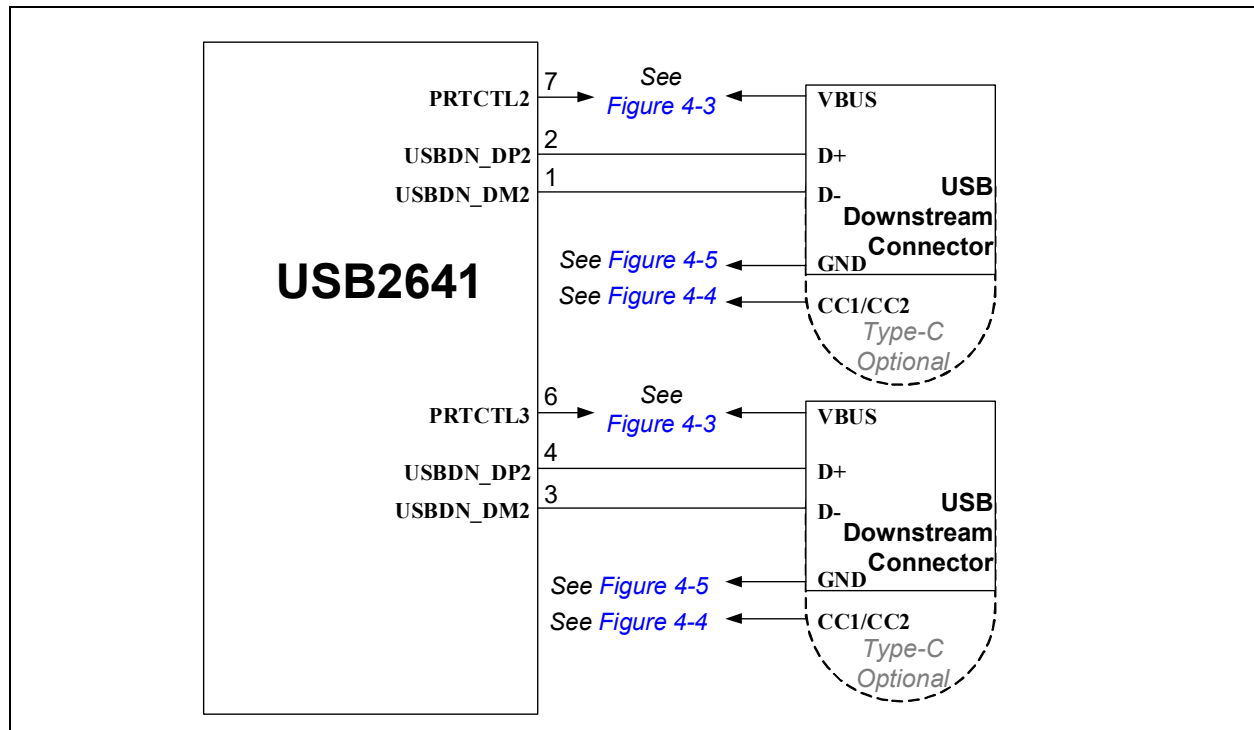

4.2.2 DISABLE DOWNSTREAM PORTS IF UNUSED

If any downstream of the USB2641 is unused, it should be disabled. This can be achieved through hub configuration (I2C), or through a port disable strap option.

4.2.3 DOWNSTREAM PORT CONTROL SIGNALS (PRTCTLX)

The **PRTCTLx** pin is an output pin which has the following states:

- **PORT OFF:** **PRTCTLx** is an output and drives low. The **PRTCTLx** pin will only transition to the PORT ON state through a specific command from the USB host.
- **PORT ON:** **PRTCTLx** enables internal pull-up resistor and switches to Input mode. While in this state, the input buffer monitors for overcurrent events. An overcurrent event is detected if the state of the pin is detected as low (below the V_{IL} voltage). The port moves to the PORT OFF state after one of the following events:
 - An overcurrent event is sensed when the state of the pin is detected as low (below the V_{IL} voltage).
 - A command from the USB host is received which instructs the hub to disable power.
 - The hub is reset or experiences a POR event.

To ensure minimal BOM cost and simplicity, select a port power controller device with a 3.3V logic level, active-high enable input, and an open-drain, active-low FAULT indication output signal. If a device which operates from a 5V logic level is selected, the **PRTCTLx** signal may need to be boosted using external logic. If a port power controller with an active-low input is selected, the **PRTCTLx** signal needs to be inverted using external logic.

A typical VBUS port power control implementation is shown in [Figure 4-3](#).

FIGURE 4-3: DOWNSTREAM VBUS AND PRTCTL1 CONNECTIONS

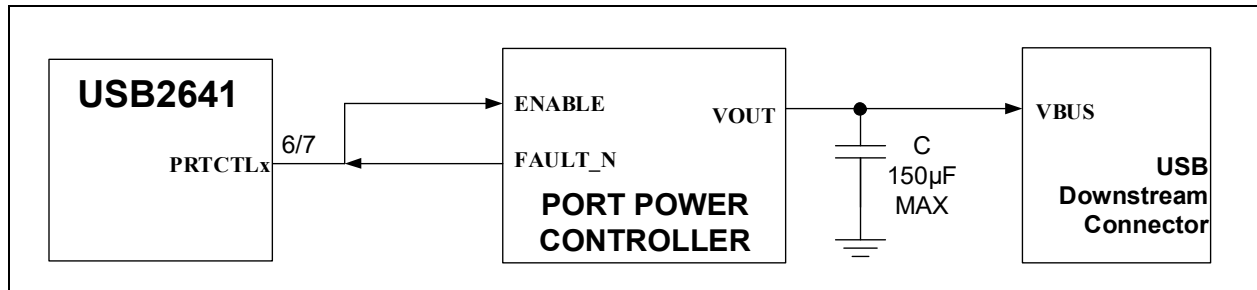

Note: The implementation, as shown in [Figure 4-3](#), assumes that the port power controller has an active-high enable input, and an active-low, open-drain style FAULT indicator. External polarity inversion through buffers or FETs may be required if the port power controller has different I/O characteristics.

4.2.4 DOWNSTREAM PORT TYPE-C SUPPORT

The USB2641 may be used with Type-C as the downstream port. This requires a Type-C port controller or combined port power controller and Type-C port controller. The USB2641 simply controls the Type-C port controller in the same way as it would control a standard Type-A port power controller. The USB2641 does not require any kind of Type-C port status information from the Type-C port controller. The **PRTCTLx** signal should be connected to an enable pin on the Type-C controller and the FAULT indicator output of the port power controller should also connect back to the **PRTCTLx** signal.

If the Type-C controller and the port power controller are separate devices, the Type-C controller must control the enable pin of the port power controller switch supplying VBUS to the connection. The **PRTCTLx** should not directly control the VBUS enable signal of the port power controller.

A Type-C controller may be configured to signal a 500 mA, 1.5A, or 3.0A port power capability. (However, per the USB specification, Type-C ports may not advertise a 500 mA capability. That power level is reserved for legacy port cable adapters alone). The selected port power controller should be sized accordingly.

Note: It is not possible to implement a USB Type-C[®] downstream port that is compliant to all USB Type-C specification without utilizing a Type-C port controller device. The required functionality is not practical to achieve solely using discrete analog circuitry.

USB2641

A typical implementation is shown in [Figure 4-4](#).

FIGURE 4-4: DOWNSTREAM VBUS AND PRTCTL1 CONNECTIONS WITH A TYPE-C PORT

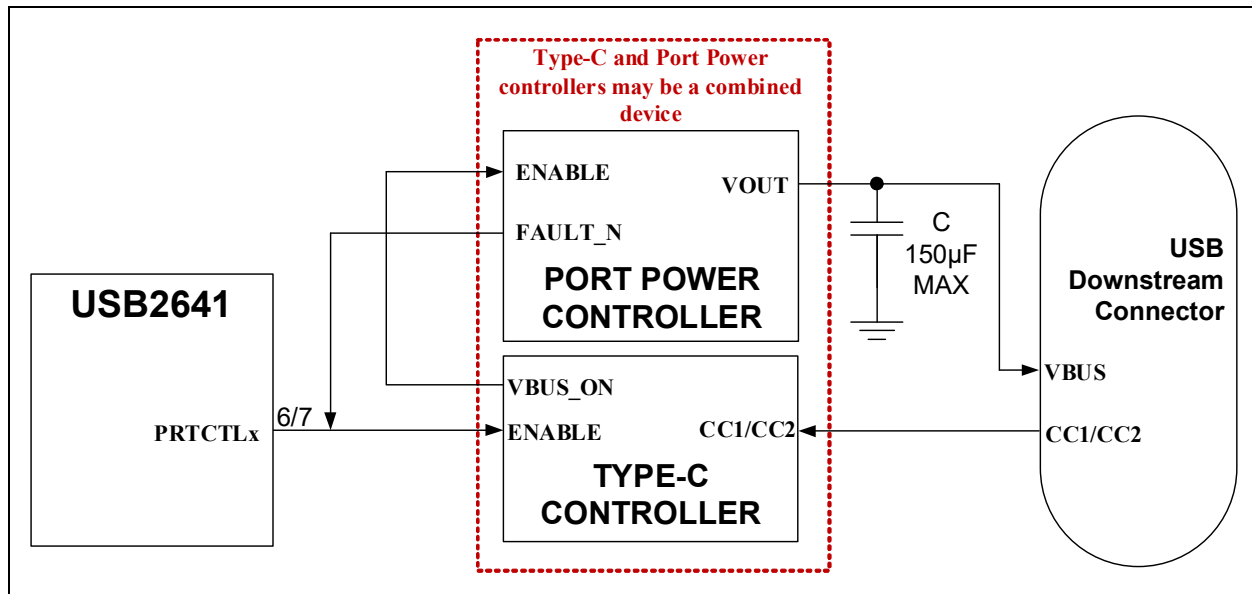

Note: The implementation, as shown in [Figure 4-4](#), assumes that the Type-C controller has an active-high enable input, and the port power controller has an active-low, open-drain style FAULT indicator. External polarity inversion through buffers or FETs may be required if the Type-C controller and/or port power controller has different I/O characteristics.

4.3 USB Protection

The use of external protection circuitry may be required to provide additional ESD protection beyond what is included in the hub IC. These generally are grouped into three categories:

1. TVS protection diodes
 - ESD protection for IEC-61000-4-2 system level tests
2. Application targeted protection ICs or galvanic isolation devices
 - DC overvoltage protection for short to battery protection
3. Common-mode chokes
 - For EMI reduction

The USB2641 can be used in conjunction with these types of devices, but it is important to understand the negative effect on USB signal integrity that these devices may have and to select components accordingly and follow the implementation guidelines from the manufacturer of these devices. You may also use the following general guidelines for implementing these devices:

- Select only devices that are designed specifically for high-speed applications. Per the USB specification, a total of 5 pF is budgeted for connector, PCB traces, and protection circuitry.
- These devices should be placed as close to the USB connector as possible.
- Never branch the USB signals to reach protection devices. Always place the protection devices directly on top of the USB differential traces.
- The effectiveness of TVS devices depends heavily on effective grounding. Always ensure a very low impedance path to a large ground plane.
- Place TVS diodes on the same layer as the USB signal trace. Avoid vias or place vias behind the TVS device if possible.

Note: Microchip PHYBoost configuration options are available for compensating the negative effects of these devices. This feature may help overcome marginal failures. It is simplest to determine the appropriate setting using laboratory experiments, such as USB eye diagram tests, on physical hardware.

4.4 GND and SHIELD Recommendations

The **GND** pins of the USB connector must be connected to the PCB with a low impedance path directly to a large **GND** plane.

The **SHIELD** pins of the USB connector may be connected in one of two ways:

1. [Recommended] To **GND** through an resistor and capacitor in parallel. An RC filter can help to decouple and minimize EMI between a PCB and a USB cable.
2. Directly to the **GND** plane.

The recommended implementation is shown in [Figure 4-5](#).

FIGURE 4-5: RECOMMENDED USB CONNECTOR GND AND SHIELD CONNECTIONS

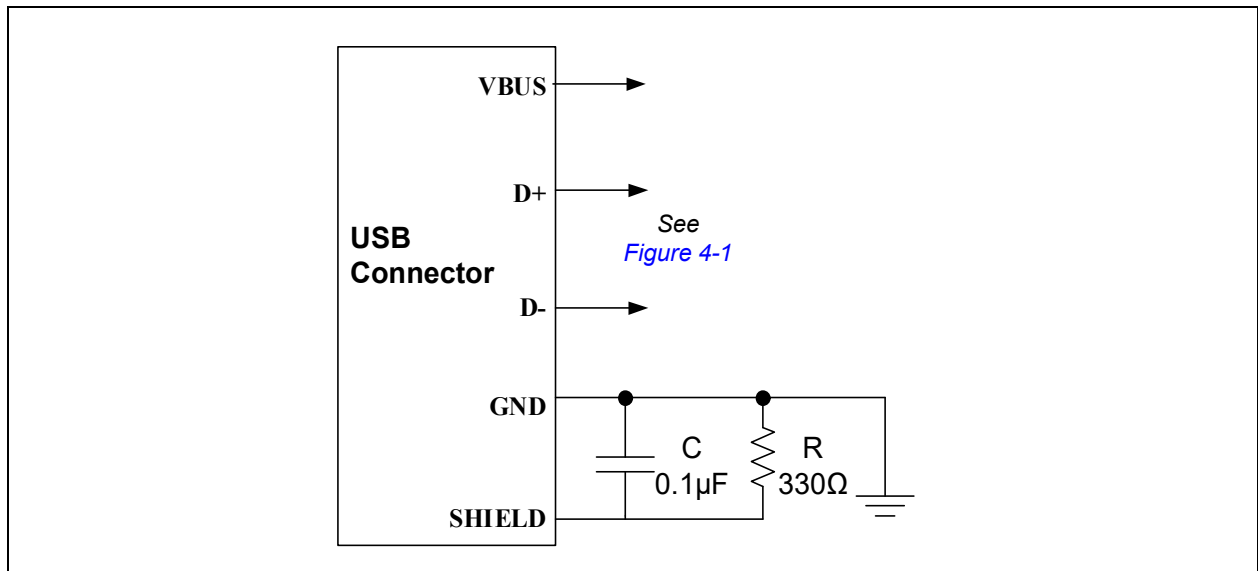

USB2641

5.0 CARD READER INTERFACE

5.1 Secure Digital/Multi-MediaCard Slot

- The USB2641 supports Secure Digital (SD) 2.0, including HS-SD and SDHC media. Newer media and small-form-factor SD media (i.e. microSD) are also supported due to backward compatibility requirements on all compliant SD media although newer features and performance cannot be taken advantage of.
- 1/4/8-bit MultiMediaCard™ (MMC) 4.2 is also supported on the same interface and card slot. Newer MMC media and eMMC media is also supported due to backward compatibility requirements on all compliant MMC media although newer features and performance cannot be taken advantage of.
- If designing with a standard SD/MMC card slot, refer to [Figure 5-1](#).
- If designing with an embedded eMMC memory, refer to [Figure 5-2](#).
- If designing with a microSD card slot, refer to [Figure 5-3](#).

FIGURE 5-1: SD/MMC MEDIA SLOT

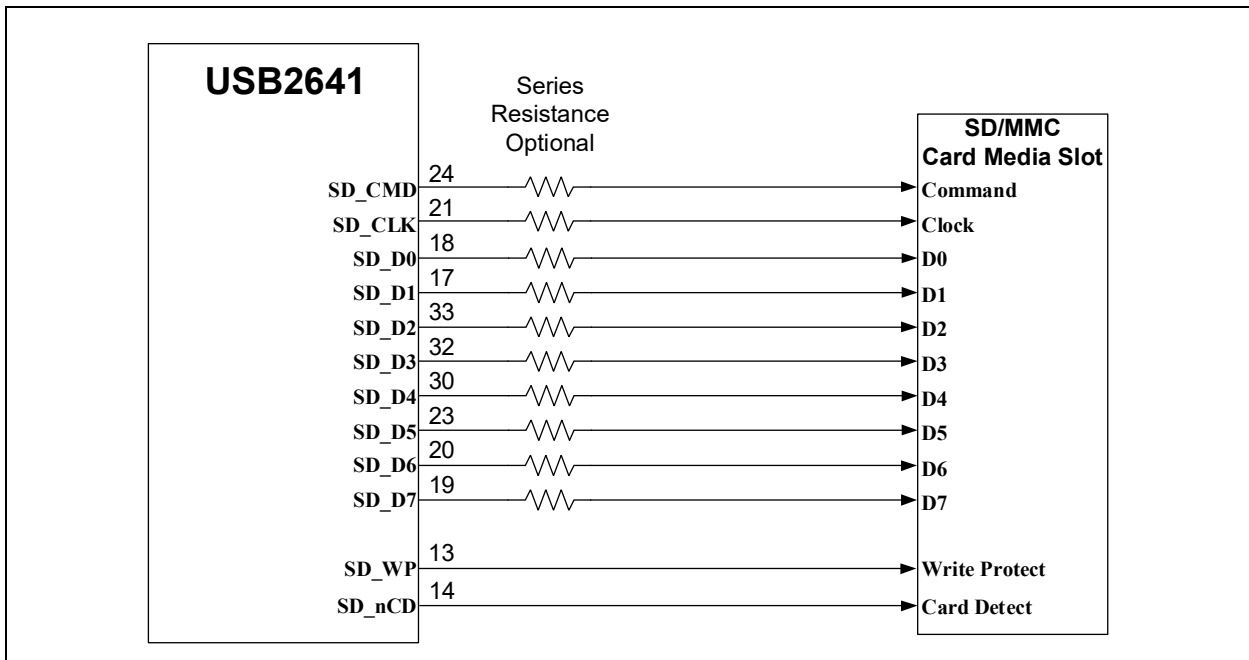
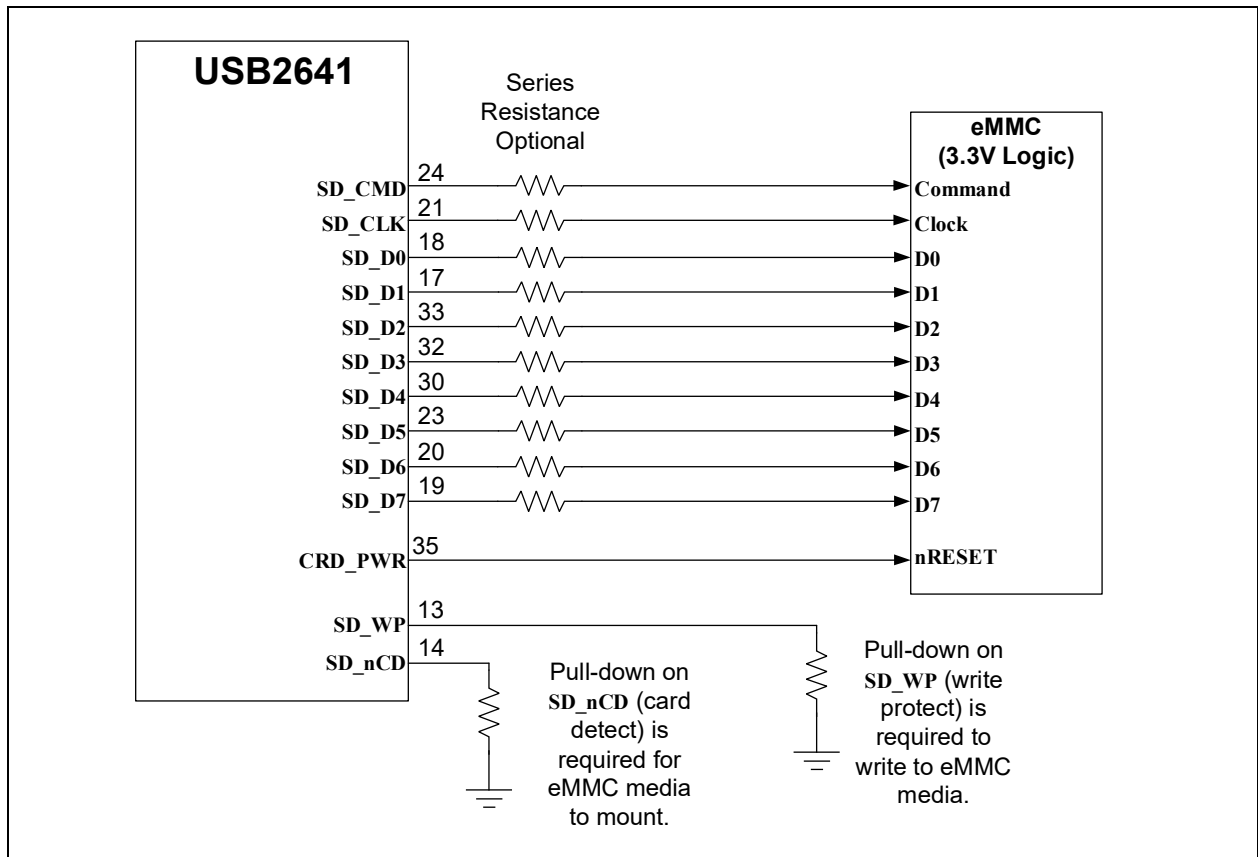
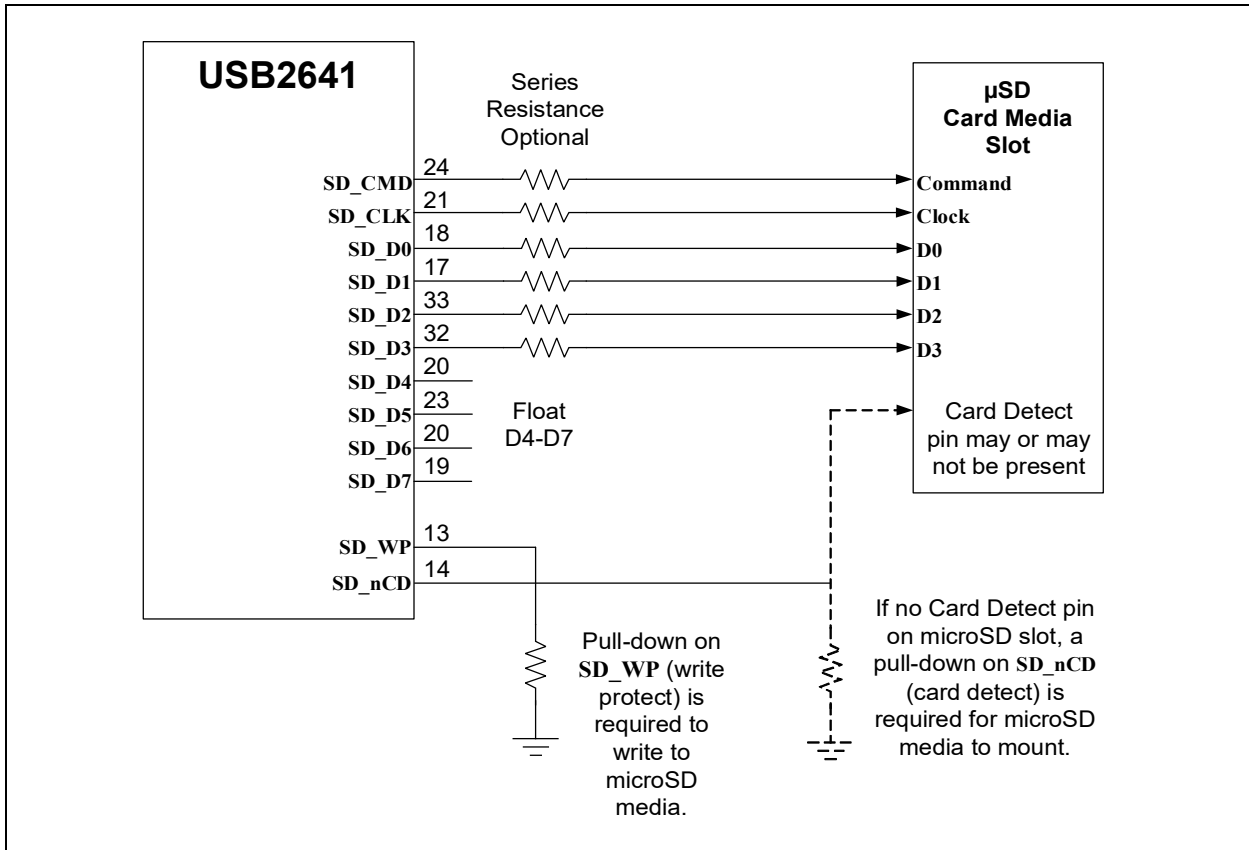

FIGURE 5-2: EMMC (EMBEDDED MMC) MEMORY CONNECTIONS



USB2641

FIGURE 5-3: MICROSD CARD SLOT CONNECTIONS



5.2 Card Power Switch

The USB2641 includes an internal 3.3V power switch on **CRD_PWR** capable of supplying up to 200 mA continuously to the attached media. The card power switch includes **FAULT** protection and will automatically shut off the output if current draw exceeds the 200 mA maximum.

Note: The default setting for card power current limit is 200 mA. It may be optionally set to 100 mA via EEPROM configuration if desired.

The card power output should include some bulk capacitance to maintain voltage stability during card use. A 4.7 μF ceramic capacitor is sufficient for most-use cases. Certain high-power media may require more. Smaller capacitances can also be added to filter out high-frequency noise if present in the system.

An LED may be optionally connected directly to the card power output to give visual indication of card power.

FIGURE 5-4: CRD_PWR CARD MEDIA POWER SUPPLY SWITCH

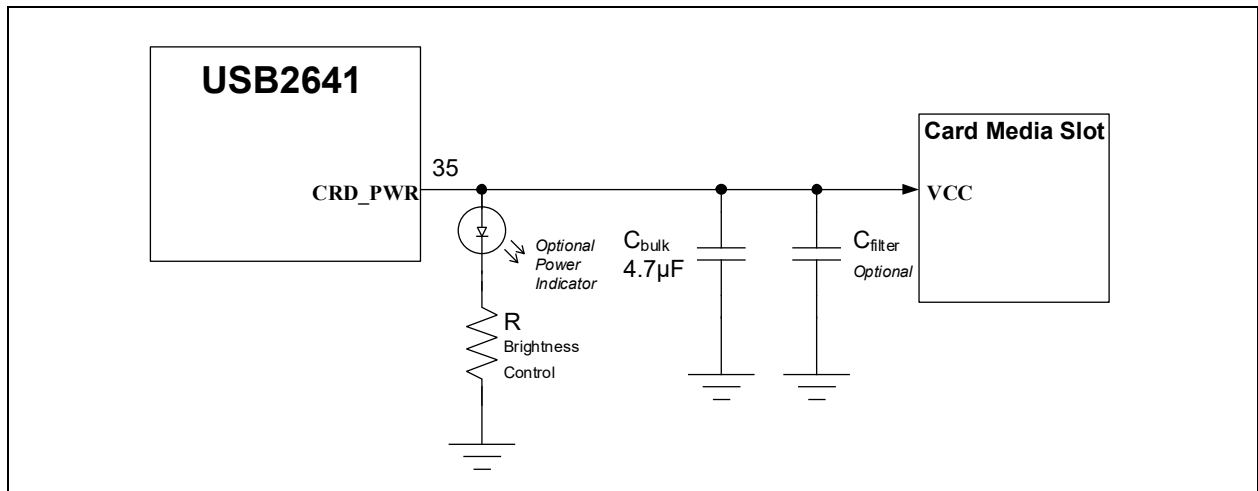

If the internal card power switch is not used, it is still recommended to use the CRD_PWR pin to control the supply to the card media slot. This allows the internal logic of the USB2641 to reset power to the card during error recovery attempts.

FIGURE 5-5: EXTERNAL CARD POWER SUPPLY SWITCH RECOMMENDED CONNECTIONS

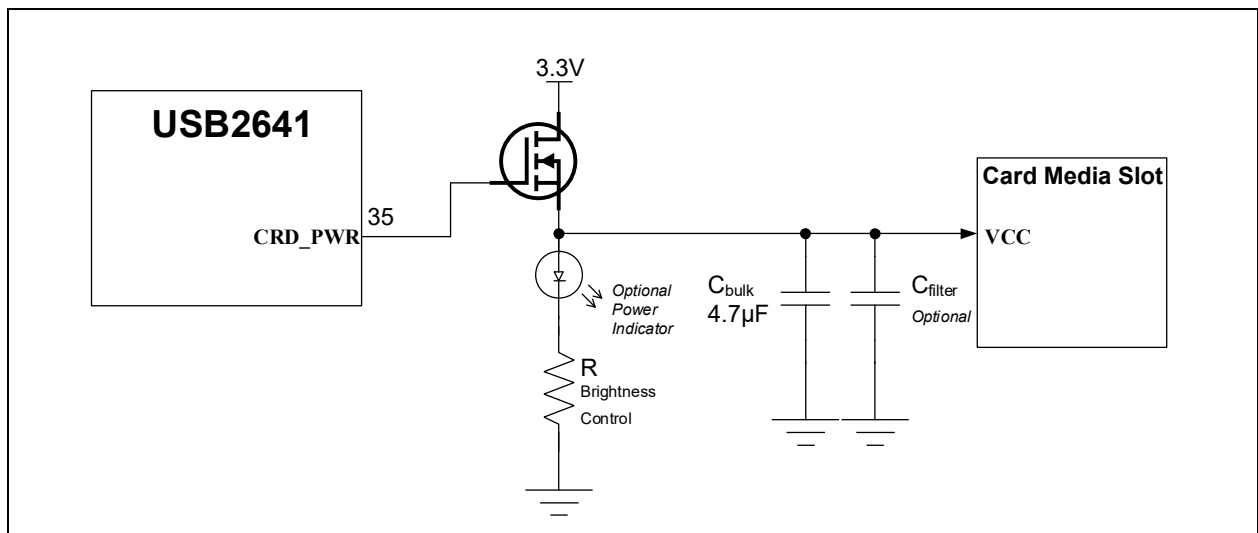

USB2641

6.0 CLOCK CIRCUIT

6.1 Crystal and External Clock Connection

A 24.000-MHz (± 350 ppm) reference clock is the source for the USB interface and for all other functions of the device. For exact specifications and tolerances, refer to the latest revision of the *USB2641 Data Sheet*.

- **XTAL1(CLKIN)** (pin 45) is the clock circuit input for the USB2641. This pin requires a capacitor to ground. One side of the crystal connects to this pin.
- **XTAL2** (pin 44) is the clock circuit output for the USB2641. This pin requires a capacitor to ground. One side of the crystal connects to this pin.
- A 1 megohm resistor ($1\text{ M}\Omega$) is required connected across the **XTAL1** and **XTAL2** pins.
- The crystal loading capacitor values are system dependent, based on the total C_L specification of the crystal and the stray capacitance value. The PCB design, crystal, and layout all contribute to the characteristics of this circuit. A commonly used formula for calculating the appropriate physical C_1 and C_2 capacitor values is:
 - $C_L = ((C_{X1})(C_{X2}) / (C_{X1} + C_{X2}))$
 - Where: C_L is the specification from the crystal data sheet, $C_{X1} = C_{\text{stray}} + C_1$, $C_{X2} = C_{\text{stray}} + C_2$.
 - Note that C_{stray} is the stray/parasitic capacitance due to PCB layout. It can be assumed to be very small, within the 1 pF to 2 pF range, and then verified by physical experiments in the laboratory if PCB simulation tools are not available.
- Alternately, a 24.000 MHz, 1.2-to-3.3V clock oscillator may be supplied to **XTAL1(CLKIN)** to provide the clock source for the USB2641. When using a single ended clock source, **XTAL2** (pin 44) should be left floating as a No Connect (NC).

FIGURE 6-1: CRYSTAL AND OSCILLATOR CONNECTIONS

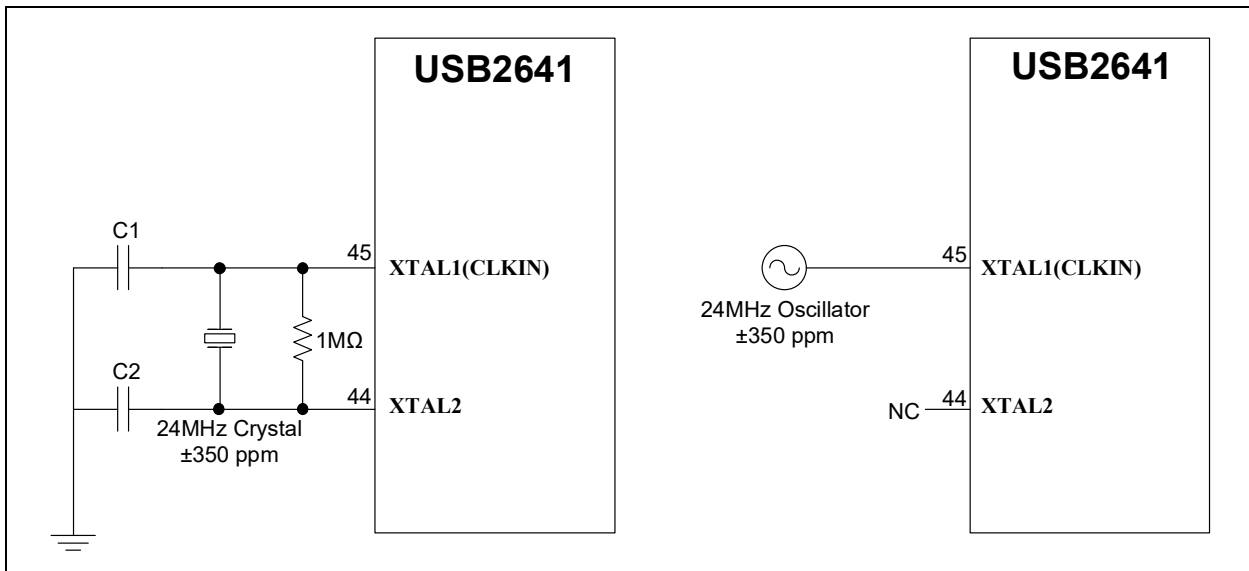

7.0 POWER AND STARTUP

7.1 RBIAS Resistor

RBIAS (pin 47) on the USB2641 must connect to ground through a 12 k Ω resistor with a tolerance of 1.0%. This is used to set up critical bias currents for the internal circuitry. This should be placed as close to the IC pin as possible, and be given a dedicated, low-impedance path to a ground plane.

7.2 Board Power Supplies

7.2.1 POWER RISE TIME

The power rail voltage and rise time should adhere to the supply rise time specification as defined in the *USB2641 Data Sheet*.

If a monotonic or fast power rail rise cannot be assured, then the **RESET_N** signal should be controlled by a Reset supervisor and only released when the power rail has reached a stable level.

7.2.2 CURRENT CAPABILITY

It is important to size the 3.3V power rails appropriately. The 3.3V power supply must be capable of supplying sufficient power for the USB2641 (up to 330 mA at 3.3V) as well as the card media supported (up to 200 mA if using the internal card power supply output on **CRD_PWR**).

7.3 Reset Circuit

RESET_N (pin 38) is an active-low Reset input. This signal resets all logic and registers within the USB2641. A hardware Reset (**RESET_N** assertion) is not required following power-up. Please refer to the latest copy of the *USB2641 Data Sheet* for Reset timing requirements. [Figure 7-1](#) shows a recommended Reset circuit for powering up the USB2641 when Reset is triggered by the power supply. The values for the “R” resistor and “C” capacitor are not critical and may be adjusted per individual system needs or preferences.

FIGURE 7-1: RESET TRIGGERED BY POWER SUPPLY

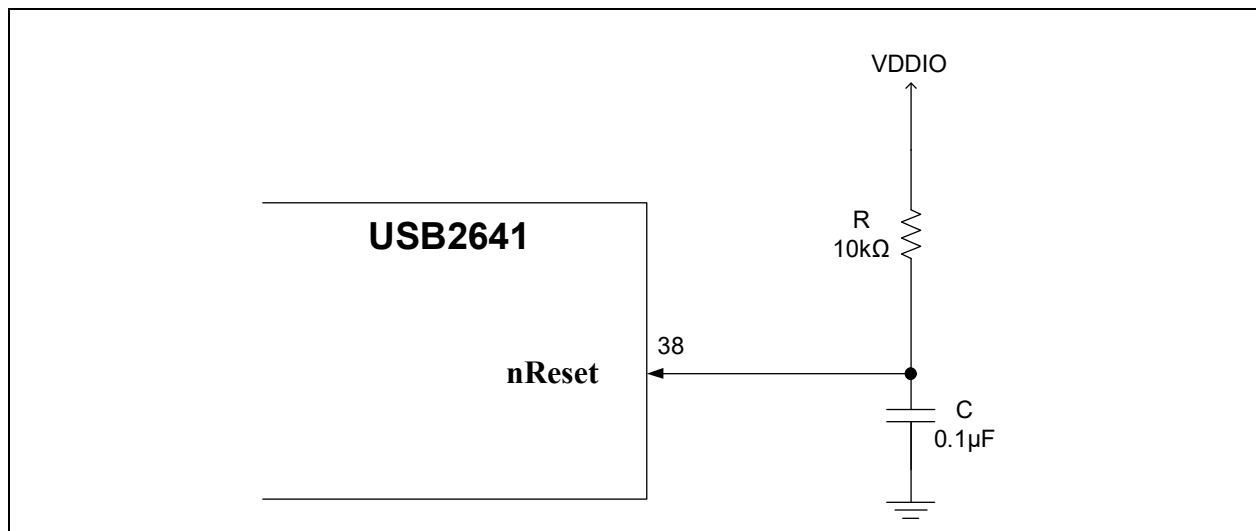

USB2641

Figure 7-2 details the recommended Reset circuit for applications where Reset is driven by an external CPU/MCU. The Reset out pin (RST_OUT_N) from the CPU/MCU provides the warm Reset after power-up. The values for the “R” resistor and “C” capacitor are not critical and may be adjusted to individual system needs or preferences.

FIGURE 7-2: RESET CIRCUIT INTERFACE WITH CPU/MCU RESET OUTPUT

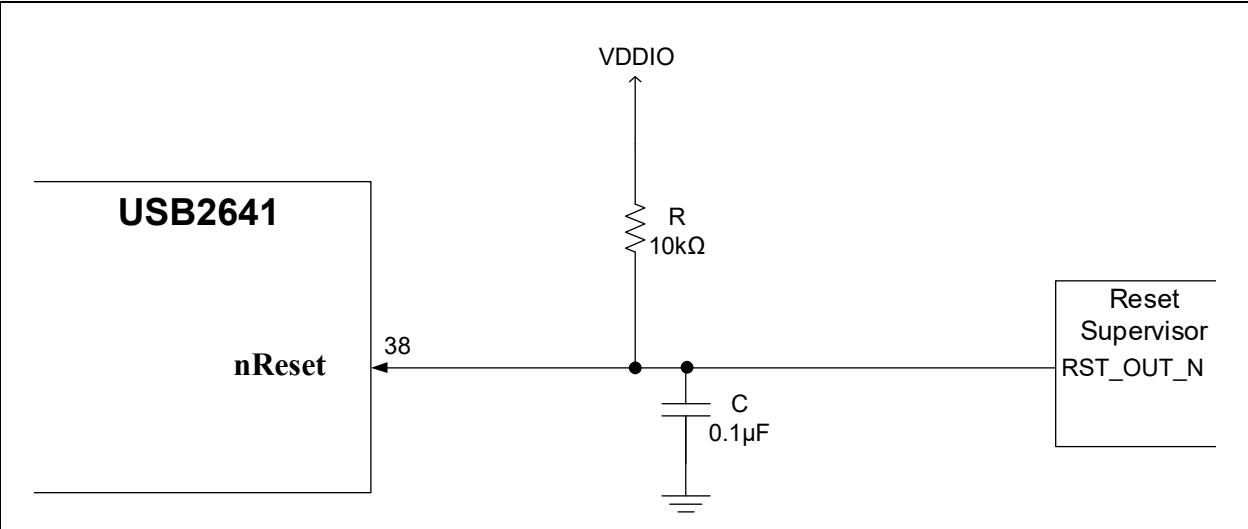

8.0 CONFIGURATION OPTIONS

The USB2641 can be configured to allow for customizable vendor, product, and device IDs, serial number, product string descriptors, and more from either of the following methods:

- I2C 512 Byte (512x8) EEPROM memory device
- SPI interface executing a new firmware image in place

8.1 External EEPROM

An external EEPROM is not required for USB2641 operation—internal defaults may be used for many applications. If the external EEPROM is not detected at boot, internal defaults will be loaded. See [Figure 8-1](#).

FIGURE 8-1: EEPROM CONNECTIONS

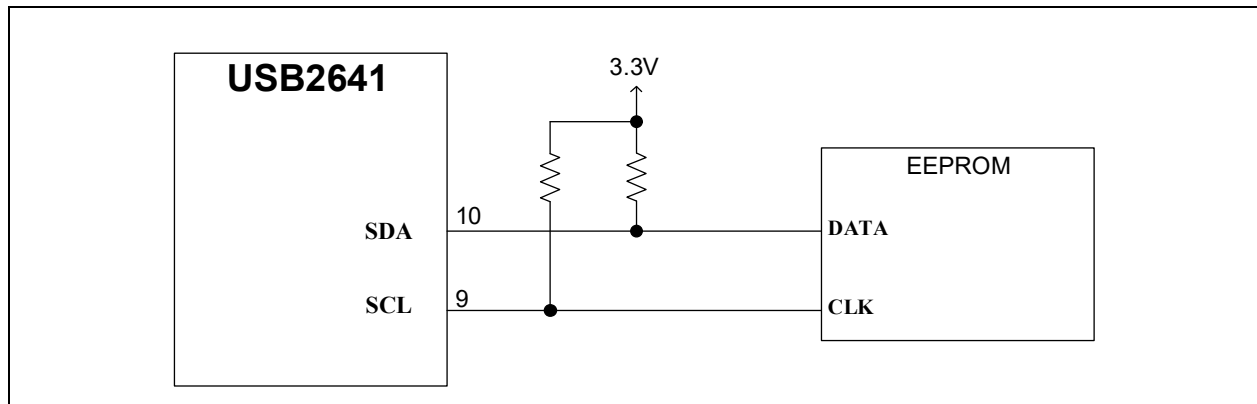

8.2 External SPI Flash memory

For custom applications, an external SPI Flash may be used to execute a unique firmware image. In most applications, this functionality is not used.

By default, the USB2641 executes firmware from an internal read only memory (ROM). The USB2641 supports optional firmware execution from an external SPI Flash device. An SPI Flash is only required if a custom firmware is required for the application.

The following are the key operational parameters:

- The SPI interface can operate at 60 MHz or 30 MHz. The speed is selected by the `SPI_SPD_SEL` hardware configuration strap.
- The SPI interface can operate in One-bit or Two-bit mode.
- Mode 0 or Mode 3 SPI Flash memory devices are supported.
- Generally, a 256 kB or larger memory size is required, but the final size is determined by the size of the custom firmware image after all customizations are implemented.

USB2641

If an external SPI Flash device is used, the recommended schematic connections are shown in Figure 8-2.

FIGURE 8-2: DUAL SPI FLASH CONNECTIONS

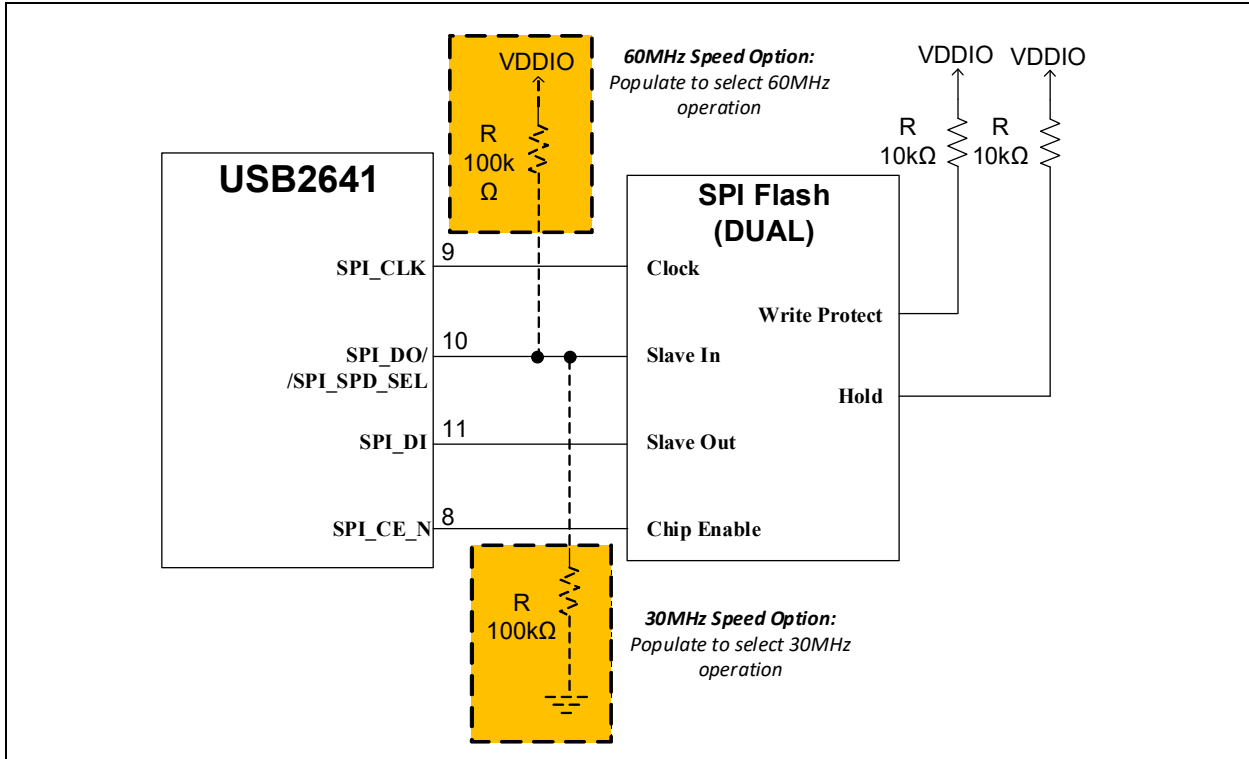

8.3 Non-Removable Port Settings

In a typical USB2641 application, downstream ports are routed to a user-accessible USB connector and, hence, the downstream port should be configured as a removable port. By default, all downstream ports are configured as removable ports. If modifying the default settings to reconfigure a port as non-removable, configuration must be handled through either external EEPROM or SPI Flash.

The following guidelines can be used to determine which setting to use:

- If the port is routed to a user-accessible USB connector, it is **removable**.
- If the port is routed to a permanently attached and embedded USB device on the same PCB, or non user-accessible wiring or cable harness, it is **non-removable**.

Note: The removable/non-removable device settings do not impact the operation of the hub in any way. The settings only modify select USB descriptors which the USB host may use to understand if a port is a user-accessible port or if the device is a permanently attached device. Under standard operating conditions, the USB host may or may not modify its operation based upon this information. Certain USB compliance tests are impacted by this setting, so designs which must undergo USB compliance testing and certification must ensure the configuration settings are correct.

8.4 Self-Powered/Bus-Powered Settings

In a typical USB2641 application, the hub should be configured as self-powered, which is the default configuration setting. If modifying the default setting to bus-powered operation, configuration must be handled through either external EEPROM or SPI Flash.

The following guidelines can be used to determine which setting to use:

- If the entire system (hub included) is powered completely from the Upstream USB connector's VBUS pin and the system is designed to operate using standard USB cabling and any standard USB host, then the hub system is **bus-powered**.

- If the entire system (hub included) is always powered by a separate power connector, then the hub system is **self-powered**.
- If the hub included is part of a larger embedded system with fixed cabling and a fixed USB host, then the hub system is most likely **self-powered** (even if all of the power is derived from the upstream USB connector's **VBUS** pin).

Note: The self-powered/bus-powered device settings do not impact the operation of the hub in any way. The settings only modify select USB descriptors which the USB host will use to budget power accordingly. Since a standard USB2.0 port is required to supply 500 mA to the downstream port, a self-powered hub, and all of its downstream ports must continue to operate within that 500 mA budget. A USB host will typically limit the downstream ports of a self-powered hub to 100 mA. Any device which connects to a self-powered hub which declares it needs more than 100 mA will be prevented from operating by the USB host.

USB2641

NOTES:

9.0 HARDWARE CHECKLIST SUMMARY

TABLE 9-1: HARDWARE DESIGN CHECKLIST

Section	Check	Explanation	√	Notes
Section 2.0, "General Considerations"	Section 2.1, "Required References"	All necessary documents are on hand.		
	Section 2.2, "Pin Check"	The pins match the data sheet.		
	Section 2.3, "Ground"	The grounds are tied together.		
	Section 2.4, "USB-IF Compliant USB Connector"	USB-IF-compliant USB connectors with an assigned TID are used in the design (if USB compliance is required for the design).		
Section 3.0, "Power"		The VDD33 and VDDA33 are within the range of 3.0V to 3.6V. 0.1 μ F capacitors are connected to each power pin as close as possible, along with a 1.0 μ F shared capacitor.		
		Ensure VDDA33 (pin 48) has a 4.7 μ F capacitor to GND.		
		Ensure VDD33 (pin 16) has a 4.7 μ F capacitor to GND.		
		Ensure VDD18 (pin 15) and VDDA18 (pin 46) each have a 1.0 μ F capacitor to GND.		
		Ensure VREG_EN is floating unless VDD18 is being sourced from an external regulator.		
Section 4.0, "USB Signals"	Section 4.1, "Upstream USB Interface"	The USB data pins are correctly routed to the USB connectors. Pay special attention to the polarity of the USB2.0 D+ and D- data lines.		
		The VBUS_DET is properly connected, and the voltage is divided from nominal 5V VBUS to the 3.3V logic level the hub requires.		
	Section 4.2, "Downstream USB Ports"	Verify that the downstream port USB data pins are correctly routed to the USB connectors. Pay special attention to the polarity of the USB2.0 D+ and D- data lines.		
		If the downstream ports are standard Type-A ports, verify that PRT_CTLx is properly connected to both the Enable pin of the downstream port power controller and the FAULT indicator output of the port power controller.		
	If the downstream ports are standard Type-C ports, verify that PRT_CTLx is properly connected to both the Enable pin of the downstream port power controller and the FAULT indicator output of the port power controller.			

TABLE 9-1: HARDWARE DESIGN CHECKLIST (CONTINUED)

Section	Check	Explanation	√	Notes
	Section 4.3, "USB Protection"	The ESD/EMI protection devices are designed specifically for high-speed data applications and that the combined parasitic capacitance, the protection devices, USB traces, and USB connector do not exceed 5 pF on each USB trace.		
	Section 4.4, "GND and SHIELD Recommendations"	The USB connector is properly connected to PCB ground on both the GND pins and the SHIELD pins. It is recommended that an RC filter be placed in between the SHIELD pins and PCB ground.		
Section 5.0, "Card Reader Interface"	Section 5.1, "Secure Digital/Multi-Media Card Slot"	All connections to a standard SD/MMC card slot, embedded eMMC memory, or microSD card slot are correct. Follow the diagrams in Figure 5-1 , Figure 5-2 , or Figure 5-4 .		
	Section 5.2, "Card Power Switch"	The CRD_PWR either connects directly to the card media or card media slot supply power, or CRD_PWR enables an external supply switch if the internal card power switch is not used directly.		
Section 6.0, "Clock Circuit"	Section 6.1, "Crystal and External Clock Connection"	The crystal or clock is 24.000 MHz (± 350 ppm).		
		If a single-ended clock is used, it is connected to XTAL1 while leaving XTAL2 floating.		
		If a crystal is used, ensure the loading capacitors are appropriately sized for the crystal loading requirement.		
Section 7.0, "Power and Startup"	Section 7.1, "RBIAS Resistor"	A 12.0 k Ω 1% resistor is connected between the RBIAS pin and PCB ground.		
	Section 7.2, "Board Power Supplies"	The board power supplies deliver 3.0V to 3.6V to the hub power rails, and the power-on rise time meets the requirement of the hub as defined in the data sheet.		
		If the rise time requirement cannot be met, the RESET_N line is held low until the power regulators reach a steady state.		
	Section 7.3, "Reset Circuit"	The RESET_N signal has an external pull-up resistor or is otherwise properly controlled by an external SOC, MCU, or Reset supervisor device.		

TABLE 9-1: HARDWARE DESIGN CHECKLIST (CONTINUED)

Section	Check	Explanation	√	Notes
Section 8.0, "Configuration Options"	Section 8.1, "External EEPROM"	If a EEPROM memory device is used, verify that the EEPROM is connected according to the diagram in Figure 8-1 .		
	Section 8.2, "External SPI Flash memory"	Determine if a custom SPI FW image is required and which mode of operation the selected SPI Flash device must support. If a SPI Flash memory device is used, verify that the SPI Flash is connected according to the diagram in Figure 8-2 .		
	Section 8.3, "Non-Removable Port Settings"	Verify the application requirements for removable and non-removable USB downstream ports.		
		If any port must be configured as non-removable, then the hub must be configured via EEPROM or SPI Flash.		
Section 8.4, "Self-Powered/Bus-Powered Settings"	Refer to this section for application requirements for self-powered or bus-powered operation. If self-powered operation is required, then no additional configuration or circuitry is required. If bus-powered operation is required, then the hub must be configured via EEPROM or SPI Flash.			

USB2641

APPENDIX A: REVISION HISTORY

TABLE A-1: REVISION HISTORY

Revision Level & Date	Section/Figure/Entry	Correction
DS00004546A (05-20-22)	Initial release	

NOTES:

USB2641

THE MICROCHIP WEB SITE

Microchip provides online support via our WWW site at www.microchip.com. This web site is used as a means to make files and information easily available to customers. Accessible by using your favorite Internet browser, the web site contains the following information:

- **Product Support** – Data sheets and errata, application notes and sample programs, design resources, user's guides and hardware support documents, latest software releases and archived software
- **General Technical Support** – Frequently Asked Questions (FAQ), technical support requests, online discussion groups, Microchip consultant program member listing
- **Business of Microchip** – Product selector and ordering guides, latest Microchip press releases, listing of seminars and events, listings of Microchip sales offices, distributors and factory representatives

CUSTOMER CHANGE NOTIFICATION SERVICE

Microchip's customer notification service helps keep customers current on Microchip products. Subscribers will receive e-mail notification whenever there are changes, updates, revisions or errata related to a specified product family or development tool of interest.

To register, access the Microchip web site at www.microchip.com. Under "Support", click on "Customer Change Notification" and follow the registration instructions.

CUSTOMER SUPPORT

Users of Microchip products can receive assistance through several channels:

- Distributor or Representative
- Local Sales Office
- Field Application Engineer (FAE)
- Technical Support

Customers should contact their distributor, representative or Field Application Engineer (FAE) for support. Local sales offices are also available to help customers. A listing of sales offices and locations is included in the back of this document.

Technical support is available through the web site at: <http://microchip.com/support>

Note the following details of the code protection feature on Microchip products:

- Microchip products meet the specifications contained in their particular Microchip Data Sheet.
- Microchip believes that its family of products is secure when used in the intended manner, within operating specifications, and under normal conditions.
- Microchip values and aggressively protects its intellectual property rights. Attempts to breach the code protection features of Microchip product is strictly prohibited and may violate the Digital Millennium Copyright Act.
- Neither Microchip nor any other semiconductor manufacturer can guarantee the security of its code. Code protection does not mean that we are guaranteeing the product is “unbreakable”. Code protection is constantly evolving. Microchip is committed to continuously improving the code protection features of our products.

This publication and the information herein may be used only with Microchip products, including to design, test, and integrate Microchip products with your application. Use of this information in any other manner violates these terms. Information regarding device applications is provided only for your convenience and may be superseded by updates. It is your responsibility to ensure that your application meets with your specifications. Contact your local Microchip sales office for additional support or, obtain additional support at <https://www.microchip.com/en-us/support/design-help/client-support-services>.

THIS INFORMATION IS PROVIDED BY MICROCHIP "AS IS". MICROCHIP MAKES NO REPRESENTATIONS OR WARRANTIES OF ANY KIND WHETHER EXPRESS OR IMPLIED, WRITTEN OR ORAL, STATUTORY OR OTHERWISE, RELATED TO THE INFORMATION INCLUDING BUT NOT LIMITED TO ANY IMPLIED WARRANTIES OF NON-INFRINGEMENT, MERCHANTABILITY, AND FITNESS FOR A PARTICULAR PURPOSE, OR WARRANTIES RELATED TO ITS CONDITION, QUALITY, OR PERFORMANCE.

IN NO EVENT WILL MICROCHIP BE LIABLE FOR ANY INDIRECT, SPECIAL, PUNITIVE, INCIDENTAL, OR CONSEQUENTIAL LOSS, DAMAGE, COST, OR EXPENSE OF ANY KIND WHATSOEVER RELATED TO THE INFORMATION OR ITS USE, HOWEVER CAUSED, EVEN IF MICROCHIP HAS BEEN ADVISED OF THE POSSIBILITY OR THE DAMAGES ARE FORESEEABLE. TO THE FULLEST EXTENT ALLOWED BY LAW, MICROCHIP'S TOTAL LIABILITY ON ALL CLAIMS IN ANY WAY RELATED TO THE INFORMATION OR ITS USE WILL NOT EXCEED THE AMOUNT OF FEES, IF ANY, THAT YOU HAVE PAID DIRECTLY TO MICROCHIP FOR THE INFORMATION.

Use of Microchip devices in life support and/or safety applications is entirely at the buyer's risk, and the buyer agrees to defend, indemnify and hold harmless Microchip from any and all damages, claims, suits, or expenses resulting from such use. No licenses are conveyed, implicitly or otherwise, under any Microchip intellectual property rights unless otherwise stated.

Trademarks

The Microchip name and logo, the Microchip logo, Adaptec, AnyRate, AVR, AVR logo, AVR Freaks, BesTime, BitCloud, CryptoMemory, CryptoRF, dsPIC, flexPWR, HELDO, IGLOO, JukeBlox, KeeLoq, Klear, LANCheck, LinkMD, maXStylus, maXTouch, MediaLB, megaAVR, Microsemi, Microsemi logo, MOST, MOST logo, MPLAB, OptoLyzer, PIC, picoPower, PICSTART, PIC32 logo, PolarFire, Prochip Designer, QTouch, SAM-BA, SenGenuity, SpyNIC, SST, SST Logo, SuperFlash, Symmetricom, SyncServer, Tachyon, TimeSource, tinyAVR, UNI/O, Vectron, and XMEGA are registered trademarks of Microchip Technology Incorporated in the U.S.A. and other countries.

AgileSwitch, APT, ClockWorks, The Embedded Control Solutions Company, EtherSynch, Flashtec, Hyper Speed Control, HyperLight Load, IntelliMOS, Libero, motorBench, mTouch, Powermite 3, Precision Edge, ProASIC, ProASIC Plus, ProASIC Plus logo, Quiet-Wire, SmartFusion, SyncWorld, Temux, TimeCesium, TimeHub, TimePictra, TimeProvider, TrueTime, WinPath, and ZL are registered trademarks of Microchip Technology Incorporated in the U.S.A.

Adjacent Key Suppression, AKS, Analog-for-the-Digital Age, Any Capacitor, AnyIn, AnyOut, Augmented Switching, BlueSky, BodyCom, CodeGuard, CryptoAuthentication, CryptoAutomotive, CryptoCompanion, CryptoController, dsPICDEM, dsPICDEM.net, Dynamic Average Matching, DAM, ECAN, Espresso T1S, EtherGREEN, GridTime, IdealBridge, In-Circuit Serial Programming, ICSP, INICnet, Intelligent Paralleling, Inter-Chip Connectivity, JitterBlocker, Knob-on-Display, maxCrypto, maxView, memBrain, Mindi, MiWi, MPASM, MPF, MPLAB Certified logo, MPLIB, MPLINK, MultiTRAK, NetDetach, NVM Express, NVMe, Omniscient Code Generation, PICDEM, PICDEM.net, PICkit, PICtail, PowerSmart, PureSilicon, QMatrix, REAL ICE, Ripple Blocker, RTAX, RTG4, SAM-ICE, Serial Quad I/O, simpleMAP, SimpliPHY, SmartBuffer, SmartHLS, SMART-I.S., storClad, SQI, SuperSwitcher, SuperSwitcher II, Switchtec, SynchroPHY, Total Endurance, TSHARC, USBCheck, VariSense, VectorBlox, VeriPHY, ViewSpan, WiperLock, XpressConnect, and ZENA are trademarks of Microchip Technology Incorporated in the U.S.A. and other countries.

SQTP is a service mark of Microchip Technology Incorporated in the U.S.A.

The Adaptec logo, Frequency on Demand, Silicon Storage Technology, Symmcom, and Trusted Time are registered trademarks of Microchip Technology Inc. in other countries.

GestIC is a registered trademark of Microchip Technology Germany II GmbH & Co. KG, a subsidiary of Microchip Technology Inc., in other countries.

All other trademarks mentioned herein are property of their respective companies.

© 2022, Microchip Technology Incorporated and its subsidiaries.

All Rights Reserved.

ISBN: 978-1-6683-0481-5

For information regarding Microchip's Quality Management Systems, please visit www.microchip.com/quality.



MICROCHIP

Worldwide Sales and Service

AMERICAS

Corporate Office
2355 West Chandler Blvd.
Chandler, AZ 85224-6199
Tel: 480-792-7200
Fax: 480-792-7277
Technical Support:
<http://www.microchip.com/support>
Web Address:
www.microchip.com

Atlanta

Duluth, GA
Tel: 678-957-9614
Fax: 678-957-1455

Austin, TX

Tel: 512-257-3370

Boston

Westborough, MA
Tel: 774-760-0087
Fax: 774-760-0088

Chicago

Itasca, IL
Tel: 630-285-0071
Fax: 630-285-0075

Dallas

Addison, TX
Tel: 972-818-7423
Fax: 972-818-2924

Detroit

Novi, MI
Tel: 248-848-4000

Houston, TX

Tel: 281-894-5983

Indianapolis

Noblesville, IN
Tel: 317-773-8323
Fax: 317-773-5453
Tel: 317-536-2380

Los Angeles

Mission Viejo, CA
Tel: 949-462-9523
Fax: 949-462-9608
Tel: 951-273-7800

Raleigh, NC

Tel: 919-844-7510

New York, NY

Tel: 631-435-6000

San Jose, CA

Tel: 408-735-9110
Tel: 408-436-4270

Canada - Toronto

Tel: 905-695-1980
Fax: 905-695-2078

ASIA/PACIFIC

Australia - Sydney
Tel: 61-2-9868-6733

China - Beijing
Tel: 86-10-8569-7000

China - Chengdu
Tel: 86-28-8665-5511

China - Chongqing
Tel: 86-23-8980-9588

China - Dongguan
Tel: 86-769-8702-9880

China - Guangzhou
Tel: 86-20-8755-8029

China - Hangzhou
Tel: 86-571-8792-8115

China - Hong Kong SAR
Tel: 852-2943-5100

China - Nanjing
Tel: 86-25-8473-2460

China - Qingdao
Tel: 86-532-8502-7355

China - Shanghai
Tel: 86-21-3326-8000

China - Shenyang
Tel: 86-24-2334-2829

China - Shenzhen
Tel: 86-755-8864-2200

China - Suzhou
Tel: 86-186-6233-1526

China - Wuhan
Tel: 86-27-5980-5300

China - Xian
Tel: 86-29-8833-7252

China - Xiamen
Tel: 86-592-2388138

China - Zhuhai
Tel: 86-756-3210040

ASIA/PACIFIC

India - Bangalore
Tel: 91-80-3090-4444

India - New Delhi
Tel: 91-11-4160-8631

India - Pune
Tel: 91-20-4121-0141

Japan - Osaka
Tel: 81-6-6152-7160

Japan - Tokyo
Tel: 81-3-6880-3770

Korea - Daegu
Tel: 82-53-744-4301

Korea - Seoul
Tel: 82-2-554-7200

Malaysia - Kuala Lumpur
Tel: 60-3-7651-7906

Malaysia - Penang
Tel: 60-4-227-8870

Philippines - Manila
Tel: 63-2-634-9065

Singapore
Tel: 65-6334-8870

Taiwan - Hsin Chu
Tel: 886-3-577-8366

Taiwan - Kaohsiung
Tel: 886-7-213-7830

Taiwan - Taipei
Tel: 886-2-2508-8600

Thailand - Bangkok
Tel: 66-2-694-1351

Vietnam - Ho Chi Minh
Tel: 84-28-5448-2100

EUROPE

Austria - Wels
Tel: 43-7242-2244-39
Fax: 43-7242-2244-393

Denmark - Copenhagen
Tel: 45-4485-5910
Fax: 45-4485-2829

Finland - Espoo
Tel: 358-9-4520-820

France - Paris
Tel: 33-1-69-53-63-20
Fax: 33-1-69-30-90-79

Germany - Garching
Tel: 49-8931-9700

Germany - Haan
Tel: 49-2129-3766400

Germany - Heilbronn
Tel: 49-7131-72400

Germany - Karlsruhe
Tel: 49-721-625370

Germany - Munich
Tel: 49-89-627-144-0
Fax: 49-89-627-144-44

Germany - Rosenheim
Tel: 49-8031-354-560

Israel - Ra'anana
Tel: 972-9-744-7705

Italy - Milan
Tel: 39-0331-742611
Fax: 39-0331-466781

Italy - Padova
Tel: 39-049-7625286

Netherlands - Drunen
Tel: 31-416-690399
Fax: 31-416-690340

Norway - Trondheim
Tel: 47-7288-4388

Poland - Warsaw
Tel: 48-22-3325737

Romania - Bucharest
Tel: 40-21-407-87-50

Spain - Madrid
Tel: 34-91-708-08-90
Fax: 34-91-708-08-91

Sweden - Gothenberg
Tel: 46-31-704-60-40

Sweden - Stockholm
Tel: 46-8-5090-4654

UK - Wokingham
Tel: 44-118-921-5800
Fax: 44-118-921-5820