

## LVPECL, LVDS Crystal Oscillator

### Features

- 40 fs<sub>RMS</sub> Phase Jitter Typical, 12 kHz to 20 MHz
- 3rd OT or Fundamental Crystal Design
- Extended Operating Temperature Range: -40°C to +105°C
- 80 MHz to 212.500 MHz Output Frequencies
- Excellent Power Supply Rejection Ratio
- Glitch Free Output upon Power-Up and Enable
- Hermetically Sealed 2.5 mm x 2.0 mm Ceramic Package
- Product is Compliant to RoHS Directive and Fully Compatible with Lead-Free Assembly

### Applications

- Optical Modules
- Medical, Ultrasound
- Ethernet, GbE, SynchronE
- Fibre Channel
- PON
- Clock Source for A/Ds, D/As, FPGAs
- Test and Measurement
- Storage Area Network

### General Description

Microchip's VC-844 crystal oscillator is a quartz-stabilized, differential output oscillator that operates off a 2.5V or 3.3V power supply in a hermetically sealed 2.5 mm x 2.0 mm ceramic package.

### Block Diagram

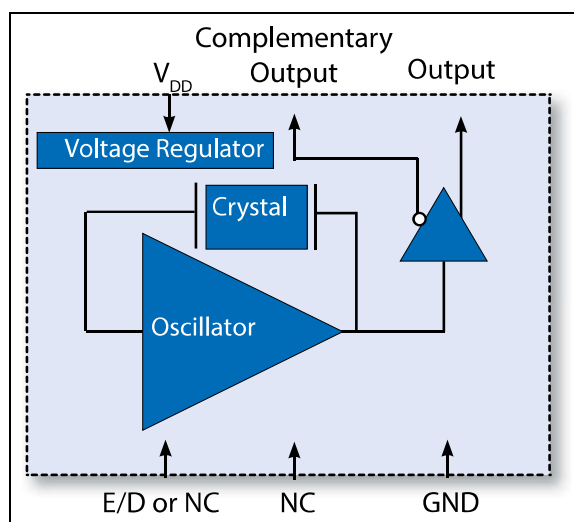

### Phase Noise Plot

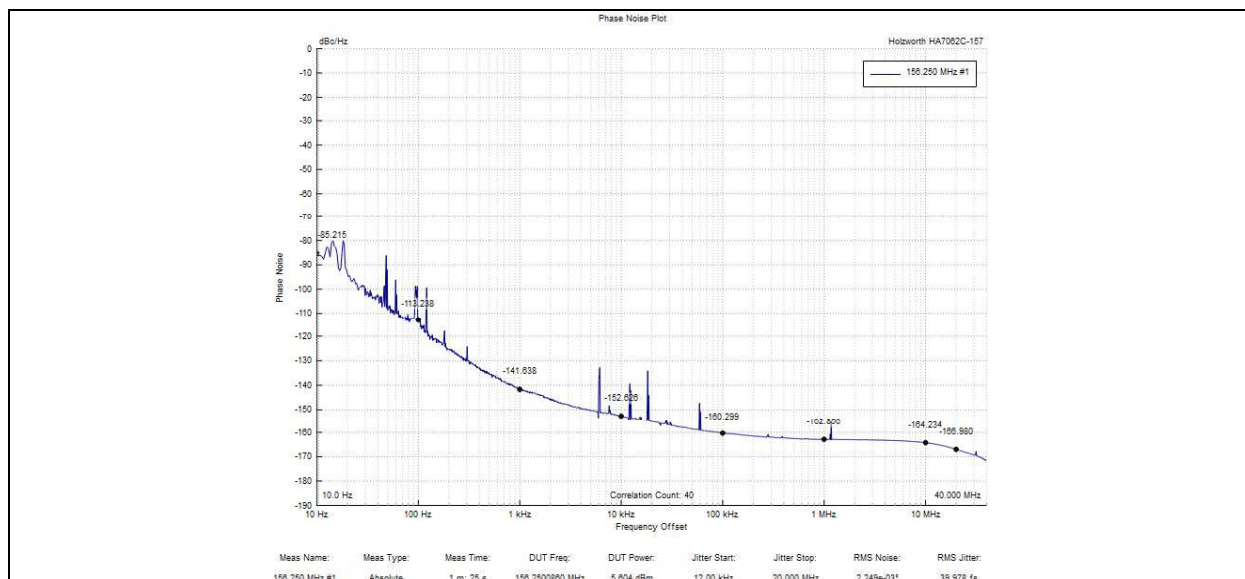

**FIGURE 0-1:** RMS Jitter, 40 fs<sub>RMS</sub> over 12 kHz to 20 MHz at 156.25 MHz.

# VC-844

## 1.0 ELECTRICAL CHARACTERISTICS

### Absolute Maximum Ratings †

Supply Voltage .....	-0.3V to +4.5V
Enable Disable Voltage .....	-0.3V to $V_{DD} + 0.3V$
ESD Rating, Human Body Model (Note 1) .....	2 kV
ESD Rating, Charged Device Model (Note 1) .....	200V
Storage Temperature ( $T_S$ ) .....	-55°C to +150°C
Junction Temperature ( $T_J$ ) .....	+150°C

† **Notice:** Stresses in excess of the Absolute Maximum Ratings can permanently damage the device. Functional operation is not implied at these or any other conditions in excess of conditions represented in the operational sections of this data sheet. Exposure to Absolute Maximum Ratings for extended periods may adversely affect device reliability.

**Note 1:** Although ESD protection circuitry has been designed into the VC-844, proper precautions should be taken when handling and mounting. Microchip employs a Human Body Model (HBM) and a Charged Device Model (CDM) for ESD susceptibility testing and design protection evaluation. ESD thresholds are dependent on the circuit parameters used to define the model. Although no industry standard has been adopted for the CDM, a standard resistance of 1.5 k $\Omega$  and capacitance of 100 pF is widely used and therefore can be used for comparison purposes.

### ELECTRICAL CHARACTERISTICS, LVPECL OPTION

Parameter	Sym.	Min.	Typ.	Max.	Units	Conditions
Supply Voltage (Note 1)	$V_{DD}$	2.375	2.5	2.625	V	Ordering Option
		3.135	3.3	3.465		
Current Consumption	$I_{DD}$	—	—	66	mA	—
<b>Frequency</b>						
Nominal Frequency	$f_N$	80	—	212.500	MHz	Ordering Option
Stability (Note 2)	—	—	—	$\pm 25$	ppm	Ordering Option
		—	—	$\pm 30$		
		—	—	$\pm 50$		
		—	—	$\pm 100$		
<b>Outputs</b>						
Output Logic Level High (Note 3)	$V_{OH}$	$V_{DD} - 1.085$	—	$V_{DD} - 0.860$	V	$V_{DD} = +2.5V$
Output Logic Level Low (Note 3)	$V_{OL}$	$V_{DD} - 1.810$	—	$V_{DD} - 1.620$		
Output Logic Level High (Note 3)	$V_{OH}$	$V_{DD} - 1.085$	—	$V_{DD} - 0.880$	V	$V_{DD} = +3.3V$
Output Logic Level Low (Note 3)	$V_{OL}$	$V_{DD} - 1.810$	—	$V_{DD} - 1.620$		

- Note 1:** The VC-844 power supply should be filtered. For example, a 10  $\mu F$ , 0.1  $\mu F$ , and 0.01  $\mu F$  capacitor.
- 2:** Includes calibration tolerance, operating temperature, supply voltage variations, aging, and IR reflow.
- 3:** Figure 1-1 defines the test circuit and Figure 1-2 defines these parameters.
- 4:** Output rise and fall time will be 600 ps (max.) for -40°C to +105°C operating temperature range.
- 5:** Duty Cycle is measured as On/Time Period.
- 6:** Measured using an Agilent E5052 Signal or Holzworth HA7062C at 25°C.
- 7:** Outputs will be enabled if Enable/Disable is left open. There is an oscillation detection circuit that ensures glitch free output upon power-up or enable.
- 8:** In order to reduce current, the pull-up resistance is higher when  $V_{DD}$  is set to ground.

## ELECTRICAL CHARACTERISTICS, LVPECL OPTION (CONTINUED)

Parameter	Sym.	Min.	Typ.	Max.	Units	Conditions
Output Rise and Fall Time (Note 3)	$t_r/t_f$	—	—	400	ps	Note 4
Load	—	50Ω into $V_{DD} - 2.0V$			—	—
Duty Cycle (Note 5)	DC	45	—	55	%	—
Phase Noise, 3.3V, 156.25 MHz (Note 6)	$\phi_N$	—	-79	—	dBc/Hz	10 Hz
		—	-110	—		100 Hz
		—	-141	—		1 kHz
		—	-152	—		10 kHz
		—	-160	—		100 kHz
		—	-163	—		1 MHz
		—	-164	—		20 MHz
Phase Jitter, 156.25 MHz, 12 kHz to 20 MHz (Note 6)	$\phi_J$	—	40	60	fs	—
<b>Enable/Disable</b>						
Outputs Enabled (Note 7)	$V_{IH}$	$0.7 * V_{DD}$	—	—	V	—
Outputs Disabled	$V_{IL}$	—	—	$0.3 * V_{DD}$	V	—
Disable Time	$t_D$	—	—	200	ns	—
E/D Pull-Up Resistance (Note 8)	—	0.5	—	2	MΩ	E/D = GND
E/D Pull-Up Resistance	—	30	—	150	kΩ	E/D = $V_{DD}$
Start-Up Time	$t_{SU}$	—	—	5	ms	—
Operating Temperature	$T_{OP}$	-10	—	70	°C	Ordering Option
		-40	—	85		
		-40	—	105		

- Note 1:** The VC-844 power supply should be filtered. For example, a 10 μF, 0.1 μF, and 0.01 μF capacitor.
- Note 2:** Includes calibration tolerance, operating temperature, supply voltage variations, aging, and IR reflow.
- Note 3:** Figure 1-1 defines the test circuit and Figure 1-2 defines these parameters.
- Note 4:** Output rise and fall time will be 600 ps (max.) for -40°C to +105°C operating temperature range.
- Note 5:** Duty Cycle is measured as On/Time Period.
- Note 6:** Measured using an Agilent E5052 Signal or Holzworth HA7062C at 25°C.
- Note 7:** Outputs will be enabled if Enable/Disable is left open. There is an oscillation detection circuit that ensures glitch free output upon power-up or enable.
- Note 8:** In order to reduce current, the pull-up resistance is higher when  $V_{DD}$  is set to ground.

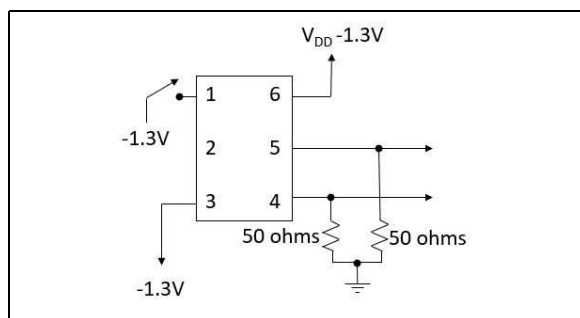

**FIGURE 1-1:** Test Circuit.

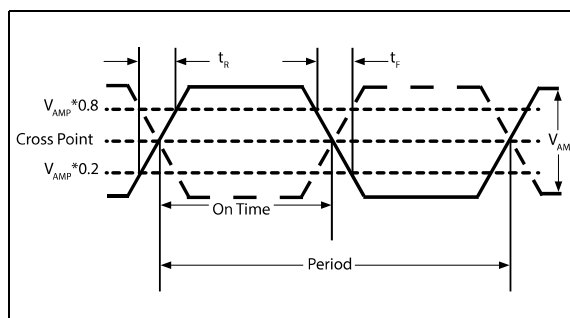

**FIGURE 1-2:** Output Rise/Fall Time.

## ELECTRICAL CHARACTERISTICS, LVDS OPTION

Parameter	Sym.	Min.	Typ.	Max.	Units	Conditions
Supply Voltage (Note 1)	$V_{DD}$	2.375	2.5	2.625	V	Ordering Option
		3.135	3.3	3.465		
Current Consumption	$I_{DD}$			30	mA	—
<b>Frequency</b>						
Nominal Frequency	$f_N$	80	—	212.500	MHz	Ordering Option
Stability (Note 2)	—	—	—	±25	ppm	Ordering Option
		—	—	±30		
		—	—	±50		
		—	—	±100		
<b>Outputs</b>						
Output Logic Level High (Note 3)	$V_{OH}$	—	1.43	1.6	V	—
Output Logic Level Low (Note 3)	$V_{OL}$	0.9	1.10	—		
Output Amplitude	—	±247	±350	±454	mV	—
Differential Output Error	—	—	—	50	mV	—
Offset Voltage	—	1.125	1.25	1.375	V	—
Offset Voltage Error	—	—	—	50	mV	—
Output Leakage Current, Outputs Disabled	—	—	—	30	μA	—
Output Rise and Fall Time (Note 3)	$t_r/t_f$	—	—	300	ps	Note 4
Load	—	100Ω Differential			—	—
Duty Cycle (Note 5)	DC	45	—	55	%	—
Phase Noise, 3.3V, 156.25 MHz (Note 6)	$\phi_N$	—	-79	—	dBc/Hz	10 Hz
		—	-110	—		100 Hz
		—	-141	—		1 kHz
		—	-152	—		10 kHz
		—	-160	—		100 kHz
		—	-163	—		1 MHz
		—	-164	—		20 MHz
		—	-170	—		40 MHz
Phase Jitter, 156.25 MHz, 12 kHz to 20 MHz (Note 6)	$\phi_J$	—	40	60	fs	—

- Note 1:** The VC-844 power supply should be filtered. For example, a 10 μF, 0.1 μF, and 0.01 μF capacitor.
- Note 2:** Includes calibration tolerance, operating temperature, supply voltage variations, aging, and IR reflow.
- Note 3:** Figure 1-3 defines the test circuit and Figure 1-2 defines these parameters.
- Note 4:** Output rise and fall time will be 600 ps (max.) for -40°C to +105°C operating temperature range.
- Note 5:** Duty Cycle is measured as On/Time Period.
- Note 6:** Measured using an Agilent E5052 or Holzworth HA7062C at 25°C.
- Note 7:** Outputs will be enabled if Enable/Disable is left open. There is an oscillation detection circuit that ensures glitch free output upon power-up or enable.
- Note 8:** In order to reduce current, the pull-up resistance is higher when  $V_{DD}$  is set to ground.

## ELECTRICAL CHARACTERISTICS, LVDS OPTION (CONTINUED)

Parameter	Sym.	Min.	Typ.	Max.	Units	Conditions
<b>Enable/Disable</b>						
Outputs Enabled (Note 7)	$V_{IH}$	$0.7 * V_{DD}$	—	—	V	—
Outputs Disabled	$V_{IL}$	—	—	$0.3 * V_{DD}$	V	—
Disable Time	$t_D$	—	—	200	ns	—
E/D Pull-Up Resistance (Note 8)	—	0.5	—	2	M $\Omega$	E/D = GND
E/D Pull-Up Resistance	—	30	—	150	k $\Omega$	E/D = $V_{DD}$
Start-Up Time	$t_{SU}$	—	—	5	ms	—
Operating Temperature	$T_{OP}$	-10	—	70	°C	Ordering Option
		-40	—	85		
		-40	—	105		

- Note 1:** The VC-844 power supply should be filtered. For example, a 10  $\mu$ F, 0.1  $\mu$ F, and 0.01  $\mu$ F capacitor.
- Note 2:** Includes calibration tolerance, operating temperature, supply voltage variations, aging, and IR reflow.
- Note 3:** Figure 1-3 defines the test circuit and Figure 1-2 defines these parameters.
- Note 4:** Output rise and fall time will be 600 ps (max.) for  $-40^{\circ}\text{C}$  to  $+105^{\circ}\text{C}$  operating temperature range.
- Note 5:** Duty Cycle is measured as On/Time Period.
- Note 6:** Measured using an Agilent E5052 or Holzworth HA7062C at  $25^{\circ}\text{C}$ .
- Note 7:** Outputs will be enabled if Enable/Disable is left open. There is an oscillation detection circuit that ensures glitch free output upon power-up or enable.
- Note 8:** In order to reduce current, the pull-up resistance is higher when  $V_{DD}$  is set to ground.

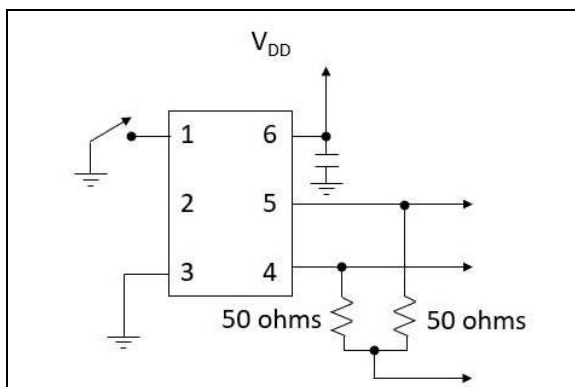

**FIGURE 1-3:** LVDS Test Circuit.

# VC-844

---

## 2.0 PIN DESCRIPTIONS

The descriptions of the pins are listed in [Table 2-1](#).

**TABLE 2-1: PIN FUNCTION TABLE**

Pin Number	Pin Name	Description
1	E/D	Enable/Disable.
2	NC	No connection.
3	GND	Electrical and lid ground.
4	$f_O$	Output frequency.
5	$Cf_O$	Complementary output frequency.
6	$V_{DD}$	Supply voltage.

**TABLE 2-2: ENABLE/DISABLE FUNCTION**

E/D Pin	Output
High	Clock Output
Open	Clock Output
Low	High Impedance

## 3.0 APPLICATION DIAGRAMS

### 3.1 LVPECL Application Diagrams

The VC-844 incorporates a standard PECL output scheme, which are unterminated FET drains. There are numerous application notes on terminating and interfacing PECL logic and the two most common methods are a single resistor to ground (Figure 3-1) and, for best 50Ω matching, a pull-up/pull-down scheme as shown in Figure 3-2. AC-blocking capacitors are optional, depending on the application and the input logic requirements of the next stage.

One of the most important considerations is terminating the Output and Complementary Outputs equally. An unused output should not be left unterminated because if one of the two outputs is left open, it will result in excessive jitter on both. PCB layout must take this and 50Ω impedance matching into account. Load matching and power supply noise are the main contributors to jitter related problems.

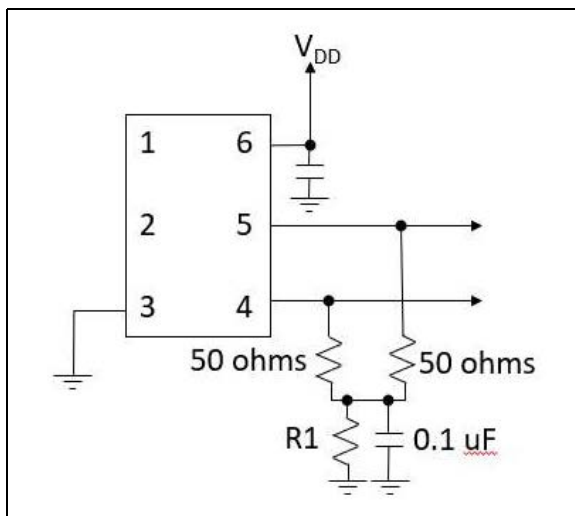

**FIGURE 3-1:** Pull-Down Resistor Termination Scheme.

Figure 3-1 shows one option to terminate LVPECL outputs and is optimized to reduce common mode noise. R1 is 50Ω for 3.3V supply voltage and 18Ω for 2.5V.

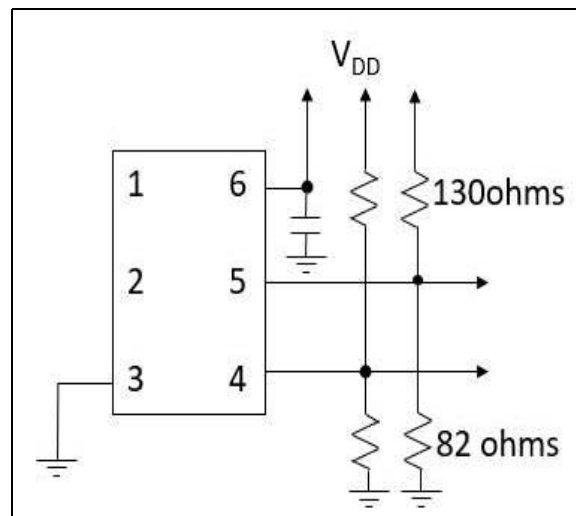
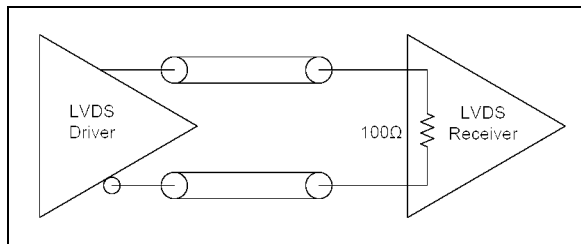

**FIGURE 3-2:** Pull-Up/Pull-Down Termination.

Resistor values shown are typical for 3.3V operation. For 2.5V operation, the resistor to ground is 62Ω and the resistor to supply is 250Ω.

## 3.2 LVDS Application Diagrams

One of the most important considerations is terminating the Output and Complementary Outputs equally. An unused output should not be left unterminated because if one of the two outputs is left open, it will result in excessive jitter on both. PCB layout must take this and 50Ω impedance matching into account. Load matching and power supply noise are the main contributors to jitter related problems.



**FIGURE 3-3:** LVDS-to-LVDS Connection, Internal 100Ω Resistor.

Some LVDS structures have an internal 100Ω resistor on the input and do not need additional components. AC-blocking capacitors can be used if the DC levels are incompatible.

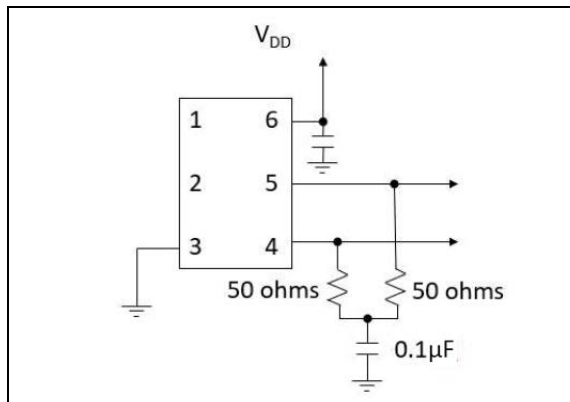

**FIGURE 3-4:** LVDS-to-LVDS Connection.

Some input structures may not have an internal 100Ω resistor on the input and will need an external 100Ω resistor located at the receiver for impedance matching. Figure 3-4 is optimized to reduce common mode noise. Additionally, the input may have an internal DC bias that may not be compatible with LVDS levels. AC-blocking capacitors, such as 0.1 μF, should be used in this case.

## 4.0 RELIABILITY

Microchip qualification will include aging at various extreme temperatures, shock and vibration, temperature cycling, and IR reflow simulation. The VC-844 family is capable of meeting the following qualification tests.

**TABLE 4-1: ENVIRONMENTAL COMPLIANCE**

Parameter	Conditions
Mechanical Shock	MIL-STD-883, Method 2002
Mechanical Vibration	MIL-STD-883, Method 2007
Temperature Cycle	MIL-STD-883, Method 1010
Solderability	MIL-STD-883, Method 2003
Gross and Fine Leak	MIL-STD-883, Method 1014
Resistance to Solvents	MIL-STD-883, Method 2015
Moisture Sensitivity Level	MSL 1
Contact Pads	Gold (0.3 $\mu\text{m}$ min., 1.0 $\mu\text{m}$ max.) over Nickel
$\theta_{\text{JC}}$ (Bottom of Case)	27°C/W
Maximum Junction Temperature	150°C
Weight	15 mg

## 5.0 IR REFLOW

Devices are built using lead-free epoxy and can be subjected to standard lead-free IR reflow conditions shown in [Table 5-1](#). Contact pads are gold over nickel and lower maximum temperatures can also be used, such as 220°C.

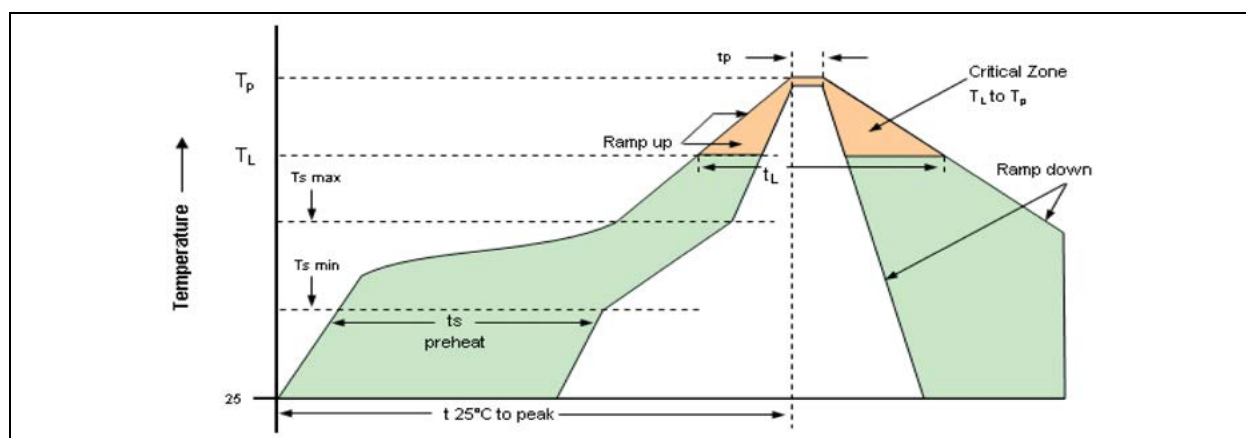

**FIGURE 5-1:** Solder Profile.

**TABLE 5-1: REFLOW PROFILE**

Parameter	Symbol	Value
Pre-Heat Time	$t_{\text{S}}$	200 seconds maximum
Ramp Up	$R_{\text{UP}}$	3°C/sec. maximum
Time above 217°C	$t_{\text{L}}$	150 seconds maximum
Time to Peak Temperature	$T_{\text{AMB-P}}$	480 seconds maximum
Time at 260°C	$t_{\text{P}}$	30 seconds maximum
Time at 240°C	$t_{\text{P2}}$	60 seconds maximum
Ramp Down	$R_{\text{DN}}$	6°C/sec. maximum

# VC-844

## 6.0 TAPE AND REEL

TABLE 6-1: TAPE AND REEL DIMENSIONS

Tape Dimensions (mm)						Reel Dimensions (mm)							
Dimension	W	F	Do	Po	P1	A	B	C	D	N	W1	W2	# per Reel
Tolerance	Typ	Typ	Typ	Typ	Typ	Typ	Typ	Typ	Typ	Typ	Typ	Max	
VC-844	8	3.5	1.5	4	4	178	2	13	21	60	10	14	3000

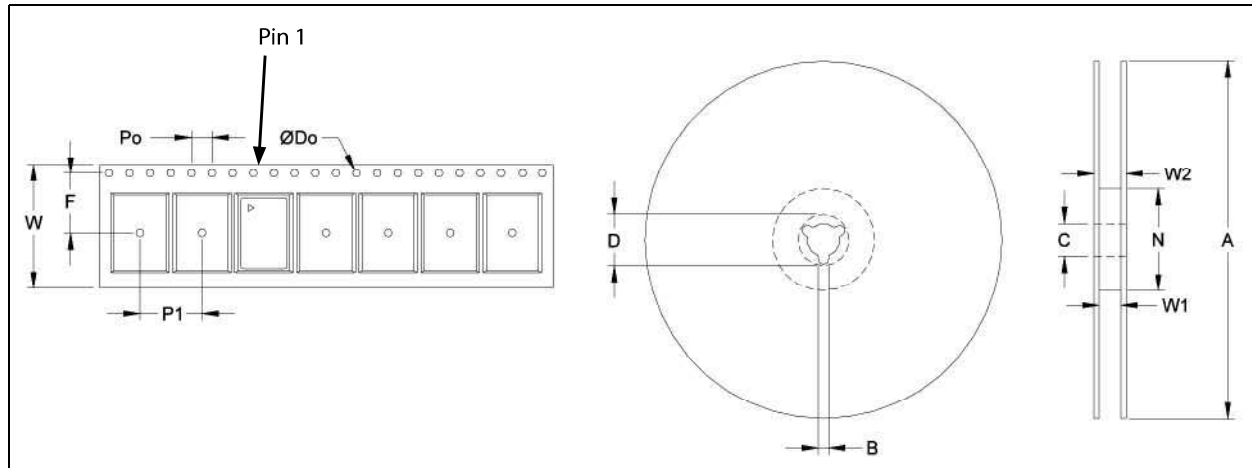

## 7.0 PACKAGING INFORMATION

### 6-Lead 2.5 mm x 2.0 mm VDFN Package Outline and Recommended Land Pattern

**Note:** For the most current package drawings, please see the Microchip Packaging Specification located at <http://www.microchip.com/packaging>

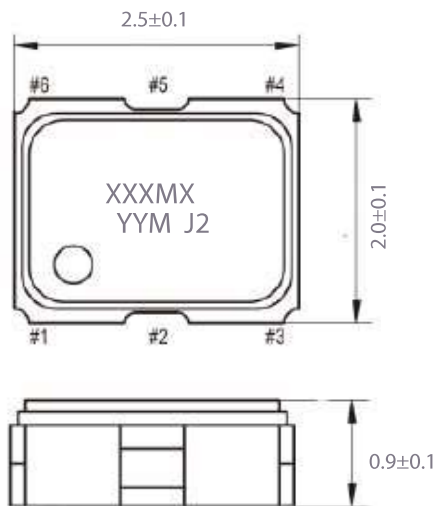

Dimensions in mm

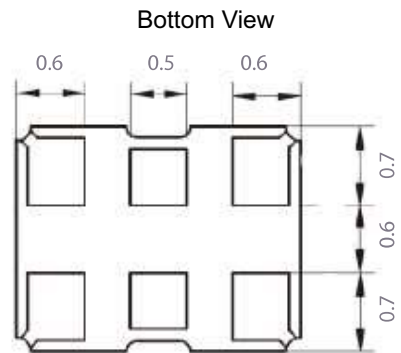

**Marking Information:**

XXXMX = Frequency (example: 100M0)  
 YY = Year of Manufacture  
 M = Month of the Year  
 J2 = Manufacturing Location  
 ● = Pin 1 Indicator

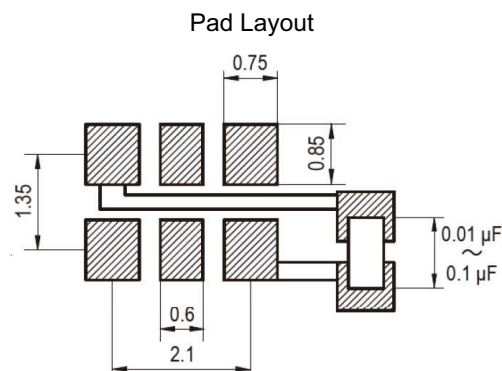

# VC-844

---

NOTES:

## APPENDIX A: REVISION HISTORY

### Revision A (September 2021)

- Converted Vectron document VC-844 to Microchip data sheet template DS20006581A.
- Minor grammatical text changes throughout.

# VC-844

---

NOTES:

## PRODUCT IDENTIFICATION SYSTEM

To order or obtain information, e.g., on pricing or delivery, contact your local Microchip representative or sales office.

<u>Device</u>	<u>-X</u>	<u>X</u>	<u>X</u>	<u>-X</u>	<u>X</u>	<u>X</u>	<u>X</u>	<u>-XXXXXXXXXX</u>	<u>XX</u>
Part No.	Power Supply	Output	Temp. Range	Stability	Other	E/D Pin	Other	Frequency	Packaging
<b>Device:</b>	VC-844:	LVPECL, LVDS Crystal Oscillator in 6-Lead 2.5 mm x 2.0 mm VDFN							
<b>Power Supply:</b>	E =	3.3VDC ±5%							
	H =	2.5VDC ±5%							
<b>Output:</b>	C =	LVPECL							
	D =	LVDS							
<b>Temperature Range:</b>	E =	-40°C to +85°C							
	F =	-40°C to +105°C							
	W =	-10°C to +70°C							
<b>Stability:</b>	F =	±25 ppm							
	G =	±30 ppm							
	K =	±50 ppm							
	S =	±100 ppm							
<b>Other (Future Use):</b>	A =	Standard							
<b>Enable/Disable Pin:</b>	A =	Pin 1 (Pin 2 = No Connect)							
<b>Other (Future Use):</b>	N =	Standard							
<b>Frequency:</b>	xxxMxxxxx=Frequency in MHz								
<b>Packaging:</b>	TR =	3,000/Reel							
	<blank>=	Cut Tape/ non-TR quantities							
<b>Examples:</b>									
a) VC-844-ECF-GAAN-156M250000TR: VC-844, 3.3VDC, LVPECL Output, -40°C to +105°C Temp Range, ±30 ppm Stability, Pin 1 Enable/Disable, 156.25 MHz, 3000/Reel									
b) VC-844-HDW-KAAN-125M000000TR: VC-844, 2.5VDC, LVDS Output, -10°C to +70°C Temp Range, ±50 ppm Stability, Pin 1 Enable/Disable, 125 MHz, 3000/Reel									
<b>Note 1:</b> Tape and Reel identifier only appears in the catalog part number description. This identifier is used for ordering purposes and is not printed on the device package. Check with your Microchip Sales Office for package availability with the Tape and Reel option.									

**Note:** Not all combinations of options are available. Other specifications may be available upon request.

## STANDARD FREQUENCIES (MHz)

80.000	83.000	90.000	98.304	100.000	106.250	120.000
125.000	127.000	133.000	148.500	150.000	153.600	155.520
156.250	160.000	166.000	167.3316	180.000	200.000	212.500

# VC-844

---

---

NOTES:

---

---

**Note the following details of the code protection feature on Microchip devices:**

- Microchip products meet the specifications contained in their particular Microchip Data Sheet.
- Microchip believes that its family of products is secure when used in the intended manner and under normal conditions.
- There are dishonest and possibly illegal methods being used in attempts to breach the code protection features of the Microchip devices. We believe that these methods require using the Microchip products in a manner outside the operating specifications contained in Microchip's Data Sheets. Attempts to breach these code protection features, most likely, cannot be accomplished without violating Microchip's intellectual property rights.
- Microchip is willing to work with any customer who is concerned about the integrity of its code.
- Neither Microchip nor any other semiconductor manufacturer can guarantee the security of its code. Code protection does not mean that we are guaranteeing the product is "unbreakable." Code protection is constantly evolving. We at Microchip are committed to continuously improving the code protection features of our products. Attempts to break Microchip's code protection feature may be a violation of the Digital Millennium Copyright Act. If such acts allow unauthorized access to your software or other copyrighted work, you may have a right to sue for relief under that Act.

---

Information contained in this publication is provided for the sole purpose of designing with and using Microchip products. Information regarding device applications and the like is provided only for your convenience and may be superseded by updates. It is your responsibility to ensure that your application meets with your specifications.

THIS INFORMATION IS PROVIDED BY MICROCHIP "AS IS". MICROCHIP MAKES NO REPRESENTATIONS OR WARRANTIES OF ANY KIND WHETHER EXPRESS OR IMPLIED, WRITTEN OR ORAL, STATUTORY OR OTHERWISE, RELATED TO THE INFORMATION INCLUDING BUT NOT LIMITED TO ANY IMPLIED WARRANTIES OF NON-INFRINGEMENT, MERCHANTABILITY, AND FITNESS FOR A PARTICULAR PURPOSE OR WARRANTIES RELATED TO ITS CONDITION, QUALITY, OR PERFORMANCE.

IN NO EVENT WILL MICROCHIP BE LIABLE FOR ANY INDIRECT, SPECIAL, PUNITIVE, INCIDENTAL OR CONSEQUENTIAL LOSS, DAMAGE, COST OR EXPENSE OF ANY KIND WHATSOEVER RELATED TO THE INFORMATION OR ITS USE, HOWEVER CAUSED, EVEN IF MICROCHIP HAS BEEN ADVISED OF THE POSSIBILITY OR THE DAMAGES ARE FORESEEABLE. TO THE FULLEST EXTENT ALLOWED BY LAW, MICROCHIP'S TOTAL LIABILITY ON ALL CLAIMS IN ANY WAY RELATED TO THE INFORMATION OR ITS USE WILL NOT EXCEED THE AMOUNT OF FEES, IF ANY, THAT YOU HAVE PAID DIRECTLY TO MICROCHIP FOR THE INFORMATION. Use of Microchip devices in life support and/or safety applications is entirely at the buyer's risk, and the buyer agrees to defend, indemnify and hold harmless Microchip from any and all damages, claims, suits, or expenses resulting from such use. No licenses are conveyed, implicitly or otherwise, under any Microchip intellectual property rights unless otherwise stated.

### Trademarks

The Microchip name and logo, the Microchip logo, Adaptec, AnyRate, AVR, AVR logo, AVR Freaks, BesTime, BitCloud, chipKIT, chipKIT logo, CryptoMemory, CryptoRF, dsPIC, FlashFlex, flexPWR, HELDO, IGL00, JukeBlox, KeeLoq, Klear, LANCheck, LinkMD, maXStylus, maXTouch, MediaLB, megaAVR, Microsemi, Microsemi logo, MOST, MOST logo, MPLAB, OptoLyzr, PackeTime, PIC, picoPower, PICSTART, PIC32 logo, PolarFire, Prochip Designer, QTouch, SAM-BA, SenGenuity, SpyNIC, SST, SST Logo, SuperFlash, Symmetricom, SyncServer, Tachyon, TimeSource, tinyAVR, UNI/O, Vectron, and XMEGA are registered trademarks of Microchip Technology Incorporated in the U.S.A. and other countries.

AgileSwitch, APT, ClockWorks, The Embedded Control Solutions Company, EtherSynch, FlashTec, Hyper Speed Control, HyperLight Load, IntelliMOS, Libero, motorBench, mTouch, Powermite 3, Precision Edge, ProASIC, ProASIC Plus, ProASIC Plus logo, Quiet-Wire, SmartFusion, SyncWorld, Temux, TimeCesium, TimeHub, TimePictra, TimeProvider, WinPath, and ZL are registered trademarks of Microchip Technology Incorporated in the U.S.A.

Adjacent Key Suppression, AKS, Analog-for-the-Digital Age, Any Capacitor, AnyIn, AnyOut, Augmented Switching, BlueSky, BodyCom, CodeGuard, CryptoAuthentication, CryptoAutomotive, CryptoCompanion, CryptoController, dsPICDEM, dsPICDEM.net, Dynamic Average Matching, DAM, ECAN, Espresso T1S, EtherGREEN, IdealBridge, In-Circuit Serial Programming, ICSP, INICnet, Intelligent Paralleling, Inter-Chip Connectivity, JitterBlocker, maxCrypto, maxView, memBrain, Mindi, MiWi, MPASM, MPF, MPLAB Certified logo, MPLIB, MPLINK, MultiTRAK, NetDetach, Omniscient Code Generation, PICDEM, PICDEM.net, PICkit, PICtail, PowerSmart, PureSilicon, QMatrix, REAL ICE, Ripple Blocker, RTAX, RTG4, SAM-ICE, Serial Quad I/O, simpleMAP, SimpliPHY, SmartBuffer, SMART-I.S., storClad, SQI, SuperSwitcher, SuperSwitcher II, Switchtec, SynchroPHY, Total Endurance, TSHARC, USBCheck, VariSense, VectorBlox, VeriPHY, ViewSpan, WiperLock, XpressConnect, and ZENA are trademarks of Microchip Technology Incorporated in the U.S.A. and other countries.

SQTP is a service mark of Microchip Technology Incorporated in the U.S.A.

The Adaptec logo, Frequency on Demand, Silicon Storage Technology, and Symmcom are registered trademarks of Microchip Technology Inc. in other countries.

GestIC is a registered trademark of Microchip Technology Germany II GmbH & Co. KG, a subsidiary of Microchip Technology Inc., in other countries.

All other trademarks mentioned herein are property of their respective companies.

© 2021, Microchip Technology Incorporated, All Rights Reserved.

ISBN: 978-1-5224-8872-9

For information regarding Microchip's Quality Management Systems, please visit [www.microchip.com/quality](http://www.microchip.com/quality).



# MICROCHIP

## Worldwide Sales and Service

### AMERICAS

#### Corporate Office

2355 West Chandler Blvd.  
Chandler, AZ 85224-6199

Tel: 480-792-7200

Fax: 480-792-7277

Technical Support:

[http://www.microchip.com/  
support](http://www.microchip.com/support)

Web Address:

[www.microchip.com](http://www.microchip.com)

#### Atlanta

Duluth, GA

Tel: 678-957-9614

Fax: 678-957-1455

#### Austin, TX

Tel: 512-257-3370

#### Boston

Westborough, MA

Tel: 774-760-0087

Fax: 774-760-0088

#### Chicago

Itasca, IL

Tel: 630-285-0071

Fax: 630-285-0075

#### Dallas

Addison, TX

Tel: 972-818-7423

Fax: 972-818-2924

#### Detroit

Novi, MI

Tel: 248-848-4000

#### Houston, TX

Tel: 281-894-5983

#### Indianapolis

Noblesville, IN

Tel: 317-773-8323

Fax: 317-773-5453

Tel: 317-536-2380

#### Los Angeles

Mission Viejo, CA

Tel: 949-462-9523

Fax: 949-462-9608

Tel: 951-273-7800

#### Raleigh, NC

Tel: 919-844-7510

#### New York, NY

Tel: 631-435-6000

#### San Jose, CA

Tel: 408-735-9110

Tel: 408-436-4270

#### Canada - Toronto

Tel: 905-695-1980

Fax: 905-695-2078

### ASIA/PACIFIC

#### Australia - Sydney

Tel: 61-2-9868-6733

#### China - Beijing

Tel: 86-10-8569-7000

#### China - Chengdu

Tel: 86-28-8665-5511

#### China - Chongqing

Tel: 86-23-8980-9588

#### China - Dongguan

Tel: 86-769-8702-9880

#### China - Guangzhou

Tel: 86-20-8755-8029

#### China - Hangzhou

Tel: 86-571-8792-8115

#### China - Hong Kong SAR

Tel: 852-2943-5100

#### China - Nanjing

Tel: 86-25-8473-2460

#### China - Qingdao

Tel: 86-532-8502-7355

#### China - Shanghai

Tel: 86-21-3326-8000

#### China - Shenyang

Tel: 86-24-2334-2829

#### China - Shenzhen

Tel: 86-755-8864-2200

#### China - Suzhou

Tel: 86-186-6233-1526

#### China - Wuhan

Tel: 86-27-5980-5300

#### China - Xian

Tel: 86-29-8833-7252

#### China - Xiamen

Tel: 86-592-2388138

#### China - Zhuhai

Tel: 86-756-3210040

### ASIA/PACIFIC

#### India - Bangalore

Tel: 91-80-3090-4444

#### India - New Delhi

Tel: 91-11-4160-8631

#### India - Pune

Tel: 91-20-4121-0141

#### Japan - Osaka

Tel: 81-6-6152-7160

#### Japan - Tokyo

Tel: 81-3-6880-3770

#### Korea - Daegu

Tel: 82-53-744-4301

#### Korea - Seoul

Tel: 82-2-554-7200

#### Malaysia - Kuala Lumpur

Tel: 60-3-7651-7906

#### Malaysia - Penang

Tel: 60-4-227-8870

#### Philippines - Manila

Tel: 63-2-634-9065

#### Singapore

Tel: 65-6334-8870

#### Taiwan - Hsin Chu

Tel: 886-3-577-8366

#### Taiwan - Kaohsiung

Tel: 886-7-213-7830

#### Taiwan - Taipei

Tel: 886-2-2508-8600

#### Thailand - Bangkok

Tel: 66-2-694-1351

#### Vietnam - Ho Chi Minh

Tel: 84-28-5448-2100

### EUROPE

#### Austria - Wels

Tel: 43-7242-2244-39

Fax: 43-7242-2244-393

#### Denmark - Copenhagen

Tel: 45-4485-5910

Fax: 45-4485-2829

#### Finland - Espoo

Tel: 358-9-4520-820

#### France - Paris

Tel: 33-1-69-53-63-20

Fax: 33-1-69-30-90-79

#### Germany - Garching

Tel: 49-8931-9700

#### Germany - Haan

Tel: 49-2129-3766400

#### Germany - Heilbronn

Tel: 49-7131-72400

#### Germany - Karlsruhe

Tel: 49-721-625370

#### Germany - Munich

Tel: 49-89-627-144-0

Fax: 49-89-627-144-44

#### Germany - Rosenheim

Tel: 49-8031-354-560

#### Israel - Ra'anana

Tel: 972-9-744-7705

#### Italy - Milan

Tel: 39-0331-742611

Fax: 39-0331-466781

#### Italy - Padova

Tel: 39-049-7625286

#### Netherlands - Drunen

Tel: 31-416-690399

Fax: 31-416-690340

#### Norway - Trondheim

Tel: 47-7288-4388

#### Poland - Warsaw

Tel: 48-22-3325737

#### Romania - Bucharest

Tel: 40-21-407-87-50

#### Spain - Madrid

Tel: 34-91-708-08-90

Fax: 34-91-708-08-91

#### Sweden - Gothenberg

Tel: 46-31-704-60-40

#### Sweden - Stockholm

Tel: 46-8-5090-4654

#### UK - Wokingham

Tel: 44-118-921-5800

Fax: 44-118-921-5820