



MICROCHIP

MCP16502
Evaluation Board
User's Guide

Note the following details of the code protection feature on Microchip products:

- Microchip products meet the specifications contained in their particular Microchip Data Sheet.
- Microchip believes that its family of products is secure when used in the intended manner, within operating specifications, and under normal conditions.
- Microchip values and aggressively protects its intellectual property rights. Attempts to breach the code protection features of Microchip product is strictly prohibited and may violate the Digital Millennium Copyright Act.
- Neither Microchip nor any other semiconductor manufacturer can guarantee the security of its code. Code protection does not mean that we are guaranteeing the product is "unbreakable" Code protection is constantly evolving. Microchip is committed to continuously improving the code protection features of our products.

This publication and the information herein may be used only with Microchip products, including to design, test, and integrate Microchip products with your application. Use of this information in any other manner violates these terms. Information regarding device applications is provided only for your convenience and may be superseded by updates. It is your responsibility to ensure that your application meets with your specifications. Contact your local Microchip sales office for additional support or, obtain additional support at <https://www.microchip.com/en-us/support/design-help/client-support-services>.

THIS INFORMATION IS PROVIDED BY MICROCHIP "AS IS". MICROCHIP MAKES NO REPRESENTATIONS OR WARRANTIES OF ANY KIND WHETHER EXPRESS OR IMPLIED, WRITTEN OR ORAL, STATUTORY OR OTHERWISE, RELATED TO THE INFORMATION INCLUDING BUT NOT LIMITED TO ANY IMPLIED WARRANTIES OF NON-INFRINGEMENT, MERCHANTABILITY, AND FITNESS FOR A PARTICULAR PURPOSE, OR WARRANTIES RELATED TO ITS CONDITION, QUALITY, OR PERFORMANCE.

IN NO EVENT WILL MICROCHIP BE LIABLE FOR ANY INDIRECT, SPECIAL, PUNITIVE, INCIDENTAL, OR CONSEQUENTIAL LOSS, DAMAGE, COST, OR EXPENSE OF ANY KIND WHATSOEVER RELATED TO THE INFORMATION OR ITS USE, HOWEVER CAUSED, EVEN IF MICROCHIP HAS BEEN ADVISED OF THE POSSIBILITY OR THE DAMAGES ARE FORESEEABLE. TO THE FULLEST EXTENT ALLOWED BY LAW, MICROCHIP'S TOTAL LIABILITY ON ALL CLAIMS IN ANY WAY RELATED TO THE INFORMATION OR ITS USE WILL NOT EXCEED THE AMOUNT OF FEES, IF ANY, THAT YOU HAVE PAID DIRECTLY TO MICROCHIP FOR THE INFORMATION.

Use of Microchip devices in life support and/or safety applications is entirely at the buyer's risk, and the buyer agrees to defend, indemnify and hold harmless Microchip from any and all damages, claims, suits, or expenses resulting from such use. No licenses are conveyed, implicitly or otherwise, under any Microchip intellectual property rights unless otherwise stated.

For information regarding Microchip's Quality Management Systems, please visit www.microchip.com/quality.

Trademarks

The Microchip name and logo, the Microchip logo, Adaptec, AVR, AVR logo, AVR Freaks, BesTime, BitCloud, CryptoMemory, CryptoRF, dsPIC, flexPWR, HELDO, IGL00, JukeBlox, KeeLoq, Klear, LANCheck, LinkMD, maXStylus, maXTouch, MediaLB, megaAVR, Microsemi, Microsemi logo, MOST, MOST logo, MPLAB, OptoLyzer, PIC, picoPower, PICSTART, PIC32 logo, PolarFire, Prochip Designer, QTouch, SAM-BA, SenGenuity, SpyNIC, SST, SST Logo, SuperFlash, Symmetricom, SyncServer, Tachyon, TimeSource, tinyAVR, UNI/O, Vectron, and XMEGA are registered trademarks of Microchip Technology Incorporated in the U.S.A. and other countries.

AgileSwitch, APT, ClockWorks, The Embedded Control Solutions Company, EtherSynch, Flashtec, Hyper Speed Control, HyperLight Load, Libero, motorBench, mTouch, Powermite 3, Precision Edge, ProASIC, ProASIC Plus, ProASIC Plus logo, Quiet-Wire, SmartFusion, SyncWorld, Temux, TimeCesium, TimeHub, TimePictra, TimeProvider, TrueTime, and ZL are registered trademarks of Microchip Technology Incorporated in the U.S.A.

Adjacent Key Suppression, AKS, Analog-for-the-Digital Age, Any Capacitor, AnyIn, AnyOut, Augmented Switching, BlueSky, BodyCom, Clockstudio, CodeGuard, CryptoAuthentication, CryptoAutomotive, CryptoCompanion, CryptoController, dsPICDEM, dsPICDEM.net, Dynamic Average Matching, DAM, ECAN, Espresso T1S, EtherGREEN, GridTime, IdealBridge, In-Circuit Serial Programming, ICSP, INICnet, Intelligent Paralleling, IntelliMOS, Inter-Chip Connectivity, JitterBlocker, Knob-on-Display, KoD, maxCrypto, maxView, memBrain, Mindi, MiWi, MPASM, MPF, MPLAB Certified logo, MPLIB, MPLINK, MultiTRAK, NetDetach, Omniscient Code Generation, PICDEM, PICDEM.net, PICkit, PICtail, PowerSmart, PureSilicon, QMatrix, REAL ICE, Ripple Blocker, RTAX, RTG4, SAM-ICE, Serial Quad I/O, simpleMAP, SimpliPHY, SmartBuffer, SmartHLS, SMART-I.S., storClad, SQI, SuperSwitcher, SuperSwitcher II, Switchtec, SynchroPHY, Total Endurance, Trusted Time, TSHARC, USBCheck, VariSense, VectorBlox, VeriPHY, ViewSpan, WiperLock, XpressConnect, and ZENA are trademarks of Microchip Technology Incorporated in the U.S.A. and other countries.

SQTP is a service mark of Microchip Technology Incorporated in the U.S.A.

The Adaptec logo, Frequency on Demand, Silicon Storage Technology, and Symmcom are registered trademarks of Microchip Technology Inc. in other countries.

GestIC is a registered trademark of Microchip Technology Germany II GmbH & Co. KG, a subsidiary of Microchip Technology Inc., in other countries.

All other trademarks mentioned herein are property of their respective companies.

© 2019-2022, Microchip Technology Incorporated and its subsidiaries.

All Rights Reserved.

ISBN:978-1-6683-0777-9

Table of Contents

Preface	5
Introduction.....	5
Document Layout	5
Conventions Used in this Guide	6
Recommended Reading.....	7
The Microchip Website	7
Customer Support	7
Document Revision History	7
 Chapter 1. Product Overview	
1.1 Introduction	10
1.2 MCP16502 Short Overview	10
1.3 MCP16502 Evaluation Board Overview	11
1.4 Contents of the MCP16502 Evaluation Board Kit	11
 Chapter 2. Installation and Operation	
2.1 Introduction	12
2.2 Features	13
2.3 Getting Started	13
2.4 On-Board Load Transient Generator	15
2.5 Layout considerations	15
 Chapter 3. GUI Installation and Operation	
3.1 Getting started	16
3.2 Graphical User Interface Installation	16
3.3 I2C Monitor Graphical User Interface Uninstall	19
 Chapter 4. GUI Description	
4.1 Introduction	20
4.2 Graphical User Interface	21
 Appendix A. Schematic and Layouts	
A.1 Introduction	26
A.2 Board – Schematic	27
A.3 Board – Top Copper and Silk	28
A.4 Board – Mid-Layer 1	28
A.5 Board – Mid-Layer 2	29
A.6 Board – Bottom Copper and Silk	29
 Appendix B. Bill of Materials (BOM).....	30
Worldwide Sales and Service	32

MCP16502 Evaluation Board User's Guide

NOTES:

Preface

NOTICE TO CUSTOMERS

All documentation becomes dated, and this manual is no exception. Microchip tools and documentation are constantly evolving to meet customer needs, so some actual dialogs and/or tool descriptions may differ from those in this document. Please refer to our website (www.microchip.com) to obtain the latest documentation available.

Documents are identified with a “DS” number. This number is located on the bottom of each page, in front of the page number. The numbering convention for the DS number is “DSXXXXXXXXA”, where “XXXXXXXX” is the document number and “A” is the revision level of the document.

For the most up-to-date information on development tools, see the MPLAB® IDE online help. Select the Help menu, and then Topics to open a list of available online help files.

INTRODUCTION

This chapter contains general information that will be useful to know before using the MCP16502 Evaluation Board. Items discussed in this chapter include:

- [Document Layout](#)
- [Conventions Used in this Guide](#)
- [Recommended Reading](#)
- [The Microchip Website](#)
- [Customer Support](#)
- [Document Revision History](#)

DOCUMENT LAYOUT

This document describes how to use the MCP16502 Evaluation Board as a development tool. The manual layout is as follows:

- **Chapter 1. “Product Overview”** – Important information about the MCP16502 Evaluation Board.
- **Chapter 2. “Installation and Operation”** – Includes instructions on how to get started with the MCP16502 Evaluation Board and a description of each function.
- **Chapter 3. “GUI Installation and Operation”** – Includes instructions on how to install the Graphical User Interface.
- **Chapter 4. “GUI Description”** – Describes the items in the Graphical User Interface.
- **Appendix A. “Schematic and Layouts”** – Shows the schematic and layout diagrams for the MCP16502 Evaluation Board.
- **Appendix B. “Bill of Materials (BOM)”** – Lists the parts used to build the MCP16502 Evaluation Board.

MCP16502 Evaluation Board User's Guide

CONVENTIONS USED IN THIS GUIDE

This manual uses the following documentation conventions:

DOCUMENTATION CONVENTIONS

Description	Represents	Examples
Arial font:		
Italic characters	Referenced books	<i>MPLAB® IDE User's Guide</i>
	Emphasized text	...is the <i>only</i> compiler...
Initial caps	A window	the Output window
	A dialog	the Settings dialog
	A menu selection	select Enable Programmer
Quotes	A field name in a window or dialog	"Save project before build"
Underlined, italic text with right angle bracket	A menu path	<u><i>File>Save</i></u>
Bold characters	A dialog button	Click OK
	A tab	Click the Power tab
N'Rnnnn	A number in verilog format, where N is the total number of digits, R is the radix and n is a digit.	4'b0010, 2'hF1
Text in angle brackets < >	A key on the keyboard	Press <Enter>, <F1>
Courier New font:		
Plain Courier New	Sample source code	#define START
	Filenames	autoexec.bat
	File paths	c:\mcc18\h
	Keywords	_asm, _endasm, static
	Command-line options	-Opa+, -Opa-
	Bit values	0, 1
	Constants	0xFF, 'A'
Italic Courier New	A variable argument	<i>file.o</i> , where <i>file</i> can be any valid filename
Square brackets []	Optional arguments	mcc18 [options] <i>file</i> [options]
Curly brackets and pipe character: { }	Choice of mutually exclusive arguments; an OR selection	errorlevel {0 1}
Ellipses...	Replaces repeated text	var_name [, var_name...]
	Represents code supplied by user	void main (void) { ... }

RECOMMENDED READING

This user's guide describes how to use the MCP16502 Evaluation Board. Another useful document is listed below. The following Microchip document is available and recommended as a supplemental reference resource.

- **MCP16502 Data Sheet – “High-Performance PMIC for SAMA5DX/SAM9X6/SAMA7G Series MPUs” (DS20006275)**

THE MICROCHIP WEBSITE

Microchip provides online support via our website at www.microchip.com. This website is used as a means to make files and information easily available to customers. Accessible by using your favorite Internet browser, the website contains the following information:

- **Product Support** – Data sheets and errata, application notes and sample programs, design resources, user's guides and hardware support documents, latest software releases and archived software
- **General Technical Support** – Frequently Asked Questions (FAQs), technical support requests, online discussion groups, Microchip consultant program member listing
- **Business of Microchip** – Product selector and ordering guides, latest Microchip press releases, listing of seminars and events, listings of Microchip sales offices, distributors and factory representatives

CUSTOMER SUPPORT

Users of Microchip products can receive assistance through several channels:

- Distributor or Representative
- Local Sales Office
- Field Application Engineer (FAE)
- Technical Support

Customers should contact their distributor, representative or field application engineer (FAE) for support. Local sales offices are also available to help customers. A listing of sales offices and locations is included in the back of this document.

Technical support is available through the website at:
<http://www.microchip.com/support>.

DOCUMENT REVISION HISTORY

Revision F (June 2022)

- Updated [Figure 2-1: “MCP16502 Evaluation Board with MCP2221 I2C Bridge.”](#)

Revision E (June 2022)

- Minor typographical changes.

Revision D (April 2021)

- Added the Automotive AEC-Q100 Reliability test pass feature to [Section 1.2 “MCP16502 Short Overview”](#) and [Section 2.2 “Features”](#).

Revision C (December 2019)

- Revised data sheet title.

MCP16502 Evaluation Board User's Guide

Revision B (November 2019)

- Removed AEC-Q100 reference.

Revision A (November 2019)

- Initial release of this document.

Chapter 1. Product Overview

1.1 INTRODUCTION

This chapter provides an overview of the MCP16502 Evaluation Board and covers the following topics:

- [MCP16502 Short Overview](#)
- [MCP16502 Evaluation Board Overview](#)
- [Contents of the MCP16502 Evaluation Board Kit](#)

1.2 MCP16502 SHORT OVERVIEW

The MCP16502 is an optimally integrated PMIC compatible with Microchip's eMPUs (Embedded Microprocessor Units), requiring Dynamic Voltage Scaling (DVS), with the use of High-Performance mode (HPM). It is compatible with SAMA5DX and SAM9x6 MPUs, supported by dedicated device variants which optimize the solution BOM.

The MCP16502 integrates four DC-DC buck regulators and two auxiliary LDOs and provides a comprehensive interfacing to the MPU, which includes an interrupt flag and a 1 MHz I²C interface.

All buck channels can support loads up to 1A. All bucks are 100% duty cycle capable.

Two 300 mA LDOs are provided such that sensitive analog loads can be supported.

The DDR memory voltage (Buck2) is selectable by means of a tri-state input pin. This method allows greater precision in the output voltage setting by eliminating inaccuracies due to external feedback resistors, while minimizing external component count. The voltages selection set allows easy migration across different generations of memories.

The default power channel sequencing is built-in, according to the requirements of the MPU. A dedicated pin (LPM) facilitates the transition to low-power modes and the implementation of the Backup mode with DDR in self-refresh (Hibernate mode).

The MCP16502 features a low, no-load operational quiescent current and it draws less than 10 μ A in full shutdown.

Active discharge resistors are provided on each output. All buck channels support safe start-up into pre-biased outputs.

The MCP16502 is available in a 32-pin 5 mm x 5 mm VQFN package, with an operating junction temperature range from -40°C to $+125^{\circ}\text{C}$.

The MCP16502 also passes automotive AEC-Q100 reliability testing.

MCP16502 Evaluation Board User's Guide

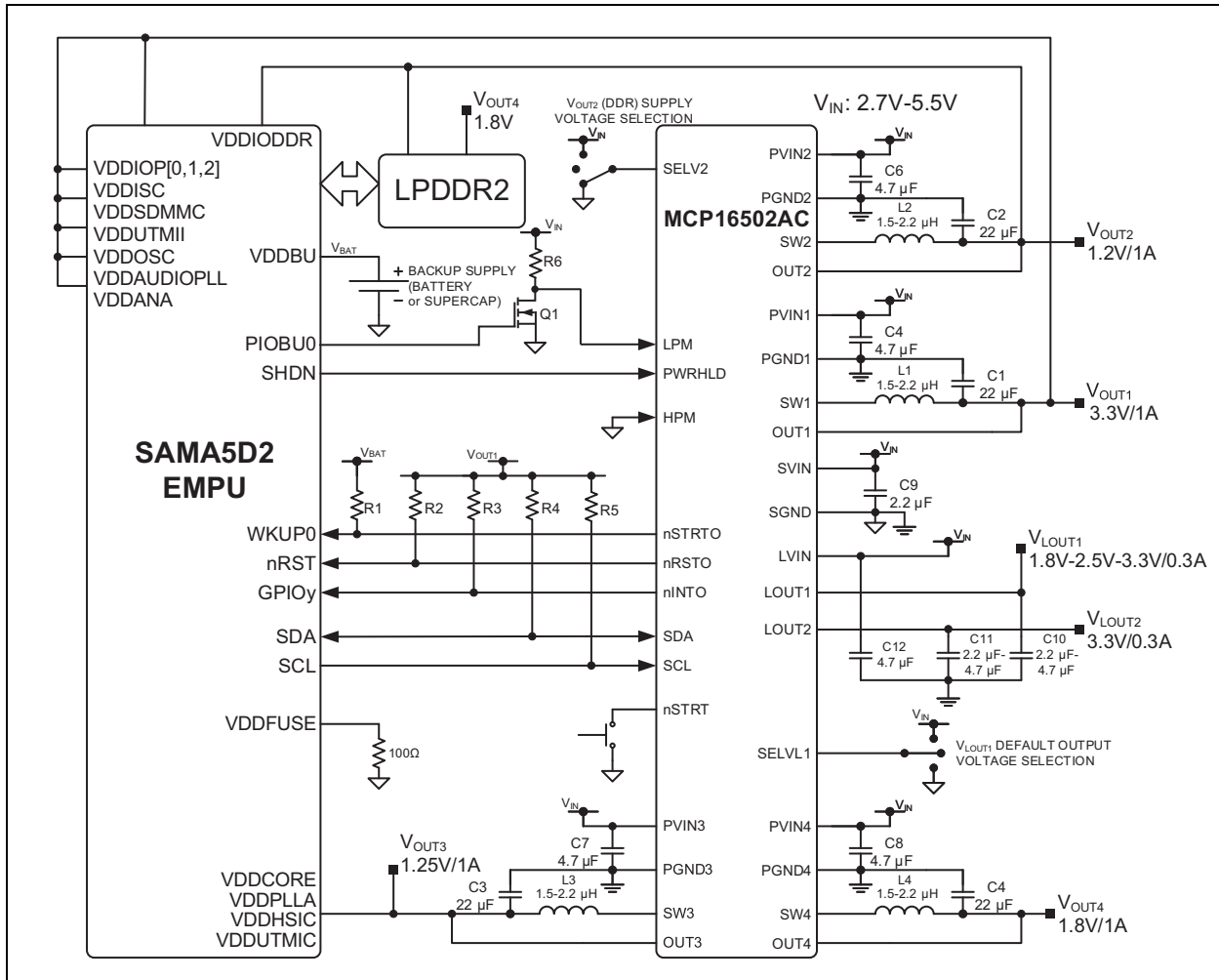

FIGURE 1-1: Typical MCP16502AC with SAMA5D2 and LPDDR2 Application.

1.3 MCP16502 EVALUATION BOARD OVERVIEW

The MCP16502 Evaluation Board is designed to simplify the evaluation and testing of all the MCP16502 capabilities. The V_{IN} supply has a 2.7V-5.5V range and V_{OUT} has a 1.2V-3.7V range for Buck1 and the two LDOs and 0.6-1.85V for Buck2, Buck3 and Buck4.

An on-board MCP2221, which is a USB 2.0 to I²C/UART Protocol Converter with GPIO, is placed on the board to simplify the configuration of the MCP16502.

The application allows for both manual control of power state pins through 3-pin jumpers on PWRHLD, LPM and HPM pins and software control using the I²C Monitor GUI.

Additionally, an on-board load transient generator circuit is provided to evaluate the load step response of some of the buck channels.

1.4 CONTENTS OF THE MCP16502 EVALUATION BOARD KIT

The MCP16502 Evaluation Board kit includes:

- MCP16502 Evaluation Board (DT100105)
- USB-to-Micro-USB Cable
- Important Information Sheet

Chapter 2. Installation and Operation

2.1 INTRODUCTION

The MCP16502 Evaluation Board has been developed to test the MCP16502's capabilities, control and monitor through the USB interface (via the I²C Monitor GUI).

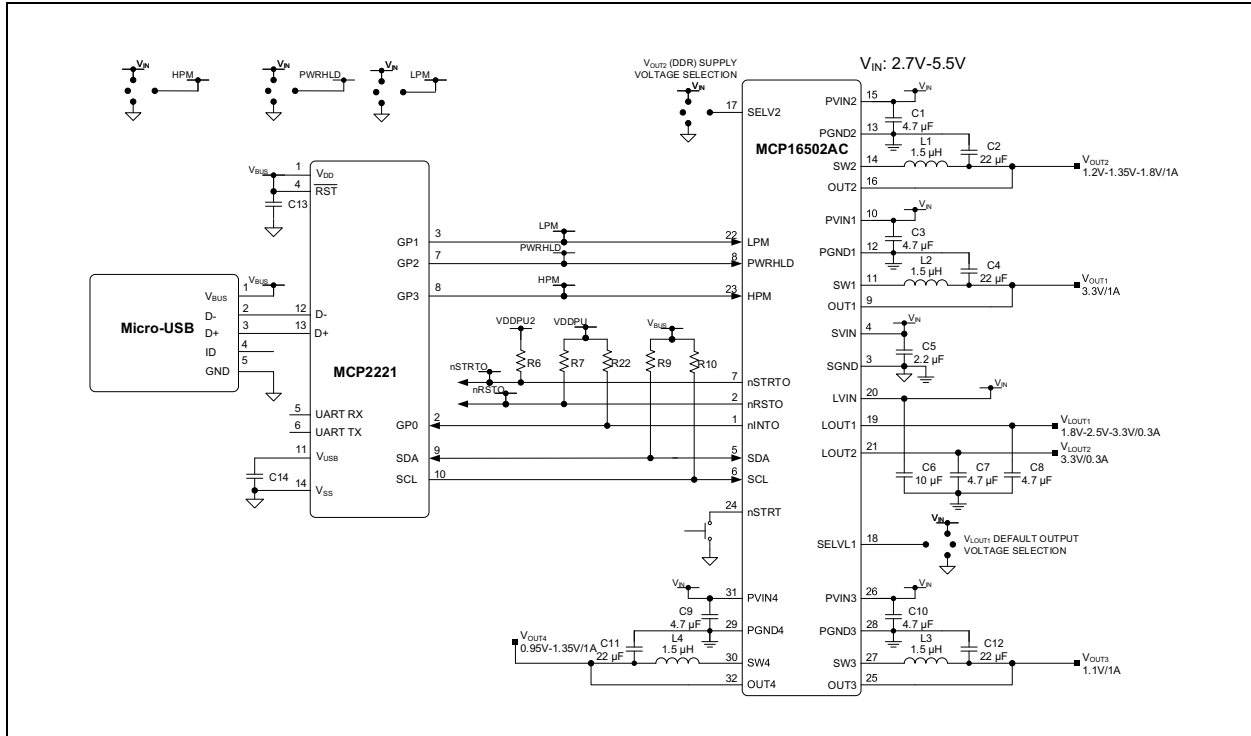

FIGURE 2-1: MCP16502 Evaluation Board with MCP2221 I²C Bridge.

MCP16502 Evaluation Board User's Guide

2.2 FEATURES

The MCP16502 Evaluation Board has the following features:

- Input Voltage Range: 2.7V to 5.5V
- Four 1A Buck DC-DC Channels with 100% Maximum Duty Cycle Capability
- 2 MHz Buck Channels PWM Operation
- Two Auxiliary 300 mA LDOs
- $\pm 1\%$ Voltage Accuracy for DDR (Buck2), Core (Buck3) and CPU (Buck4)
- Pin-Selectable Output Voltages for DDR Buck: 1.2V, 1.35V, 1.8V
- MPU-Specific Built-In Default Channel Sequencing and nRSTO Assertion Delay
- Support of Hibernate, Low-Power and High-Performance Modes with DVS
- 1 MHz I²C Interface for Programming and Diagnostics
- Low-Noise Forced PWM (FPWM) and Low Quiescent Current Light Load High-Efficiency Mode
- Leakage-Free Interfacing to MPU in any Operating Condition through Optimized ESD Protection
- Less than 300 μ A Low-Power Mode Typical Quiescent Current (Bucks and LDO1 on, no load)
- 10 μ A Maximum Shutdown Current ($V_{IN} = 4.5V$, $T_J = +105^\circ C$)
- Cost and Size-Optimized BOM
- Thermal Shutdown and Current-Limit Protection
- User-Programmable Overcurrent Fault Response
- 32-pin 5 mm \times 5 mm VQFN Package
- $-40^\circ C$ to $+125^\circ C$ Junction Temperature Range
- Passes Automotive AEC-Q100 Reliability Testing

2.3 GETTING STARTED

The MCP16502 Evaluation Board is fully assembled and tested to evaluate and demonstrate the MCP16502 product.

This board requires a single power supply with at least 3A current capability if multiple channels are tested under load. The MCP16502 Evaluation Board can be powered directly from the USB connector by connecting jumper J1. Note that in this configuration, the amount of power which can be supplied at the outputs is limited by the USB connection. This is only meant for testing using the GUI of the sequencing and different register settings.

The MCP16502 is available in five different product options, depending on the default settings at power-up, prior to any I²C write operation. The differences among the various product options are described in the MCP16502 data sheet. The Evaluation Board carries the AC option, which is intended for an efficiency-optimized, high-performance (i.e., 500 MHz) SAMA5D2 application, equipped with LPDDR2 memories.

2.3.1 Power Input and Output Connections

To power up the MCP16502 Evaluation Board, follow the steps below:

1. Connect a power supply to the MAIN and PGND terminals. An ammeter may be placed between the input supply and the MAIN terminal to the Evaluation Board. Ensure that the supply voltage is monitored at the MAIN terminal. The ammeter and/or power lead resistance can reduce the voltage supplied to the input.

Note: Keep the power supply disabled; do not apply power before Step 5.

2. Connect the loads to the VOUTx for buck converters or LDOx for LDO regulators and PGND terminals. The load can be either passive (resistive) or active (electronic load). An ammeter can be placed between the load and each output terminal. Ensure that the output voltage is monitored at the output terminals. Alternatively, for high-speed load transient testing at low output voltages, the on-board load transient generator can be used (see [Section 2.4 “On-Board Load Transient Generator”](#)).
3. Make sure the jumpers are connected as in [Figure 2-2](#) (PWRHLD = HPM = LPM = SELVL1 = SELV2 = HIGH and optionally VDDPU2 = VIN). If experimenting with the connection VDDPU2 = VDDBAT, make sure to remove R3 prior to that.
4. If changing the PMIC parameters is required or simply to monitor the part, make sure to connect the Micro-USB cable between the Evaluation Board and the PC.

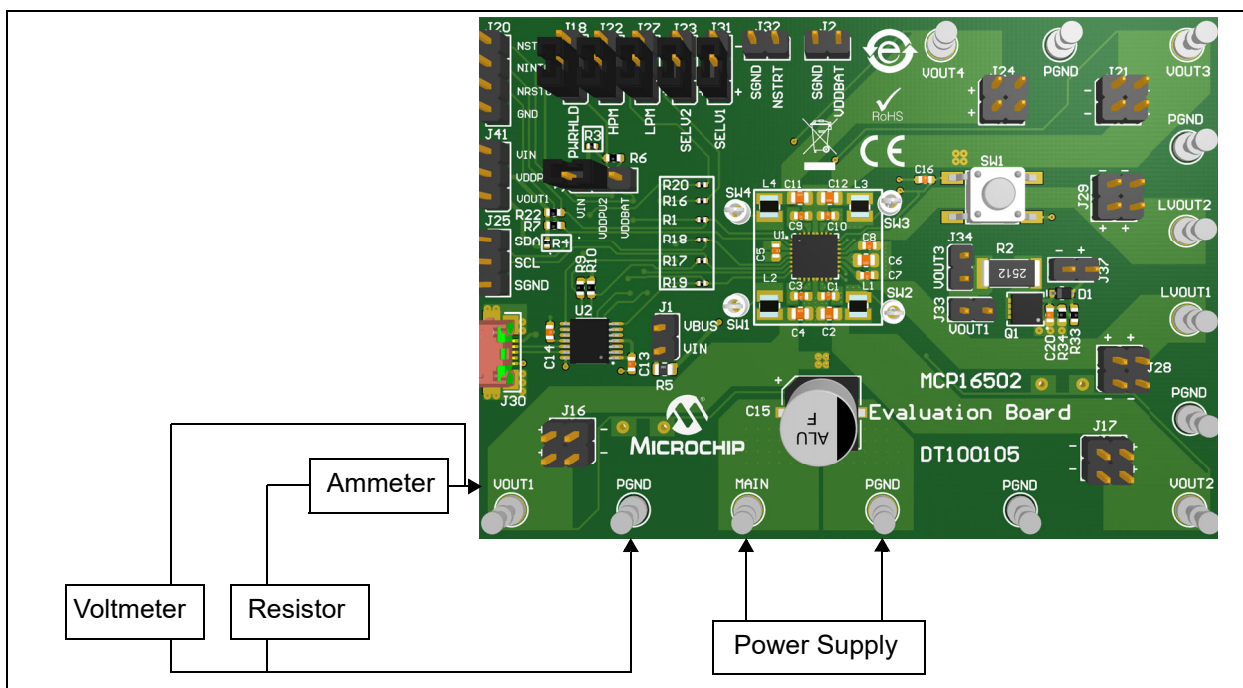

FIGURE 2-2: MCP16502 Evaluation Board Connection.

5. Set the power supply to 5V and turn it on. Alternatively, if no power supply is available, a jumper can be connected to J1, such that the board is powered from the USB connection.
6. Press the **SW1** button.
7. Verify that the output voltages are regulated to the desired VOUT setting for each channel.
8. The PMIC settings can be modified using the GUI. For details on how to use the I²C Monitor, see [Section 3.3 “I²C Monitor Graphical User Interface Uninstall”](#).

MCP16502 Evaluation Board User's Guide

2.4 ON-BOARD LOAD TRANSIENT GENERATOR

The MCP16502 Evaluation Board provides circuitry to enable load transient testing with fast current rise time and fast, yet controlled, fall time. This is done by a fast turn-on, controlled turn-off MOSFET switch (Q1). MOSFET Q1 must be driven by an external signal generator, connected at J37, using a square wave (the suggested low level is 0V, the high level is 5V-6V). Drive levels can be adjusted to modify the switching speed of Q1, but should always ensure complete turn-on and turn-off of Q1 after settling, while not exceeding its V_{GS} ratings. By default, the R2 resistor is 4.7Ω , with a power dissipation rating of 1W. It is very important not to exceed the power dissipation limit of R2. When using the 2512 resistor (1W rating), the constraint is:

EQUATION 2-1:

$$D \times \frac{V_{OUT}^2}{R2} < 1W$$

Where:

D = The on-time duty cycle of Q1

V_{OUT} = The selected output voltage

The on-board load transients generator can be used to test either Buck1, by connecting a jumper to J33, or Buck3, by connecting a jumper to J34.

The on-board load transient generator is especially useful when testing at very low output voltages, since not many active loads can perform well under those conditions, while current rise times achievable with external load boards are limited by stray inductance.

2.5 LAYOUT CONSIDERATIONS

The MCP16502 PMIC requires at least nine vias from the ICs Exposed Pad to the ground (GND) plane, to dissipate the generated heat. The GND plane can be increased or decreased based on the ambient temperature, air flow or other devices that generate heat. The rule of thumb is that the GND plane must be as big as possible.

The MCP16502 also features power ground (PGND) pins that must be connected to the power components (power input and output capacitors) and to a low-impedance return path, such as a dedicated plane or copper pour. It is also recommended to connect the input and output capacitor GND connections, as well as the PGND pins on the same layer (thus avoiding vias inductance) and the same continuous copper plane for optimal performance.

The PGND pins and GND planes should be connected together at the Exposed Pad. See [Appendix A. "Schematic and Layouts"](#) for a PCB layout example.

For low EMI (Electromagnetic Interference) emissions, the switching node of the Buck regulators should be routed on an internal plane, surrounded/enclosed by input supply voltage distribution or GND planes.

Chapter 3. GUI Installation and Operation

3.1 GETTING STARTED

To install, use and evaluate the product, several software and hardware tools are required.

3.1.1 Required Software

- I²C Monitor Graphical User Interface 5.0 or higher
- Microsoft® .NET Framework 4.5 or higher
- Adobe® Reader®
- Windows® 7 or 10

3.1.2 Required Hardware

- MCP16502 Evaluation Board
- USB-to-Micro-USB Cable

3.2 GRAPHICAL USER INTERFACE INSTALLATION

The following steps describe how to install the I²C Monitor Graphical User Interface:

1. If Microsoft .NET Framework is already installed, go to [Step 3](#). If not, download Microsoft .NET Framework from www.microsoft.com and follow the installation instructions.
2. If Adobe Reader is already installed, go to [Step 3](#). If not, download Adobe Reader from <http://get.adobe.com/reader/> and follow the installation instructions.
3. Download the I²C Monitor Graphical User Interface archive from the product web page under “Documentation”.
4. Unzip the I²C Monitor Graphical User Interface archive, which contains the `setup.exe` file.

Note: If an older version or a corrupted version of the current I²C Monitor Graphical User Interface is already installed on the computer, see [Section 3.3 “I²C Monitor Graphical User Interface Uninstall”](#) before proceeding with the installation.

5. Double click the `setup.exe` file to open the Install Shield Wizard window and wait for the extraction to complete. If required, the installation can be stopped by pressing the **Cancel** button.

MCP16502 Evaluation Board User's Guide

6. In the Welcome to the InstallShield Wizard for I2CMonitor window, click the **Next** button to start the installation.

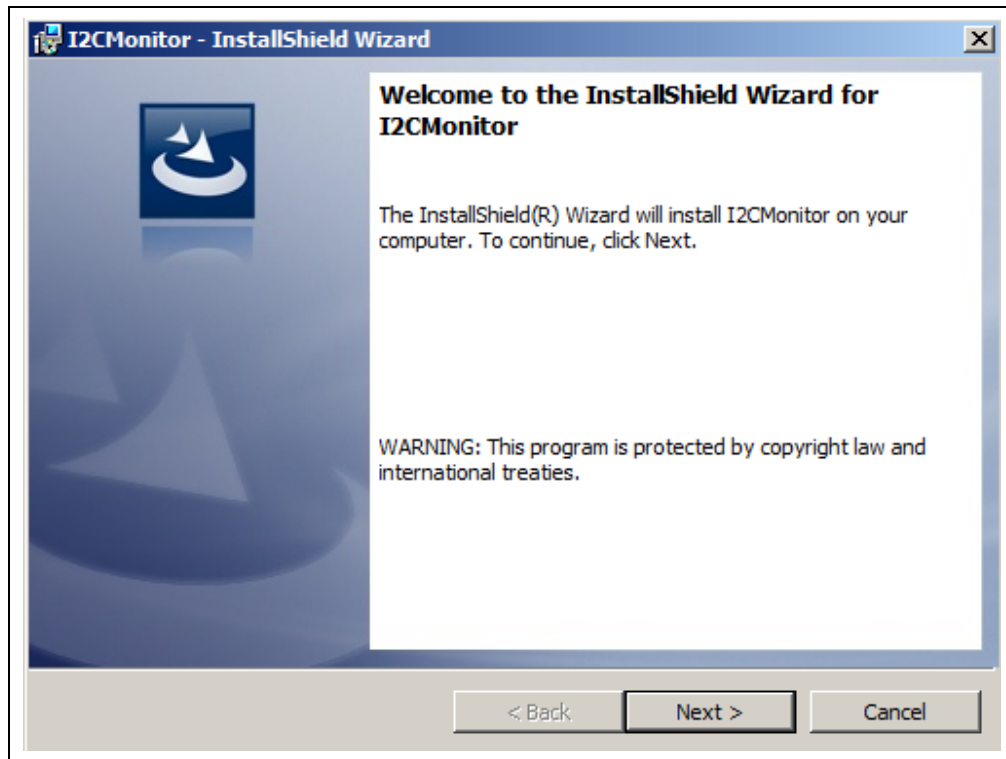

FIGURE 3-1: Starting the I²C Monitor Graphical User Interface Installation.

7. The installation path can be changed, although it is recommended to keep the default path. Click **Next** to continue.

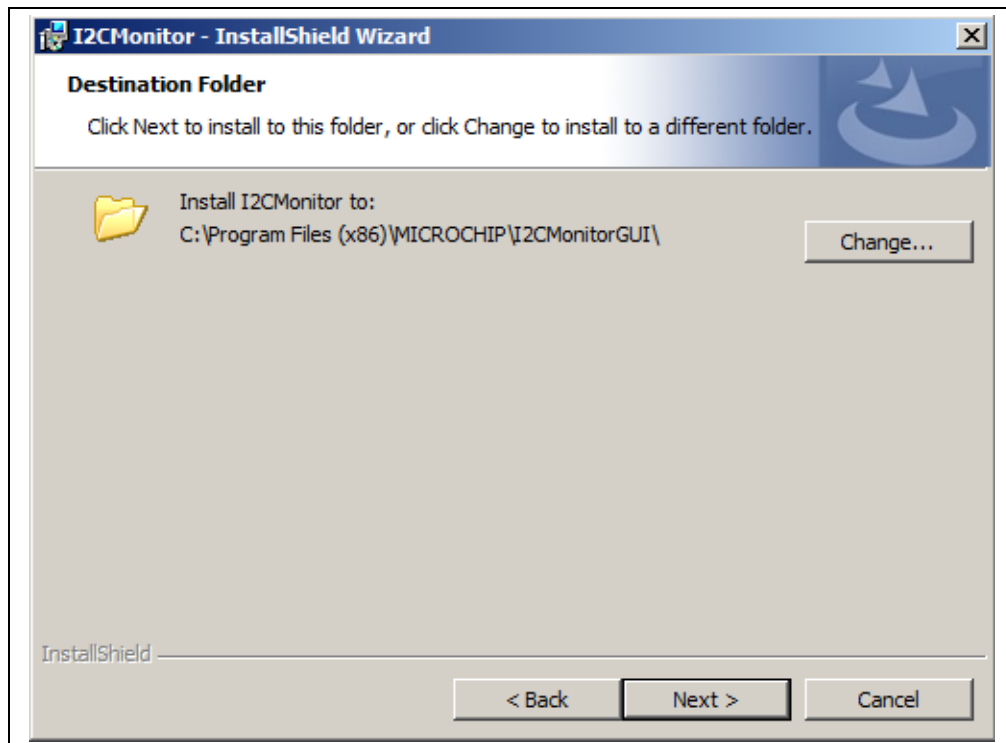

FIGURE 3-2: Selecting the Destination Folder.

GUI Installation and Operation

8. In the Ready to Install the Program window, click the **Install** button and wait for the application to proceed with the installation.

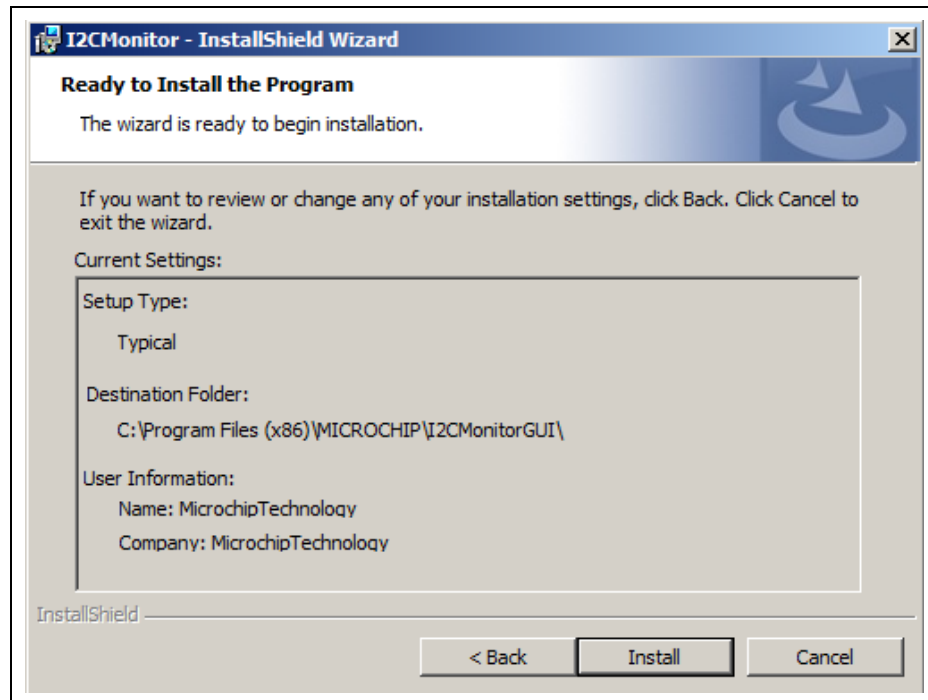

FIGURE 3-3: *Installing the I²C Monitor Graphical User Interface.*

9. Once the installation is complete, click **Finish** to end the installation. To start the GUI, either click the desktop icon or browse to Windows Start>All Programs>Microchip>I2C Monitor.

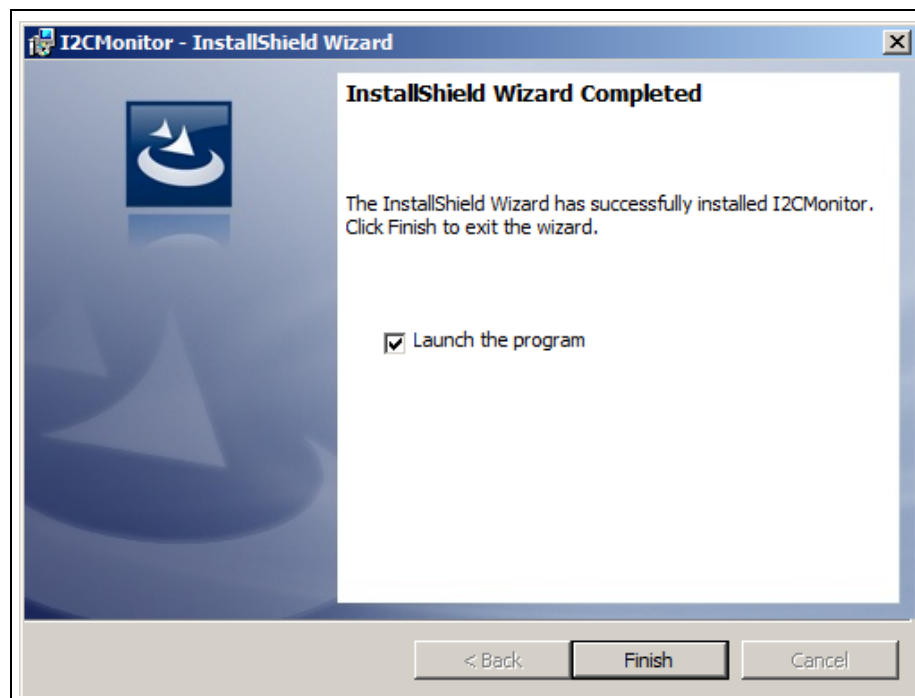

FIGURE 3-4: *InstallShield Wizard Completed Window.*

MCP16502 Evaluation Board User's Guide

3.3 I²C MONITOR GRAPHICAL USER INTERFACE UNINSTALL

To install a new version of the I²C Monitor Graphical User Interface, any previous or corrupted version must be removed from the computer.

To uninstall, go to *Windows Start>Control Panel>Uninstall a program>I2C Monitor*.

The I²C Monitor will automatically close once the process is complete.

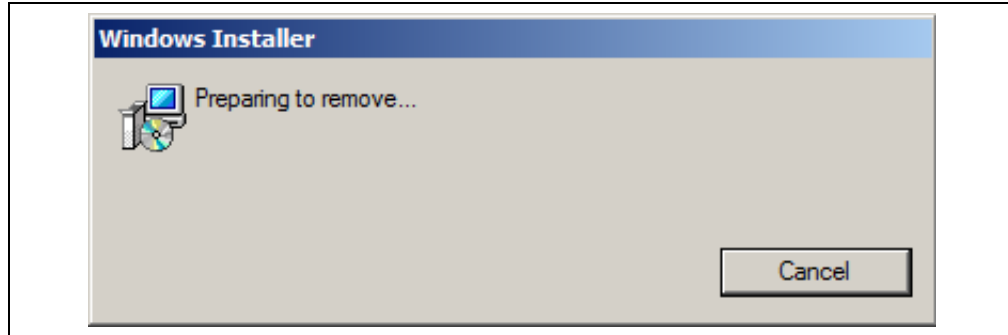

FIGURE 3-5: *Uninstalling the I²C Monitor Graphical User Interface.*

Chapter 4. GUI Description

4.1 INTRODUCTION

This chapter describes how to use the I²C Monitor Graphical User Interface using the MCP16502 Evaluation Board.

NOTICE

This chapter provides information regarding the use of the GUI in the case of the MCP16502. For other devices using the I²C Monitor Graphical User Interface, see their specific Data Sheets and User's Guides.

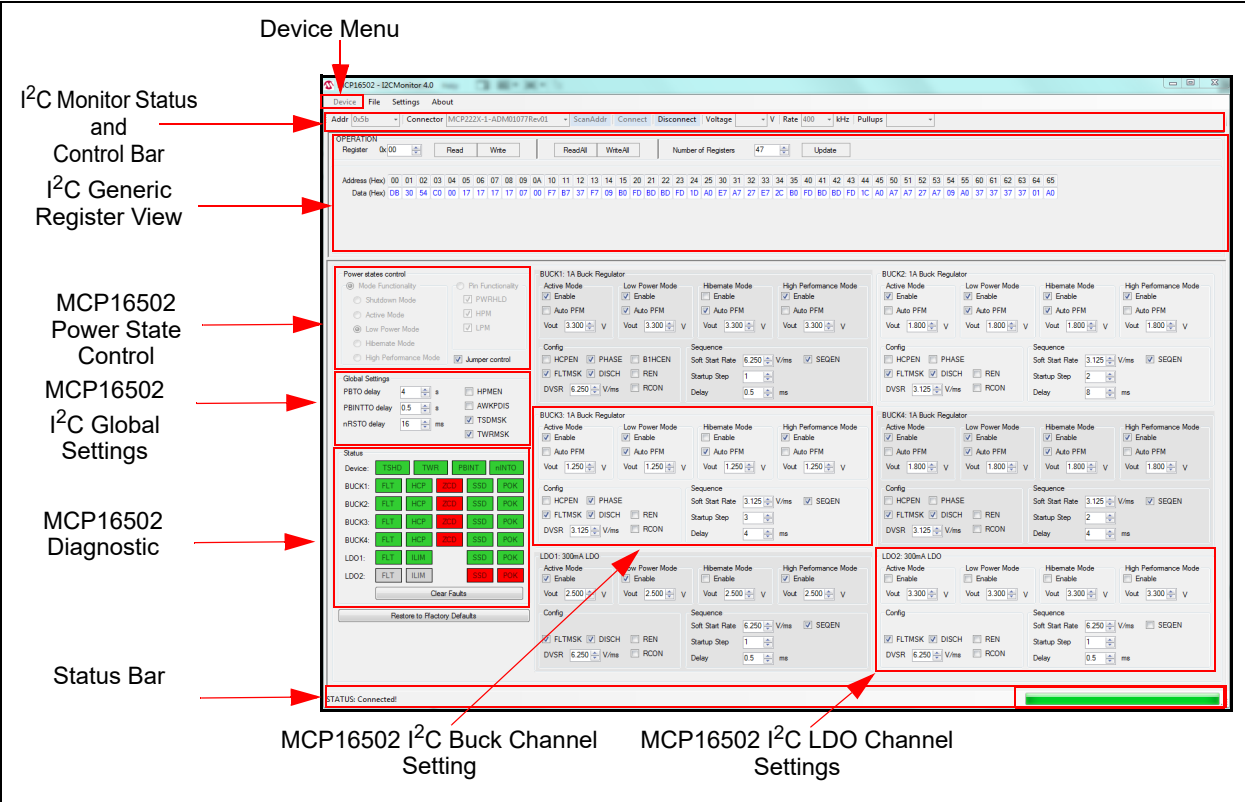

The screenshot shows the MCP16502 I²C Monitor GUI. Key components are annotated as follows:

- Device Menu:** Located at the top left of the application window.
- I²C Monitor Status and Control Bar:** The top section of the main window, containing a menu bar and a toolbar.
- I²C Generic Register View:** A table showing I²C register addresses (0x00 to 0x4F) and their corresponding data values.
- MCP16502 Power State Control:** A section with radio buttons for Mode Functionality (Shutdown, Active, Low Power, Hibernation) and checkboxes for Pin Functionality (PWRHLD, HPM, LPM, High Performance Mode, Jumper control).
- MCP16502 I²C Global Settings:** A section with input fields for PBNTTO delay (4 s), hRSTO delay (16 ms), and checkboxes for HPMBEN, AWKPDIS, TSDMSK, and TWPMSK.
- MCP16502 Diagnostic:** A grid of colored status indicators for various components: Device, BUCK1, BUCK2, BUCK3, BUCK4, LD01, and LD02.
- Status Bar:** Located at the bottom of the window, showing 'STATUS: Connected!' and a progress indicator.
- MCP16502 I²C Buck Channel Setting:** A detailed configuration panel for Buck regulators (BUCK1, BUCK2, BUCK3, BUCK4), including Active Mode, Low Power Mode, Hibernation Mode, High Performance Mode, Auto PFM, and various configuration parameters like Soft Start Rate, Status Step, and Delay.
- MCP16502 I²C LDO Channel Settings:** A detailed configuration panel for LDO regulators (LD01, LD02), including Active Mode, Low Power Mode, Hibernation Mode, High Performance Mode, and configuration parameters like Soft Start Rate, Status Step, and Delay.

FIGURE 4-1: I²C Monitor Graphical User Interface Main Window - MCP16502 View.

MCP16502 Evaluation Board User's Guide

4.2 GRAPHICAL USER INTERFACE

4.2.1 Device Menu

The Device drop-down menu allows the user to select the device to be evaluated.

4.2.2 I²C Monitor Status and Control

The “Status and Control” bar contains the items described in [Table 4-1](#).

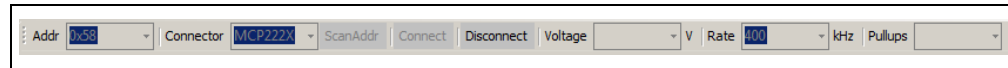

FIGURE 4-2: I²C Monitor Status and Control Bar.

TABLE 4-1: MONITOR STATUS AND CONTROL BAR

Item	Description
Addr	This drop-down menu shows the address of the available devices.
Connector	This drop-down menu shows the type of connector used to connect the board.
ScanAddr	This button is used to scan for a valid address.
Connect/Disconnect	These buttons are used to connect/disconnect the current selected device.
Voltage	This drop-down menu is used to select the voltage level of the communication when using the PICKit™ Serial Analyzer.
Rate	This drop-down menu is used to select the corresponding communication rate for the device.
Pull-ups	This drop-down menu is used to activate the internal pull-ups from the PICKit™ Serial Analyzer.

In the “Status and Control” bar, the user can select the hardware tool for communicating with the device and the setting it should allow.

To connect to a device, the user must first follow the first three steps described in [Section 2.3 “Getting Started”](#). After connecting the Micro-USB cable, the user must scan for a valid address. Once a valid address is detected, clicking the **Connect** button initializes the connection with the device and the registers are available for read and write operations.

4.2.3 I²C Generic Register View

The I²C Generic Register View area contains the items described in [Table 4-2](#). This section of the I²C Monitor GUI is common for any device evaluated.

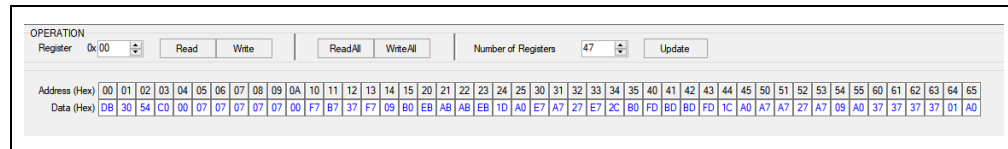

FIGURE 4-3: Generic Register View Area.

TABLE 4-2: I²C GENERIC REGISTER VIEW ITEMS

Panel	Item	Description
Operation	Register	This section shows the registers available for read/write operations.
	Read/Write	These buttons are used for single register read/write operations.
	ReadAll/WriteAll	These buttons are used for reading/writing all the available registers.
	Number of Registers	In this section, the user can set the number of available registers for read/write operations.
	Update	This button sets the number of available registers for read/write operations in the Register Area.
Register Area		This section shows the current status of the registers address and the content.

The MCP16502 specific registers are described in the MCP16502 data sheet.

4.2.4 MCP16502 Power State Control

The MCP16502 power states control area of the GUI allows the visualization or control of the device's power states.

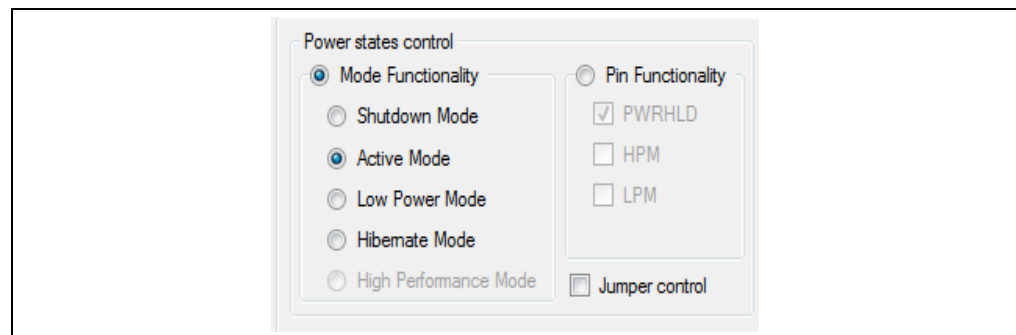

FIGURE 4-4: Power States Control Area.

The GUI allows the visualization of the control pins state (PWRHLD, HPM, LPM) and the associated power state if “Jumper control” is activated, or to set the actual mode if “Jumper control” is not activated.

For the relation between each pin status and the corresponding mode, refer to the data sheet.

4.2.5 MCP16502 I²C Global Settings

This region of the GUI allows the user to modify the device global features.

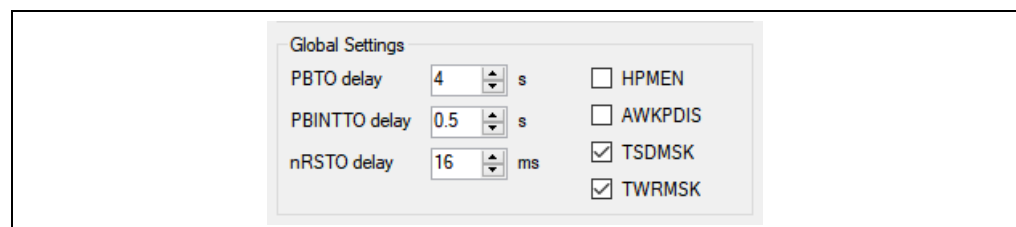

FIGURE 4-5: Global Settings.

MCP16502 Evaluation Board User's Guide

4.2.6 MCP16502 I²C Diagnostic

The MCP16502 I²C Diagnostic part of the GUI resumes the information contained in the STATUS register.

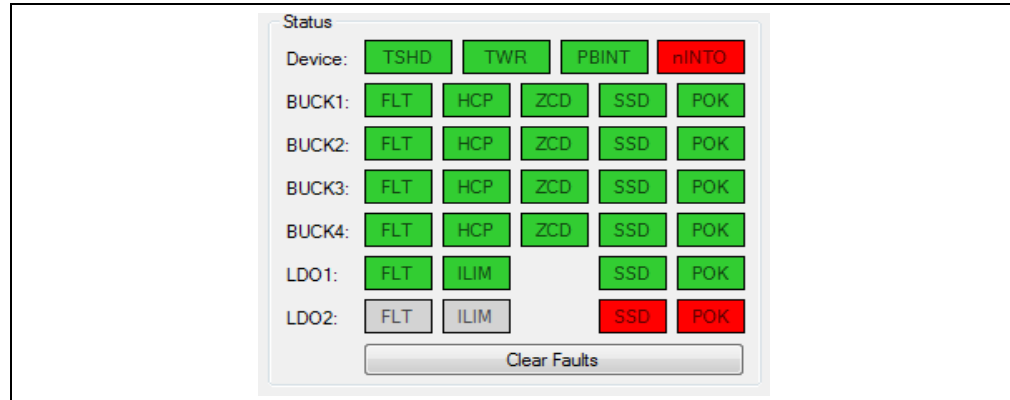

FIGURE 4-6: I²C Diagnostic Area.

This region marks the status and faults of each corresponding bits in the registers. In the case of the SSD and POK status flags, green signals a '1' condition and red signals a '0' condition. In the case of the TSHD, TWR, PBINT, nINTO, FLT, HCP, ZCD and ILIM Fault flags, green signals a '0' condition and red signals a '1' condition or an active Fault.

This information is refreshed once every two seconds. All Fault flags are reset on read, so the GUI memorizes the apparition of a Fault. To clear them from the GUI, the **Clear Faults** button must be clicked.

4.2.7 MCP16502 I²C Buck Channel Settings

This area of the GUI allows the user to modify the buck related features individually for each of the four buck channels.

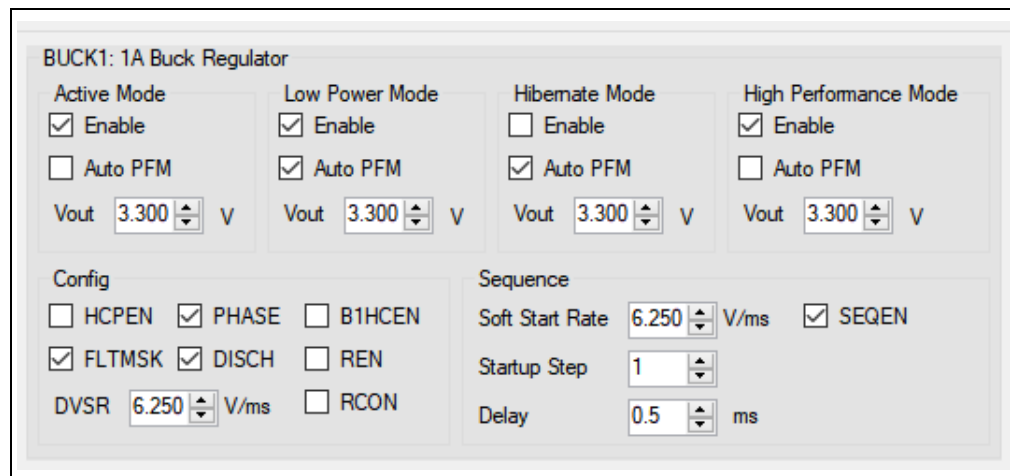

FIGURE 4-7: I²C Buck Channel Settings.

4.2.8 MCP16502 I²C LDO Channel Settings

This area of the GUI allows the user to modify the buck related features individually for each of the two LDO channels.

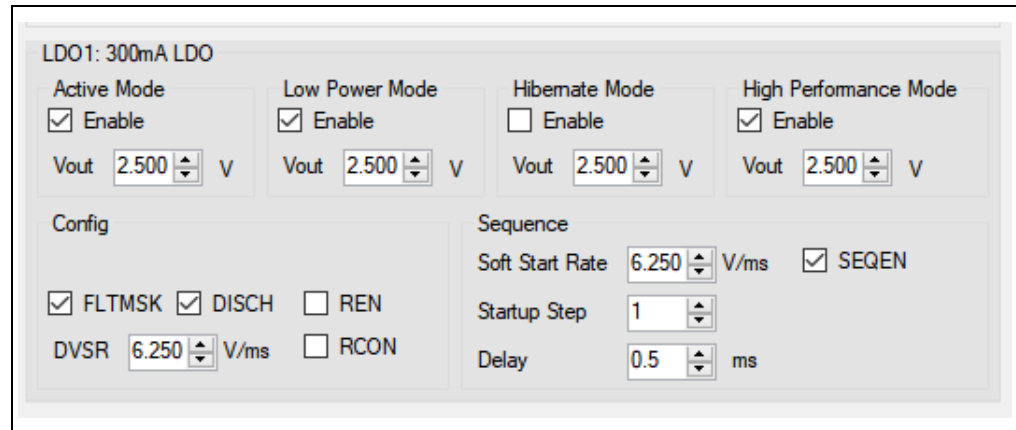

FIGURE 4-8: I²C LDO Channel Settings.

4.2.9 Status Bar

The status bar provides information on the status of the device connected to the PC.



FIGURE 4-9: Status Bar.

TABLE 4-3: STATUS BAR ITEMS

Item	Description
Status Label	The label shows if there is any device connected to the board. Refer to Table 4-4 for a list of possible labels.
Progress Bar	This bar shows the level of completion for a given command.

TABLE 4-4: STATUS LABELS

Status Label	Description
STATUS: Connected!	This message is shown when the GUI connects to a device.
STATUS: Disconnected!	This message is shown when the GUI does not detect a connected device.

The specific settings for all control areas are detailed in the register map available in the MCP16502 data sheet.

MCP16502 Evaluation Board User's Guide

NOTES:

Appendix A. Schematic and Layouts

A.1 INTRODUCTION

This appendix contains the following schematic and layouts for the MCP16502 Evaluation Board:

- [Board – Schematic](#)
- [Board – Top Copper and Silk](#)
- [Board – Mid-Layer 1](#)
- [Board – Mid-Layer 2](#)
- [Board – Bottom Copper and Silk](#)

A.3 BOARD – TOP COPPER AND SILK

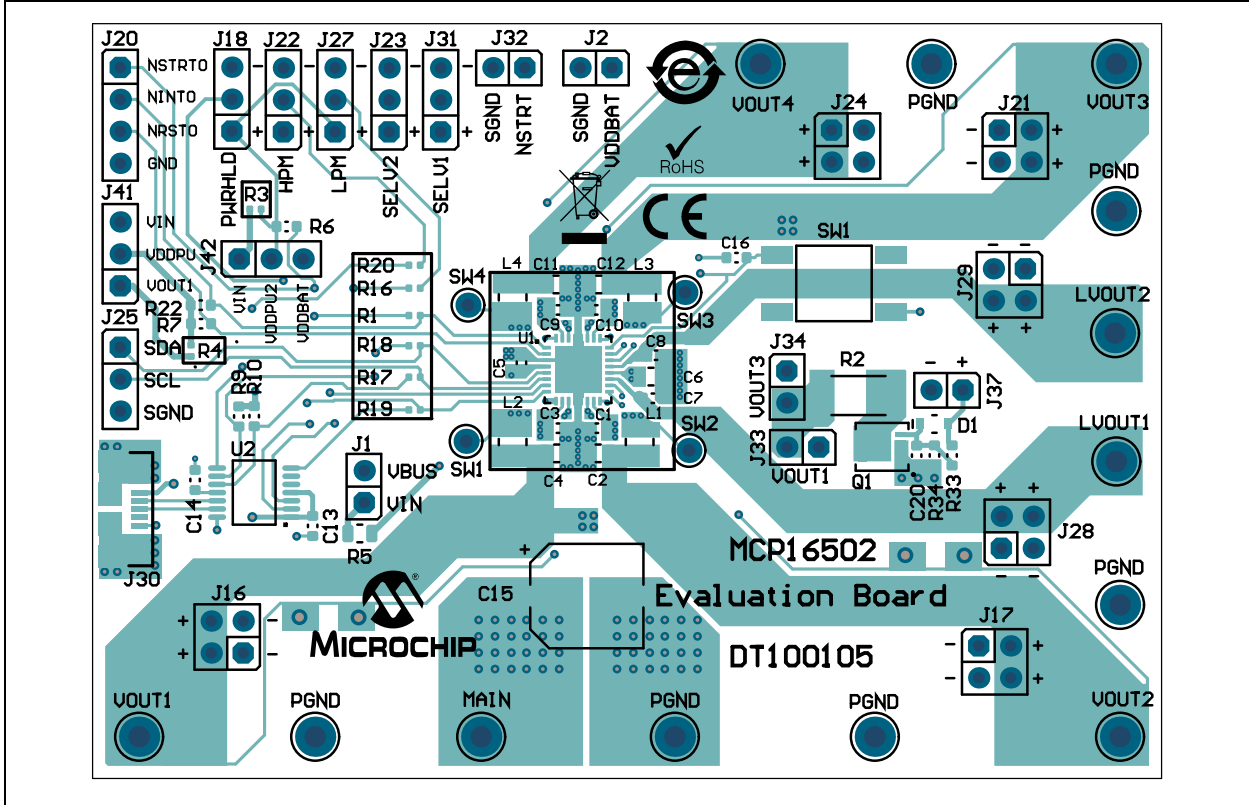

A.4 BOARD – MID-LAYER 1

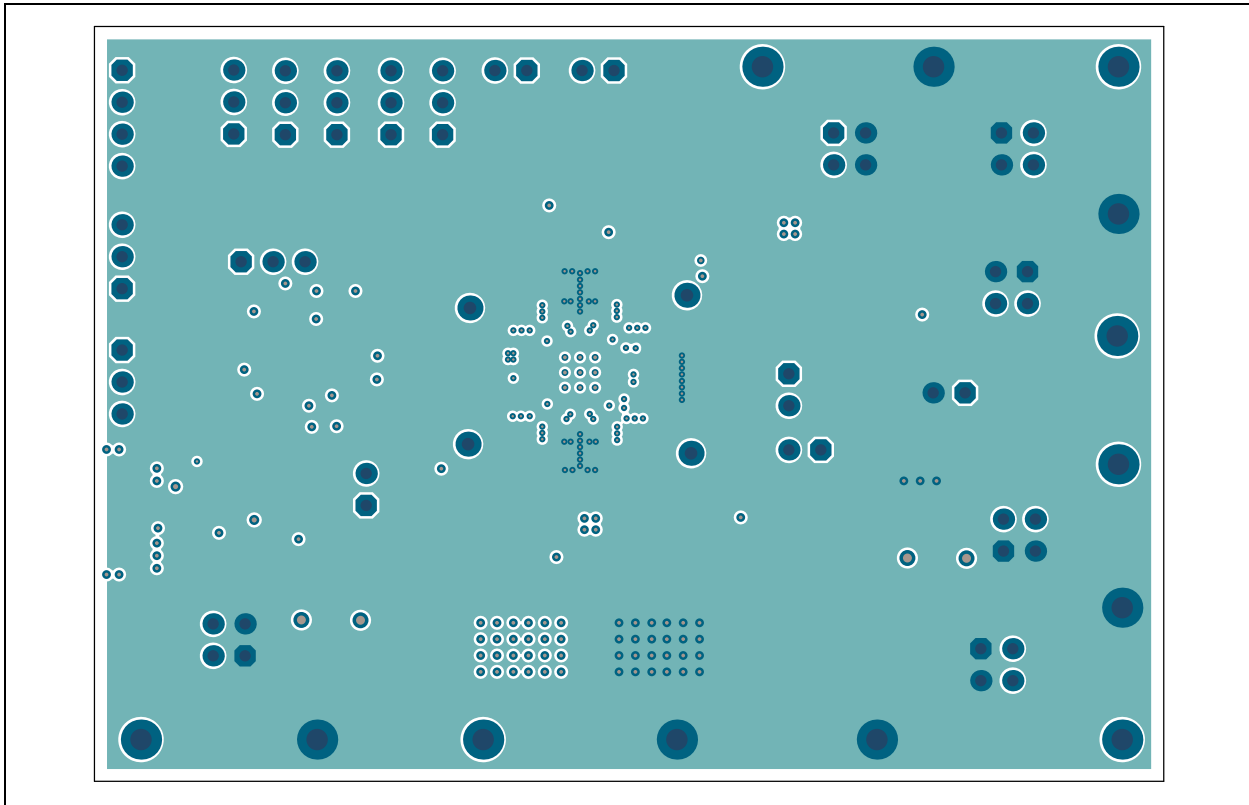

MCP16502 Evaluation Board User's Guide

A.5 BOARD – MID-LAYER 2

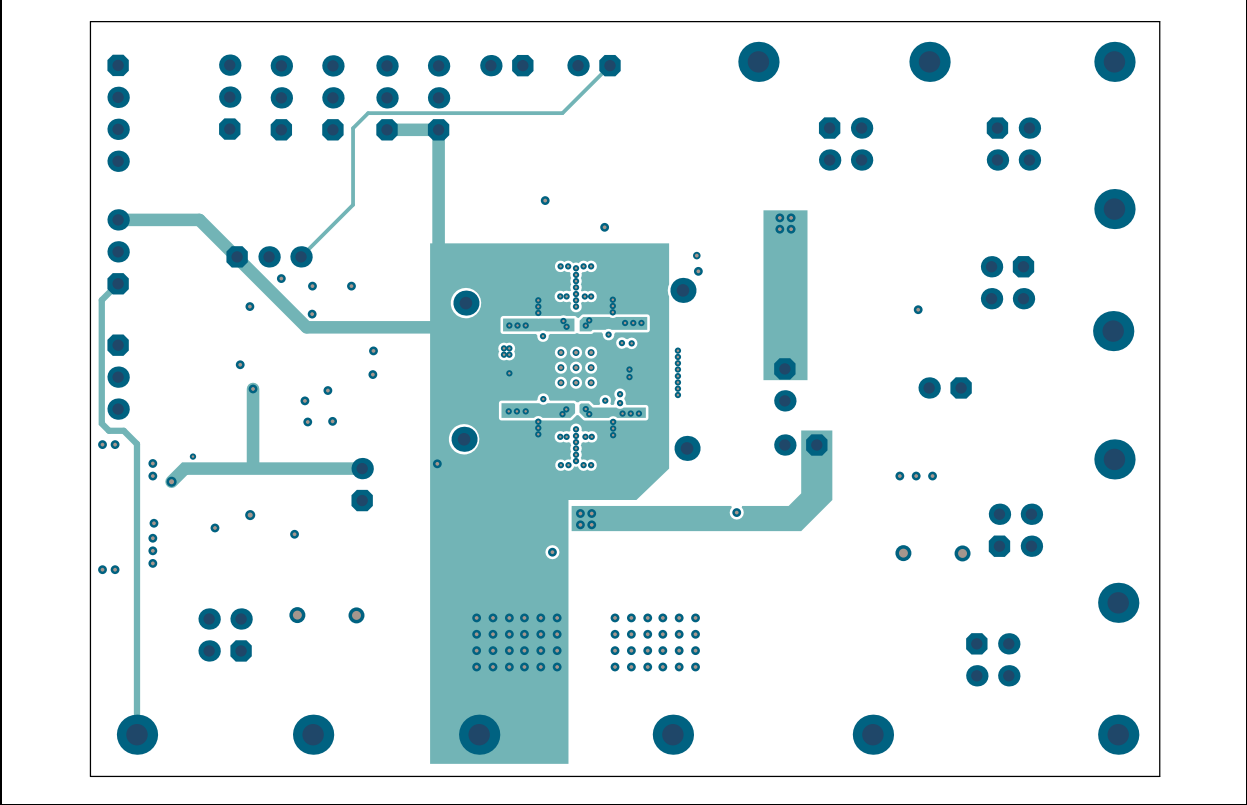

A.6 BOARD – BOTTOM COPPER AND SILK

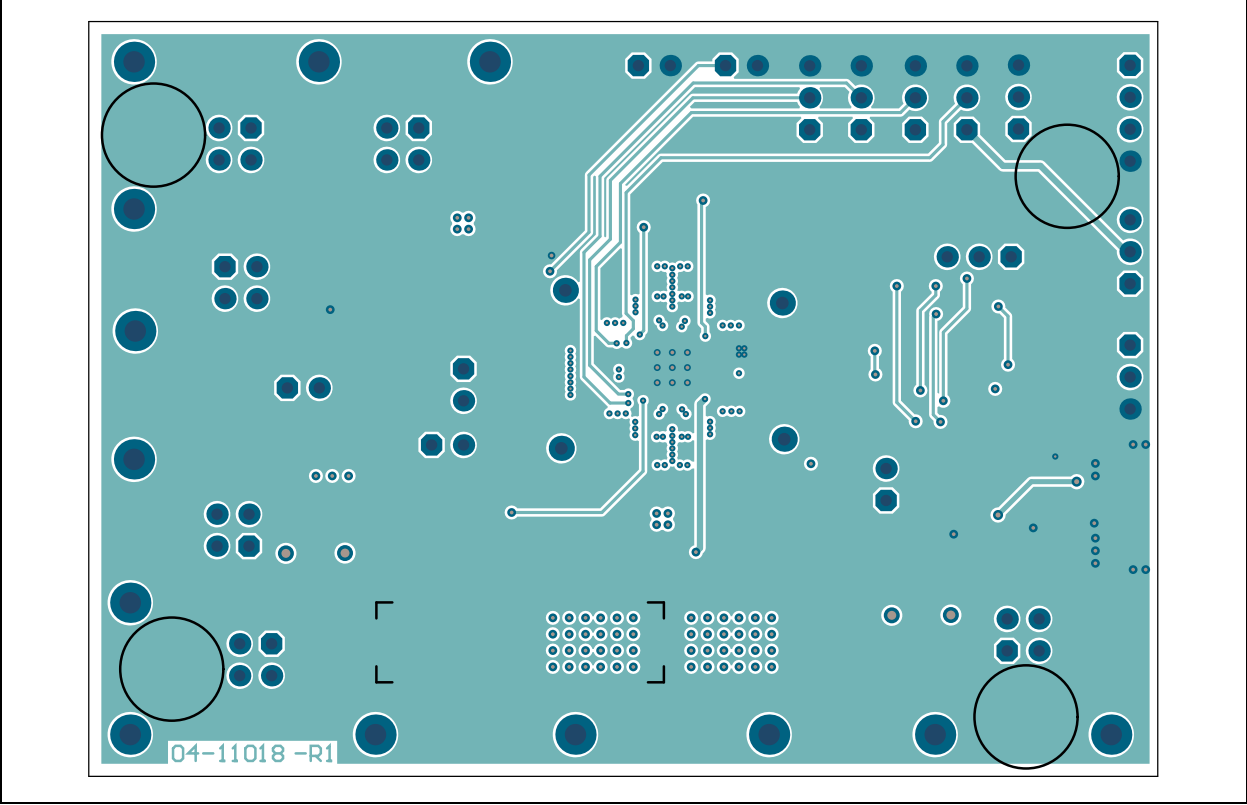

Appendix B. Bill of Materials (BOM)

TABLE B-1: BILL OF MATERIALS (BOM)

Qty.	Reference	Description	Manufacturer	Part Number
6	C1, C3, C7, C8, C9, C10	Ceramic, Capacitor, 4.7 μ F, 10V, 10%, X7S, SMD, 0603	TDK Corporation	C1608X7S1A475K080AC
4	C2, C4, C11, C12	Ceramic, Capacitor, 22 μ F, 10V, 20%, X7S, SMD, 0805	TDK Corporation	C2012X7S1A226M125AC
1	C5	Ceramic, Capacitor, 2.2 μ F, 10V, 10%, X7R, SMD, 0603	Taiyo Yuden Co., Ltd.	LMK107B7225KA-T
1	C6	Ceramic, Capacitor, 10 μ F, 10V, 10%, X7R, SMD, 0805	Samsung Electro-Mechanics America, Inc.	CL21B106KPQNFNE
1	C13	Ceramic, Capacitor, 0.1 μ F, 16V, 10%, X7R, SMD, 0603	Taiyo Yuden Co., Ltd.	EMK107B7104KA-T
1	C14	Ceramic, Capacitor, 0.47 μ F, 6.3V, 10%, X5R, SMD, 0603	Murata Electronics North America, Inc.	GRM188R60J474KA01D
1	C15	Aluminum, Capacitor, 330 μ F, 25V, 20%, SMD F	Nichicon Corporation	UWT1E331MNL1GS
1	D1	Diode, Rectifier, 1.25V, 150 mA, 75V, SOD-323	Diodes Incorporated [®]	1N4148WS-7-F
6	J1, J2, J32, J33, J34, J37	Connector, Header, 2.54 Male, 1x2, Gold, 5.84 MH, TH, Vertical	Amphenol Commercial	77311-118-02LF
8	J18, J22, J23, J25, J27, J31, J41, J42	Connector, Header, 2.54 Male, 1x3, Tin, 5.84 MH, TH, Vertical	Samtec, Inc.	TSW-103-07-T-S
1	J20	Connector, Header, 2.54 Male, 1x4, Gold, 5.84 MH, TH, Vertical	Würth Elektronik	61300411121
1	J30	Connector, USB, 2.0, Micro-B, Female, SMD, R/A	Amphenol Commercial	10118192-0001LF
4	L1, L2, L3, L4	Inductor, 1.5 μ H, 3.5A, 20%, SMD, 1008	Murata Electronics North America, Inc.	DFE252012P-1R5M=P2
1	PCB1	MCP16502 Evaluation Board – Printed Circuit Board	Microchip Technology Inc.	04-11018-R1
1	Q1	Transistor, MOSFET, N-Channel, 40V, 40A, 0.0028R, 71W, TDSO-8, AEC-Q101	Infineon Technologies AG	IPZ40N04S5L2R8ATMA1
5	R1, R3, R4, R17, R18	Resistor, TKF, 0R, SMD, 0402, AEC-Q200	Panasonic [®] - ECG	ERJ-2GE0R00X
1	R2	Resistor, TKF, 4.7R, 5%, 1W, SMD, 2512	Stackpole Electronics, Inc.	RPC2512JT4R70
1	R5	Resistor, TKF, 4.7R, 1%, 1/10W, SMD, 0805	Panasonic - ECG	ERJ-B3BF4R7V
1	R6	Resistor, TF, 100k, 1%, 1/8W, SMD, 0603	Vishay Beyschlag	MCT06030C1003FP500

Note 1: The components listed in this Bill of Materials are representative of the PCB assembly. The released BOM used in manufacturing uses all RoHS-compliant components.

MCP16502 Evaluation Board User's Guide

TABLE B-1: BILL OF MATERIALS (BOM) (CONTINUED)

Qty.	Reference	Description	Manufacturer	Part Number
2	R7, R22	Resistor, TF, 10k, 1%, 1/16W, SMD, 0603	TE Connectivity, Ltd.	CPF0603F10KC1
2	R9, R10	Resistor, TKF, 2.2k, 1%, 1/10W, SMD, 0603	Panasonic - ECG	ERJ3EKF2201V
3	R16, R19, R20	Resistor, TKF, 100R, 1%, 1/10W, SMD, 0402	Panasonic - ECG	ERJ2RKF1000X
1	R33	Resistor, TKF, 1k, 5%, 1/10W, SMD, 0603	Panasonic - ECG	ERJ3GEYJ102V
1	R34	Resistor, TKF, 20k, 5%, 1/10W, SMD, 0603	Panasonic - ECG	ERJ-3GEYJ203V
1	SW1	Tactile Switch, SPST, 12V, 50 mA, SMD	E-Switch [®] , Inc.	TL3301NF260QG
13	TP3, TP4, TP15, TP16, TP17, TP18, TP19, TP21, TP22, TP23, TP24, TP25, TP26	Connector, TP PIN, Tin, TH	Harwin Plc.	H2121-01
4	TP27, TP28, TP29, TP30	Miscellaneous, Test Point, Multi-Purpose, Miniature, White	Permabond [®]	5002
1	U1	Microchip Analog PMIC Switcher Buck ADJ, QFN-32	Microchip Technology Inc.	MCP16502AC-I/S8B
1	U2	Microchip Interface USB I ² C UART, TSSOP-14	Microchip Technology Inc.	MCP2221-I/ST

Note 1: The components listed in this Bill of Materials are representative of the PCB assembly. The released BOM used in manufacturing uses all RoHS-compliant components.

TABLE B-2: BILL OF MATERIALS (BOM) – MECHANICAL PARTS

Qty.	Reference	Description	Manufacturer	Part Number
6	JP1, JP2, JP3, JP4, JP5, JP6	Mechanical Headers and Wire Jumper, 2.54 mm, 1x2	3M	969102-0000-DA
4	PAD1, PAD2, PAD3, PAD4	Mechanical, HW, Rubber Pad, Cylindrical, D7.9, H5.3, black	3M	70006431483

Note 1: The components listed in this Bill of Materials are representative of the PCB assembly. The released BOM used in manufacturing uses all RoHS-compliant components.

TABLE B-3: BILL OF MATERIALS (BOM) – DO NOT POPULATE PARTS

Qty.	Reference	Description	Manufacturer	Part Number
1	C16	Ceramic, capacitor, 0.1 μF, 16V, 10%, X7R, SMD, 0603	Taiyo Yuden Co., Ltd.	EMK107B7104KA-T
1	C20	Ceramic capacitor, 10000 pF, 25V, 10%, X7R, SMD, 0603	Panasonic - ECG	ECJ-1VB1E103K
6	J16, J17, J21, J24, J28, J29	Connector, header, 2.54, male, 2x2, gold, 5.84 MH, TH, vertical	Würth Elektronik	61300421121

Note 1: The components listed in this Bill of Materials are representative of the PCB assembly. The released BOM used in manufacturing uses all RoHS-compliant components.



MICROCHIP

Worldwide Sales and Service

AMERICAS

Corporate Office
2355 West Chandler Blvd.
Chandler, AZ 85224-6199
Tel: 480-792-7200
Fax: 480-792-7277
Technical Support:
<http://www.microchip.com/support>
Web Address:
www.microchip.com

Atlanta

Duluth, GA
Tel: 678-957-9614
Fax: 678-957-1455

Austin, TX

Tel: 512-257-3370

Boston

Westborough, MA
Tel: 774-760-0087
Fax: 774-760-0088

Chicago

Itasca, IL
Tel: 630-285-0071
Fax: 630-285-0075

Dallas

Addison, TX
Tel: 972-818-7423
Fax: 972-818-2924

Detroit

Novi, MI
Tel: 248-848-4000

Houston, TX

Tel: 281-894-5983

Indianapolis

Noblesville, IN
Tel: 317-773-8323
Fax: 317-773-5453
Tel: 317-536-2380

Los Angeles

Mission Viejo, CA
Tel: 949-462-9523
Fax: 949-462-9608
Tel: 951-273-7800

Raleigh, NC

Tel: 919-844-7510

New York, NY

Tel: 631-435-6000

San Jose, CA

Tel: 408-735-9110
Tel: 408-436-4270

Canada - Toronto

Tel: 905-695-1980
Fax: 905-695-2078

ASIA/PACIFIC

Australia - Sydney
Tel: 61-2-9868-6733

China - Beijing
Tel: 86-10-8569-7000

China - Chengdu
Tel: 86-28-8665-5511

China - Chongqing
Tel: 86-23-8980-9588

China - Dongguan
Tel: 86-769-8702-9880

China - Guangzhou
Tel: 86-20-8755-8029

China - Hangzhou
Tel: 86-571-8792-8115

China - Hong Kong SAR
Tel: 852-2943-5100

China - Nanjing
Tel: 86-25-8473-2460

China - Qingdao
Tel: 86-532-8502-7355

China - Shanghai
Tel: 86-21-3326-8000

China - Shenyang
Tel: 86-24-2334-2829

China - Shenzhen
Tel: 86-755-8864-2200

China - Suzhou
Tel: 86-186-6233-1526

China - Wuhan
Tel: 86-27-5980-5300

China - Xian
Tel: 86-29-8833-7252

China - Xiamen
Tel: 86-592-2388138

China - Zhuhai
Tel: 86-756-3210040

ASIA/PACIFIC

India - Bangalore
Tel: 91-80-3090-4444

India - New Delhi
Tel: 91-11-4160-8631

India - Pune
Tel: 91-20-4121-0141

Japan - Osaka
Tel: 81-6-6152-7160

Japan - Tokyo
Tel: 81-3-6880-3770

Korea - Daegu
Tel: 82-53-744-4301

Korea - Seoul
Tel: 82-2-554-7200

Malaysia - Kuala Lumpur
Tel: 60-3-7651-7906

Malaysia - Penang
Tel: 60-4-227-8870

Philippines - Manila
Tel: 63-2-634-9065

Singapore
Tel: 65-6334-8870

Taiwan - Hsin Chu
Tel: 886-3-577-8366

Taiwan - Kaohsiung
Tel: 886-7-213-7830

Taiwan - Taipei
Tel: 886-2-2508-8600

Thailand - Bangkok
Tel: 66-2-694-1351

Vietnam - Ho Chi Minh
Tel: 84-28-5448-2100

EUROPE

Austria - Wels
Tel: 43-7242-2244-39
Fax: 43-7242-2244-393

Denmark - Copenhagen
Tel: 45-4485-5910
Fax: 45-4485-2829

Finland - Espoo
Tel: 358-9-4520-820

France - Paris
Tel: 33-1-69-53-63-20
Fax: 33-1-69-30-90-79

Germany - Garching
Tel: 49-8931-9700

Germany - Haan
Tel: 49-2129-3766400

Germany - Heilbronn
Tel: 49-7131-72400

Germany - Karlsruhe
Tel: 49-721-625370

Germany - Munich
Tel: 49-89-627-144-0
Fax: 49-89-627-144-44

Germany - Rosenheim
Tel: 49-8031-354-560

Israel - Ra'anana
Tel: 972-9-744-7705

Italy - Milan
Tel: 39-0331-742611
Fax: 39-0331-466781

Italy - Padova
Tel: 39-049-7625286

Netherlands - Drunen
Tel: 31-416-690399
Fax: 31-416-690340

Norway - Trondheim
Tel: 47-7288-4388

Poland - Warsaw
Tel: 48-22-3325737

Romania - Bucharest
Tel: 40-21-407-87-50

Spain - Madrid
Tel: 34-91-708-08-90
Fax: 34-91-708-08-91

Sweden - Gothenberg
Tel: 46-31-704-60-40

Sweden - Stockholm
Tel: 46-8-5090-4654

UK - Wokingham
Tel: 44-118-921-5800
Fax: 44-118-921-5820