

## Introduction (Ask a Question)

PCI Express (PCIe®) is a scalable, high-bandwidth serial interconnect technology that maintains compatibility with existing PCI systems. Microchip's PolarFire® Family of FPGAs contain fully integrated PCIe endpoint and root port subsystems with optimized embedded controller blocks that use the physical layer interface of the transceiver for the PCI Express (PIPE) interconnection within the transceiver block.

This user guide describes the PCIe subsystem available in the PolarFire family of devices. The FPGA fabric is common to the PolarFire family, which consists of the following FPGA devices.

- PolarFire FPGAs** Microchip's PolarFire® FPGAs are the fifth-generation family of non-volatile FPGA devices, built on state-of-the-art 28 nm non-volatile process technology. PolarFire FPGAs deliver the lowest power at mid-range densities. PolarFire FPGAs lower the cost of mid-range FPGAs by integrating the industry's lowest power FPGA fabric, lowest power 12.7 Gbps transceiver lane, built-in low power dual PCI Express Gen2 (EP/RP), and, on select data security (S) devices, an integrated low-power crypto co-processor.
- PolarFire SoC FPGAs** Microchip's PolarFire SoC FPGAs are the fifth-generation family of non-volatile SoC FPGA devices, built on state-of-the-art 28 nm non-volatile process technology. The PolarFire SoC family offers industry's first RISC-V based SoC FPGAs capable of running Linux®. It combines a powerful 64-bit 5x core RISC-V Microprocessor Subsystem (MSS), based on SiFive's U54-MC family, with the PolarFire FPGA fabric in a single device.
- RT PolarFire FPGAs** Microchip's RT PolarFire® FPGAs combine our 60 years of space flight heritage with the industry's lowest-power PolarFire FPGA family to enable new capabilities for space and mission-critical applications. RT PolarFire FPGA family includes RTPF500T, RTPF500TL, RTPF500TS, RTPF500TLS, RTPF500ZT, RTPF500ZTL, RTPF500ZTS, and RTPF500ZTLS devices.

Each device in the PolarFire family includes two embedded PCIe subsystem (PCIESS) blocks that can be configured using the PF\_PCIE configurator in the Libero® SoC software.

The following table summarizes the PCIESS components available in the PolarFire family.

**Table 1.** PCIESS Components

Fabric Component	PolarFire FPGA (MPF)	RT PolarFire FPGA (RTPF)	PolarFire SoC FPGA (MPFS)
Physical layer of XCVR	✓	✓	✓
PCIe IP (Data link layer (DL) and Transaction layer (TL))	✓	✓	✓
Bridge Layer	✓	✓	✓
AXI4 Layer	✓	✓	✓
<b>MSS Component</b>			
PCIe MSS	—	—	✓

The PCIESS supports AMBA AXI4 master/slave user interface functionality between the AXI4 and PCIe systems.

**Figure 1. PCIe Functional Layers of PCI ESS**

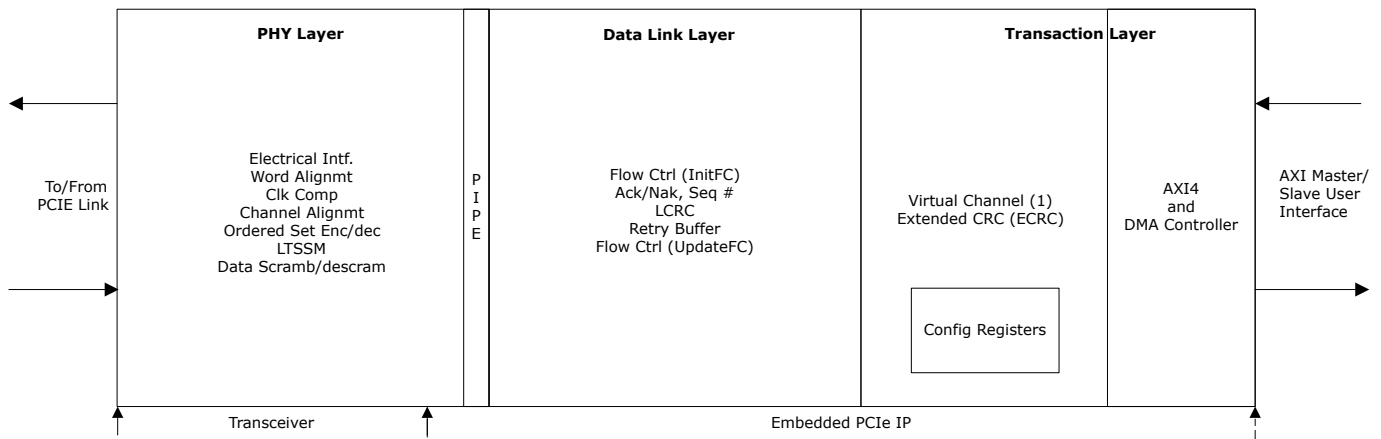

The PCI ESS is compliant with the following standards:

- [PCI Express Base Specification with GEN1/2, Revision 3.0](#)
- [PCI Express Card Electromechanical \(CEM\) 2.0](#)
- [PCI Industrial Computer Manufacturers Group \(PICMG\) 3.4](#)
- [PCI Power Management Specification, v1.2](#)
- [AMBA AXI Protocol Specification, Version 2.0 – ARM, March 2010](#)

## Features [\(Ask a Question\)](#)

The PCI ESS is a hard block and supports the following features:

- PCIe 3.0 compliant with 2.5 and 5.0 Gbps line speeds
- x1, x2, and x4 lane-support<sup>1</sup>
- Endpoint support for up to six 32-bit or three 64-bit base address register (BAR)
- Root port support for up to two 32-bit or one 64-bit BAR
- Two fully-independent Direct Memory Access (DMA) engines with Scatter-Gather DMA (SGDMA) support
- One virtual channel (VC)
- Single-function capability
- Maximum payload size (MPS) of up to 256 bytes
- Advanced error reporting (AER) support
- Integrated clock domain crossing (CDC) to support user-selected frequency
- Lane reversal/polarity inversion
- Legacy PCI power management
- Endpoint hot-plug capability (not supported for root port)
- Native active-state power management L0 and L1 support

<sup>1</sup> Each device supports two PCI ESS blocks, which shares four lanes within a transceiver block. This permits two x1 PCI ESS or two x2 PCI ESS that can run simultaneously, or one PCI ESS that can run as x4 and the other PCI ESS is left unused.

- Power management event (PME) message
- Latency tolerance reporting (LTR)
- 64-bit AXI master and slave interface to the FPGA fabric
- End-to-end data integrity

## References (Ask a Question)

- For information about transmitter, receiver, and transceiver block generation, see [PolarFire Family Transceiver User Guide](#).
- For information about DRI, see [PolarFire Family DRI User Guide](#).
- For information about PolarFire SoC PCIe Root Port Linux reference design, see [GitHub](#).
- For information about PolarFire FPGA reference design, see [PolarFire FPGA PCIe EndPoint DDR3L DDR4 Memory Controller Data Plane](#).
- For information about MSS, see [PolarFire SoC FPGA MSS Technical Reference Manual](#).
- For information about design initialization, see [PolarFire Family Device Power-Up and Resets User Guide](#).
- For information about board design recommendations, see respective [PolarFire FPGA Board Design User Guide](#) or [PolarFire SoC FPGA Board Design Guidelines User Guide](#).
- For information about configuration registers, see respective [PolarFire Device Register Map](#) or [PolarFire SoC Register Map](#).

# Table of Contents

Introduction.....	1
Features.....	2
References.....	3
1. Functional Descriptions.....	5
1.1. Physical Layer Interface.....	5
1.2. Data-link and Transaction Layers.....	8
1.3. Bridge Layer.....	11
1.4. AXI4 Layer.....	21
1.5. PCI ESS Configuration Interface.....	23
1.6. PCI ESS Port List.....	23
2. PCIe MSS.....	29
3. Implementation.....	33
3.1. Libero Configurators.....	34
3.2. PCIe Configurator.....	34
3.3. Design Constraints.....	44
3.4. PCIe Simulation.....	45
3.5. PCIe Subsystem Performance.....	47
3.6. Initialization.....	49
4. Configuration Registers.....	50
5. PCIe Configuration Space.....	52
6. Board Design Recommendations.....	54
6.1. AC-Coupling.....	54
6.2. Lane Reversal.....	54
6.3. Polarity Inversion.....	54
6.4. PCIe Power-Up.....	54
7. PCI-SIG TxPLL Electrical Compliance Test.....	56
8. Revision History.....	57
Microchip FPGA Support.....	60
Microchip Information.....	60
Trademarks.....	60
Legal Notice.....	60
Microchip Devices Code Protection Feature.....	61

# 1. Functional Descriptions [\(Ask a Question\)](#)

The PCIe subsystem uses several built-in features such as transceivers, embedded PCIe controller, and programmable FPGA resources. The functional details of the PCIe subsystem are described in this chapter.

As shown in the following figure, the PCI ESS is composed of four sub-modules:

- Physical layer
- PCIe DL and TL
- Bridge layer
- AXI layer
- Configuration interface (DRI and APB)

**Figure 1-1.** Embedded PCI ESS Architecture

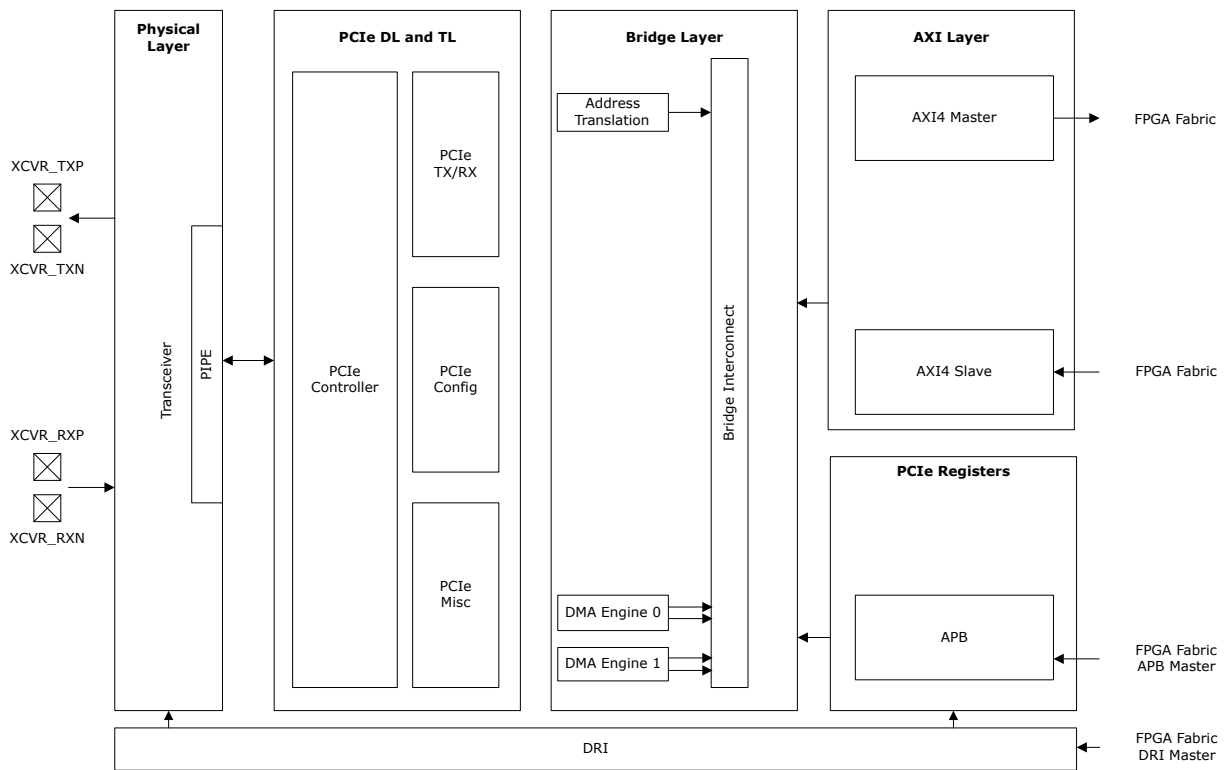

## 1.1. Physical Layer Interface [\(Ask a Question\)](#)

A PCIe lane consists of a pair of differential transmit signals and a pair of differential receive signals. The lanes are organized, as listed in the following table.

**Table 1-1.** Lane Configuration

X1	X2	X4
PCIe0 (Lane0) and PCIe1 (Lane2)	PCIe0 (Lane0, Lane1) and PCIe1 (Lane2, Lane3)	PCIe1 (Lane 0, Lane1, Lane2, and Lane3)

### 1.1.1. Physical Layer Functions [\(Ask a Question\)](#)

The physical layer is an electrical physical media attachment (PMA) required to connect to a PCIe system, and supports the following features:

- PCI Express 2.0 electrical compliance
- 2.5 and 5.0 Gbps common-mode logic (CML) electrical interface
- Signal integrity programmability including differential output voltage, transmitter de-emphasis, and receiver-side continuous-time linear equalization (CTLE)
- $\pm 300$  ppm clock-tolerance compensation
- Serializer and de-serializer
- 8b/10b symbol encoding/decoding
- Symbol alignment
- Framing and application of symbols to lanes
- Lane to lane Tx deskew

### 1.1.2. Receiver [\(Ask a Question\)](#)

The transceiver input includes all the features required to build a PCIe interface, such as input level sensitivity, signal detection, and termination. When PCISS is used within a device, the Libero SoC software configures the receiver with all the necessary input features. For more information, see [PolarFire Family Transceiver User Guide](#).

### 1.1.3. Transmitter [\(Ask a Question\)](#)

The transceiver output includes features such as output swing, termination, and de-emphasis. When PCISS is used within a device, the Libero SoC software configures the transmitter with all the necessary output features. For more information, see [PolarFire Family Transceiver User Guide](#).



**Important:** In PCIe subsystem, the receiver detection circuitry within the transmitter is bypassed and the link training and status state machine (LTSSM) state moves to “polling.compliance” state (when 50  $\Omega$  is terminated to the Transmitter) when REFCLK is available and TX PLL is locked. The link training remains unaffected when an active receiver is connected. This causes the optional key-sight protocol test card (PTC) test (LOOPBACK\_THROUGH\_CONFIG) to fail. To pass the test, set the PMA\_RXPLL\_FLOCK\_SEL bit to 0 when LTSSM is in “polling.compliance” state and set to 1 in other states.

### 1.1.4. Reference Clock [\(Ask a Question\)](#)

For PCIe applications, a differential 100 or 125 MHz reference clock with a  $\pm 300$  ppm tolerance is used by the transceiver transmit PLL and CDR PLL to generate the required 125 MHz output clock (depending on the lane speed settings), which is passed to the embedded PCISS. The settings for the transmit PLL and the CDR PLL are automatically determined by the Libero SoC software.

The transceiver reference clock inputs accept LVDS/CML/HCSL input clock signals according to PCIe specifications. Proper termination is included as required by the specification. For more information, see [PolarFire Family Transceiver User Guide](#).

According to PCIe specifications, upstream and downstream PCIe devices must transmit data at a rate within 600 ppm for each other at all times. This specification allows a reference clock with a  $\pm 300$  ppm tolerance. To ensure that the minimum clock period is not violated, the PCISS uses a spread-spectrum technique that does not permit modulation above the nominal frequency.

The data rate can be modulated from 0% to 0.5% of the nominal data rate frequency at a modulation rate ranging from 30 to 33 KHz. Along with the  $\pm 300$  ppm tolerance limit, both ports require the same bit-rate clock when the data is modulated using spread-spectrum clocking (SSC).

The PolarFire family of devices support the following clocking topologies defined by the PCIe specifications: common Refclk and separate Refclk.

- The Common Refclk is the most widely supported clocking method in open systems where the root port or root complex provides a clock to the endpoint. An advantage of this clocking architecture is that it supports SSC, which reduces electromagnetic interference (EMI).
- The Separate Refclk uses two independent clock sources: one each for the root and the endpoint. The clock sources must maintain  $\pm 300$  ppm frequency accuracy and cannot use SSC.

### 1.1.5. Low-Power States [\(Ask a Question\)](#)

The PCIExpress supports PCIe low-power operation states known as L0s and L1 states. These states are available in both, root port, and endpoint configurations.

**L0s** (Autonomous electrical idle): This state reduces power during short intervals of idle. Devices must transition to L0s independently on each direction of the link.

**L1** (Directed electrical idle): This state reduces power when the downstream port directs the upstream ports. This state saves power in two ways:

- Shutting down the transceiver circuitry and associated PLL.
- Significantly decreasing the number of internal core transitions.



**Important:** PCIe Link Training and Status State Machine (LTSSM) hardware blocks of PolarFire transceiver do not support the L2/P2 power management link state. The L2/P2 power management link state does not achieve further operational power-savings for the PolarFire device.

To achieve further operational power savings, on top of the already power-optimized PolarFire device architecture, the FPGA designer must employ power management techniques directly to the FPGA fabric design.

- Software-driven L2/P2 entry commands issued by the PolarFire PCIExpress Root Port to the downstream endpoints are not supported to the down-stream end-points. As a Root Port, this causes the link to be completely disrupted and only recoverable by re-initializing the link with side-band PERSTn (fundamental reset) or a power cycle.
- PolarFire PCIExpress endpoint must not be commanded by the host to enter L2/P2 link state. As an endpoint, the link might be disruptive and only recoverable by re-initializing the link with side-band PERSTn (fundamental reset) or a power cycle.

 **Important:** The following are the debug recommendations when LTSSM does not reach L0.

- Power OFF the host PC while inserting the PCIe Edge connector. If it is not powered OFF, the PCIe device detection and the selection of Gen1 or Gen2 mode may fail. The device detection and selection depend on the host PC PCIe configuration. When the host PC is powered ON, check if the PCIe is detected in the device manager of the host PC. For more information about Board to the host PC PCIe slot connection, see [PolarFire FPGA PCIe EndPoint DDR3L DDR4 Memory Controller Data Plane](#).
- Using SmartDebug, you can check LTSSM state status. For more information, see [SmartDebug User Guide](#).
- A third-party logic analyzer for PCI Express records the traffic on the physical link and decodes traffic. A third party logic analyzer can show the two way traffic at different levels for different requirements. For high-level diagnostics, the analyzer shows the LTSSM flows for devices on both side of the link side-by-side. This display can help you see the link training handshake behavior and identify where the traffic is stuck. You can also verify the contents of packets displayed on traffic analyzer.

## 1.2. Data-link and Transaction Layers [\(Ask a Question\)](#)

The PCIe DL and TL includes:

- PCIe controller
  - Lane reversal
  - Link training and status state machine (LTSSM)
  - Electrical idle generation
  - Receiver detection
  - TS1/TS2 generation/detection
- PCIe transmit/receive interface between the PCIe bridge and PCIe controller
- PCIe configuration interface providing the bridge access to the PCIe configuration space
- PCIe miscellaneous interface to allow the bridge access to manage low-power and interrupts

The PCIe includes the data path from the transceiver to the user-defined application layer of the FPGA fabric. The AXI4 bridges the application layer to the transaction layer. The transaction layer communicates with the data-link layer through FIFOs. The data-link layer communicates with the physical layer through FIFOs. The data is then passed to the transaction layer blocks that manage read and write requests from the software. Finally, the data is passed to the application layer hosted in the FPGA fabric ([Figure 1-7](#)).

**Data Link Layer** – The data link layer (DL) is responsible for link management including transaction layer packet (TLP) acknowledgment (a retry mechanism in case of a non-acknowledged packet), flow control across the link (transmission and reception), power management, CRC generation and checking, error reporting, and logging. The DL verifies the packets sequence number and checks for errors. The DL ensures packet integrity, and adds a sequence number and Link Cyclic Redundancy Check (LCRC) to the packet.

The replay buffer located in the data link layer stores a copy of a transmitted TLP until the transmitted packet is acknowledged by the receive side of the link. Each stored TLP includes the header, an optional data payload (the maximum size of which is determined by the maximum payload size parameter), an optional end-to-end cyclic redundancy check (ECRC), the sequence number, and the link cyclic redundancy check (LCRC) field for transaction and data integrity. The

replay buffer stores the read data payload from the AXI4 master and write data payload from the AXI4 slave.

**Transaction Layer** – The transaction layer is responsible for the transfer of transaction layer packets (TLP). The transaction layer disassembles the transaction and transfers data to the application layer in a form that it can recognize. The transaction layer generates a TLP from information sent by the application layer. This TLP includes a header and can also include a data payload. The application communicates to the PCIe link using AXI4 master and slave interface through bridge layer.

### 1.2.1. Flow Control [\(Ask a Question\)](#)

PCIe is a flow control-based protocol. Receivers advertise the supported number of receive buffers, and transmitters are not allowed to send TLPs without ensuring that sufficient receive buffer space is available. This control is provided by the 8 KB dedicated buffers included in the PCI ESS receive and transmit channels.

**Maximum Payload Size** – The size of the TLP depends on the capabilities of both link partners. After the link is trained, the root complex sets the maximum payload size register (MAX\_PAYLOAD\_SIZE) value in the device control register. The maximum allowable payload size is 256 bytes.

### 1.2.2. Credit Queue [\(Ask a Question\)](#)

PCIe credit queues are categorized into posted, non-posted, and completion queues. When the host sends writes to the PCI ESS, this data consumes posted and non-posted credits. When the host needs to send a completion to a read, it consumes completion credits. As is the case for most PCIe endpoints, the completion credit count is infinite in the PCI ESS.

A completion timeout is a condition where the host blocks completion due to the lack of non-posted credits. When the PCI ESS does a read, if completion data is not returned, the PCI ESS issues a completion timeout and the transaction is voided, triggering the AXI slave to terminate the read to avoid a deadlock.

All credit settings are automatically set according to the buffer sizes fixed in the PCI ESS. As per PCIe standards, when the PCIe controller issues a read request, it ensures that the controller can sync with the associated read data (completion TLP).

### 1.2.3. Receive Buffer [\(Ask a Question\)](#)

The transaction layer contains an 8-KB receive buffer to accept incoming TLPs from the link and send them to the application layer for processing. The receive buffer stores TLPs based on the transaction type (posted, non-posted, or completion). A transaction always has a header but does not always have data. The receive buffer accounts for this distinction, maintaining separate resources for the headers and data for each type of transaction. For completion transactions, data (CPLD) TLPs are stored in the received buffer in the 64-bit addressing format, with each outstanding AXI4 slave read request consuming 16 credits (totaling 128 bytes), and the headers and data consuming one credit each (totaling 16 bytes).

### 1.2.4. Replay Buffer [\(Ask a Question\)](#)

In the transmit direction, the AXI4 bridge layer first checks the credits available on the far end before sending the TLP. There must be enough credits available for the entire TLP to be sent. The AXI4 bridge layer must then check that the PCI ESS is ready to send the TLP. If there is enough credit, it can proceed with sending data. If the credit is insufficient, the TLP must wait until enough credit is available.

The replay buffer is used to fetch TLPs that are:

- Issued by the AXI before their transmission on the PCIe link.
- Transmitted on the PCIe link, as long as they are not acknowledged by the opposite PCIe device, in case a replay is required.

The replay buffer is 8 KB, allowing the transmit buffer to support up to 16 outstanding transmit replay data packets with a maximum payload of 256 bytes each. A maximum of 32 TLPs can be supported by the replay buffer.

## Compliance

PCIe Protocol Compliance Test with LeCroy Exerciser:

Device testing for PCIe compliance with a LeCroy exerciser reports a failure for a PTC test related to Replay Buffer. However, the PTC test conducted on the Key-sight exerciser passed successfully. PolarFire FPGA met full compliance at the PCISIG Compliance Workshop #101 and entered into the integrators list. PTC Test 52-20 (LinkRetrainOnRetryFail) fails in the LeCroy testing suite. The root-cause is that the PCIe controller executes some of the second-round replays; prior to, rather than after, link re-training. It does not impact any application functionality as no transaction layer packet (TLP) is lost due to the built-in replay mechanism required by the PCIe base specification. Replays occur both before and after link re-training as long as TLP is not acknowledged.

### 1.2.5. Extended CRC [\(Ask a Question\)](#)

The PCI ESS optionally performs automatic ECRC to ensure data integrity by default is disabled. The PCIE\_PEX\_SPC2 bridge configuration register controls the ECRC settings. For information about Configuration registers, see respective [PolarFire Device Register Map](#) or [PolarFire SoC Register Map](#).

ECRC is enabled when PCIE Specific Capabilities Settings Register PCIE\_PEX\_SPC Bit[31] is set to 1 to indicate Advanced Error Reporting (AER) is enabled. ECRC error generation and checking can further be individually disabled or enabled by PCIE\_PEX\_SPC2 Bit[1] and Bit[2] register .

### 1.2.6. ECC [\(Ask a Question\)](#)

PCIe subsystem has—AXI to PCIE, PCIE to AXI, Rx, Tx—memory buffers as shown in the following figure. These buffers support ECC capability with single bit error correction. ECC can be disabled or enabled by configuring the ECC\_CONTROL register.

**Figure 1-2.** PCIe Subsystem Memory Buffers

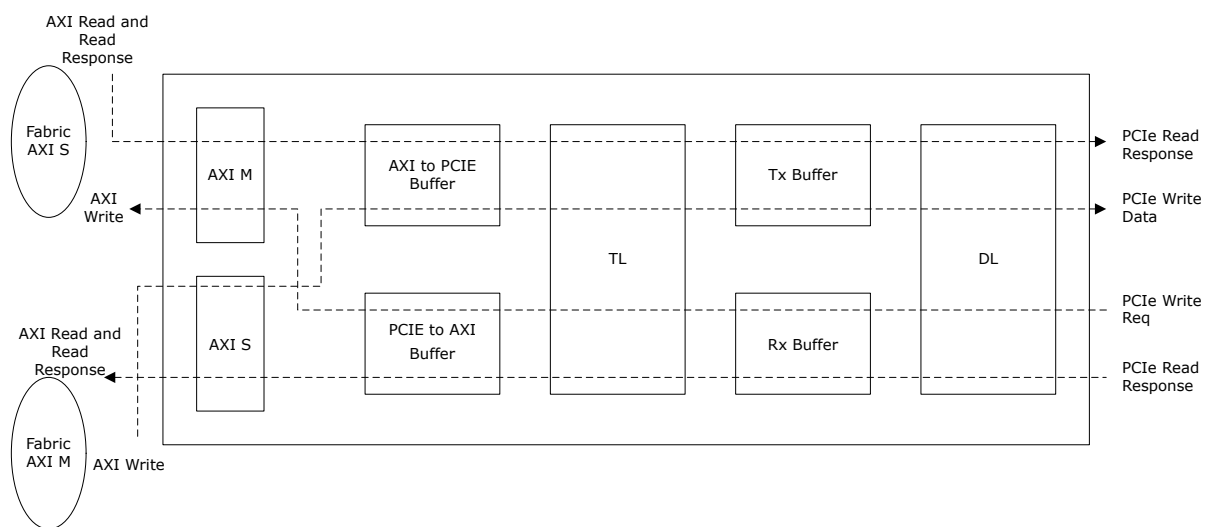

### 1.3. Bridge Layer [\(Ask a Question\)](#)

The bridge layer includes:

- Two independent DMA engines.
- An address translator to convert between the AXI and PCIe interfaces.
- A bridge interconnect module to interconnect and arbitrate between input and output flows.

#### 1.3.1. DMA Transfers [\(Ask a Question\)](#)

Each PCIe controller supports the following built-in DMA features, enabling low-power and efficient data transfer to the FPGA fabric:

- Eight outstanding read and write requests
- Completion re-ordering support
- Flexible SGDMA modes, including dynamic DMA control per descriptor
- DMA engine that reports to the descriptor for easy software management
- Fetches up to three descriptors to optimize throughput

The PCISS has two fully-independent DMA engines (DMA0 and DMA1), which helps to deliver higher performance on both, write and read functions. Each DMA engine can be configured to function as direct DMA or SGDMA. The DMA engines can be configured using PCISS registers. For more information about DMA registers, see respective [PolarFire Device Register Map](#) or [PolarFire SoC Register Map](#).

In direct DMA transfer mode, the DMA start address is a pointer to a contiguous data buffer mapped in the PCI bus address space. Data is read from and written to the buffer sequentially.

For DMA0, source is fixed to PCIe IF and destination is configurable. DMA0 is used to transfer data from:

- PCIe link (Host PC memory) to EP AXI (LSRAM/DDR in EP design).
- PCIe link (Host PC memory) to PCIe link (Host PC memory).

For DMA1, source is fixed to AXI IF and destination is fixed to PCIe IF. DMA1 is used to transfer data from EP AXI (LSRAM/DDR in EP design) to PCIe link (Host PC memory).

**Figure 1-3.** Direct DMA Transfer

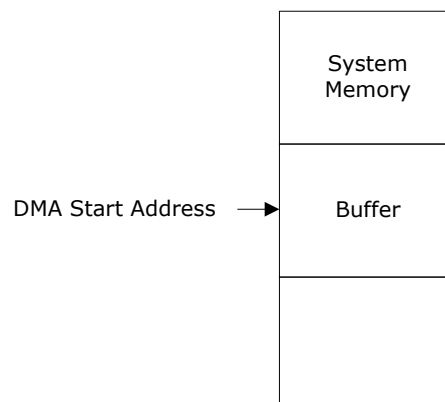

In SG transfer mode, the DMA source and/or destination start address is a pointer to a chained list of page descriptors. Each descriptor contains the address and size of a data block (page), and a pointer to the next descriptor block to enable circular buffers.

Figure 1-4. SGDMA Transfer

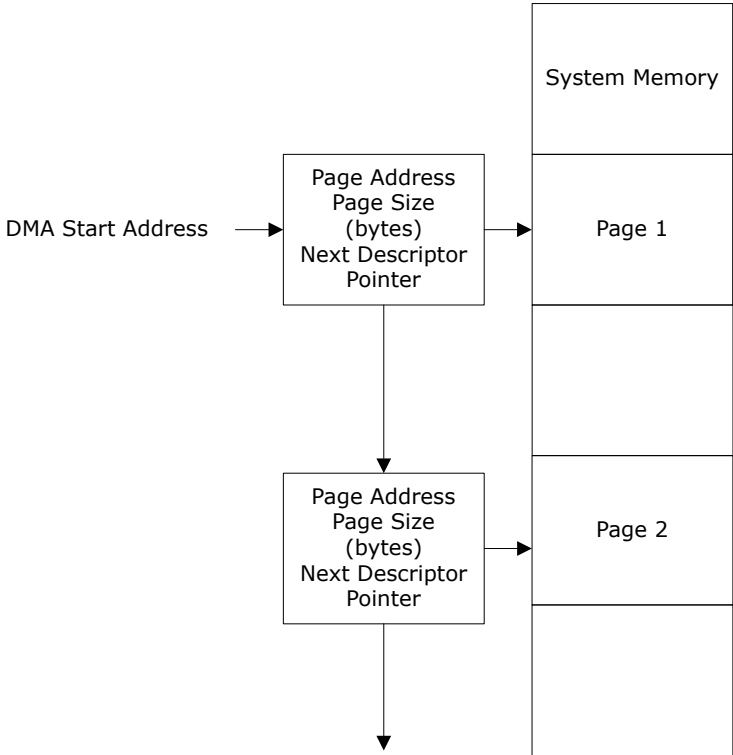

The implementation of SGDMA transfer is different in DMA0 and DMA1.

**SGDMA Transfer in DMA0**

Source and Destination addresses are set according to the Descriptor. DMA source is always PCIe link and destination can be configured as PCIe link or AXI Master.

Figure 1-5. DMA0 Descriptor

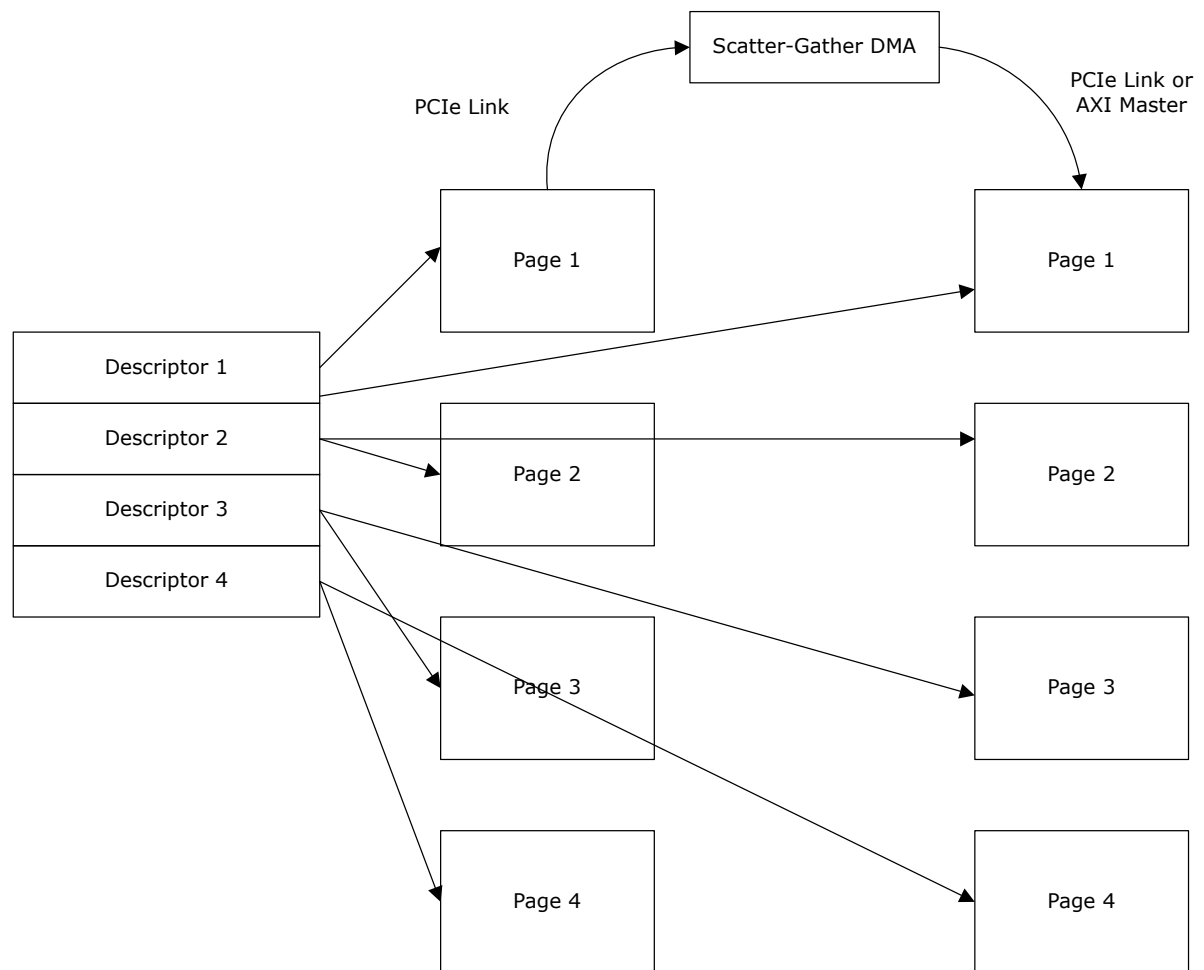

**Note:** For DMA0, addresses and length must be multiples of 4 bytes. Source and destination start addresses must be 32 byte aligned. For example, if the start address is 0xXX14 and the destination address can be 0xXX14, 0xXX34, 0xXX54 and so on.

### SGDMA Transfer in DMA1

Source and destination addresses are set by two independent Scatter-Gather descriptors all DMA destination is always PCIe and source is AXI IF.

Figure 1-6. DMA1 Descriptor

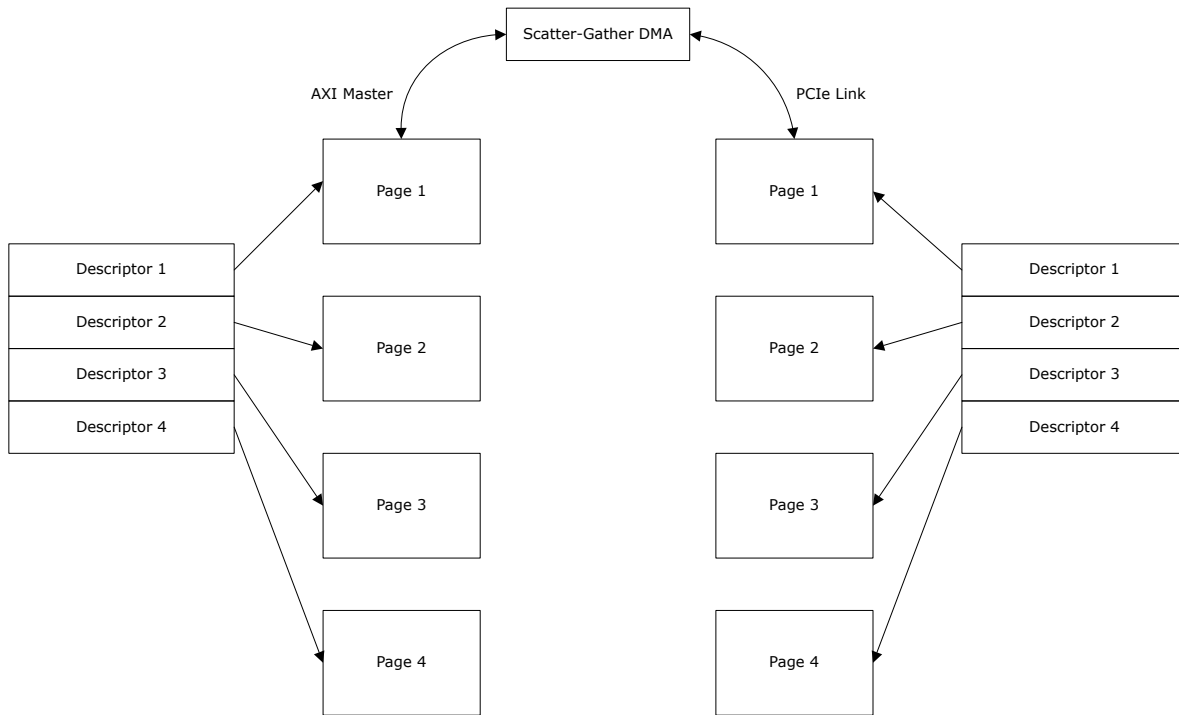

**Note:** For DMA1, addresses and length must be multiple of 32 bytes. Source and destination start addresses must be 32 byte aligned.

1.3.2. Scatter-Gather DMA Descriptors [\(Ask a Question\)](#)

The following table lists the Scatter-Gather DMA Descriptors.

Table 1-2. Scatter-Gather DMA Descriptors

Name	Byte Offset	R/W	Description
DESC_STATUS	0x00 - 0x03	RW	Enables dynamic monitoring of the SGDMA transfer (when 0 <sup>th</sup> bit of DESC_CONTROL register is set) Bits [3:0]: Provides the status number of the DMA engine. This number is incremented, enabling the application to determine the last processed descriptor, which is key in streaming flow between asynchronous devices. Bits [7:4]: Bit 4: Indicates SG-DMA descriptor has been processed. Bit 5: Indicates an error occurred during the processing of the current SGDMA descriptor. Bit 6: Indicates an End of Packet (EOP) condition has been reported by the source of the SGDMA transfer. Bit 7: Reserved Bits [31:8]: Indicates the Processed Page Size, which is the actual written or read page size.

**Table 1-2. Scatter-Gather DMA Descriptors (continued)**

Name	Byte Offset	R/W	Description
DESC_CONTROL	0x04 - 0x07	RO	DESC_CONTROL enables dynamic control of the SGDMA transfer. Bit [0]: Defines whether the DMA engine provides a status report by writing to DESC_STATUS when the current SGDMA descriptor has been processed. Bits [3:1]: Reserved Bits [7:4]: Defines when an interrupt must be issued. Bit 4: Indicates an IRQ is issued when this SGDMA descriptor has been processed. Bit 5: Indicates an IRQ is issued if an error occurs. Bit 6: Indicates an IRQ is issued if the source of the transfer reports an EOP condition. Bit 7: Reserved Bits [31:8]: Provides the page size in bytes, from 1 to 16 M bytes.
DESC_NEXT_ADDR[63:32]	0x0C - 0x0F	RO	Indicates next descriptor address. This field must be aligned on a 32-byte boundary.
DESC_NEXT_ADDR[31:5]	0x08 - 0x0B	RO	Indicates next descriptor address.
DESC_NEXT_RDY[4]			Indicates if the next SGDMA Descriptor is ready and fetch-able.
DESC_SE_COND[3:0]			Defines the Start and End conditions for SGDMA descriptor processing. Bit 0: Indicates end the DMA transfer after this SGDMA descriptor has been processed (equivalent to an End Of Chain). Bit 1: Indicates to abort this SGDMA descriptor processing if an error occurs. Bit 2: Reserved Bit 3: Indicates to start this SGDMA descriptor processing when the source of the transfer reports a SOP reception.
DESC_SRC_ADDR[31:0]			Indicates the source address of the descriptors. It must be 32 byte aligned.
DESC_SRC_ADDR[63:32]	0x14 - 0x17	RO	
DESC_DEST_ADDR[31:0]	0x18 - 0x1B	RO	Indicates the destination address of the descriptors. It must be 32 byte aligned.
DESC_DEST_ADDR[63:32]	0x1C - 0x1F	RO	

### 1.3.3. PCIe/AXI4 Address Translation [\(Ask a Question\)](#)

There are six address table registers (ATRs) that perform address translation from the PCIe address space (BAR) to the AXI master, and six ATRs for the slave, which addresses translation from the AXI4 slave to the PCIe address space.

For the address translation, PCIESS uses the following:

- Master Windows
- Slave Windows

#### 1.3.3.1. Master Windows [\(Ask a Question\)](#)

Master windows translate the addresses from PCIE domain to AXI 4 domain.

When the PCIESS is in endpoint mode, there is direct mapping between the BAR and the address tables, as shown in the following figures.

Each 32-bit BAR has an address translation table (ATR). The PCIe implementation supports up to six 32-bit base address registers (BARs). Each BAR is 32 bits, but two BARs can be combined to make a 64-bit BAR. For example, BAR0 (address offset 010h) and BAR1 (address offset 014h) can be combined to form a 64-bit BAR01.

For a 64-bit BAR mapping, address tables are used as follows:

- BAR01 targets ATR0, and ATR1 remains unused
- BAR23 targets ATR2, and ATR3 remains unused
- BAR45 targets ATR4, and ATR5 remains unused

**Figure 1-7.** PCIe to AXI4 Master Address Translation Endpoint Mode for 32-Bit BAR

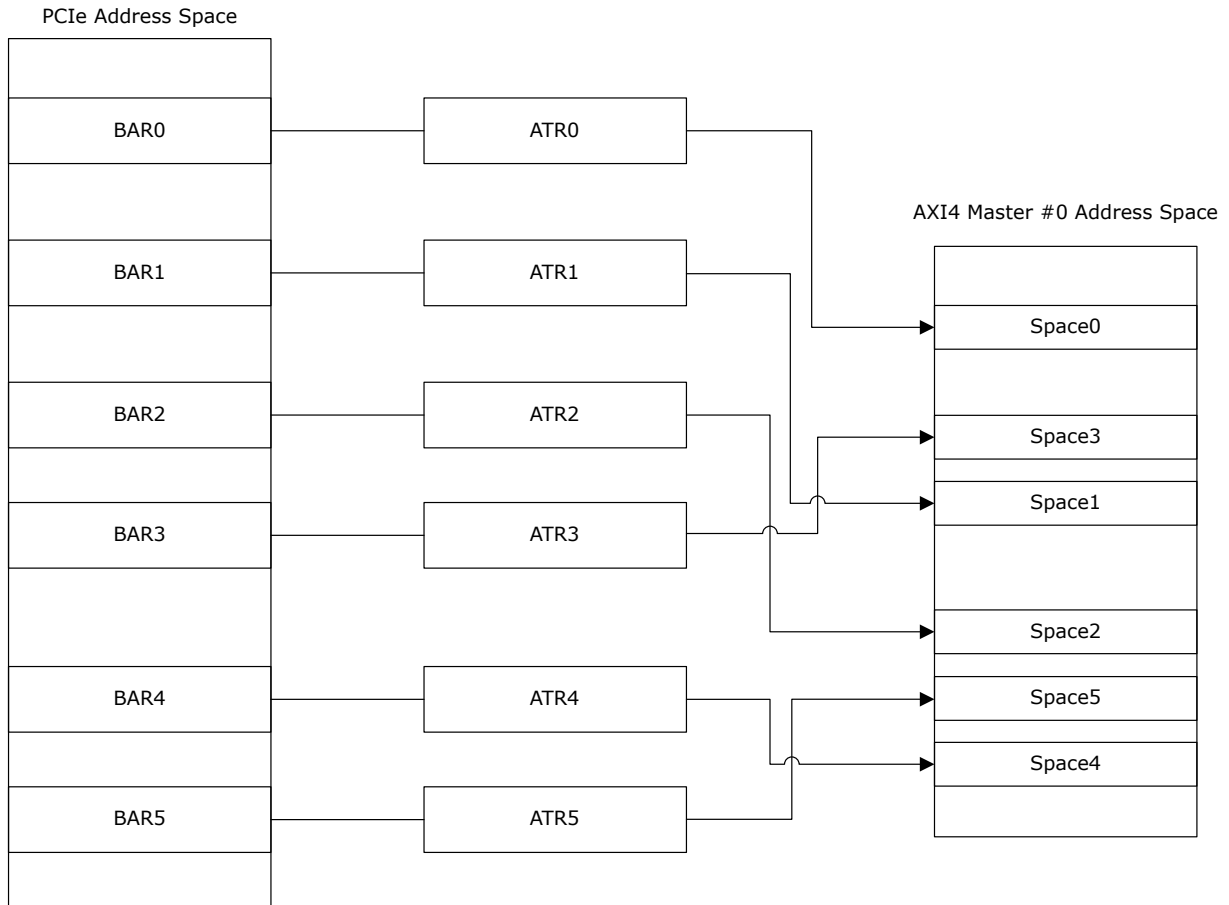

**Figure 1-8.** PCIe to AXI4 Master Address Translation Endpoint Mode for 64-Bit BAR

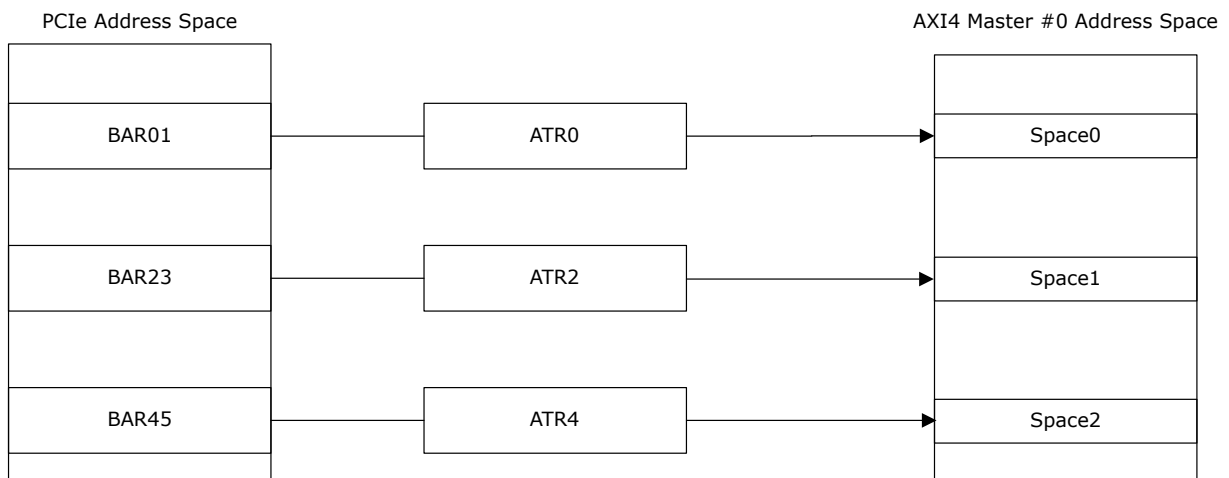

The PCI Express Configurator in Libero SoC software provides a GUI to configure the BAR settings for an endpoint application.

The following figure shows an example of configuring Master settings to map the BAR0 transactions to PCIe AXI master IF transactions for AXI address 0xBB000000.

**Figure 1-9.** Example of Configuring Master EP Settings

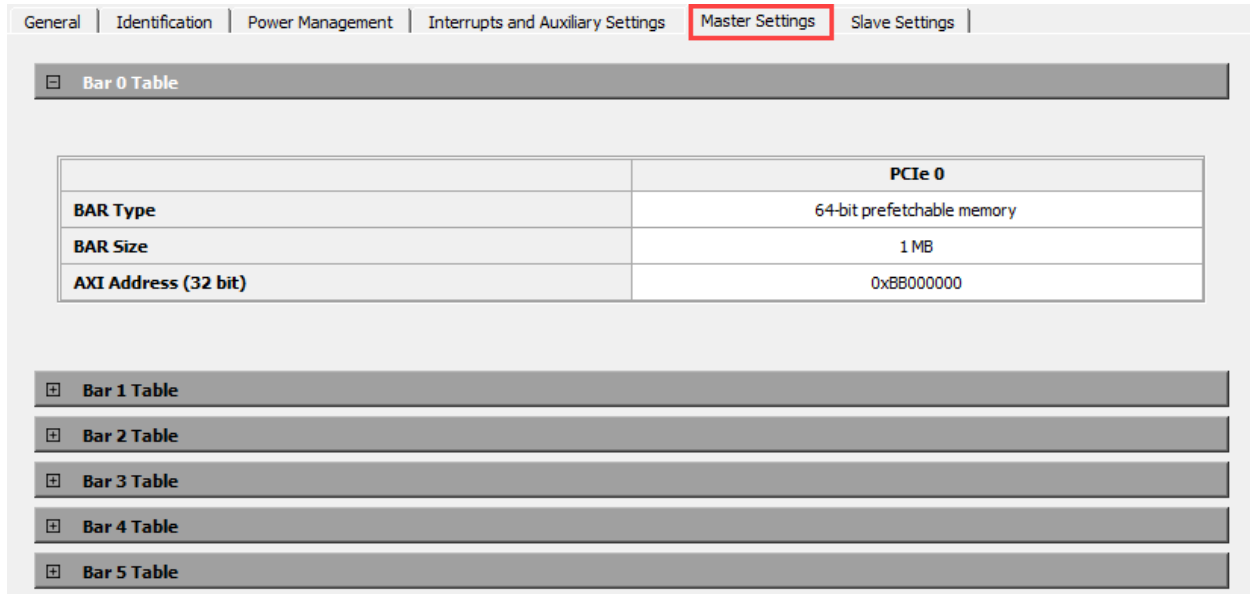

If BAR0 receives write/read request with offset 1010, then ATR0 translates this address to 0xBB001010.

**Figure 1-10.** PCIe to AXI4 Master Address Translation Endpoint Mode Example

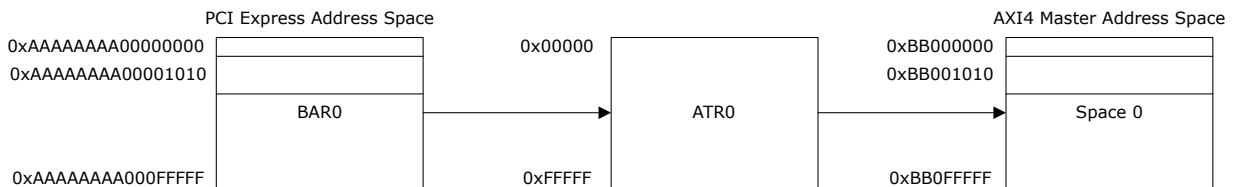

**Note:** In this example, BAR0 address of host is shown as 0xAAAAAAAA00000000.

When the PCI Express is in root port mode (Figure 1-11), up to six translation tables (currently, Libero SoC supports two translation tables) can be implemented. When transferring PCI Express receive requests to the AXI master, the bridge performs a windows match using the PCIe 64-bit address. If a match is found, the bridge forwards the request to the desired AXI4 master interface and adds the corresponding AXI base address.

When the PCI Express BAR0/1 are configured as a 64-bit prefetchable memory space of 16 Kbytes, PCIe read and write requests targeting BAR0 or BAR1 are routed to the bridge configuration space. This memory space operates in the following two ways:

- When I/O or prefetchable memory windows are implemented, PCIe read and write requests targeting I/O or prefetchable memory windows are routed to the PCIe window address translation module.
- When I/O or prefetchable memory windows are not implemented, PCIe read and write requests that do not target BAR0 or BAR1 are routed to the PCIe window address translation module.

Figure 1-11. PCIe to AXI4 Master Address Translation Root Port Mode

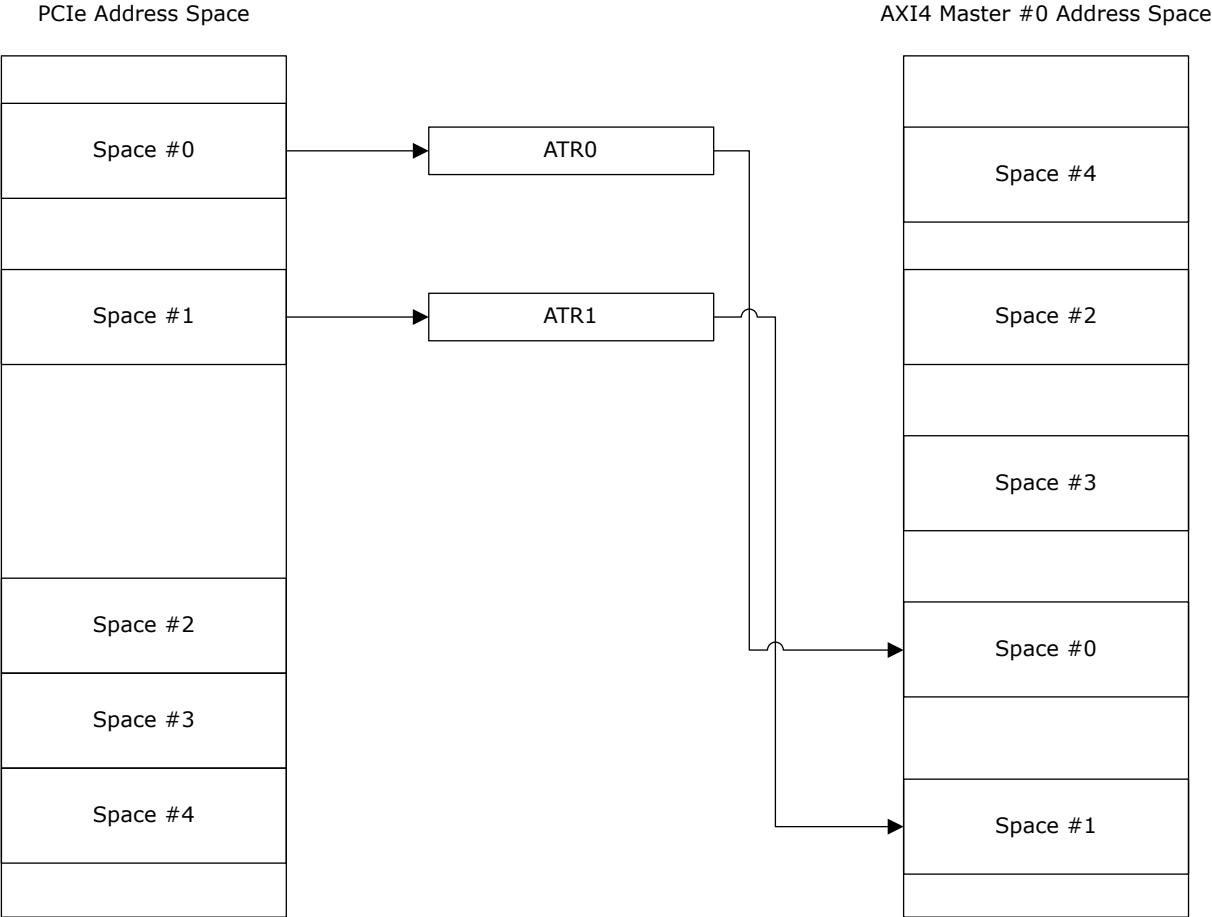

The following figure shows an example of configuring Master settings to map the PCIe RP address space to PCIe AXI master IF address space for AXI address 0xBB000000.

**Figure 1-12.** Example of Configuring Master RP Settings

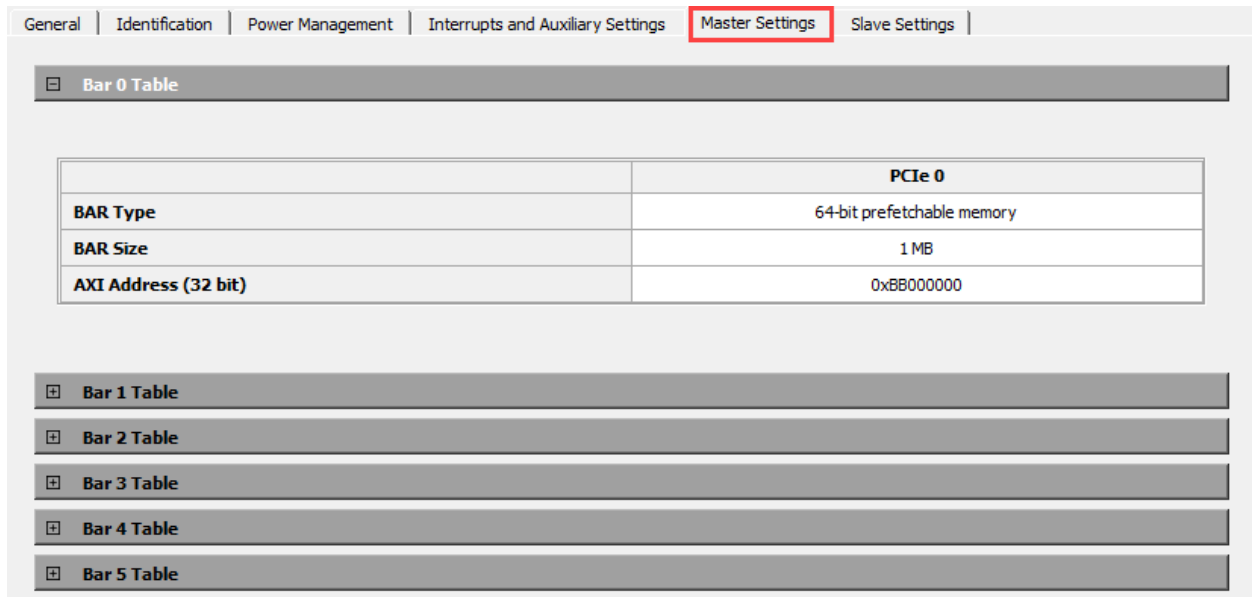

When PCIe receives write/read request at address 0x00001010, this address is mapped to ATR0, which removes the upper 44 bits (depending on table size) and adds the translation address 0xBB000000 to offset 0x1010.

**Figure 1-13.** PCIe to AXI4 Master Address Translation Root Port Mode Example

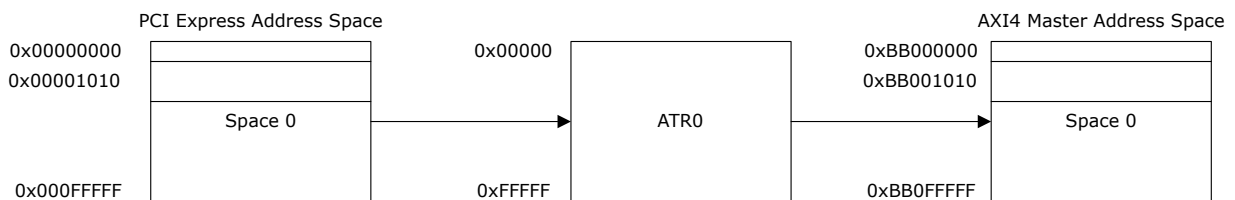

**1.3.3.2. Slave Windows** [\(Ask a Question\)](#)

The address translation method used to transfer AXI slave receive requests to the PCIe interface is similar to the method used in the endpoint mode. Up to six translation tables can be implemented for AXI4 slave interface.

**Figure 1-14.** AXI4 Slave to PCIe Address Translation

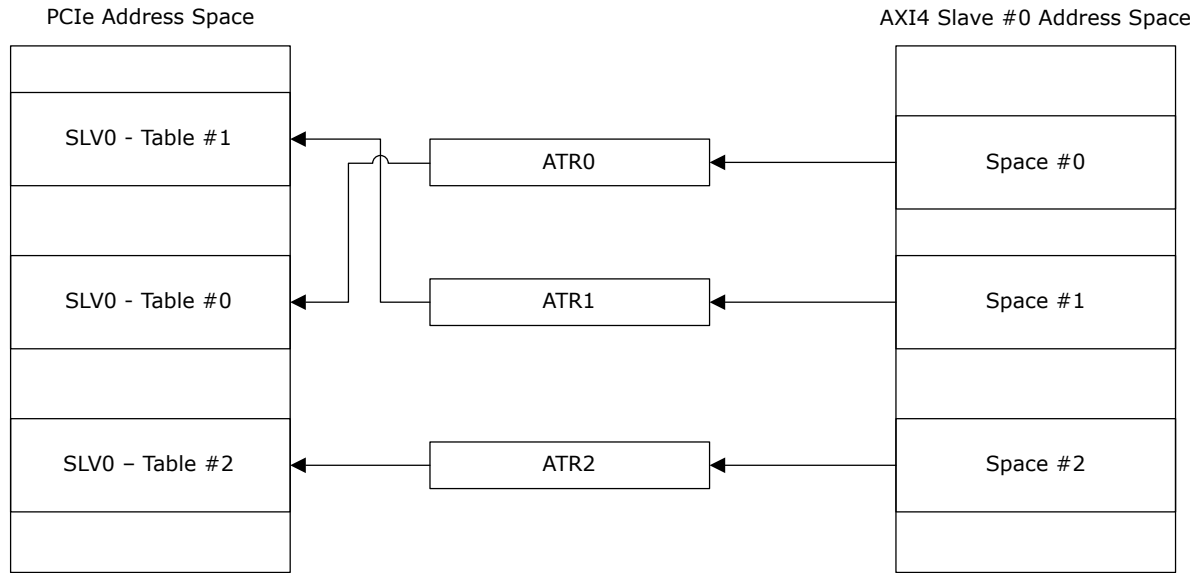

The following figure shows an example of configuring Slave settings to map AXI IF slave requests to PCIe requests for AXI address 0xBB000000 and PCIe address 0xAAAAAAAA00000000.

**Figure 1-15.** Example of Slave EP Settings

General | Identification | Power Management | Interrupts and Auxiliary Settings | Master Settings | **Slave Settings**

Slave 0 Table

PCIe 0	
State	Enabled
Size	1 MB
AXI Address (32 bit)	0xBB000000
Translation Address (64 bit)	0xAAAAAAAA00000000

Slave 1 Table

Slave 2 Table

Slave 3 Table

Slave 4 Table

Slave 5 Table

When PCIe receives write/read request at address 0xBB001010, this address is mapped to Table0, which removes the upper 12 bits (depending on table size) and adds the translation address 0xAAAAAAAA00000000 to offset 0x1010.

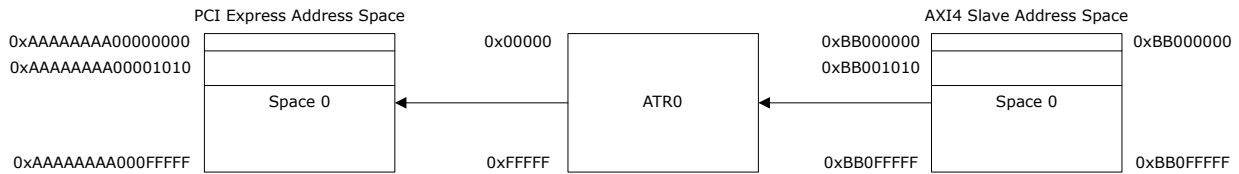
**Figure 1-16.** AXI4 Slave to PCIe Address Translation Example

## 1.4. AXI4 Layer [\(Ask a Question\)](#)

The AXI4 layer of the PCI ESS provides a transaction-level translation of AXI4 commands to PCIe packets and PCIe requests to AXI4 commands. The user application in the FPGA fabric must implement an AXI4 master interface to transfer data to the PCIe link and an AXI4 slave interface to receive data from the PCIe link.

### 1.4.1. AXI MasterIF [\(Ask a Question\)](#)

A typical PCIe application interface uses an AXI master interface to respond to data read requests and an AXI slave interface to initiate requests. The AXI master performs the following functions:

- Conveys PCIe read and write transactions to the fabric in the form of AXI4 reads and writes.
- Accesses the DMA controller through the bridge and issues reads and writes that allow data pulled from the fabric to be sent over PCIe and data pulled from the PCIe to be written out to the fabric.

#### 1.4.1.1. AXI Master Write Transactions [\(Ask a Question\)](#)

Write transactions are handled in big-endian order as required by the PCI Express Base Specification. The master path does not reorder transactions, but arbitrates between transactions at the AXI4 master interface. If a transaction is currently waiting for a response phase, the transaction is allowed to complete before the read transaction is forwarded to the AXI4 master interface. The maximum number of outstanding write transactions supported in non-DMA mode is eight. PCIe transactions sizes may vary up to the configurable maximum payload size (256 bytes):

- AXI4 transactions are limited to 256 bytes, and the received TLP is divided into several AXI4 transactions.
- AXI4 master receives a write transaction, processing it in 256-byte segments.
- TLP is de-constructed from the PCIe system and sent to the AXI4 interface in little-endian format.

#### 1.4.1.2. AXI Master Read Transactions [\(Ask a Question\)](#)

Read transactions are handled similar to write transactions, except that before transferring the transaction to the AXI4 master read channel, the PCI ESS checks the transmit buffer for available space. If the transmit replay buffer does not have sufficient place to store the PCIe completions, the PCI ESS does not transfer the read transaction. Hence, the number of outstanding AXI4 master read transactions is limited by the size of the transmit buffer. The maximum number of outstanding read transactions supported in non-DMA mode is four.

The AXI4 master read channel can receive transactions in any order, and data can be completely interleaved. However, the PCI ESS generates completions in the order they are initiated on the link.

### 1.4.2. AXI SlaveIF [\(Ask a Question\)](#)

The AXI4 slave interface forwards AXI read and write requests from the FPGA fabric to the PCIe link. The fabric application initiates PCIe transactions (memory write TLP and memory read TLP transactions) using the slave interface. The data on a read request comes back to the same interface. The slave path does not reorder transactions, but arbitrates between transactions if they occur simultaneously with master read completions. The order of priority for arbitrations is as follows:

1. Master read completions
2. Slave write requests
3. Slave read requests

#### 1.4.2.1. AXI Slave Write Transactions [\(Ask a Question\)](#)

Slave write transactions support incrementing address bursts, fixed bursts, wrapping bursts, and narrow type transfers. Data interleaving, however, is not supported. Data packets of a maximum of 2 K bytes can be created. Wait states are used if the buffer is full, or has less than 128 bytes of available space. Write responses are generated as soon as the last phase is over with support for up to eight outstanding write transactions.

#### 1.4.2.2. AXI Slave Read Transactions [\(Ask a Question\)](#)

PCI ESS generates a PCIe tag, arbitrates between write requests and completions, and then checks for available credits. An error response is generated if a timeout occurs or if a “completion with error” status is received. The maximum number of outstanding read transactions supported is four.

#### 1.4.3. AXI4 Limitations [\(Ask a Question\)](#)

Unsupported AXI4 features in the PCI ESS are:

- 8, 16, and 32 bits data bus widths.
- User-defined signals.
- Low-power interface.
- Exclusive accesses are not supported.

#### 1.4.4. Conversion Between PCIe and AXI Transactions [\(Ask a Question\)](#)

The PCI ESS converts AXI read and write transaction as described in the following sections:

##### 1.4.4.1. Conversion from PCIe Write to AXI Write Transactions [\(Ask a Question\)](#)

A single PCIe write transaction is converted into multiple AXI write transactions at the fabric interface whenever the AXI write address space crosses the negotiated maximum payload size boundary. For example, the negotiated maximum payload size is 256 Bytes, then the address boundaries are 0x000, 0x100, 0x200, 0x300, ..., 0xE00, 0xF00. In this case, a PCIe write transaction writes a TLP with payload of 24 Double-Words, that is,  $24 \times 4 = 96$  Bytes. The write transaction targets the contiguous AXI write addresses starting from 0x0005AAF0. With a payload size of 96 Bytes, the ending write address is  $0x0005AAF0 + 0x50 = 0x0005AB50$ , which crosses the 256 Byte boundary. The bridge breaks it into two AXI write transactions—AXI write transaction starting at 0x0005AAF0 with 16 Bytes and AXI write transaction starting at 0x0005AB00 with the remaining 80 Bytes.

##### 1.4.4.2. Conversion from PCIe Read to AXI Read Transactions [\(Ask a Question\)](#)

A single PCIe read transaction is converted into multiple AXI read transactions when the bridge complies with the following two constraints:

- When the PCIe read transaction targets AXI address space that crosses the negotiated maximum payload boundary, the fabric logic may still return with one single AXI burst transaction. In this case, the PCIe bridge breaks it into multiple separate PCIe read completions with AXI read data broken at the negotiated maximum payload boundary in AXI address space.

Read requests, which cross the address boundaries at integer multiples of RCB bytes may be completed using more than one completion, but the data must not be fragmented except along the following:

- The first completion starts with the address specified in the request, and ends at one of the following:
  - The address specified in the request plus the length specified by the request, that is, the entire request.

- An address boundary between the start and end of the request at an integer multiple of RCB bytes.
- The final completion ends with the address specified in the request plus the length specified by the request.
- All completions between, but no including, the first and final completions will be an integer multiple of RCB bytes in length.

**Note:** For a root complex, RCB can be configured to 64 Bytes or 128 Bytes using PCIE\_PEX\_SPC[15] register bit. For an Endpoint, RCB is always 128 bytes.

The following are the examples of AXI split transactions:

- Assume the negotiated maximum payload size is 256 Bytes. Memory read request with address of 0x10000 and length of 192 bytes can be completed by a root complex with a RCB value of 64 Bytes with one of the following combination of completions (bytes):
  - 192
  - 128, 64
  - 64, 128
  - 64, 64, 64
- Assume the negotiated maximum payload size is 256 Bytes. Memory read request with address of 0x10200h and length of 256 bytes can be completed by an Endpoint in one of the following combination of completions (bytes):
  - 256
  - 96, 160
  - 96, 128, 32
  - 224, 32

## 1.5. PCI ESS Configuration Interface [\(Ask a Question\)](#)

**Programmable FPGA Resources:** The registers required for the initial configuration of the PCI ESS are loaded based on the options selected in the Libero PCI ESS Configurator wizard. On device power-up, these values are automatically loaded into the configuration registers from the on-chip non-volatile memory during the design initialization process. The design initialization uses the dedicated resources to bring up the PCI ESS features at power-up or device reset. This does not require any programmable FPGA user resources. The PCI ESS then reads and writes the configuration space registers as the link comes up and the endpoint device is enumerated into the host system.

PCI ESS can be dynamically configured through the following interfaces:

- DRI – is used to configure transceiver lane registers.
- APB – is used to configure PCIe control registers.

## 1.6. PCI ESS Port List [\(Ask a Question\)](#)

The PCI ESS block is generated using the Libero PCIe Configurator. The generation of the PCI ESS block includes ports based on the PCIe Configurator settings. The following table lists the port descriptions. The PCI ESS also has several status signals, interrupt signals, and power management signals available to the FPGA fabric.

**Table 1-3.** PCI ESS Port List<sup>1, 2</sup>

Port Name	Direction	Description
AXI_CLK	Input	Global AXI clock. Shared for both PCI ESS interfaces.
AXI_CLK_STABLE	Input	Clock lock signal. Indicates that the AXI_CLK source from the fabric is locked and ready for use.

**Table 1-3. PCIess Port List<sup>1, 2</sup> (continued)**

Port Name	Direction	Description
<b>Master</b>		
PCIess_AXI_#_M_ARADDR[31:0]	Output	Read address. The address of the first transfer in a read burst transaction.
PCIess_AXI_#_M_ARBURST[1:0]	Output	Read burst type. The burst type and the size details determine how the address for each transfer within the burst is calculated.
PCIess_AXI_#_M_ARID[3:0]	Output	Read address ID. Identification tag for the read address group of signals.
PCIess_AXI_#_M_ARLEN[7:0]	Output	Burst length. Indicates the exact number of transfers in a burst.
PCIess_AXI_#_M_ARREADY	Input	Read address ready. Indicates that the slave is ready to accept an address and associated control signals.
PCIess_AXI_#_M_ARSIZE[2:0]	Output	Burst size. Indicates the size of each transfer in the burst.
PCIess_AXI_#_M_ARVALID	Output	Read address valid. Indicates that the channel is signaling valid read address and control information.
PCIess_AXI_#_M_AWADDR[31:0]	Output	Write address. The address of the first transfer in a write burst transaction.
PCIess_AXI_#_M_AWBURST[1:0]	Output	Write burst type. The burst type and the size of information determine how the address for each transfer within the burst is calculated.
PCIess_AXI_#_M_AWID[3:0]	Output	Write address ID. Identification tag for the write address group of signals.
PCIess_AXI_#_M_AWLEN[7:0]	Output	Burst length. Indicates the exact number of transfers in a burst, which determines the number of data transfers associated with the address.
PCIess_AXI_#_M_AWREADY	Input	Write address ready. Indicates that the slave is ready to accept an address and associated control signals.
PCIess_AXI_#_M_AWSIZE[2:0]	Output	Burst size. Indicates the size of each transfer in the burst.
PCIess_AXI_#_M_AWVALID	Output	Write address valid. Indicates that the channel is signaling valid write address and control information.
PCIess_AXI_#_M_BID[3:0]	Input	Response ID tag. Identification tag for the write response.
PCIess_AXI_#_M_BREADY	Output	Response ready. Indicates that the master is ready to accept a write response.
PCIess_AXI_#_M_BRESP[1:0]	Input	Write response. Indicates the status of the write transaction. When it is asserted to 2'b10 (SLVERR/DECERR), unsupported request to PCIe is reported.
PCIess_AXI_#_M_BVALID	Input	Write response valid. Indicates that the channel is signaling a valid write response.
PCIess_AXI_#_M_RDATA[63:0]	Input	Read data.
PCIess_AXI_#_M_RID[3:0]	Input	Read ID tag. Identification tag for the read data group of signals generated by the slave.
PCIess_AXI_#_M_RLAST	Input	Read last. Indicates the last transfer in a read burst.
PCIess_AXI_#_M_RREADY	Output	Read ready. Indicates that the master can accept the read data and associated control signals, along with response information.
PCIess_AXI_#_M_RRESP[1:0]	Input	Read response. Indicates the status of the read transfer. <ul style="list-style-type: none"> <li>When it is asserted to 2'b10 (SLVERR), completion with Unsupported Request status is returned.</li> <li>When it is asserted to 2'b11 (DECERR), completion with Completion Abort status is returned.</li> </ul>
PCIess_AXI_#_M_RVALID	Input	Read valid. Indicates that the channel is signaling the required read data.
PCIess_AXI_#_M_WDATA[63:0]	Output	Write data.
PCIess_AXI_#_M_WLAST	Output	Write last. Indicates the last transfer in a write burst.
PCIess_AXI_#_M_WREADY	Input	Write ready. Indicates that the slave can accept the write data.

**Table 1-3. PCI ESS Port List<sup>1, 2</sup> (continued)**

Port Name	Direction	Description
PCI ESS_AXI_#_M_WSTRB[7:0]	Output	Write strobes. Indicates the byte lanes that hold valid data. There is one write strobe bit for every eight bits of the write data bus.
PCI ESS_AXI_#_M_WVALID	Output	Write valid. Indicates that valid write data and strobes are available.
<b>Slave</b>		
PCI ESS_AXI_#_S_ARADDR[31:0]	Input	Read address. The address of the first transfer in a read burst transaction.
PCI ESS_AXI_#_S_ARBURST[1:0]	Input	Burst type. The burst type and the size of information determine how the address for each transfer within the burst is calculated.
PCI ESS_AXI_#_S_ARID[3:0]	Input	Read address ID. Identification tag for the read address group of signals.
PCI ESS_AXI_#_S_ARLEN[7:0]	Input	Burst length. Indicates the exact number of transfers in a burst.
PCI ESS_AXI_#_S_ARREADY	Output	Write address ready. Indicates that the slave is ready to accept an address and the associated control signals.
PCI ESS_AXI_#_S_ARSIZE[2:0]	Input	Burst size. Indicates the size of each transfer in the burst.
PCI ESS_AXI_#_S_ARVALID	Input	Read address valid. Indicates that the channel is signaling valid read address and control information.
PCI ESS_AXI_#_S_AWADDR[31:0]	Input	Write address. Address of the first transfer in a write burst transaction.
PCI ESS_AXI_#_S_AWBURST[1:0]	Input	Burst type. The burst type and the size information determine how the address for each transfer within the burst is calculated.
PCI ESS_AXI_#_S_AWID[3:0]	Input	Write address ID. Identification tag for the write address group of signals.
PCI ESS_AXI_#_S_AWLEN[7:0]	Input	Burst length. Indicates the exact number of transfers in a burst, which determines the number of data transfers associated with the address.
PCI ESS_AXI_#_S_AWREADY	Output	Write address ready. Indicates that the slave is ready to accept an address and associated control signals.
PCI ESS_AXI_#_S_AWSIZE[2:0]	Input	Burst size. Indicates the size of each transfer in the burst.
PCI ESS_AXI_#_S_AWVALID	Input	Write address valid. Indicates that the channel is signaling valid write address and control information.
PCI ESS_AXI_#_S_BID[3:0]	Output	Response ID tag. Identification tag for the write response.
PCI ESS_AXI_#_S_BREADY	Input	Response ready. Indicates that the master can accept a write response.
PCI ESS_AXI_#_S_BRESP[1:0]	Output	Write response. Indicates the status of the write transaction. It is asserted to 2'b10(SLVERR), when: <ul style="list-style-type: none"> <li>An AXI Write Completion Timeout (128 ms in hardware and 128 <math>\mu</math>s in simulation) cannot be transferred to the PCIe link due to an AXI write transaction, because the link is down or in low-power mode.</li> <li>ECRC error occurs in TLP/Poisoned TLP.</li> </ul> It is asserted to 2'b11(DECERR) when no address translation table is matched (Unsupported Address).
PCI ESS_AXI_#_S_BVALID	Output	Write response valid. Indicates that the channel is signaling a valid write response.
PCI ESS_AXI_#_S_RDATA[63:0]	Output	Read data.
PCI ESS_AXI_#_S_RID[3:0]	Output	Read ID tag. Identification tag for the read data group of signals generated by the slave.
PCI ESS_AXI_#_S_RLAST	Output	Read last. Indicates the last transfer in a read burst.
PCI ESS_AXI_#_S_RREADY	Input	Read ready. Indicates that the master can accept the read data and response information.

**Table 1-3. PCI ESS Port List<sup>1, 2</sup> (continued)**

Port Name	Direction	Description
PCI ESS_AXI_#_S_RRESP[1:0]	Output	Read response. Indicates the status of the read transfer. It is asserted to 2'b10(SLVERR), when: <ul style="list-style-type: none"> <li>• PCIe Completion TLP with Unsupported Request (UR) Status</li> <li>• ECRC error/Poisoned TLP occurs.</li> </ul> It is asserted to 2'b11(DECERR), when: <ul style="list-style-type: none"> <li>- No address translation table is matched (Unsupported Address)</li> <li>- PCIe Completion TLP with Completer Abort (CA) status</li> </ul>
PCI ESS_AXI_#_S_RVALID	Output	Read valid. Indicates that the channel is signaling the required read data.
PCI ESS_AXI_#_S_WDATA[63:0]	Input	Write data.
PCI ESS_AXI_#_S_WLAST	Input	Write last. Indicates the last transfer in a write burst.
PCI ESS_AXI_#_S_WREADY	Output	Write ready. Indicates that the slave can accept the write data.
PCI ESS_AXI_#_S_WSTRB[7:0]	Input	Write strobes. Indicates the byte lanes that hold valid data. There is one write strobe bit for each eight bits of the write data bus.
PCI ESS_AXI_#_S_WVALID	Input	Write valid. Indicates that valid write data and strobes are available.
<b>PCIe</b>		
PCIE_#_M_RDERR	Input	Tie to 0
PCIE_#_M_WDERR	Output	Not connected
PCIE_#_S_RDERR	Output	Not connected
PCIE_#_S_WDERR	Input	Tie to 0
PCIE_#_HOT_RST_EXIT	Output	Hot reset exit. Asserted for one clock cycle when the LTSSM exits Hot Reset state. Prompts the application layer to perform a global reset.
PCIE_#_DLUP_EXIT	Output	DL-up exit. Indicates transition from DL_UP to DL_DOWN. <ul style="list-style-type: none"> <li>• dlup_exit = 1'b0, data link layer is down</li> <li>• dlup_exit = 1'b1, data link layer is up only valid when LTSSM is in L0 state</li> </ul>
PCIE_#_INTERRUPT[7:0]	Input	Local interrupt input ports. The fabric logic can drive up to eight interrupt sources by generating a pulse (high) on the ports and the clock pluses are asserted. [7:0] can be used for MSI. [0] is also available for INTx. Used only for endpoints. PCI ESS uses TL_CLK to monitor this signal. MSI offsets are [negotiated interrupt-1:negotiated interrupt-8]
PCIE_#_INTERRUPT_OUT	Output	Local interrupt output port. Indicates that one of the possible interrupt sources was detected and the user can read the interrupt through the DRI. It is a level sensitive signal; whenever an interrupt described in ISTATUS_LOCAL, SEC_ERROR_INT register, DED_ERROR_INT register, and PCIE_EVENT_INT register is active, the PCIE_#_INTERRUPT_OUT signal gets asserted and remains high. It is low when the corresponding interrupts in the registers are cleared.

**Table 1-3. PCISS Port List<sup>1, 2</sup> (continued)**

Port Name	Direction	Description
PCIE_#_LTSSM[4:0]	Output	LTSSM state encoding: 0x0: LTSSM_DET_QUIET 0x1: LTSSM_DET_ACT 0x2: LTSSM_POL_ACT 0x3: LTSSM_POL_COMP 0x4: LTSSM_POL_CFG 0x5: LTSSM_CFG_LWSTR 0x6: LTSSM_CFG_LWACC 0x7: LTSSM_CFG_LWAIT 0x8: LTSSM_CFG_LNACC 0x9: LTSSM_CFG_CPLT 0xa: LTSSM_CFG_IDLE 0xb: LTSSM_RCV_RLOCK 0xc: LTSSM_RCV_EQL 0xd: LTSSM_RCV_SPEED 0xe: LTSSM_RCV_RCFG 0xf: LTSSM_RCV_IDLE 0x10: LTSSM_L0 0x11: LTSSM_L0S 0x12: LTSSM_L1_ENTRY 0x13: LTSSM_L1_IDLE 0x14: Reserved 0x15: Reserved 0x16: LTSSM_DISABLED 0x17: LTSSM_LOOPBACK_ENTRY 0x18: LTSSM_LOOPBACK_ACTIVE 0x19: LTSSM_LOOPBACK_EXIT 0x1a: LTSSM_HOTRESET
PCIE_#_PERST_N	Input	Asynchronous. PERST_N can use any GPIO.
PCIE_#_TL_CLK_125MHz	Input	125 MHz (maximum) clock input. Continuous running clock is required for PCIe core transaction layer. Connects to the DIV_CLK output from the TX_PLL. TL_CLK is available only after PCIe initialization. User have to derive from the on-chip oscillator to drive the TL_CLK during PCIe initialization. An NGMUX can be used to switch this clock to the required DIV_CLK after PCIe initialization. For information about PolarFire FPGA reference design, see <a href="#">PolarFire FPGA PCIe EndPoint DDR3L DDR4 Memory Controller Data Plane</a> . For information about PolarFire SoC FPGA Linux reference design, see <a href="#">GitHub</a> .
<b>Transceiver</b>		
CLKS_FROM_TXPLL_TO_PCIE_#	Input	PCIE_#_TX_BIT_CLK_#: This port must be driven by the BIT_CLK output of the Tx PLL. Gen1 2.5 G, Gen2 5 G, and mix of Gen 1 and Gen 2 is 2.5 G. PCIE_#_TX_PLL_REF_CLK_#: Reference clock from TX_PLL. PCIE_#_TX_PLL_LOCK_#: Lock status input to PCISS. Connects to the lock output of the TX_PLL.
PCISS_LANE#_CDR_REF_CLK_#	Input	Reference clock to lane CDR. Connects to the REF_CLK input of the TX_PLL.

**Table 1-3. PCI ESS Port List<sup>1, 2</sup> (continued)**

Port Name	Direction	Description
PCI ESS_LANE_TXDn_P	Output	Transceiver differential output transmit data. n = 0, 1, 2, 3.
PCI ESS_LANE_TXDn_N		
PCI ESS_LANE_RXDn_P	Output	Transceiver differential input receive data. n = 0, 1, 2, 3.
PCI ESS_LANE_RXDn_N		

**Notes:**

1. Unless otherwise indicated, all signals are active-high.
2. # = 0, 1.



The following figure shows the PCIe IP configurator settings for PCIe Root Port in PolarFire SoC FPGA.

**Figure 2-2.** PCI Express Configurator

Configurator

## PCI Express

Microsemi:SgCore:PF\_PCIE:2.0.116

General | Identification | Power Management | Interrupts and Auxiliary Settings | Master Settings | Slave Settings

	PCIe 0	PCIe 1
PCIe Controller	Disabled	Enabled
Port Type	--	Root Port
Number of Lanes	--	x4
Lane Rate	--	Gen2 (5.0 Gbps)
Reference Clock Frequency	--	100
CDR Reference Clock Source	--	Dedicated
Number of CDR Reference Clocks	--	1

**General Settings**

- Use embedded DLL in fabric interface **i**  
 Embedded DLL Jitter Range: Medium Low
- TX PLL base data rate: -- 5000 Mbps
- TX PLL bit clock frequency: -- 2500 MHz

**Optional Interfaces**

- Enable APB slave interface (PCIe controller access)
- Enable Dynamic Reconfiguration Interface (DRI) for XCVR lane access

**Simulation Level Settings**

Simulation Level: RTL

The following figure shows the Identification tab in the PCI Express configurator.

Figure 2-3. Identification Tab

PCI Express	
Microsemi:SgCore:PF_PCIE:2.0.106	
General   <b>Identification</b>   Power Management   Interrupts and Auxiliary Settings   Master Settings   Slave Settings	
	<b>PCIe 1</b>
Vendor ID	0x11AA
Sub-System Vendor ID	0x0000
Revision ID	0x0000
Device ID	0x1556
Sub-System Device ID	0x0000
Class Code	0x0604

The following figure shows the Power Management tab in the PCI Express configurator.

Figure 2-4. PCIe Power Management Settings

General   Identification   <b>Power Management</b>   Interrupts and Auxiliary Settings   Master Settings   Slave Settings	
	<b>PCIe 0</b>
Number of FTS	63
L0s Acceptable Latency	No limit
Enable L1 Capability	Disabled
L1 Acceptable Latency	--
L1 Exit Latency	--

The following figure shows the Interrupts and Auxiliary Settings tab in the PCI Express configurator.

Figure 2-5. PCIe Interrupts and Auxiliary Settings

General   Identification   Power Management   <b>Interrupts and Auxiliary Settings</b>   Master Settings   Slave Settings	
	<b>PCIe 0</b>
PHY Reference Clock Slot	Slot
Interrupts	MSI1
Expose Wake Signal	Disabled
Transmit Swing	Full Swing
De-Emphasis	--

The following figure shows the Master Settings tab in the PCI Express configurator.

Figure 2-6. Master Settings Tab

Bar 0 Table	
	PCIe 1
BAR Type	64-bit prefetchable memory
BAR Size	2 GB
AXI Address (32 bit)	0x0000

The following figure shows the Slave Settings tab in the PCI Express configurator.

Figure 2-7. Slave Settings Tab

Slave 0 Table	
	PCIe 1
State	Enabled
Size	4 KB
AXI Address (32 bit)	0x0000
Translation Address (64 bit)	0x0000

## References

- For information about DRI, see [PolarFire Family DRI User Guide](#).
- For information about PolarFire SoC PCIe Root Port Linux reference design, see [GitHub](#).
- For information about PolarFire SoC HSS, see [GitHub](#).
- For information about Yocto BSP, see [GitHub](#).

### 3. Implementation (Ask a Question)

The PCIe core uses several embedded blocks that are built using Libero configurators. PCIeSS functionality is reserved for the Quad0 transceiver block, and this functionality allows up to two x1 or x2 PCIe endpoint/root ports links or one x4 PCIe endpoint/root port link. PCIe 0 and PCIe 1 blocks can be used in any combination of x1 and x2 links within Quad0. A PCIe x4 link is only supported using PCIe 1, PCIe 0 is unused. The Libero configurator allows the setting of the reference clock and data rates for the PCIe block. This information is used to generate the configuration settings for the PMA as well as associated interface logic. The configurators build the components that are used to instantiate/configure specific hardware macros including the PMA and PCS blocks using the Libero SmartDesign software.

Lane[0:1] and Lane[2:3] share on-chip hardware resources that create inter-dependency between the physical lanes. The possible combinations for implementing and mixing the PCIe controllers on four physical XCVR lanes within QUAD0 are shown in the following figure.

**Figure 3-1. Legal Combinations of PCIe and XCVR Protocols**

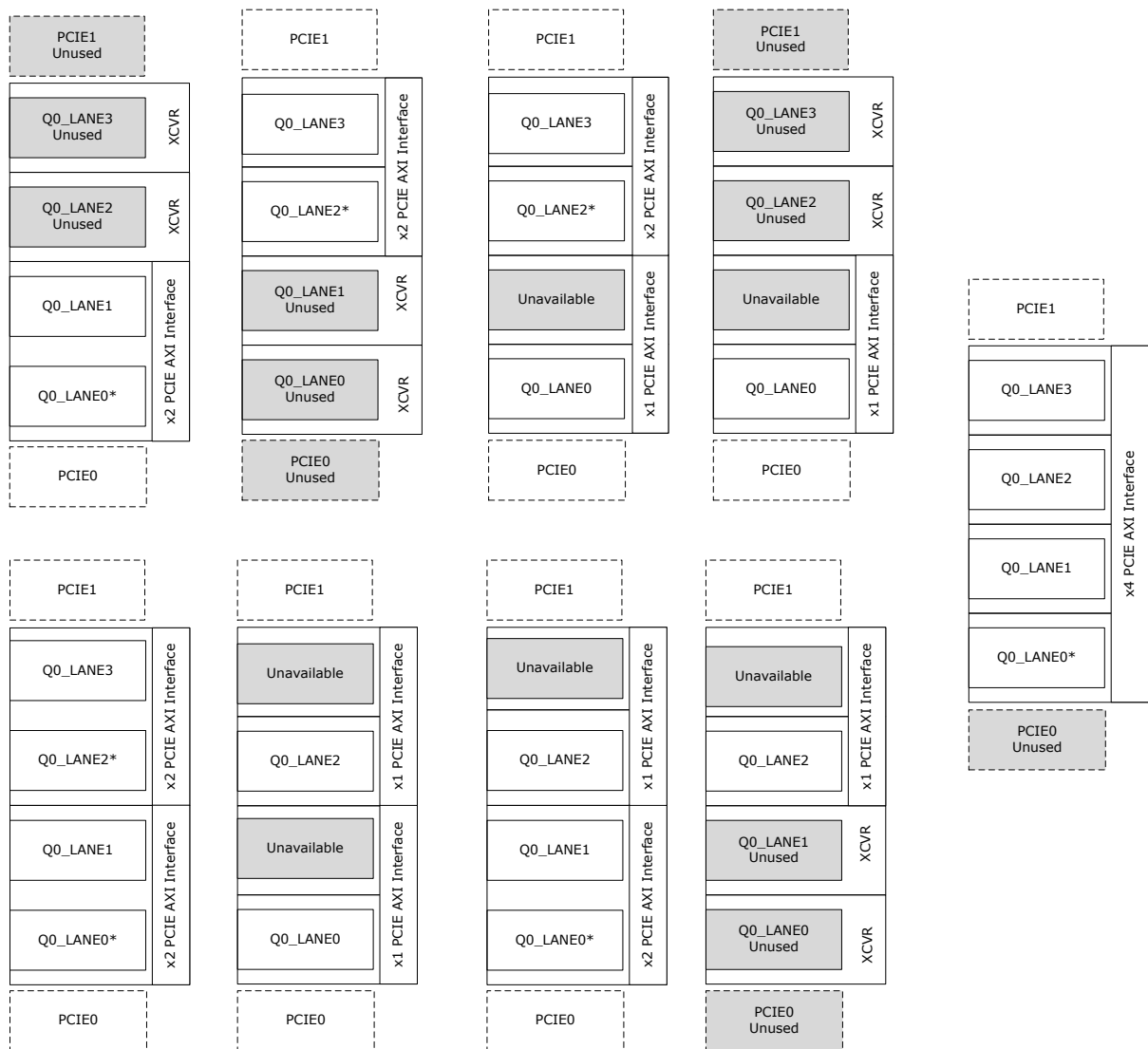

\* Denotes the x1 downgrade lane for a x2 or x4 link  
 Unused: Can use for any other protocol

### 3.1. Libero Configurators [\(Ask a Question\)](#)

The transceiver configurator is the preferred tool for the wrapper generation needed to instantiate the transceiver primitive macros called PF\_XCVR\_REF\_CLK, PF\_TXPLL, and PF\_PCIE. The configurator is part of the Libero SoC design tools and is available when the macros are downloaded into the Libero catalog. This section describes how to enter the configuration parameters in the Libero configurator GUIs. The following table provides details of three Libero configurator modules used by the Libero FPGA design when the blocks are implemented in the design. These three blocks must be instantiated and configured in the PCIe design.

**Table 3-1.** Libero Configurators in Libero Software

Libero Configurator	Macro	Details
Transceiver Reference Clock	PF_XCVR_REF_CLK	Generates the reference clock based on the input to the GUI—differential or single-ended input buffer and single or dual-clock input to the transmit PLL clock network. Reference clocks for PCI ESS systems use differential HCSL/LVDS. However, this can vary according to the system application.
Transmit PLL <sup>1</sup>	PF_TXPLL	Generates the TxPLL/TxPLL_SSC based on the input to the GUI. Typically, a 100 MHz clock (Refclk) with greater than ±300 ppm frequency stability is used for PCIe applications. For Refclk flexibility, the PCI ESS block accepts 100 MHz, 125 MHz, or 156.25 MHz input and translates for PCIe Gen1 or Gen2 speeds.
PCI Express	PF_PCIE	Configures the requested number of lanes with the same PMA and PCS settings—location of each lane and CDRPLL settings. The configurator has presets for all the supported protocols.

<sup>(1)</sup> It is not advisable to share the TxPLL with other serial protocols that have a tight transmit jitter specification.

Each transceiver module configurator guides the user through a sequential selection of choices and defaults. Each configurator maintains a macro diagram that displays module ports based on the current configuration. When all of the choices are made, the configurator generates a macro specific to the requirements of the design. Only the relevant ports appear in the generated macro.

A PCIe design requires the transceiver reference clock and transceivers transmit PLL blocks to be configured and instantiated in the design.

For more information on TX\_REF\_CLK and TX\_PLL block configurators, see [PolarFire Family Transceiver User Guide](#).

For information about how to debug PCIe, see [SmartDebug User Guide](#).

### 3.2. PCIe Configurator [\(Ask a Question\)](#)

The PCIe configurator is used to build a PCIe endpoint or root port PCIe block. The configurator sets up the correct PCI ESS registers and ports based on the user inputs.

To create a configured PCIe component, follow the steps:

1. Access the PCIe module in the Features from the catalog, as shown in the following figure. Double click **PCI Express**; the **Create Component** dialog box is displayed.

Figure 3-2. PCIe Selection from Catalog

Name	Version
Peripherals	
PCI Express	2.0.100
PolarFire Features	
PCI Express	2.0.100

2. Enter the name of the component and then click **OK** to launch the configurator, as shown in the following figure. The GUI allows you to select the related PCIe properties.

Figure 3-3. PCIe General Settings

The following table lists the options available in the General tab.

Table 3-2. PCIe General Settings

PCIe General Settings (PCIe 0 and PCIe 1)	Options	Default
PCIe Controller	Enabled and Disabled	PCIe 0 = Enabled PCIe 1 = Disabled
Port Type	End Point and Root Port <sup>1</sup>	End Point
Number of Lanes	x1, x2, and x4	x1
Lane Rate	Gen1 (2.5 Gbps) and Gen2 (5.0 Gbps)	PCIe 0 = Enabled PCIe 1 = Disabled
Reference Clock Frequency (MHz)	100, 125, and 156.25	100
CDR Reference Clock Source	Dedicated and Fabric	Dedicated
Number of CDR Reference Clocks	1 and 2	1
Embedded DLL in fabric interface <sup>2</sup>	Enabled and Disabled	Enabled
Embedded DLL Jitter Range	Low, Medium-Low, Medium-High, and High	Medium-Low
<b>Optional Interfaces</b>		
APB Slave Interface <sup>3,4</sup>	Enabled and Disabled	Disabled

**Table 3-2.** PCIe General Settings (continued)

PCIe General Settings (PCIe 0 and PCIe 1)	Options	Default
DRI Slave Interface <sup>5</sup>	Enabled and Disabled	Disabled

**Notes:**

1. The PCIe Slot Capabilities register of PolarFire SoC FPGA is a read-only register and the Slot Power Limit and Slot Power Scale fields are hardwired to zeros. Hence, the PCIe Root Port advertises the Slot Power Limit as zero to the add-in card. However, the PCIe endpoints whose power requirement is 25W or below work as expected. For PCIe endpoints whose power requirement is more than 25W or needs a strict adherence to PCIe spec, it is recommended to connect the endpoint through a Microchip SwitchTec Gen3 PCIe Switch.
2. AXI clock frequency must be greater than or equal to 125 MHz when the embedded DLL is enabled. Select the **Use embedded DLL in the fabric interface** option for removing clock insertion delay.
3. APB interface is used to configure PCIe control registers.
4. The PCIe APB\_S\_CLK supports a frequency range between 50 MHz to 125 MHz.
5. For PolarFire SoC FPGA, DRI interface is used to configure lane related registers.

**Number of Lanes:** PCIe requires selection of the initial lane width. Wider lane-width cores are capable of training down to smaller lane widths if attached to smaller lane-width devices. The configurations, x2 and x4 support automatic lane reversal, allowing the PCIe link to permit board interconnections with reversed lane numbers, and the PCISS continues to link train successfully and operate normally.

**Reference Clock Frequency:** PCISS requires a 100 MHz, 125 MHz, or 156.25 MHz clock input. The specified clock frequency must match with the TXPLL clock frequency.

**Optional Interfaces (APB Slave/DRI Slave):** Enabling these options, exposes the particular bus on the PCISS component for connecting to the FPGA fabric of the APB and DRI.

The following figure shows the options available in the Identification tab.

**Figure 3-4.** PCIe Identification Settings

	PCIe 0
Vendor ID	0x11AA
Sub-System Vendor ID	0x0000
Revision ID	0x0000
Device ID	0x1556
Sub-System Device ID	0x0000
Class Code	0x0000

The following table lists the options available in the Identification tab.

**Table 3-3.** PCIe Identification Settings

PCIe Identification Settings (PCIe 0 and PCIe 1)	Options	Default
Vendor ID	User Input	0x11AA

**Table 3-3. PCIe Identification Settings (continued)**

PCIe Identification Settings (PCIe 0 and PCIe 1)	Options	Default
Sub-System Vendor ID	User Programmable	0x0000
Revision ID	User Input	0x0000
Device ID	User Input	0x1556
Sub-System Device ID	User Input	0x0000
Class Code	User Input	0x0000

**Vendor ID:** It identifies the manufacturer of the device or application. The default value (0x11AA) is the vendor ID of Microchip and is registered with PCI-Sig. Customized vendor identification IDs can also be used.

**Sub-System Vendor ID:** This ID further qualifies the manufacturer of the device or application. The default value is 0x0000 matching the vendor ID. Customized vendor identification IDs can also be used.

**Important:**

- 0x0000 is not recommended for vendor IDs or sub-system vendor ID.
- SSVID/SSDID value of 0x0000 causes the Endpoint to fail the PCIECV compliance tests when non-zero SSVID/SSDID is a requirement by the PCIe specification.

**Revision ID:** This indicates the revision of the device or application; an extension of the device ID. The default value is 0x0000. Customized revision IDs can also be used.

**Device ID:** A unique identifier for the application. This can be any value based on the input.

**Sub-System Device ID:** This is similar to sub-system vendor ID and further qualifies the device application.

**Class Code:** The class code identifies the general function of a device, and is divided into three byte-size fields:

- Base Class: Broadly identifies the type of the function performed by the device.
- Sub-Class: More specifically identifies the device function.
- Interface: Defines a specific register-level programming interface.

Class code encoding details can be found at [www.pcisig.com](http://www.pcisig.com).

The following figure shows the options available in the Power Management tab. Selecting the power management option allows loading settings to the PCIe config space headers.

Figure 3-5. PCIe Power Management Settings

General	Identification	Power Management	Interrupts and Auxiliary Settings	Master Settings	Slave Settings
		<b>PCIe 0</b>			
		<b>Number of FTS</b>	63		
		<b>L0s Acceptable Latency</b>	No limit		
		<b>Enable L1 Capability</b>	Disabled		
		<b>L1 Acceptable Latency</b>	--		
		<b>L1 Exit Latency</b>	--		

The following table lists the options available in the Power Management tab.

Table 3-4. PCIe Power Management Settings

PCIe Power Management Settings (PCIe 0 and PCIe 1)	Options	Default
Number of Fast Training Sequences (FTS)	—	63 (Not configurable by the user)
L0 Standby (L0s) Acceptable Latency	No Limit Maximum of 64 ns Maximum of 128 ns Maximum of 256 ns Maximum of 512 ns Maximum of 1 $\mu$ s Maximum of 2 $\mu$ s Maximum of 4 $\mu$ s	No Limit
Enable L1 Capability	Disabled and Enabled	Disabled
L1 Acceptable Latency	No Limit Maximum of 1 $\mu$ s Maximum of 2 $\mu$ s Maximum of 4 $\mu$ s Maximum of 8 $\mu$ s Maximum of 16 $\mu$ s Maximum of 32 $\mu$ s Maximum of 64 $\mu$ s	No Limit
L1 Exit Latency	Less than 1 $\mu$ s 1 $\mu$ s less than 2 $\mu$ s 2 $\mu$ s less than 4 $\mu$ s 4 $\mu$ s less than 8 $\mu$ s 8 $\mu$ s less than 16 $\mu$ s 16 $\mu$ s less than 32 $\mu$ s 32 $\mu$ s to 64 $\mu$ s more than 64 $\mu$ s	16 $\mu$ s to less than 32 $\mu$ s

The PCIe base specification defines two levels of active state power management (ASPM) that are designed to provide options for trading off increased power conservation with rapid recovery to the L0 state.

**Number of fast training sequences (FTS):** The specific number to be repeated is defined by the receiving device and broadcast during training sequences at the link up time. The more FTS

transmitted, the easier it is to obtain a receiver lock on the transmitted signal. By default, the number of FTS is grayed out, fixed to 63, and is not configurable by the user.

**L0s Acceptable Latency:** This state is required by all the PCIe devices and applies to a single direction on the link. The latency to return to L0 from L0s is specified to be very short. When entering L0s, the device moving into the power saving state sends an electrical idle ordered set (EIOS) to the receiving device, and then turn off the power to its transmitter. When returning from L0s to L0, the device must first generate a specific number of small order known as FTS. However, the purpose of L0s is to regain receiver lock and be able to receive traffic as quickly as possible, so the receiving device selects the lowest number of FTS that ensure clock recovery based on its specific design. This selection is used to choose a time interval to achieve L0s.

**Enable L1 Compatibility:** The L1 ASPM is optionally enabled and can be entered to achieve a greater degree of power conservation. In this state, both directions of the link are placed in the L1 state. Return to L0 requires both devices to go through the link recovery process which results in a greater latency to return to L0, so that the power state can typically be used when activity on the link is not expected for some significant time period.

**L1 Acceptable Latency:** To enter the L1 state, the downstream device must first request permission from the upstream device for entering in to a deeper power conservation state. Upon acknowledgement, both devices turn off their transmitters and enter an electrical idle state. This settings gives the allowable time to wait to achieve L1.

**L1 Exit Latency:** Returning from L1 requires, that both devices must now go through the link recovery process. The link recovery process uses TS1 and TS2 standard ordered sets as opposed to the smaller FTSs used by L0s. This setting selects the time interval to exit from L1.



**Important:** When Enable, L1 capability is enabled.

The following figure shows the options available in the Interrupts and Auxiliary Settings tab.

**Figure 3-6.** PCIe Interrupts and Auxiliary Settings

General	Identification	Power Management	Interrupts and Auxiliary Settings	Master Settings	Slave Settings
		<b>PCIe 0</b>			
<b>PHY Reference Clock Slot</b>		Slot			
<b>Interrupts</b>		MSI1			
<b>Expose Wake Signal</b>		Disabled			
<b>Transmit Swing</b>		Full Swing			
<b>De-Emphasis</b>		--			

The following table lists the options available in the Interrupt and Auxiliary Settings tab.

**Table 3-5.** PCIe Interrupts and Auxiliary Settings

PCIe Interrupts and Auxiliary Settings (PCIe 0 and PCIe 1)	Options	Default
Physical layer reference clock slot	Slot and Independent	Slot
Interrupts	INTx, MSI 1, MSI 2, MSI 4, MSI 8, MSI 16, and MSI 32	INTx
Expose wake signals <sup>1</sup>	Enabled and Disabled	Enabled

**Table 3-5. PCIe Interrupts and Auxiliary Settings (continued)**

PCIe Interrupts and Auxiliary Settings (PCIe 0 and PCIe 1)	Options	Default
Transmit swing	—	Full swing (Not configurable by the user)
De-Emphasis	-3.5 dB and -6 dB	-3.5 dB

(1) Enabled for End Point port type and disabled for Root Port by default.

**PHY Reference Clock Slot:** Select this option, if the PHY reference clock is either from a PCIe slot or is generated separately. Slot is a clock source shared in the PCIe system between the host and endpoint link. An Independent slot is used in a system that uses the independent clock sources on either side of the link. This setting changes the PCIe configuration space register, to advertise the used clocked topology to the system root. It makes no other functional changes to the endpoint.

**Interrupts:** The PCIe EP implementation supports 32 MSI interrupt and INTx interrupts. It cannot simultaneously support both the interrupts. The PCIe EP supports legacy INT A interrupt as PolarFire is a single-function device.

**Expose Wake Signals:** Enabling this option, exposes the WAKE\_N input signal on the PCISS component allowing connection to the FPGA fabric.

**De-Emphasis:** This sets the de-emphasis (3.5 dB and 6.0 dB) for PCIe GEN 2 speed.

The following figure shows the options available in the Master Settings tab.

**Figure 3-7.** PCIe Master Settings

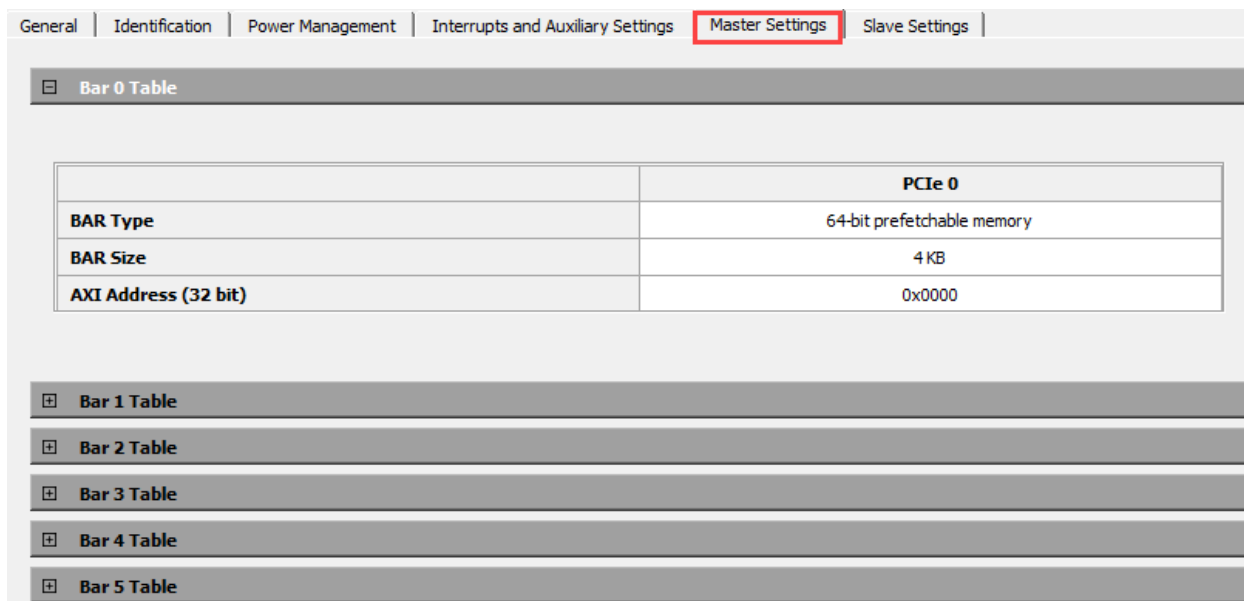

The following table lists the options available in the Master Settings tab.

**Table 3-6.** PCIe Master Settings

PCIe Master Settings (PCIe 0 and PCIe 1)	Options	Default
BAR Type	Disabled, 32-bit memory, 32-bit prefetchable memory, and 64-bit prefetchable memory	32-bit memory
BAR Size	4 KB, 8 KB, 16 KB, 32 KB, 64 KB, 128 KB, 256 KB, 512 KB, 1 MB, 2 MB, 4 MB, 8 MB, 16 MB, 32 MB, 64 MB, 128 MB, 256 MB, 512 MB, 1 GB, 2 GB, and 4 GB	4 KB
AXI Address [32 bit]	User Input, 32-bit address to be entered, lower 12 bits must be zero.	0x0000

 **Important:** At least one Master Bar must be enabled for PCIe 0 and PCIe 1 controllers.

The following figure shows the options available in the Slave Settings tab.

**Figure 3-8.** PCIe Slave Settings

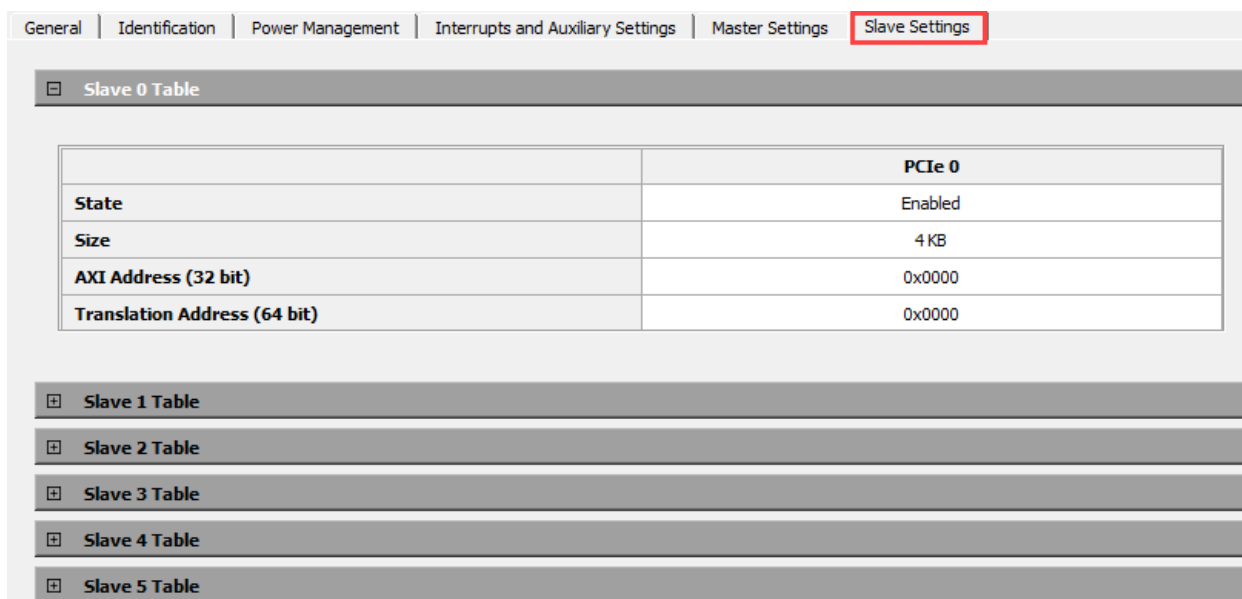

The following table lists the options available in the Slave Settings tab.

**Table 3-7.** PCIe Slave Settings

PCIE Slave Settings (PCIe 0 and PCIe 1)	Options	Default
State	Disabled Enabled	Disabled
Size	4 KB, 8 KB, 16 KB, 32 KB, 64 KB, 128 KB, 256 KB, 512 KB, 1 MB, 2 MB, 4 MB, 8 MB, 16 MB, 32 MB, 64 MB, 128 MB, 256 MB, 512 MB, 1 GB, 2 GB, and 4 GB	4 KB
AXI Address [32 bit]	User Input, 32-bit address to be entered, lower 12 bits must be zero.	0x0000
Translation Address [64 bit]	User Input, 64-bit address to be entered, lower 12 bits must be zero.	0x0000

**➔ Important:** When State is enabled, the size, AXI address, and translation address settings are available.

After making all selections in the PCIe configurator, complete the generation by clicking **OK**.

The next step is to create the XCVR\_REFCLK and TX\_PLL modules to be instantiated and connected to the PCIe block. Typically, the REF\_CLK output of the PF\_XCVR\_REF\_CLK is connected to the respective inputs of the PF\_PCIE as well as the input REF\_CLK of the PF\_TX\_PLL. For information on XCVR block generation, see [PolarFire Family Transceiver User Guide](#).

Figure 3-9. Complete PCIe Interface Example

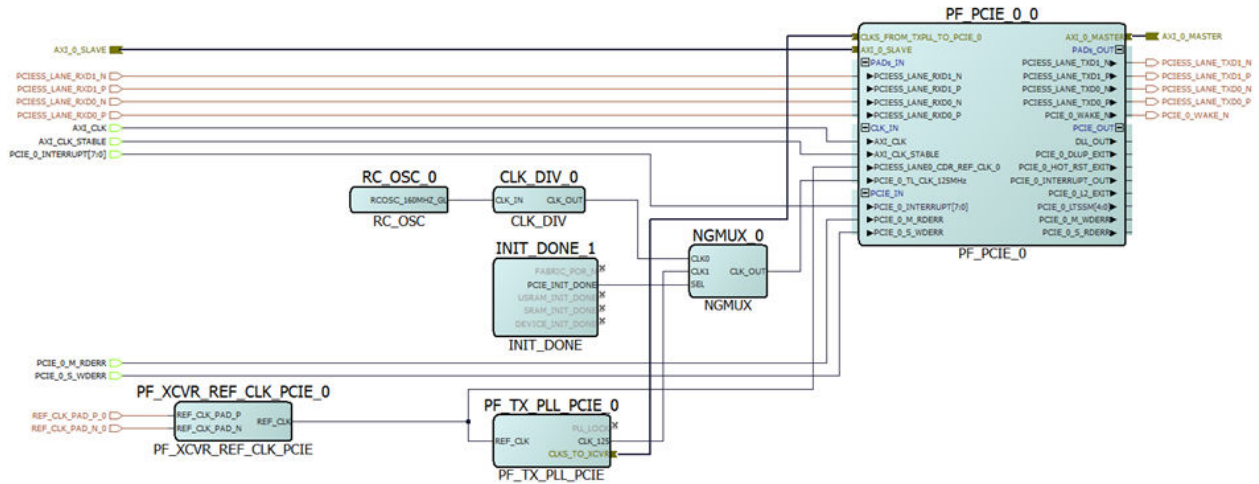

The following table lists the key connections of the SmartDesign PCIe example.

Table 3-8. Key Connections of SmartDesign

Source	Destination
PF_XCVR_REF_CLK_PCIE_0:REF_CLK	PF_TX_PLL_PCIE_0:REFCLK
	PF_PCIE_0_0:PCIESS_LANE0_CDR_REF_CLK_0
PF_TX_PLL_PCIE_0:CLKS_TO_XCVR	PF_PCIE_0_0:CLKS_FROM_TXPLL_TO_PCIE_0
PF_TX_PLL_PCIE_0:CLK_125	PF_PCIE_0_0:PCIE_0_TL_CLK_125MHz

**Note:** For information about how to demonstrate the high-speed data transfer capability of PolarFire FPGA using the hardened PCIe EndPoint, Soft DDR3, and DDR4 controller IP, see [PolarFire FPGA PCIe EndPoint DDR3L DDR4 Memory Controller Data Plane](#).

**Note:** For information about Root Port capabilities of the PolarFire FPGA PCIe controller using Mi-V soft processor, see [PolarFire FPGA PCIe Root Port Application Note \(Earlier DG0802\)](#).

**Note:** For information about PolarFire SoC PCIe Root Port Linux reference design, see [GitHub](#).

### 3.2.1. Using PERSTn When PCIe is Configured as a Root Port [\(Ask a Question\)](#)

PERSTn is a fundamental reset signal defined in both PCI Express Base Specification and PCI Express Card Electromechanical Specification. Root port issues this reset signal through PCIe slots to reset the entire PCIe fabric hierarchy. The APB Master can assert PCIe PERSTn signal through PCIe APB register space. When the host is power cycled, the PERSTn signal is asserted by the PCIe\_INIT\_MONITOR until the PCIe controller in the Root port is initialized.

The following figure shows the PCIe configurator when PCIe is configured as a PCIe Root port.

Figure 3-10. PCIe Configurator When PCIe is Configured as a PCIe Root Port

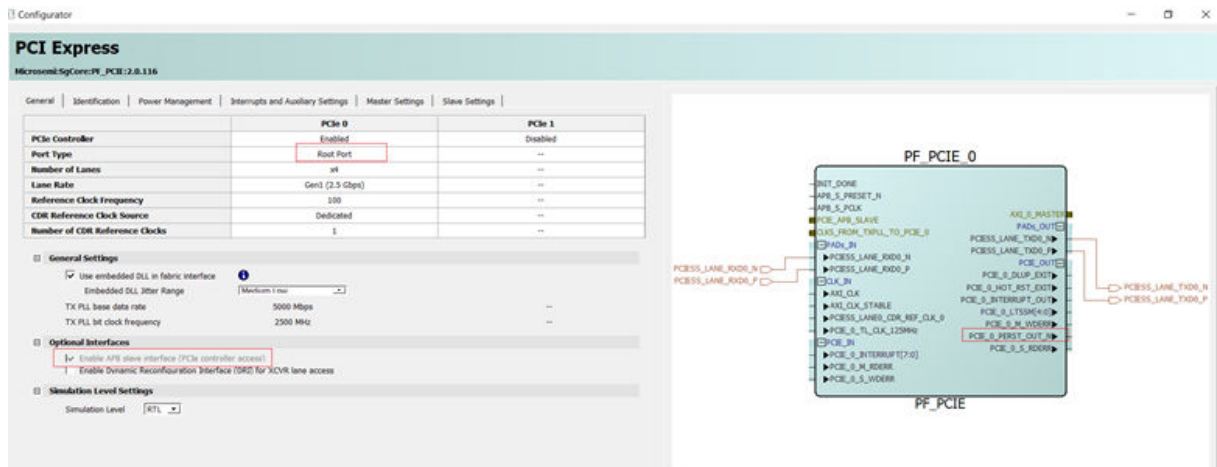

The following figure shows the example of PCIe interface with the PERSTn signal.

Figure 3-11. Complete PCIe Interface Example with PERSTn Signal

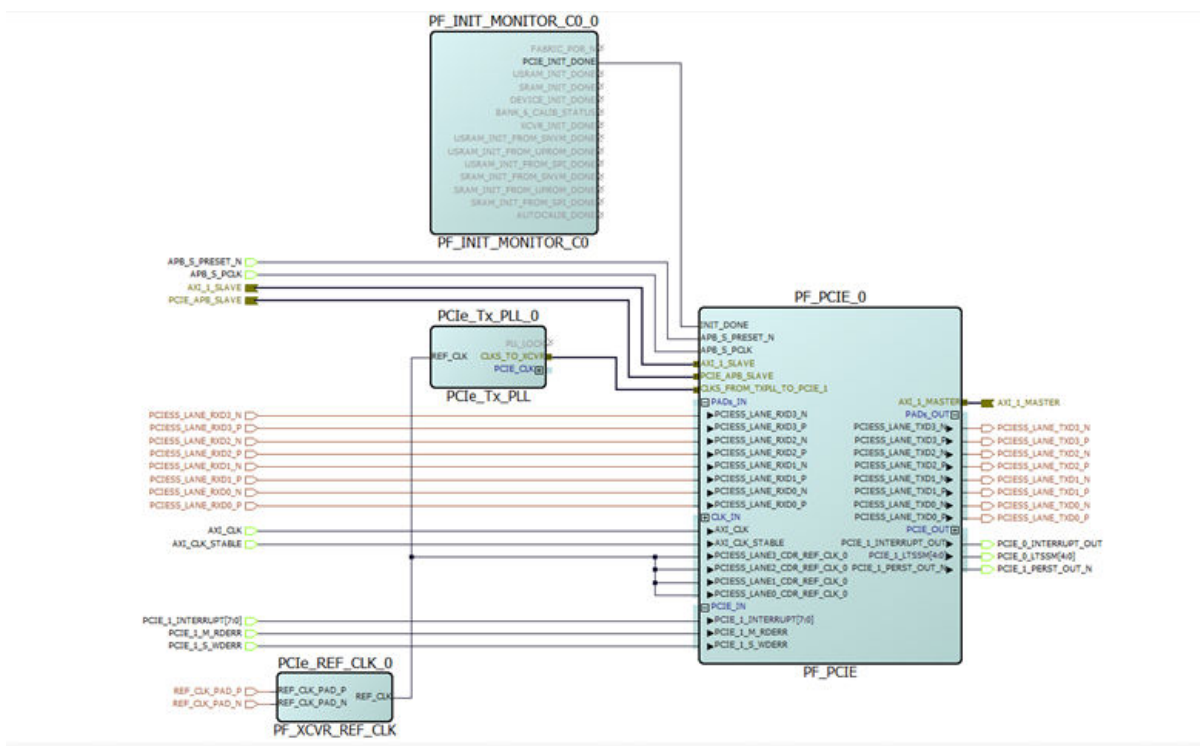

### 3.3. Design Constraints [\(Ask a Question\)](#)

No physical design constraints (PDC) are required for PCIe. Constraints are required for PF\_TXPLL and PF\_XCVR\_REF\_CLK. The Libero software automatically places the PCISS blocks. The PCISS overlays the related transceiver quad 0 lanes. Therefore, when only PCIe 0 is used, it can be used as a x1 or x2 link.

Timing constraints are automatically generated by Libero SoC.

**Note:** Do not add user-supplied clock constraint if the paths are internal to the core.

### 3.4. PCIe Simulation [\(Ask a Question\)](#)

The PCIe supports two simulation modes:

- Bus functional model (BFM)
- Full register-transfer level (RTL) model



**Important:** The PCIe simulation model does not support jitter.

---

#### 3.4.1. Bus Functional Model [\(Ask a Question\)](#)

The PCIe is simulated using the bus functional model (BFM) for the PCI ESS. In this simulation mode, data transfer does not go off-chip. In the PCIe BFM simulation mode, the user can transmit/receive data from/to the fabric using the AXI4 of the PCI ESS. The BFM simulation mode is selected from the Libero PCI ESS configurator GUI. Libero generates the required files for BFM simulation.

The PCIe simulation mode uses the BFM commands to emulate the data that is transferred through the PCI ESS block across the AXI4 bus interface to the fabric. The physical layer of the PCIe protocol is not implemented in this simulation mode. This mode is intended to validate the fabric interfaces to the PCI ESS block, and the physical interface of the XCVR PMA block remains inactive.

The AXI4 bus master in the PCIe BFM simulation mode enables emulating 64-bit AXI master transactions. Libero SoC generates user-customizable BFM files that instruct the model to start transactions to the fabric. The BFM allows the user to use a text file to issue the transactions from the PCIe AXI master interface to the fabric, to exercise the design. The user must include BFM instructions in the `<project>/simulation/PCIE_<0:1>_user.bfm` file. The BFM model interprets these instructions and initiates AXI transactions in sequence. The `PCIE_init.bfm` model is not user-editable.

The AXI bus slave available in the BFM\_P PCIe simulation mode provides a 64-bit slave interface for fabric communication. The user can interact with the slave by initiating write and read bus transactions using the appropriate bus master. The slave acts as a memory model, so whatever is written to the slave can be read back from the same address.

The BFM commands used in the PCI ESS BFM files are similar to the BFM commands used by the bus masters.

**Note:** Simulation of APB interface is not supported in the BFM mode.

The following figure shows the PCI ESS BFM structure.

Figure 3-12. PCI ESS BFM Structure

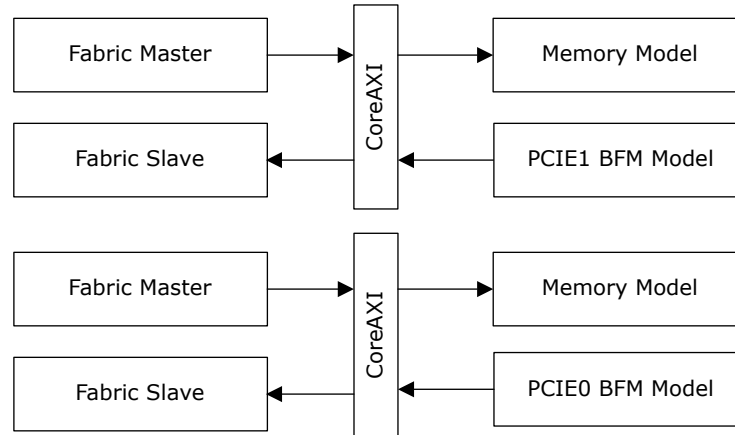

**Note:** There are additional BFM commands that are only used for the PCIe AXI BFM simulation, to emulate 64-bit AXI transactions.

The command, `write64 w <base_address> <base_address_offset> <32-bit MSB> <32-bit LSB>`, makes the bus master start a 64-bit write transaction on the external bus for a slave with address given by the `<base_address>` and `<base_address_offset>`, using the data generated by `<32-bit MSB>` and `<32-bit LSB >`.

For example: `write64 w 0x00000000 0x0 0xA0A1A2A3 0xB0B1B2B3;`

The command, `readcheck64 w <base_address> <base_address_offset> <32-bit MSB> <32-bit LSB>`, makes the bus master start a 64-bit read transaction for the address given by the `<base_address>` and `<base_address_offset>`. It compares the 64-bit read data to the data.

The command `setup 0x8 <source address> <destination address>` is used to set source and destination address for DMA.

The command `setup 0xA <data>` is used to set DMA data source.

`<data> =0 ==>` Data increment by 1 starting from 0x1

`<data> =1 ==>` Random data

`<data> =2 ==>` Data from DMADATA.vec file

For example, `setup 0xA 0x2 data_in.vec`. In this command, DMA data source is `data_in.vec` file.

The command `setup 0x9 <DMA_Length> <Control>` is used for DMA control.

set control bit0 to '1' => start DMA

set control bit1 to '1' => sets transfer from PCIe domain to Fabric domain

set control bit2 to '1' => sets transfer from Fabric domain to PCIe domain

When control = 0x3, BFM starts DMA transfer from PCIe to Fabric and when control = 0x5, BFM starts DMA transfers from Fabric to PCIe.

### 3.4.2. Full Register-transfer Level (RTL) Model [\(Ask a Question\)](#)

In this simulation mode, the register-transfer level (RTL) model of the PCI ESS is used, and the entire data path through the PCI ESS is exercised. It requires a third-party verification IP (VIP) model for PCIe. The user is responsible for the VIP model for the PCIe.

When using VIP models, ensure the following:

- Verification IP must be configured properly.
  - BFM type: indicates type of BFM (0 – Root port and 1 – End point).
  - Number of lanes: indicates number of connected lanes.
  - I/O size: specifies the size of internal I/O space. The values range from 12 to 24.
  - MEM32\_SIZE: specifies the size of internal 32-bit addressing memory space. The values range from 12 to 24.
  - MEM64\_SIZE: specifies the size of internal 64-bit addressing memory space. The values range from 12 to 24.
  - PCLK: PIPE clock frequency depends on the signaling rate and PIPE interface width configuration.
- The receiver pin for XCVR must not be in an unused state. The following example code snippet is used in the testbench to prevent the transmitter pin from going into an unused state.

```
rxp[i] <= (tx_1b[i]===1'bX || tx_1b[i]===1'bZ) ? 1'b0 : tx_1b[i];
```

```
rxn[i] <= (tx_1b[i]===1'bX || tx_1b[i]===1'bZ) ? 1'b0 : ~tx_1b[i];
```

- The receiver pin for VIP model must not be in an unused state. The following example code snippet is used in the testbench to prevent the transmitter pin from going into an unused state.

```
rx_1b[i] <= (txp[i]==txn[i] || txp[i]===1'bX) ? 1'bZ : txp[i];
```

Where,

- i – Number of BFM lanes
- txp and txn – Transmitter pins from XCVR
- rxp and rxn – Receiver pins from XCVR
- tx\_1b – Transmitter pin from VIP model
- rx\_1b – Receiver pin from VIP model

### 3.5. PCIe Subsystem Performance [\(Ask a Question\)](#)

Throughput is the amount of data transferred over a given period of time. [Table 3-9](#) and [Table 3-10](#) lists the throughput values of PCIe AXI master interface and AXI slave interface.

For throughput details of the PCIe subsystem in end point and root port configurations, see the following documents:

- [PolarFire FPGA PCIe EndPoint DDR3L DDR4 Memory Controller Data Plane](#)
- [PolarFire FPGA PCIe Root Port Application Note](#)

#### 3.5.1. PCIe AXI Master IF Throughput [\(Ask a Question\)](#)

Throughput calculation is carried out at 250 MHz AXI CLK using built-in DMA (64 KB of DMA size), maximum payload of 128 Bytes. The built-in DMA initiates 32-bit AXI burst length transactions on AXI Master IF. When using the built-in DMA, eight PCIe outstanding transactions are supported.

**Table 3-9.** PCIe AXI Master IF Throughput

Link Width	Link Speed	PC to LSRAM (Memory Read from PC)		LSRAM to PC (Memory Write to PC)		Maximum Theoretical Throughput (MBps)
		Maximum Throughput (MBps)	% of Theoretical Throughput	Throughput (MBps)	% of Theoretical Throughput	
x1	Gen1	206	82.4	226	90.4	250
	Gen2	411	82.2	453	90.6	500

**Table 3-9.** PCIe AXI Master IF Throughput (continued)

Link Width	Link Speed	PC to LSRAM (Memory Read from PC)		LSRAM to PC (Memory Write to PC)		Maximum Theoretical Throughput (MBps)
		Maximum Throughput (MBps)	% of Theoretical Throughput	Throughput (MBps)	% of Theoretical Throughput	
x2	Gen1	410	82	439	87.8	500
	Gen2	814	81.4	875	87.5	1000
x4	Gen1	811	81.1	830	83	1000
	Gen2	1181	59.05	1508	75.4	2000

### 3.5.2. PCIe AXI Slave IF Throughput [\(Ask a Question\)](#)

Throughput calculation is carried out at 250 MHz AXI CLK using fabric AXI DMA (64 KB of DMA size), maximum payload of 128 Bytes. The fabric AXI DMA 256-beat AXI burst length transactions on AXI slave IF. When using AXI slave IF, four PCIe outstanding transactions are supported.

**Table 3-10.** PCIe AXI Slave IF Throughput

Link Width	Link Speed	PC to LSRAM (Memory Read from PC)		LSRAM to PC (Memory Write to PC)		Maximum Theoretical Throughput (MBps)
		Maximum Throughput (MBps)	% of Theoretical Throughput	Throughput (MBps)	% of Theoretical Throughput	
x1	Gen1	204	81.6	226	90.4	250
	Gen2	411	82.2	453	90.6	500
x2	Gen1	397	79.4	440	88	500
	Gen2	599	59.9	877	87.7	1000
x4	Gen1	483	48.3	831	83.1	1000
	Gen2	665	33.25	1646	82.3	2000

PCIe Throughput depends on the following factors:

- PCIe uses 8b10b encoding, which causes 20% reductions in throughput.
- The maximum PCIe read throughput also depends on the supported PCIe outstanding transactions and Round-trip time (RTT).
- Maximum effective bandwidth is the rate at which valuable data is transferred at a particular point. It does not include transaction overhead, such as headers, sequence numbers, CRCs, ECRCs, and other packets like DLLPs and SKIP advanced sets.  
Maximum Effective Bandwidth = data/(data + overhead)

The following table lists the relation between maximum transaction payload size and efficiency. Increasing the transaction payload size (increasing the burst length) also improves throughput.

**Table 3-11.** Relation Between Maximum Transaction Payload Size and Efficiency

Maximum Transaction Payload Size (Byte)	Efficiency
128	86%
256	92%

### 3.6. Initialization [\(Ask a Question\)](#)

When the device powers up, some registers contained in the PCIESS are automatically initialized using data stored in the non-volatile storage of the device. The values associated with these registers are set either using flash bits or based on fixed values. Some registers are also loaded at power-up through an initialization mechanism that is programmed into devices implementing PCIESS blocks. This initialization is autonomously generated by Libero and is transparent.

For information about initialization, see [PolarFire Family Device Power-Up and Resets User Guide](#).

## 4. Configuration Registers (Ask a Question)

The PCIe settings should be reconfigured through 32-bit wide configuration space registers, listed as follows:

- Information registers, which provide device, system, and bridge identification information
- Bridge configuration registers, which enable configuration of the bridge functionality. These include:
  - Read-only registers that report control and status registers to the AXI4 bus
  - Bridge settings that must be configured at power-up, such as local interrupt mapping
- Control/status registers, which are used by the AXI4 bus to control bridge behavior during an operation
- Power management registers, which configure the power management capabilities of the bridge
- Address mapping registers, which provide address mapping for AXI4 master and slave windows used for address translation
- Root port and Endpoint interrupt registers
- For Root port, user should use the APB register space to toggle or control the PERSTn output port
- PCIe control and status registers, which enable the local processor to check the PCIe interface status. These read-only registers enable the local processor to detect the initialization of the bridge's PCIe interface and monitor PCI link events.

Some registers are hardwired to a fixed value within the embedded PCIESS block

In Endpoint mode, **PCIESS** core issues interrupts to the Host processor (over the PCIe domain) for the following events:

- DMA transfer end or error
- Address Translation doorbell or error
- Local interrupts (through local\_interrupt\_in[7:0] input port by local processor)

When one of the preceding events occurs, the source of the interrupt is reported in the ISTATUS\_HOST register. The Host processor masks or enables each interrupt source independently by setting or clearing the corresponding bit in the IMASK\_HOST register. If one or more ISTATUS\_HOST interrupt sources are active and not masked by IMASK\_HOST, the Bridge IP core issues an interrupt towards the Host Processor (over the PCIe domain). The interrupt is sent using Message Signaled Interrupt (MSI) if the PCIe host processor has enabled MSI, otherwise INT messages are used.

**IMASK\_HOST - Host Processor Interrupt Mask** (For EndPoint only): Integration does not hardwire this register by Core Constants so it is read or write and its default value after reset is 32'h0. Setting a bit enables the associated interrupt source and clearing a bit masks the interrupt source.

**ISTATUS\_HOST**: This is a read/write/clear register; the register's bits are automatically set when the corresponding interrupt source is activated. Each source is independent, and thus multiple sources may be active simultaneously. The host processor monitors and clears status bits: writing 1 clears a bit, writing 0 has no effect.

The ISTATUS\_HOST register is composed of the following bits for various interrupt sources:

- DMA\_END Bit [7:0]: reports that a DMA transfer is ended. Bit number "i" corresponds to DMA Engine number "i"
- DMA\_ERROR Bit [15:8]: reports that an error occurred during a DMA transfer. Bit number "i" corresponds to DMA Engine number "i".

- A\_ATR\_EVT Bit [19:16]: reports AXI Address Translation events (see ISTATUS\_LOCAL for the same definition)
- P\_ATR\_EVT Bit [23:20]: reports PCIe Address Translation events (see ISTATUS\_LOCAL for the same definition)
- INT\_REQUEST Bit [31:24]: reports interrupt requests from the local processor (in this endpoint) to the Host Processor

When the PCIe is in Endpoint Mode, the local processor can drive up to eight interrupt sources high by generating a pulse (high) on the local\_interrupt\_in [7:0] input port and can drive those interrupt sources low by writing 1 to corresponding bits in this field.

For information about Configuration registers, see respective [PolarFire Device Register Map](#) or [PolarFire SoC Register Map](#).

## 5. PCIe Configuration Space [\(Ask a Question\)](#)

The following tables list the layout of the PCI express configuration space and provides the mapping for each register in the space.

**Table 5-1. PCI Configuration Space**

Offset	Description
0x00 to 0x03C	Type0 (endpoint) or Type1 (Root port/Bridge/Switch) Standard PCI configuration header
0x040 to 0x07C	Reserved
0x080 to 0x0B8	PCI Express Capability
0x0BC to 0x0CC	Reserved
0x0DC	Reserved
0x0E0 to 0x0F4	MSI Capability
0x0F8 to 0x0FC	PCI Power Management Capability

**Table 5-2. PCI Express Capability Structure**

Byte Offset	Bit Number			
	31:24	23:16	15:8	7:0
0x080	Capability Register		Next capability Pointer	Capability ID
0x084	Device capabilities			
0x088	Device status		Device control	
0x08C	Link capabilities			
0x090	Link status		Link control	
0x094	Slot capabilities			
0x098	Slot status		Slot control	
0x09C	Root capabilities		Root control	
0x0A0	Root Status			
0x0A4	Device capabilities 2			
0x0A8	Device status 2		Device control 2	
0x0AC	Link capabilities 2			
0x0B0	Link status 2		Link control 2	
0x0B4	Slot capabilities 2			
0x0B8	Slot status 2		Slot control 2	

**Table 5-3. MSI Capability Structure**

Byte Offset	Bit Number			
	31:24	23:16	15:8	7:0
0x0E0	Message Control		Next pointer	Capability ID
0x0E4	Message Address			
0x0E8	Message Upper Address			
0x0EC				Message Data

**Table 5-4. Power management Capability Structure**

Byte Offset	Bit Number			
	31:24	23:16	15:8	7:0
0x0F8	Power management capabilities		Next item pointer	Capability ID
0x0FC	Data	PMCSR_BSE bridge support extensions	Power management control and status registers	

**Table 5-5.** PCI Express Extended Configuration Space

Offset	Description
0x100 to 0x104	Vendor-specific capability with VSECID = 1556h; RevID = 1h
0x108 to 0x10C	Latency Tolerance Reporting capability
0x200 to 0x234	Advanced Error Reporting capability

**Table 5-6.** Vendor Specific Extended Capability Structure

Byte Offset	Bit Number
	31:24      23:16      15:8      7:0
0x100	Vendor-Specific Extended Capability Header
0x104	Vendor-Specific Header

**Table 5-7.** Latency Tolerance Reporting Capability Structure

Byte Offset	Bit Number
	31:24      23:16      15:8      7:0
0x108	PCI Express Extended Capability Header
0x10C	Max No-Snoop Latency Register      Max Snoop Latency Register

**Table 5-8.** Advanced Error Reporting Capability Structure

Byte Offset	Bit Number
	31:24      23:16      15:8      7:0
0x200	PCI Express Enhanced Capability Header
0x204	Uncorrectable Error Status Register
0x208	Uncorrectable Error Mask Register
0x20C	Uncorrectable Error Severity Register
0x210	Correctable Error Status Register
0x214	Correctable Error Mask Register
0x218	Advanced Error Capabilities and Control Register
0x21C	Header Log Register
0x22C	Root Error Command
0x230	Root Error Status
0x234	Error Source Identification Register

## 6. Board Design Recommendations [\(Ask a Question\)](#)

This chapter discusses board-level implementation details of a PCIe design using the PolarFire family of devices. Optimal performance requires understanding the functionality of the device pins and properly addressing issues such as device interfacing, protocol specifications, and signal integrity.

For more information, see respective [PolarFire FPGA Board Design User Guide](#), [RT PolarFire Board Design User Guide](#), or [PolarFire SoC FPGA Board Design Guidelines User Guide](#).

Various specifications from PCI-SIG apply depending on the form factor of the design. This chapter focuses on a subset of these specifications centered on chip-to-chip and add-in card implementations.

For more information, see the [PCI Express Base Specification, Revision 2.0](#) and [PCI Express Card Electromechanical Specification \(CEM\) Revision 2.0](#) from PCI-SIG.

### 6.1. AC-Coupling [\(Ask a Question\)](#)

PCIe electrical signals require a 75 - 200 nF AC-coupling capacitor between the transmitter and receiver. All transmitters are AC-coupled, either within the media or within the transmitting component itself. If located within the media, the AC-coupling capacitors are placed close to the transmitter. The AC-coupling capacitor is used in conjunction with internal termination for PCIe link detection.

### 6.2. Lane Reversal [\(Ask a Question\)](#)

The PCI ESS supports lane reversal when required, allowing the PCIe physical I/O to be reversed with the block's logical lanes for a more flexible PCB layout. Lane reversal functionality is incorporated into the PCI ESS to be layout-agnostic with respect to lane ordering and lane polarity. Using lane reversal eases routing congestion on the PCB, leading to a cleaner interface between the PCIe host and the endpoint or root port.

### 6.3. Polarity Inversion [\(Ask a Question\)](#)

The transceiver block with PCI ESS supports differential polarity inversion. Receiver polarity is automatically detected by the PCI ESS during link training, as defined in the PCIe specification. The differential data received by the transceiver RX are reversed if RXP and RXN differential traces are swapped on the PCB, accidentally. The transceiver RX inversion allows within the PCI ESS to offset the reversed polarity of a serial differential pair.

### 6.4. PCIe Power-Up [\(Ask a Question\)](#)

The PCIe specification provides timing requirements for power-up. The PCIe connector specification specifies that the fundamental reset (PERST\_N) be de-asserted at a minimum of 100 ms from the point of stable power. The PCIe PERST\_N signal release time (known as PCIe timing parameter TPVPERL) of 100 ms is used for the PCIe card electro-mechanical specification for add-in cards.

The semi-autonomous nature of the PCI ESS in a device allows the device to quickly move from power-up to link detect. The transceiver initially terminates to 50 k $\Omega$  for hot-swap protection but quickly returns to 100  $\Omega$  termination so that link detection operates within the PCIe specifications. When the device is detected by the root, it proceeds to the polling state of the LTSSM. The link then cycles through the remaining LTSSM states. In cases where the root point and the endpoint power-up separately, the PERST\_N signal must be used to handshake the link startups.

PERST\_N is a system-level requirement for PCIe system as defined by the PCIe specification. The PERST\_N pin resets the PL, TL domains, but it does not reach the AXI, bridge logic, or bridge map registers in the PCI ESS core within the device.

### 6.4.1. PCIe Edge Connector [\(Ask a Question\)](#)

PCIe is a point-to-point serial differential low-voltage interconnect supporting up to four channels. Each lane consists of two pairs of differential signals: transmit pair, receive pair, XCVR\_x\_TXy\_P/N, and XCVR\_x\_RXy\_P/N. Each signal has a 2.5 GHz embedded clock.

The following figure shows the connectivity between the transceiver interface and the PCIe edge connector.

**Figure 6-1.** Connectivity Between XCVR Interface and PCIe Edge Connector

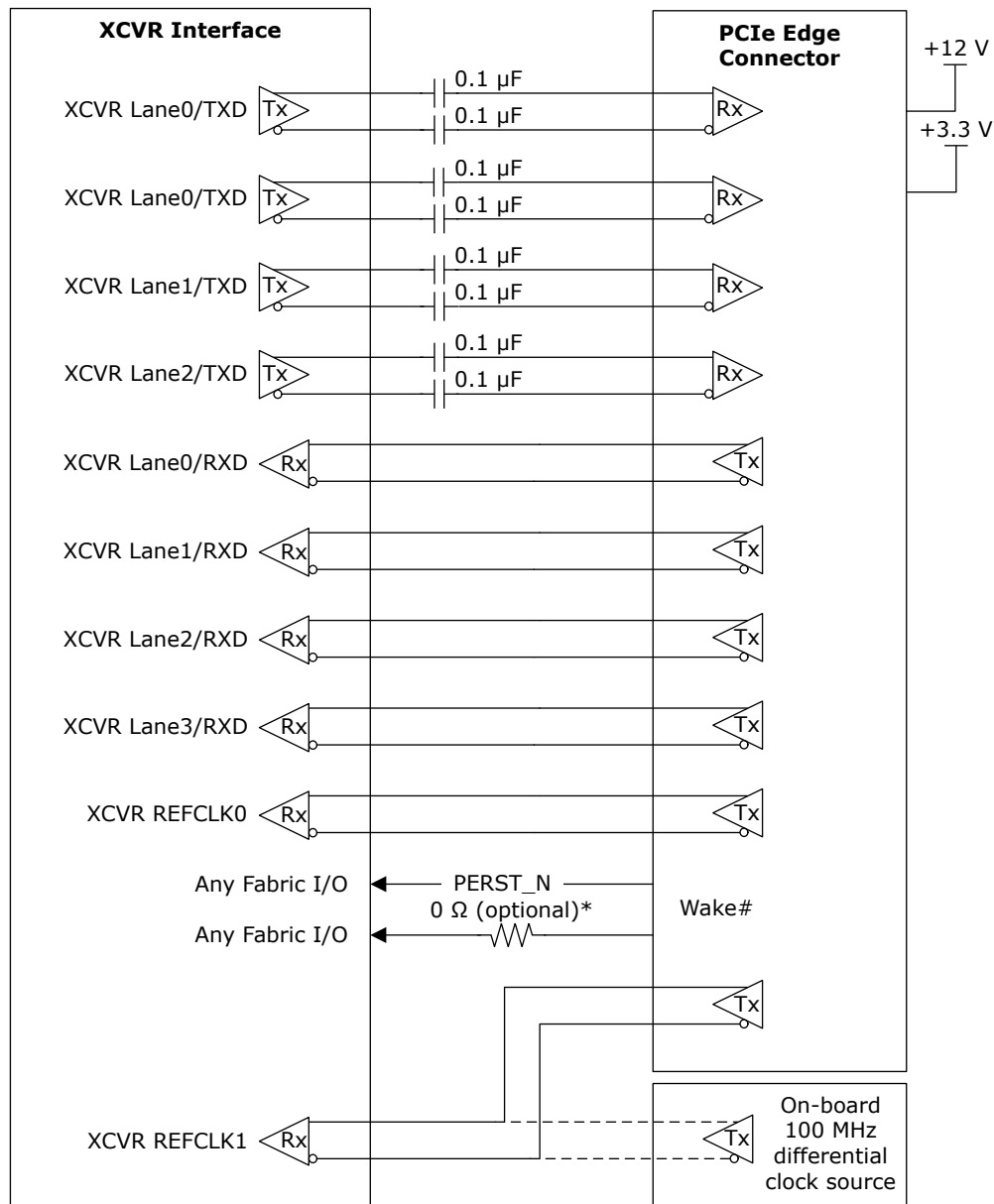

**Note:** Between the fabric I/O and the host may require additional components to match 3.3 V levels.

## 7. PCI-SIG TxPLL Electrical Compliance Test [\(Ask a Question\)](#)

Due to variations in board topologies, it might be necessary to adjust the Tx amplitude characteristics to ensure compliance with electrical requirements of Peripheral Component Interconnect Special Interest Group (PCI-SIG). The following fields, of the SER\_DRV\_CTRL\_M# register, are available to provide this control:

- TXDRVTRIM\_FS\_#P#B\_M#
- TXDRVTRIM\_HS\_0DB\_M#

Where:

- #P#B indicates the requested amount of de-emphasis
- M# indicates the requested TxSwing value

These register fields consist of two 3-bit controls:

- The most significant 3 bits control the cursor amplitude. Increasing this value by 1 (for example, from 4 to 5) increases the amplitude and height of the inner eye by 20 mV, approximately. Decreasing this value by 1 has the opposite effect.
- The least significant 3 bits control the post-cursor amplitude. Increasing this value by 1 (for example, from 4 to 5) increases the amplitude by approximately 20 mV and decreases the height of the inner eye by the same amount. Decreasing the value by 1 has the opposite effect.

To pass the PCISIG's Tx PLL bandwidth electrical compliance test on the ICICLE kit, the following settings were used:

- TxMARGIN was set to 0x0 and TXSWING was set to 0x1.
- Modified the register field TXDRVTRIM\_FS\_3P5DB\_M0 from 0x0A to 0x00. This lowered the total amplitude by 75 mV.
- Modified the register field TXDRVTRIM\_FS\_6P0DB\_M0 from 0x24 to 0x13.

## 8. Revision History [\(Ask a Question\)](#)

The revision history table describes the changes that were implemented in the document. The changes are listed by revision, starting with the most current publication.

**Table 8-1.** Revision History

Revision	Date	Description
J	05/2025	The following is a summary of changes made in the revision. <ul style="list-style-type: none"> <li>Changed the width of PCIESS_AXI_#_M_ARSIZE, PCIESS_AXI_#_M_AWSIZE, PCIESS_AXI_#_S_ARSIZE, and PCIESS_AXI_#_S_AWSIZE ports to [2:0] in <a href="#">PCIESS Port List</a>.</li> <li>Updated the <a href="#">note</a> under <a href="#">Table 3-2</a>, in the section <a href="#">PCIe Configurator</a>, by adding the frequency range supported by the PCIe APB_S_CLK.</li> </ul>
H	05/2024	The following is a summary of changes made in the revision. <ul style="list-style-type: none"> <li>Replaced XpressRICH3-AXI with PCIESS in the <a href="#">Configuration Registers</a> section</li> </ul>
G	03/2024	The following is a summary of changes made in the revision. <ul style="list-style-type: none"> <li>Added <a href="#">PCI-SIG TxPLL Electrical Compliance Test</a> which describes the registers that can be used to pass the compliance test.</li> </ul>
F	01/2024	The following is a summary of changes made in the revision. <ul style="list-style-type: none"> <li>De-featured support on PCIe Subsystem memory ECC reporting. See <a href="#">ECC</a>. Removed information about SECEDED. For more information about defeaturing of PCIe SECEDED reporting, see <a href="#">Change Impact Analysis</a>.</li> <li>Updated the descriptions of PCIE_#_M_RDERR, PCIE_#_M_WDERR, PCIE_#_S_RDERR, and PCIE_#_S_WDERR ports. See <a href="#">PCIESS Port List</a>.</li> </ul>
E	09/2023	The following is a summary of changes made in the revision. <ul style="list-style-type: none"> <li>Changed the document title to “PolarFire Family PCI Express” and added support for RT PolarFire throughout the document.</li> <li>Added information about PCIe to AXI4 outstanding transaction. See <a href="#">AXI Master Write Transactions</a>, <a href="#">AXI Master Read Transactions</a>, and <a href="#">AXI Slave Read Transactions</a>.</li> <li>Added information about debug recommendations when LTSSM does not reach L0. See <a href="#">Low-Power States</a>.</li> <li>Updated information about <a href="#">PCIe MSS</a>.</li> <li>Added links to <a href="#">PolarFire FPGA PCIe Endpoint DDR3L DDR4 Memory Controller Data Plane</a> and <a href="#">PolarFire FPGA PCIe Root Port Application Note</a> in <a href="#">PCIe Subsystem Performance</a> for throughput details in the end point and root port configurations.</li> <li>Added information about mapping of interrupt[7:0]. See <a href="#">Configuration Registers</a>.</li> <li>Updated information about power management, interrupts, and auxiliary settings. See <a href="#">PCIe Configurator</a>.</li> </ul>
D	12/2022	The following is a summary of changes made in the revision. <ul style="list-style-type: none"> <li>Updated the GitHub links in the document.</li> <li>Added a note in <a href="#">PCIe Simulation</a> section.</li> <li>Updated information about interrupts. See <a href="#">PCIe Configurator</a>.</li> </ul>
C	04/2022	Added information about PERSTn signal when PCIe is configured as Root port. See <a href="#">Using PERSTn When PCIe is Configured as a Root Port</a> .
B	01/2022	The following is a summary of changes made in the revision. <ul style="list-style-type: none"> <li>Information about <a href="#">Figure 1-8</a> was updated.</li> <li>Information about low-power operation state L2/P2 was removed as it is defeatured.</li> <li>The revision history tables of both the user guides are retained here for the future reference. For information, see <a href="#">Table 8-2</a> and <a href="#">Table 8-3</a>.</li> </ul>

**Table 8-1. Revision History (continued)**

Revision	Date	Description
A	08/2021	The first publication of the document. This user guide was created by merging the following documents: <ul style="list-style-type: none"> <li>UG0685: PolarFire FPGA PCI Express User Guide</li> <li>UG0920: PolarFire SoC FPGA PCI Express User Guide</li> </ul>

The following revision history table describes the changes that were implemented in the UG0685: PolarFire FPGA PCI Express User Guide document. The changes are listed by revision.

**Note:** UG0685: PolarFire FPGA PCI Express User Guide document is now obsolete and the information in the document has been migrated to PolarFire Family PCI Express User Guide.

**Table 8-2. Revision History of UG0685: PolarFire FPGA PCI Express User Guide**

Revision	Date	Description
Revision 10.0	4/21	The following is a summary of the changes in the revision. <ul style="list-style-type: none"> <li>Information about PCIE_#_INTERUPT[7:0] port description was updated. See PCI ESS Port List table.</li> <li>Information about Bus Functional Model was updated.</li> <li>Information about MSI Capability Structure was updated. See MSI Capability Structure table.</li> <li>Information about PERST_N signal was added. See PCIe Power-Up.</li> <li>Reference to information about how to debug PCIe was added. See Libero Configurators.</li> </ul>
Revision 9.0	9/20	The following is a summary of the changes in the revision. <ul style="list-style-type: none"> <li>Information about signal width of AWBURST, ARBURST, AWID, and AWLEN was updated. See PCI ESS Port List table.</li> <li>Information about using of embedded DLL in fabric interface was updated. See PCIe General Settings table.</li> </ul>
Revision 8.0	5/20	The following is a summary of the changes in the revision. <ul style="list-style-type: none"> <li>Information about SEC_ERROR_EVENT_CNT and DED_ERROR_EVENT_CNT counter registers was updated. See ECC.</li> <li>Information about unused PCIe lanes were updated. See Legal Combinations of PCIe and XCVR Protocols figure.</li> <li>Information about DLUP_EXIT signal was updated. See PCI ESS Port List table.</li> </ul>
Revision 7.0	4/19	The following is a summary of the changes in the revision. <ul style="list-style-type: none"> <li>Structural changes were made throughout the document.</li> <li>Information about PCIe general settings was updated.</li> <li>Information about PCI ESS_AXI_#_M_BRESP[1:0] was updated. See PCI ESS Port List table.</li> <li>Information about PCIE_#_M_RDERR and PCIE_#_M_WDERR was updated. See PCI ESS Port List table.</li> <li>Information about PCIE_#_INTERUPT[7:0] port was updated. See PCI ESS Port List table.</li> </ul>
Revision 6.0	10/18	The following is a summary of the changes in the revision. <ul style="list-style-type: none"> <li>Information about port description was updated. See PCI ESS Port List table.</li> <li>Information about DMA source and destination address register descriptions was updated. See Scatter-Gather DMA Descriptors table.</li> <li>Information about user-supplied clock constraint was added. See Design Constraints.</li> <li>Information about Transmitter was updated.</li> <li>Information about how to enable ECC after PCIe enumeration was added. See ECC.</li> </ul>
Revision 5.0	7/18	The document was updated for Libero SoC PolarFire v2.2 release.

**Table 8-2.** Revision History of UG0685: PolarFire FPGA PCI Express User Guide (continued)

Revision	Date	Description
Revision 4.0	4/18	<p>The following is a summary of the changes in the revision.</p> <ul style="list-style-type: none"> <li>Information about AXI split transactions was added. See Conversion Between PCIe and AXI Transactions.</li> <li>Information about AXI limitation was added. See AXI4 Limitations.</li> <li>Information about AXI Master and Slave Throughput was added. See PCIe AXI Master IF Throughput and PCIe AXI Slave IF Throughput.</li> <li>Information about wake signals was updated. See PCIe Interrupts and Auxiliary Settings table.</li> <li>Information about PCIe translation address was updated. See PCIe Master Settings and PCIe Slave Settings tables.</li> </ul>
Revision 3.0	11/17	<p>The following is a summary of the changes in the revision.</p> <ul style="list-style-type: none"> <li>Information about PCIe Subsystem memory buffers was added. See ECC.</li> <li>Information about PCIE_#_TL_CLK_125MHz port name was updated. See PCIESS Port List table.</li> <li>Information about register content of the PCIe configuration space was added. See PCIe Configuration Space.</li> <li>Updated Configuration Registers chapter.</li> <li>A note about PCIe BFM simulation model was added in PCIe Simulation section.</li> </ul>
Revision 2.0	6/17	<p>The following is a summary of the changes in the revision.</p> <ul style="list-style-type: none"> <li>Information about how to use VIP models was added. See PCIe Simulation.</li> <li>Information about DMA Descriptors was added. See DMA Transfers.</li> <li>Updated PCIe Configurator screen shots.</li> </ul>
Revision 1.0	2/17	The first publication of UG0685: PolarFire FPGA PCI Express User Guide

The following revision history table describes the changes that were implemented in the UG0920: PolarFire SoC FPGA PCI Express User Guide document. The changes are listed by revision.

**Note:** UG0920: PolarFire SoC FPGA PCI Express User Guide document is now obsolete and the information in the document has been migrated to PolarFire Family PCI Express User Guide.

**Table 8-3.** Revision History of UG0920: PolarFire SoC FPGA PCI Express User Guide

Revision	Date	Description
Revision 3.0	5/21	<p>The following is a summary of the changes in the revision.</p> <ul style="list-style-type: none"> <li>Information about PCIE_#_INTERRUPT[7:0] port description was updated. See PCIESS Port List table.</li> <li>Information about Bus Functional Model was updated.</li> <li>Information about MSI Capability Structure was updated. See MSI Capability Structure table.</li> <li>Information about PERST_N signal was added. See PCIe Power-Up.</li> <li>Reference to information about how to debug PCIe was added. See Libero Configurators.</li> </ul>
Revision 2.0	9/20	<p>The following is a summary of the changes in the revision.</p> <ul style="list-style-type: none"> <li>Information about signal width of AWBURST, ARBURST, AWID, and AWLEN was updated. See PCIESS Port List table.</li> <li>Information about using of embedded DLL in fabric interface was updated. See PCIe General Settings table.</li> </ul>
Revision 1.0	5/20	The first publication of UG0920: PolarFire SoC FPGA PCI Express User Guide

## Microchip FPGA Support

Microchip FPGA products group backs its products with various support services, including Customer Service, Customer Technical Support Center, a website, and worldwide sales offices. Customers are suggested to visit Microchip online resources prior to contacting support as it is very likely that their queries have been already answered.

Contact Technical Support Center through the website at [www.microchip.com/support](http://www.microchip.com/support). Mention the FPGA Device Part number, select appropriate case category, and upload design files while creating a technical support case.

Contact Customer Service for non-technical product support, such as product pricing, product upgrades, update information, order status, and authorization.

- From North America, call **800.262.1060**
- From the rest of the world, call **650.318.4460**
- Fax, from anywhere in the world, **650.318.8044**

## Microchip Information

### Trademarks

The “Microchip” name and logo, the “M” logo, and other names, logos, and brands are registered and unregistered trademarks of Microchip Technology Incorporated or its affiliates and/or subsidiaries in the United States and/or other countries (“Microchip Trademarks”). Information regarding Microchip Trademarks can be found at <https://www.microchip.com/en-us/about/legal-information/microchip-trademarks>.

ISBN: 979-8-3371-1159-9

### Legal Notice

This publication and the information herein may be used only with Microchip products, including to design, test, and integrate Microchip products with your application. Use of this information in any other manner violates these terms. Information regarding device applications is provided only for your convenience and may be superseded by updates. It is your responsibility to ensure that your application meets with your specifications. Contact your local Microchip sales office for additional support or, obtain additional support at [www.microchip.com/en-us/support/design-help/client-support-services](http://www.microchip.com/en-us/support/design-help/client-support-services).

THIS INFORMATION IS PROVIDED BY MICROCHIP “AS IS”. MICROCHIP MAKES NO REPRESENTATIONS OR WARRANTIES OF ANY KIND WHETHER EXPRESS OR IMPLIED, WRITTEN OR ORAL, STATUTORY OR OTHERWISE, RELATED TO THE INFORMATION INCLUDING BUT NOT LIMITED TO ANY IMPLIED WARRANTIES OF NON-INFRINGEMENT, MERCHANTABILITY, AND FITNESS FOR A PARTICULAR PURPOSE, OR WARRANTIES RELATED TO ITS CONDITION, QUALITY, OR PERFORMANCE.

IN NO EVENT WILL MICROCHIP BE LIABLE FOR ANY INDIRECT, SPECIAL, PUNITIVE, INCIDENTAL, OR CONSEQUENTIAL LOSS, DAMAGE, COST, OR EXPENSE OF ANY KIND WHATSOEVER RELATED TO THE INFORMATION OR ITS USE, HOWEVER CAUSED, EVEN IF MICROCHIP HAS BEEN ADVISED OF THE POSSIBILITY OR THE DAMAGES ARE FORESEEABLE. TO THE FULLEST EXTENT ALLOWED BY LAW, MICROCHIP’S TOTAL LIABILITY ON ALL CLAIMS IN ANY WAY RELATED TO THE INFORMATION OR ITS USE WILL NOT EXCEED THE AMOUNT OF FEES, IF ANY, THAT YOU HAVE PAID DIRECTLY TO MICROCHIP FOR THE INFORMATION.

Use of Microchip devices in life support and/or safety applications is entirely at the buyer’s risk, and the buyer agrees to defend, indemnify and hold harmless Microchip from any and all damages, claims, suits, or expenses resulting from such use. No licenses are conveyed, implicitly or otherwise, under any Microchip intellectual property rights unless otherwise stated.

## Microchip Devices Code Protection Feature

Note the following details of the code protection feature on Microchip products:

- Microchip products meet the specifications contained in their particular Microchip Data Sheet.
- Microchip believes that its family of products is secure when used in the intended manner, within operating specifications, and under normal conditions.
- Microchip values and aggressively protects its intellectual property rights. Attempts to breach the code protection features of Microchip products are strictly prohibited and may violate the Digital Millennium Copyright Act.
- Neither Microchip nor any other semiconductor manufacturer can guarantee the security of its code. Code protection does not mean that we are guaranteeing the product is “unbreakable”. Code protection is constantly evolving. Microchip is committed to continuously improving the code protection features of our products.