

---

---

## Hardware Design Checklist

---

---

### 1.0 INTRODUCTION

This document provides a hardware design checklist for the Microchip USB7216C. These checklist items should be followed when utilizing the USB7216C in a new design. A summary of these items is provided in [Section 9.0, "Hardware Checklist Summary"](#). Detailed information on these subjects can be found in the corresponding section:

- [Section 2.0, "General Considerations"](#)
- [Section 3.0, "Power and Bypass Capacitance"](#)
- [Section 4.0, "USB Signals and Connections"](#)
- [Section 5.0, "Clock Circuit"](#)
- [Section 6.0, "Power and Startup"](#)
- [Section 7.0, "External SPI Memory"](#)
- [Section 8.0, "Configuration, Straps, and Miscellaneous Interfaces"](#)

### 2.0 GENERAL CONSIDERATIONS

#### 2.1 Required References

At a minimum, the circuit designer should have the following documents on hand:

- *USB7216C Data Sheet* ([www.microchip.com/DS00003143](http://www.microchip.com/DS00003143))
- *USB7216C Errata* ([www.microchip.com/DS80000847](http://www.microchip.com/DS80000847))
- *AN26.2 - Implementation Guidelines for Microchip's USB 2.0 and USB 3.1 Gen 1 and Gen 2 Hub and Hub-Combo Devices* ([www.microchip.com/en-us/application-notes/an262](http://www.microchip.com/en-us/application-notes/an262))
- *AN2932 - USB-to-GPIO Bridging with Microchip USB72xx Hubs* ([www.microchip.com/en-us/application-notes/an2932](http://www.microchip.com/en-us/application-notes/an2932))
- *AN2935 - Configuration of USB7206/USB7206C/USB7216/USB7216C/USB7252/USB7252C* ([www.microchip.com/en-us/application-notes/an2935](http://www.microchip.com/en-us/application-notes/an2935))
- *AN3135 - USB-to-I<sup>2</sup>S Bridging with Microchip Hubs* ([www.microchip.com/en-us/application-notes/an3135](http://www.microchip.com/en-us/application-notes/an3135))
- *AN3240 - USB-to-I<sup>2</sup>C Bridging with Microchip USB720x and USB725x Hubs* ([www.microchip.com/en-us/application-notes/an3240](http://www.microchip.com/en-us/application-notes/an3240))
- *USB 2.0 Specification*
- *USB 3.2 Specification*

#### 2.2 Pin Check

- Check the pinout of the part against the data sheet. Ensure that all pins match the data sheet and are configured as inputs, outputs, or bidirectional for error checking.

#### 2.3 Ground

- The ground pin, VSS, should be connected to the solid ground plane on the board.
- It is recommended that all ground connections be tied together to the same ground plane. Separate ground planes are not recommended.

#### 2.4 USB-IF Compliant USB Connectors

- USB-IF certified USB connectors with a valid Test ID (TID) are required for all USB products to be compliant and pass USB-IF product certification.

# USB7216C

## 3.0 POWER AND BYPASS CAPACITANCE

- The analog supplies (**VDD33**) require connections to a regulated 3.3V power plane.
  - For USB7216C, **VDD33** is located on pins 26, 43, 53, 62, 67, 79, 88, and 99.
- Each **VDD33** pin each should include a 0.1  $\mu\text{F}$  capacitor to decouple the device. The capacitor size should be SMD\_0603 or smaller.
- The analog supplies (**VCORE**) require connections to a regulated 1.15V power plane.
  - For USB7216C, **VCORE** is located on pins 9, 18, 25, 31, 38, 55, 78, 85, and 93.
- Each **VCORE** pin each should include a 0.1  $\mu\text{F}$  capacitor to decouple the device. The capacitor physical size should be SMD\_0603 or smaller.

The power and ground connections are shown in [Figure 3-1](#).

**FIGURE 3-1: POWER AND GROUND CONNECTIONS**

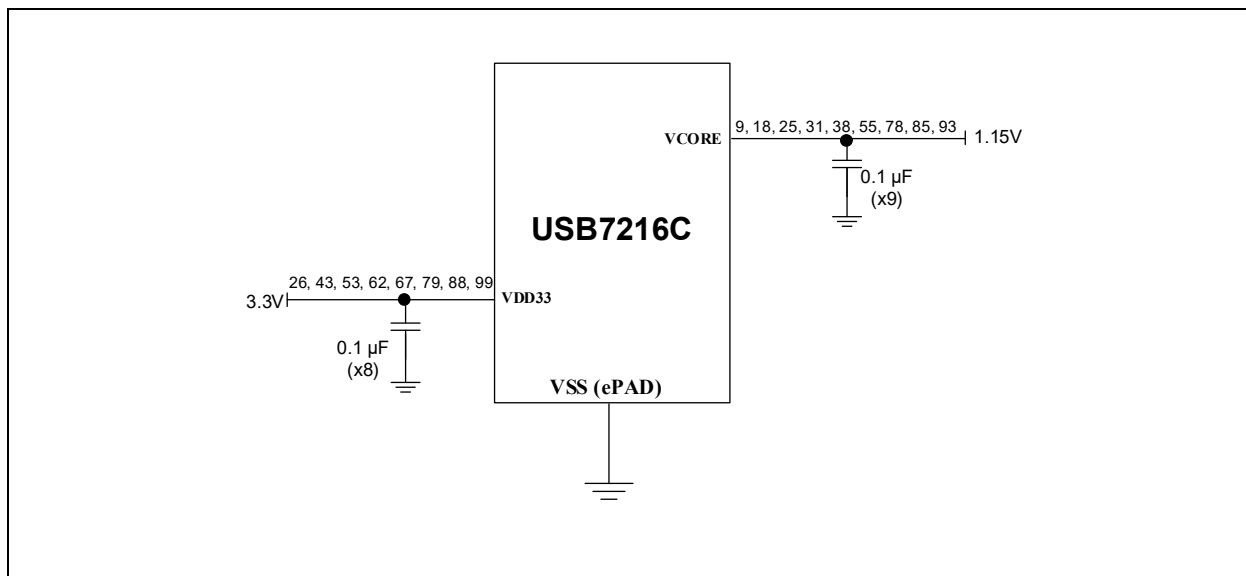

## 4.0 USB SIGNALS AND CONNECTIONS

### 4.1 Upstream Port USB Signals

- **USB2UP\_DP** (pin 89): This pin is the positive (+) signal of the upstream USB2.0 differential pair. All necessary USB terminations and resistors are included in the IC. This pin can connect directly to the D+/DP<sup>1</sup> pin of a USB connector.
- **USB2UP\_DM** (pin 90): This pin is the negative (–) signal of the upstream USB2.0 differential pair. All necessary USB terminations and resistors are included in the IC. This pin can connect directly to the D–/DM<sup>1</sup> pin of a USB connector.
- **USB3UP\_TXDP** (pin 91): This pin is the positive (+) signal of the upstream USB3.2 transmitter (TX) differential pair. All necessary USB terminations and resistors are included in the IC. This pin requires a series of 0.1 μF AC coupling capacitor before being connected directly to the TX+ (or TX–)<sup>2</sup> pin of the USB connector.
- **USB3UP\_TXDM** (pin 92): This pin is the negative (–) signal of the upstream USB3.2 TX differential pair. All necessary USB terminations and resistors are included in the IC. This pin requires a series of 0.1 μF AC coupling capacitor before being connected directly to the TX– (or TX+)<sup>2</sup> pin of the USB connector.
- **USB3UP\_RXDP** (pin 94): This pin is the positive (+) signal of the upstream USB3.2 receiver (RX) differential pair. All necessary USB terminations and resistors are included in the IC. It is advisable to add a 0.33 μF AC coupling capacitor in series before connecting to the USB connector.
- **USB3UP\_RXDM** (pin 95): This pin is the negative (–) signal of the upstream USB3.2 RX differential pair. All necessary USB terminations and resistors are included in the IC. This pin can be connected directly to the RX– (or RX+)<sup>2</sup> pin of the USB connector. It is advisable to add a 0.33 μF AC coupling capacitor in series before connecting to the USB connector.

**Note 1:** The polarity of any of the USB2.0 differential pairs may be inverted either intentionally due to design constraints or to correct a design error using the Microchip PortSwap feature. This feature may be configured via One-Time Programmable (OTP) or SMBus/I<sup>2</sup>C configuration registers.

**2:** A standard feature of USB3.2 is automatic polarity detection and correction. The positive and negative pins of the TX lines can be swapped with no adverse effect. Similarly, the positive and negative pins of the RX lines can also be swapped.

# USB7216C

For the standard Type-B port connection details, see [Figure 4-1](#).

**FIGURE 4-1: UPSTREAM PORT TYPE-B USB CONNECTIONS**

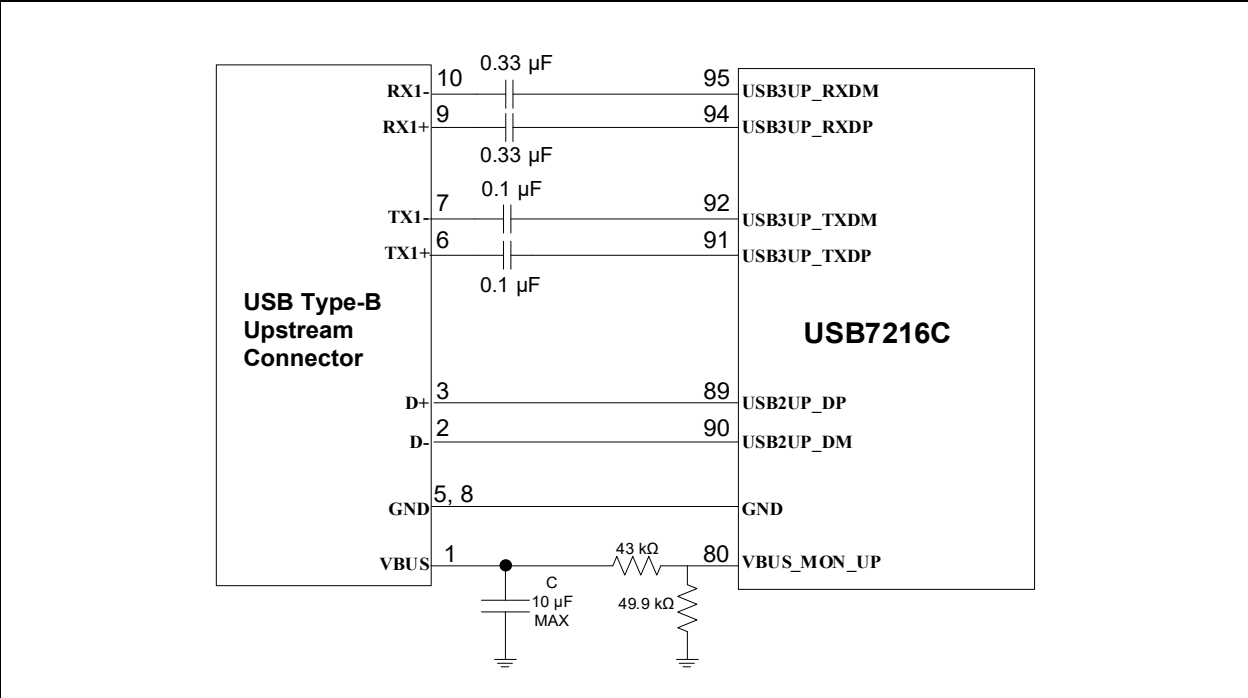

When connecting the upstream port to an embedded USB host, some pin connections change:

- The **VBUS\_MON\_UP** pin may be connected to an Enable output from the host processor. Alternatively, this can be tied to a 3.3V power rail, but a host control is recommended, whether it be through the **VBUS\_MON\_UP** pin or the **RESET\_N** pin. In any case, the voltage of the signal must be reduced to 2.7V for input to the USB7216C.
- Series capacitors are needed in both TX and RX USB signal pairs with an embedded host.

For an example on how to connect the upstream port to an embedded USB host, refer to [Figure 4-2](#).

**FIGURE 4-2: UPSTREAM PORT EMBEDDED HOST USB CONNECTIONS**

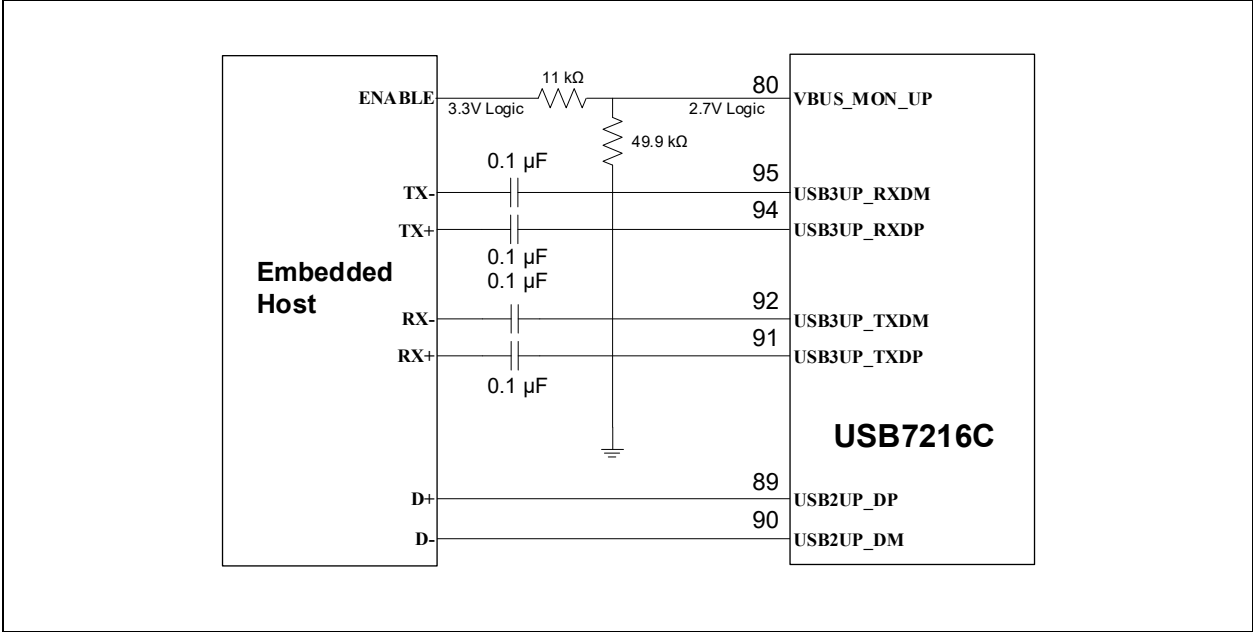

# USB7216C

When connecting the upstream port to a USB Type-C® connector, the following additional components are required:

- A basic upstream facing port (UFP) Type-C controller or a USB Power Delivery Type-C controller
- A 2:1 multiplexer (MUX) if Alt mode is not required or an Alt mode-specific cross bar switch

For an example on how to connect the upstream port to a USB Type-C port, refer to [Figure 4-3](#).

**FIGURE 4-3: UPSTREAM PORT USB TYPE-C® USB CONNECTIONS**

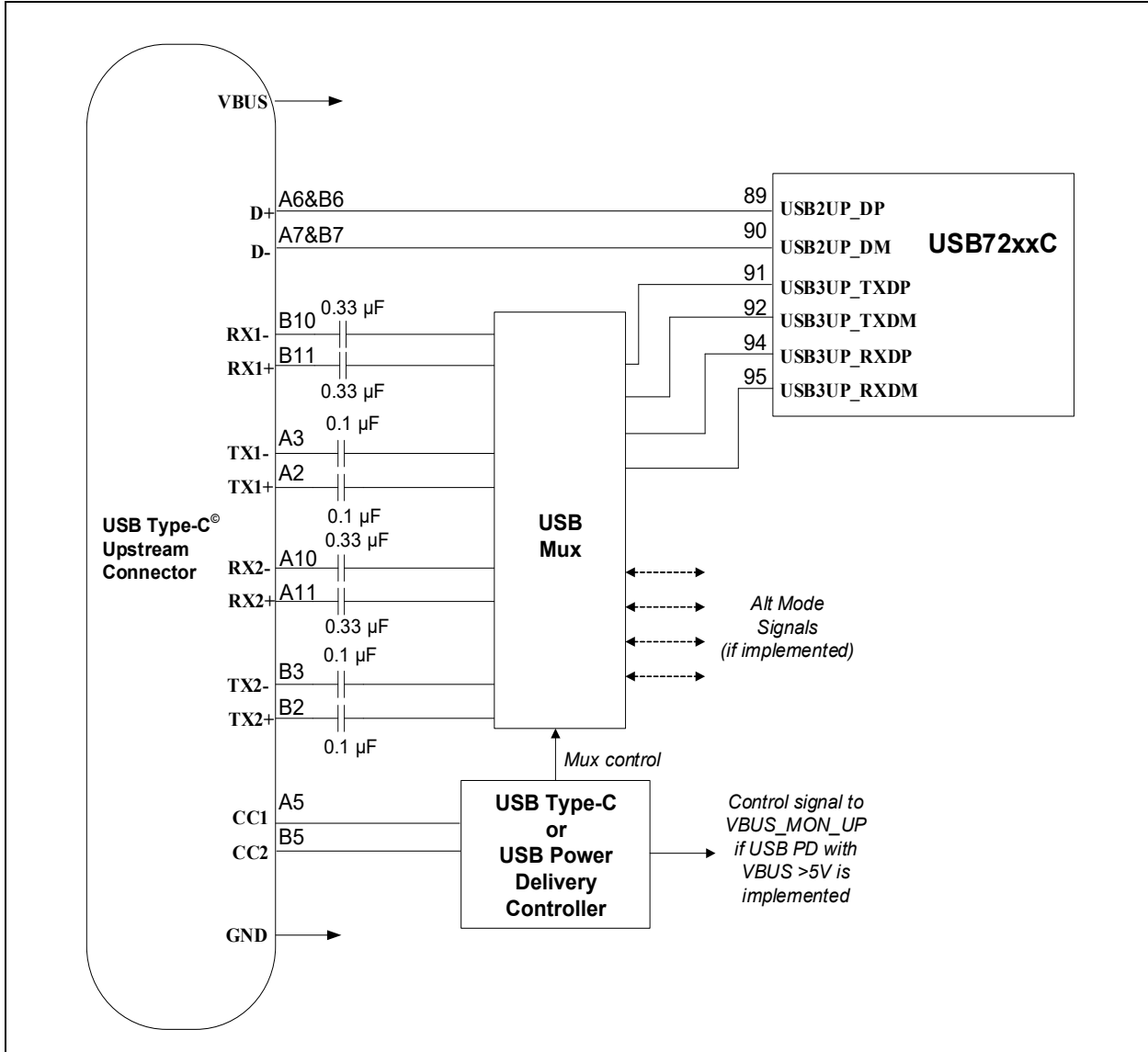

**Note:** Designers are advised to consult the USB3 mux device data sheet to for manufacturer recommendations on the use of 0.33 nF capacitors on RX lines.

## 4.2 Downstream USB Type-C® Port 1

### 4.2.1 DOWNSTREAM PORT 1 USB SIGNALS

- **USB2DN\_DP1** (pin 5): This pin is the positive (+) signal of the downstream port USB2.0 differential pair. All necessary USB terminations and resistors are included in the IC. This pin can connect directly to the D+/DP<sup>1</sup> pin of a USB connector.
- **USB2DN\_DM1** (pin 6): This pin is the negative (–) signal of the downstream port USB2.0 differential pair. All necessary USB terminations and resistors are included in the IC. This pin can connect directly to the D–/DM<sup>1</sup> pin of a USB connector.
- **USB3DN\_TXDP1A/USB3DN\_TXDP1B** (pin 7/16): This pin is the positive (+) signal of the downstream port USB3.2 TX differential pair. All necessary USB terminations and resistors are included in the IC. This pin requires a series of 0.1  $\mu$ F AC coupling capacitor before being connected directly to the TX+ (or TX–)<sup>2</sup> pin of the USB connector.
- **USB3DN\_TXDM1A/USB3DN\_TXDM1B** (pin 8/17): This pin is the negative (–) signal of the downstream port USB3.2 TX differential pair. All necessary USB terminations and resistors are included in the IC. This pin requires a series of 0.1  $\mu$ F AC coupling capacitor before being connected directly to the TX– (or TX+)<sup>2</sup> pin of the USB connector.
- **USB3DN\_RXDP1A/USB3DN\_RXDP1B** (pin 10/19): This pin is the positive (+) signal of the downstream port USB3.2 RX differential pair. All necessary USB terminations and resistors are included in the IC. This pin can be connected directly to the RX+ (or RX–)<sup>2</sup> pin of the USB connector. It is advisable to add a 0.33  $\mu$ F AC coupling capacitor in series before connecting to the USB connector.
- **USB3DN\_RXDM1A/USB3DN\_RXDM1B** (pin 11/20): This pin is the negative (–) signal of the downstream port USB3.2 RX differential pair. All necessary USB terminations and resistors are included in the IC. This pin can be connected directly to the RX– (or RX+)<sup>2</sup> pin of the USB connector. It is advisable to add a 0.33  $\mu$ F AC coupling capacitor in series before connecting to the USB connector.
- **DP1\_CC1/DP1\_CC2** (pin 12/13): This pin is used to detect a USB Type-C connection and insertion orientation. This should connect directly to the CC pins of the USB Type-C connector.

**Note 1:** The polarity of any of the USB2.0 differential pairs may be inverted either intentionally due to design constraints or to correct a design error using the Microchip PortSwap feature. This feature may be configured via OTP or SMBus/I<sup>2</sup>C configuration registers.

**2:** A standard feature of USB3.2 is automatic polarity detection and correction. The positive and negative pins of the TX lines can be swapped with no adverse effect. Similarly, the positive and negative pins of the RX lines can also be swapped.

# USB7216C

## 4.2.2 DOWNSTREAM PORT 1 TYPE-C USB SIGNAL CONNECTIONS

For standard Type-C port connection details, refer to [Figure 4-4](#).

**FIGURE 4-4: DOWNSTREAM PORT 1 TYPE-C® USB CONNECTIONS**

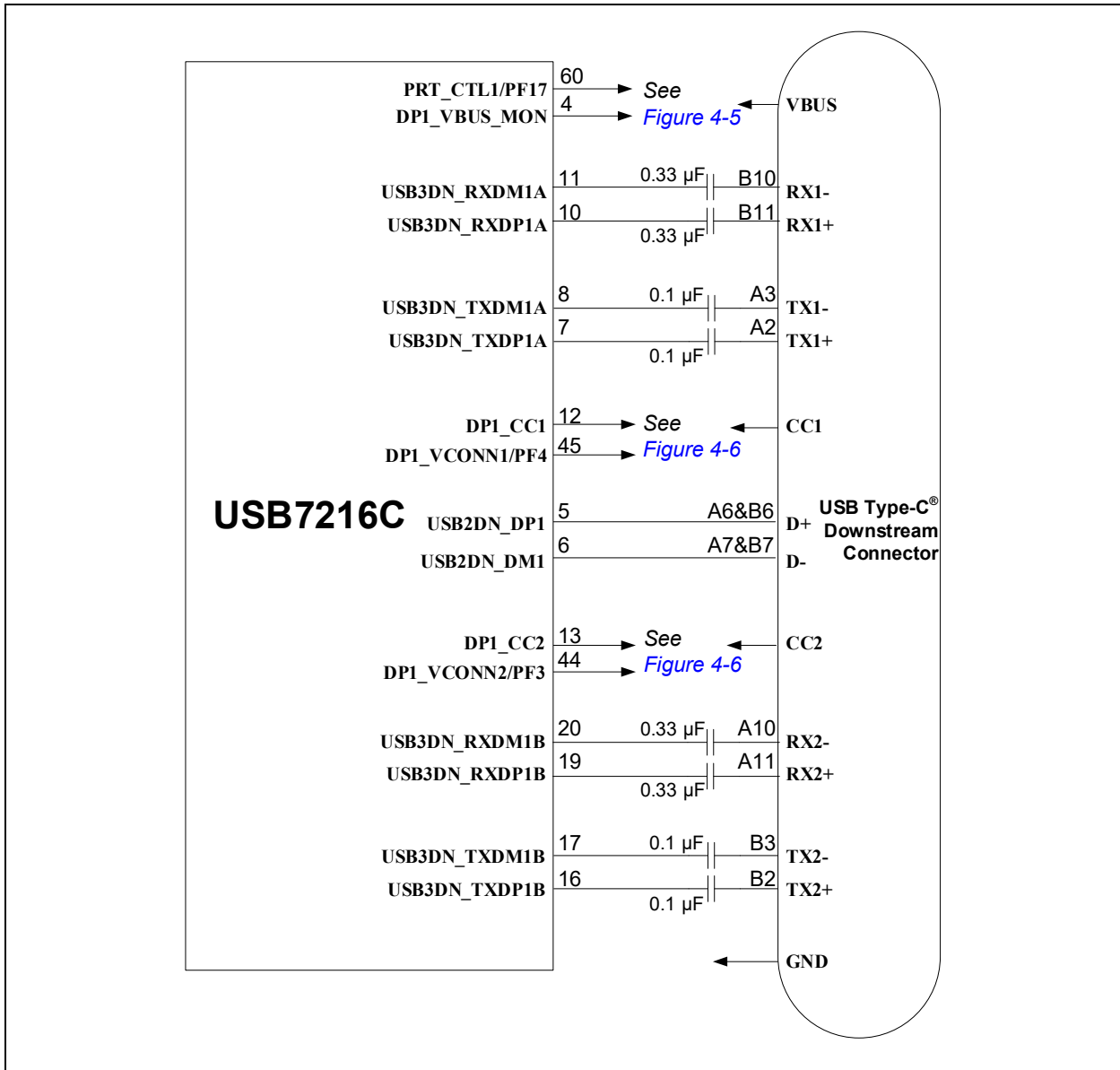

When connecting the upstream port to a Type-B connector, some pin connections change:

- All of the TX and RX pins with suffix 'B' should be left floating.
- The DP<sub>x</sub>\_CC1 pin should be connected directly to ground through a 5.1 kΩ pull-down resistor.
- The DP<sub>x</sub>\_CC2 pin should be left floating.
- DP<sub>x</sub>\_VCONN1 and DP<sub>x</sub>\_VCONN2 pins should be left floating.

## 4.2.3 DOWNSTREAM PORT 1 USB TYPE-C VBUS AND PRT\_CTL1 CONNECTIONS

Port Power Control is required for bus-powered devices and battery charging.

The **PRT\_CTL1** pin is a hybrid input/output (I/O) pin that has the following states:

- **PORT OFF:** **PRT\_CTL1** is an output and drives low. The **PRT\_CTL1** pin only transitions to the PORT ON state through a specific command from the USB host.
- **PORT ON:** **PRT\_CTL1** is an input with a weak internal pull-up enabled. The input buffer monitors overcurrent events, which are indicated by the port power controller by pulling the **PRT\_CTL1** line low. Once an overcurrent event is detected, the **PRT\_CTL1** automatically moves to the PORT OFF state until the USB host can be notified of the overcurrent event.

When connecting the **PRT\_CTL1** pin to a port power controller, the signal should be connected to both the Enable and the Fault indicator pins of the port power controller. Do not place an external pull-up resistor on the line.

**Note:** The overcurrent detect debounce parameters are configurable and may be adjusted if required to operate properly with the selected port power controller.

The **DPI\_VBUS\_MON** pin is an input with a preconfigured set of comparator banks. These comparator banks are used to monitor the voltage on the **VBUS** pin to ensure that the voltage is within the correct range while in the **VBUS ON** and **OFF** states ('vSafe5V' and 'vSafe0V', respectively). The recommended connection to **VBUS** is through a resistor divider of 43 kΩ over 49.9 kΩ. This pin must be connected per this guidance and may not be left floating or unused.

The **DPI\_DISCHARGE** pin is an output that asserts whenever power to **VBUS** is transitioning from **ON** to **OFF** ('vSafe5V' to 'vSafe0V'). This pin can be connected to a transistor that should turn on and short **VBUS** to **GND** when this signal asserts to 3.3V. A series resistor within the 400Ω to 700Ω range is recommended to limit the current through the transistor and to add discharge slew rate controllability. When discharging the **VBUS** pin, the voltage must reach the vSafe0V voltage window within the discharge time as defined in the USB Type-C Specification (see the latest revision for the most up-to-date timing and voltage requirements).

Some port power controllers have an automatic discharge function when they are shut off. In that case, the **DPI\_DISCHARGE** pin may be left floating.

A typical Type-C implementation is shown in [Figure 4-5](#).

**FIGURE 4-5: DOWNSTREAM PORT 1 USB TYPE-C® VBUS AND PRT\_CTL CONNECTIONS**

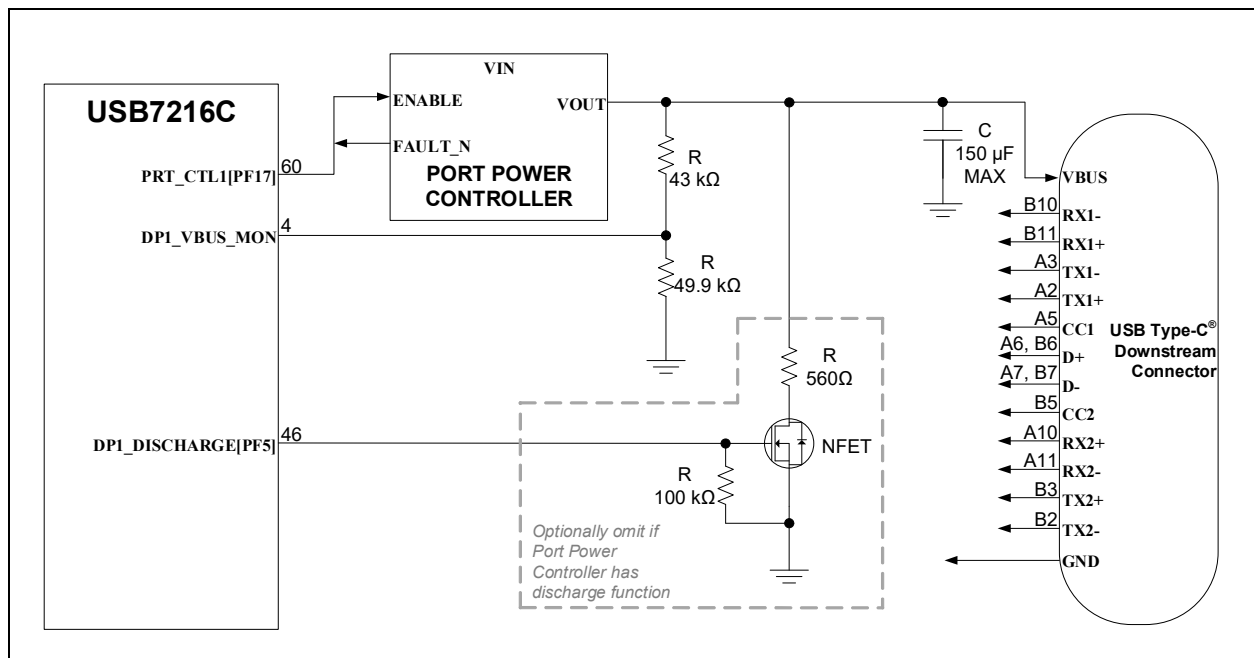

**Note:** The implementation as shown in [Figure 4-5](#) assumes that the port power controller has an active-high Enable input, and an active-low, open-drain-style Fault indicator. External polarity inversion through buffers or FETs may be required if the port power controller has different I/O characteristics.

# USB7216C

## 4.2.4 DOWNSTREAM PORT 1 CC1 AND CC2 CONNECTIONS

If connecting downstream port 1 to a Type-A port, see [Figure 4-7](#).

If connecting downstream port 1 to an embedded USB device, see [Figure 4-6](#).

**DPI\_CC1** and **DPI\_CC2** of downstream port 1 of USB7216C are designed to connect directly to the respective CC1 and CC2 pins of the Type-C connector.

**DPI\_VCONN1** and **DPI\_VCONN2** of downstream port 1 of USB7216C are active-high control signals that assert when the VCONN should be supplied to an active or electronically marked cable or to a VCONN powered accessory. The VCONN supply for a standard Type-C application must be capable of supplying 1W of VCONN power to each Type-C downstream port. For the VCONN power supply, 5V is recommended though lower voltages are also supported. The recommended arrangement is an NFET to invert the polarity of the control signal, and a PFET pass transistor for the VCONN voltage.

VCONN overcurrent is sensed by voltage drop on the CCx pin. A diode and a low impedance series resistor may be necessary to ensure this voltage drop is achieved when VCONN current draw exceeds the desired overcurrent threshold. The diode and resistor characteristics should be tuned by the system designer to match the exact desired overcurrent setting.

A typical implementation is shown in [Figure 4-6](#).

**FIGURE 4-6: DOWNSTREAM PORT 1 CC1 AND CC2 CONNECTIONS**

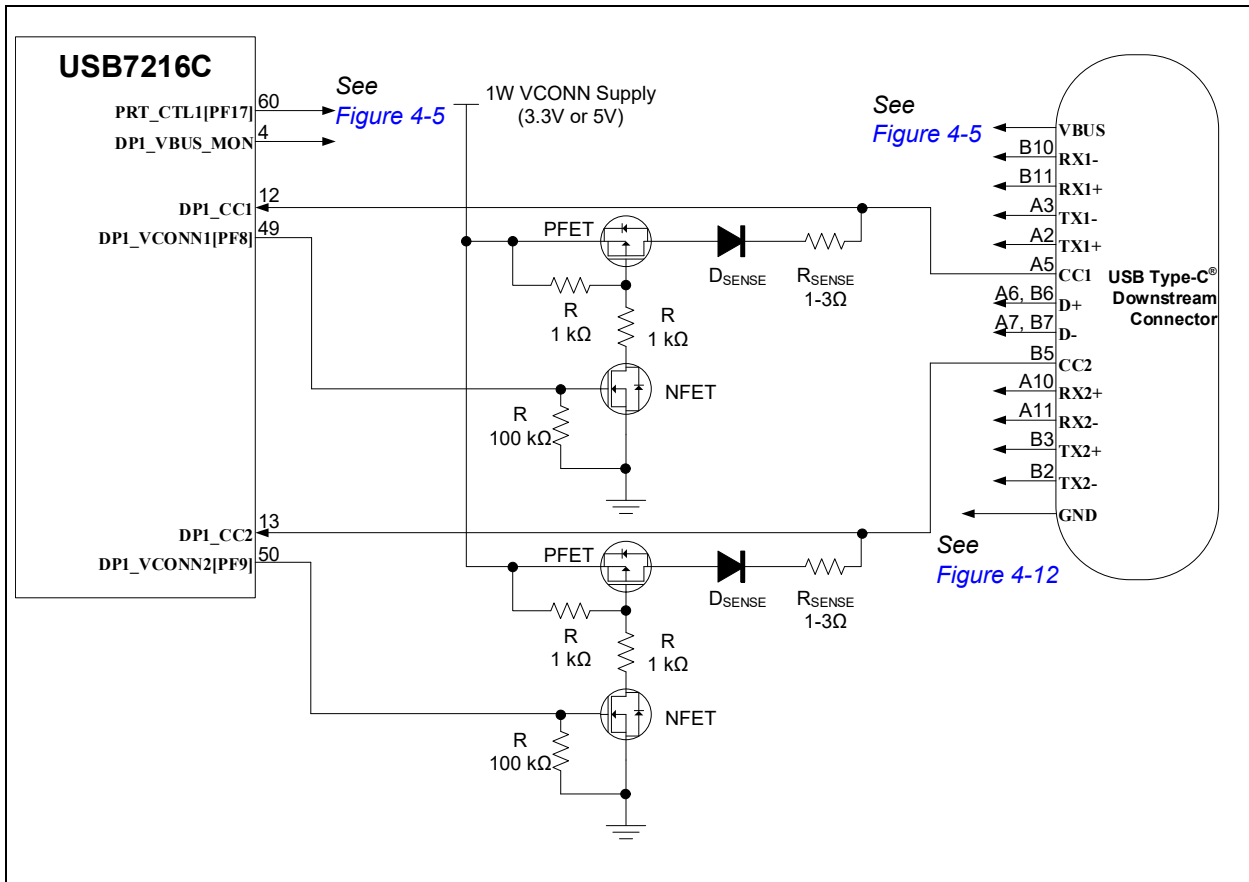

**Note:** The implementation as shown in [Figure 4-6](#) assumes that the USB Type-C controller has an active-high Enable input, and the port power controller have an active-low, open-drain-style Fault indicator. External polarity inversion through buffers or FETs may be required if the USB Type-C controller, port power controller, or both have different I/O characteristics.

## 4.2.5 DOWNSTREAM PORT 1 TYPE-A VBUS AND PRT\_CTL1 CONNECTIONS

When connecting downstream port 1 to a standard Type-A port, the **DP1\_VBUS\_MON** pin must still be connected in the same manner, but **DP1\_DISCHARGE** may be left disconnected, as a standard Type-A port is an 'always on' port that does not require fast discharging.

A typical Type-A implementation is shown in [Figure 4-7](#).

**FIGURE 4-7: DOWNSTREAM PORT 1 VBUS AND PRT\_CTLX CONNECTIONS FOR TYPE-A PORT**

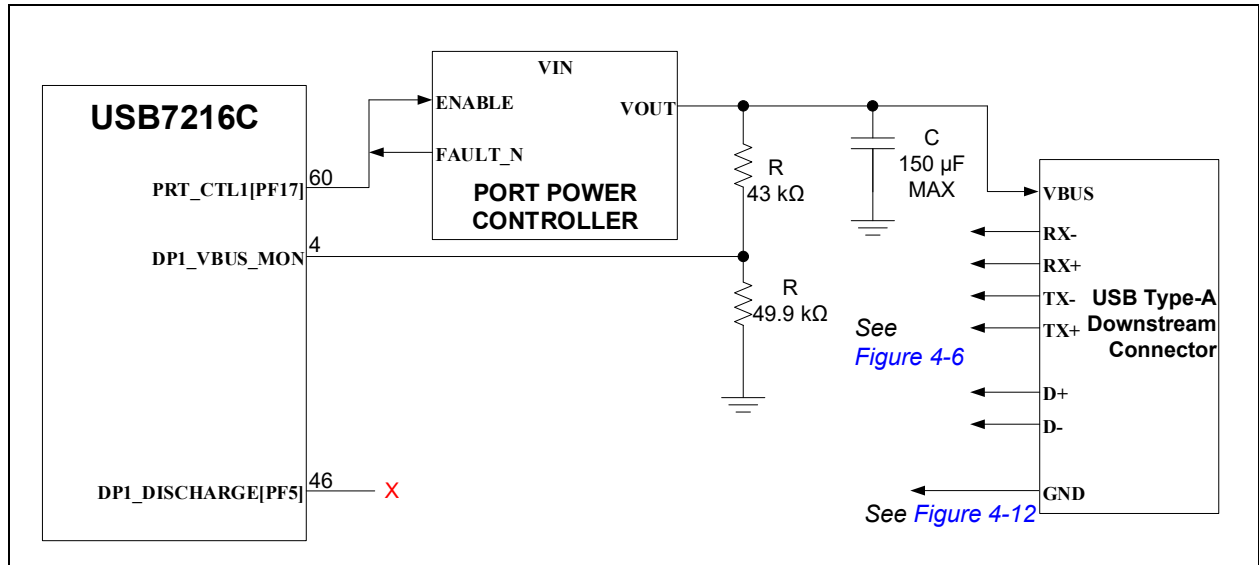

**Note:** The implementation as shown in [Figure 4-7](#) assumes that the port power controller has an active-high Enable input, and an active-low, open-drain-style Fault indicator. External polarity inversion through buffers or FETs may be required if the port power controller has different I/O characteristics.

# USB7216C

## 4.2.6 DOWNSTREAM PORT 1 EMBEDDED DEVICE CONNECTIONS

For an example on how to connect downstream port 1 to an embedded USB3.2 device, refer to [Figure 4-8](#).

**FIGURE 4-8: DOWNSTREAM PORT 1 EMBEDDED DEVICE USB CONNECTIONS**

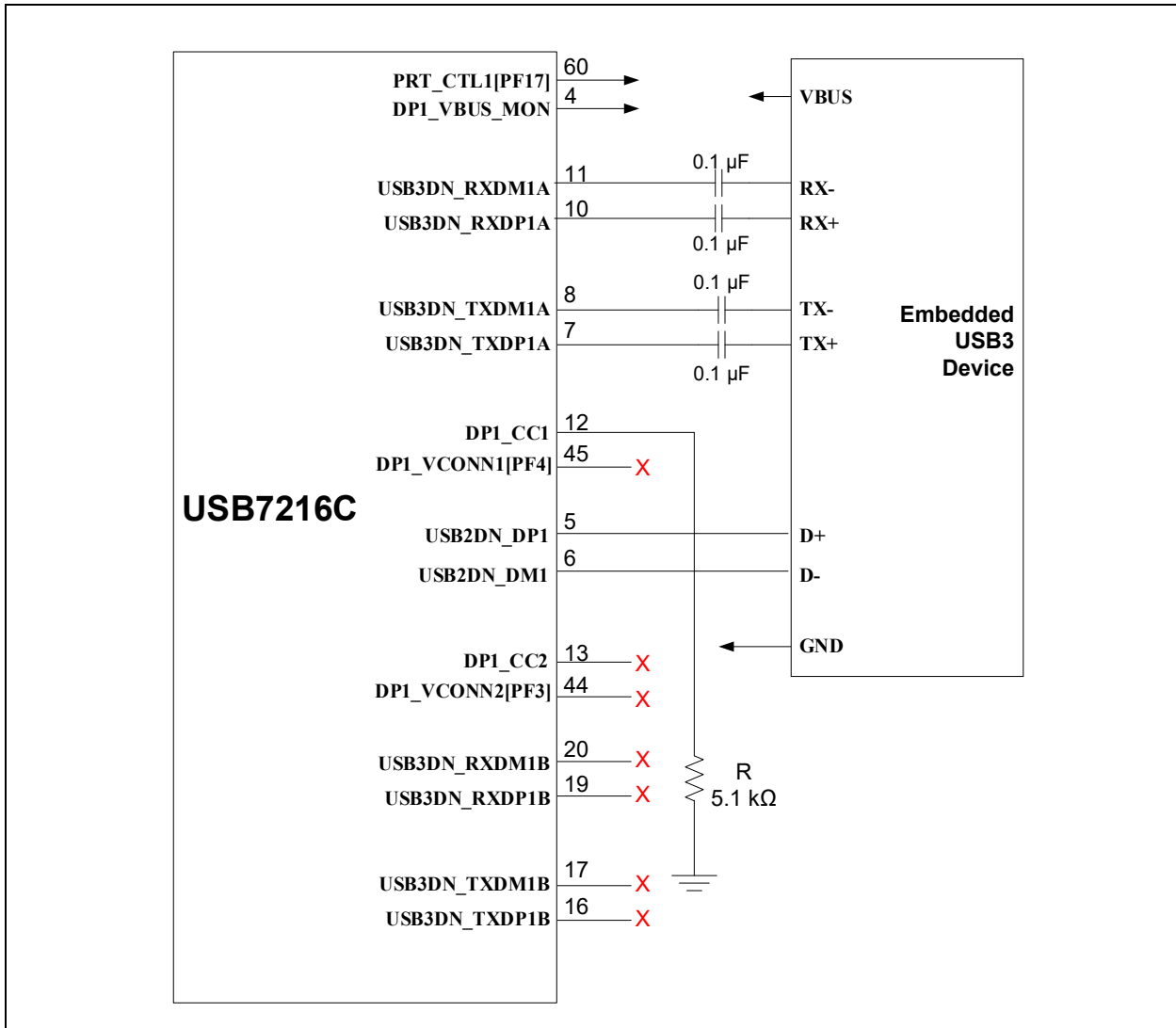

## 4.3 Downstream Ports 2-6

Ports 2, 3, and 4 are Type-A USB3 ports. Ports 5 and 6 are Type-A USB2 ports that have no USB3 signal.

### 4.3.1 DOWNSTREAM TYPE-A USB SIGNALS

- **USB2DN\_DP<sub>x</sub>** (pin 27/34/81/14/42): This pin is the positive (+) signal of the downstream port USB2.0 differential pair. All necessary USB terminations and resistors are included in the IC. This pin can connect directly to the D+/  
DP<sup>1</sup> pin of a USB connector.
- **USB2DN\_DM<sub>x</sub>** (pin 28/35/82/15/41): This pin is the negative (–) signal of the downstream port USB2.0 differential pair. All necessary USB terminations and resistors are included in the IC. This pin can connect directly to the D–/  
DM<sup>1</sup> pin of a USB connector.
- **USB3DN\_TXDP<sub>x</sub>** (pin 29/36/83): This pin is the positive (+) signal of the downstream port USB3.2 TX differential pair. All necessary USB terminations and resistors are included in the IC. This pin requires a series of 0.1 μF AC coupling capacitor before being connected directly to the TX+ (or TX–)<sup>2</sup> pin of the USB connector.
- **USB3DN\_TXDM<sub>x</sub>** (pin 30/37/84): This pin is the negative (–) signal of the downstream port USB3.2 TX differential pair. All necessary USB terminations and resistors are included in the IC. This pin requires a series of 0.1 μF AC coupling capacitor before being connected directly to the TX– (or TX+)<sup>2</sup> pin of the USB connector.
- **USB3DN\_RXDP<sub>x</sub>** (pin 32/39/86): This pin is the positive (+) signal of the downstream port USB3.2 RX differential pair. All necessary USB terminations and resistors are included in the IC. This pin can be connected directly to the RX+ (or RX–)<sup>2</sup> pin of the USB connector. It is advisable to add a 0.33 μF AC coupling capacitor in series before connecting to the USB connector.
- **USB3DN\_RXDM<sub>x</sub>** (pin 33/40/87): This pin is the negative (–) signal of the downstream port USB3.2 RX differential pair. All necessary USB terminations and resistors are included in the IC. This pin can be connected directly to the RX– (or RX+)<sup>2</sup> pin of the USB connector. It is advisable to add a 0.33 μF AC coupling capacitor in series before connecting to the USB connector.

**Note 1:** The polarity of any of the USB2.0 differential pairs may be inverted either intentionally due to design constraints or to correct a design error using the Microchip PortSwap feature. This feature may be configured via OTP or SMBus/I2C configuration registers.

**2:** A standard feature of USB3.2 is automatic polarity detection and correction. The positive and negative pins of the TX lines can be swapped with no adverse effect. Similarly, the positive and negative pins of the RX lines can also be swapped.

- **PRT\_CTL<sub>x</sub>** can be connected directly to the Enable signal of the USB3.2 device, assuming a 3.3V logic level is required by the device. This gives the USB host the ability to reset the device through standard USB protocol.

### 4.3.2 DOWNSTREAM PORTS 2, 3, AND 4 VBUS AND VBUS\_MON\_UP AND USB SIGNALS

The **PRT\_CTL<sub>x</sub>** pin is a hybrid I/O pin that has the following states:

- **PORT OFF:** **PRT\_CTL<sub>x</sub>** is an output and drives low. The **PRT\_CTL<sub>x</sub>** pin only transitions to the PORT ON state through a specific command from the USB host.
- **PORT ON:** **PRT\_CTL<sub>x</sub>** is an input with a weak internal pull-up enabled. The input buffer monitors overcurrent events, which are indicated by the port power controller by pulling the **PRT\_CTL<sub>x</sub>** line low. Once an overcurrent event is detected, the **PRT\_CTL<sub>x</sub>** automatically moves to the PORT OFF state until the USB host can be notified of the overcurrent event.

When connecting the **PRT\_CTL<sub>x</sub>** pin to a port power controller, the signal should be connected to both the Enable and the Fault indicator pins of the port power controller. Do not place an external pull-up resistor on the line.

**Note:** The overcurrent detect debounce parameters are configurable and may be adjusted if required to operate properly with the selected port power controller.

# USB7216C

A typical Type-A implementation is shown in [Figure 4-9](#).

**FIGURE 4-9: DOWNSTREAM PORTS 2, 3, AND 4 USB SIGNAL AND VBUS CONNECTIONS**

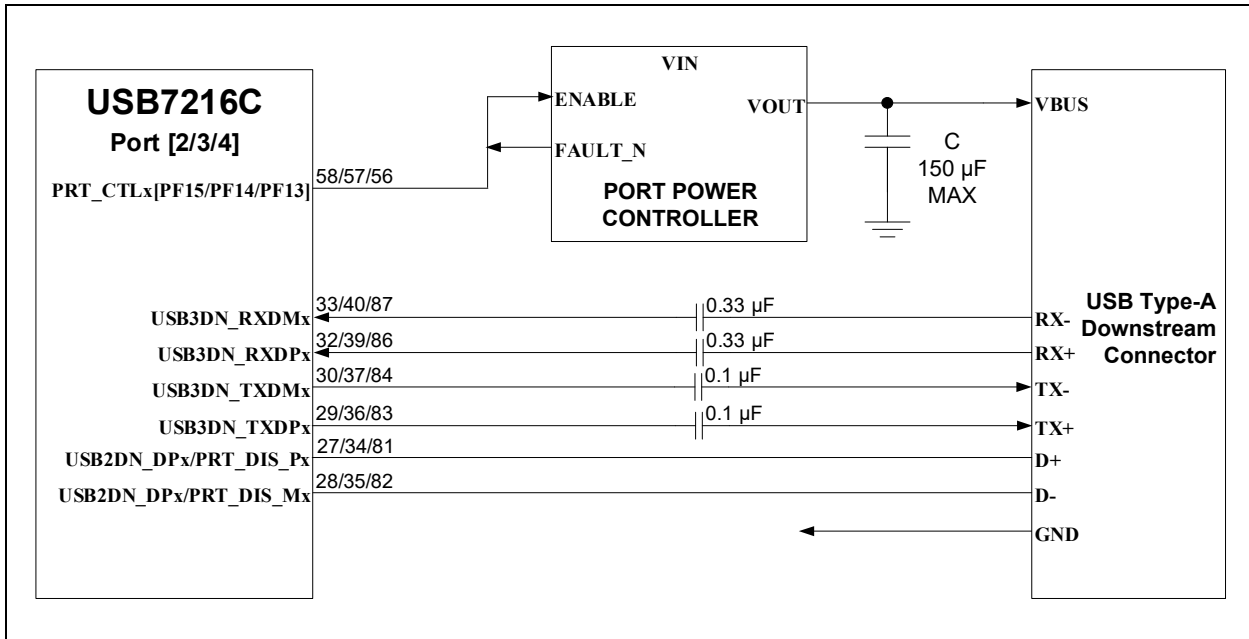

### 4.3.3 DOWNSTREAM EMBEDDED USB3 DEVICE

For an example on how to connect downstream port 2, 3, or 4 to an embedded USB3.2 device, refer to [Figure 4-10](#).

**FIGURE 4-10: DOWNSTREAM PORTS 2, 3, OR 4 EMBEDDED DEVICE USB CONNECTIONS**

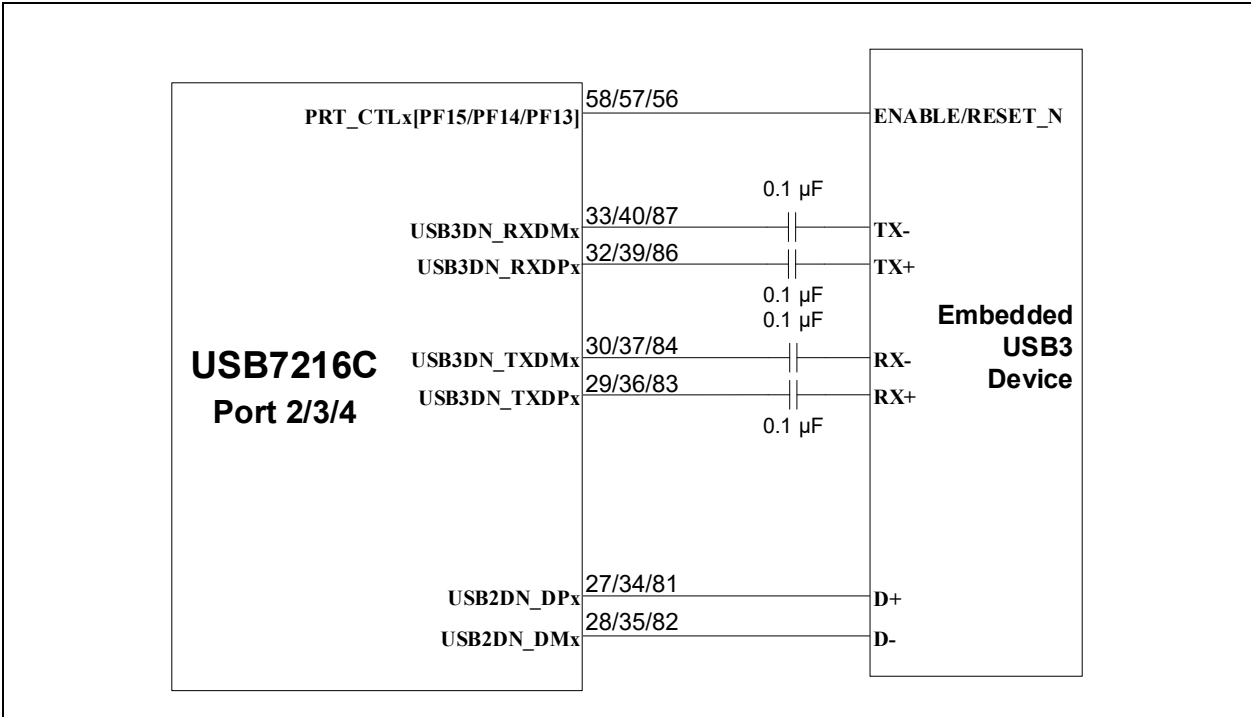

# USB7216C

## 4.3.4 DOWNSTREAM PORTS 5 AND 6 VBUS AND PRT\_CTL CONNECTIONS

Downstream ports 5 and 6 are basic USB2.0-only ports, and they do not include `DPx_VBUS_MON` and `DPx_DISCHARGE` pins.

A typical downstream port 5 and 6 Type-A implementation is shown in [Figure 4-11](#).

**FIGURE 4-11: DOWNSTREAM PORTS 5 AND 6 VBUS AND PRT\_CTLX CONNECTIONS**

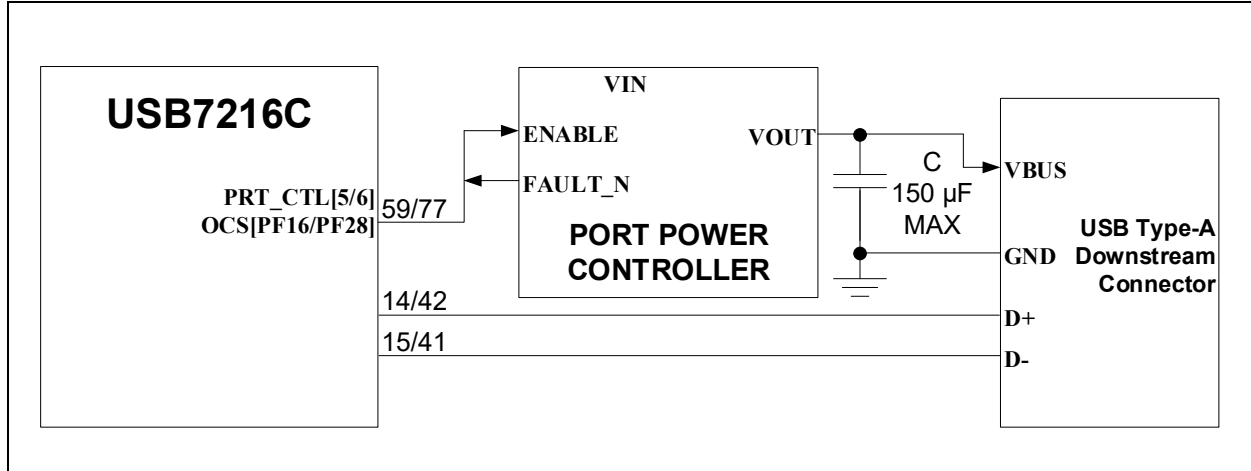

**Note:** The implementation as shown in [Figure 4-11](#) assumes that the port power controller has an active-high Enable input, and an active-low, open-drain-style Fault indicator. External polarity inversion through buffers or FETs may be required if the port power controller has different I/O characteristics.

## 4.4 Disabling Downstream Ports

If a downstream port of the USB7216C is unused, it should be disabled. This can be achieved through hub configuration (`I2C` or OTP), or through a port disable strap option.

If using the port disable strap option, the `USB2DN_DPx` and `USB2DN_DMx` signals should be pulled high to 3.3V. This connection can be made directly to the 3.3V power net, or through a pull-up resistor. All other signals related to the associated port may be floated.

## 4.5 USB Protection

The use of external protection circuitry may be required to provide additional ESD protection beyond what is included in the hub IC. These generally are grouped into three categories:

1. TVS protection diodes
  - ESD protection for IEC-61000-4-2 system-level tests
2. Application-targeted protection ICs or galvanic isolation devices
  - DC overvoltage protection for short-to-battery protection
3. Common-mode chokes
  - For EMI reduction

The USB7216C can be used in conjunction with these types of devices, but these devices may have negative effect on USB signal integrity. It is important to select components accordingly and follow implementation guidelines from the device manufacturer. The following general guidelines for implementing these devices may also be followed:

- Select only devices that are designed specifically for high-speed applications. Per the USB2.0 Specification, a total of 5 pF is budgeted for connector, PCB traces, and protection circuitry. In a USB3.2 Gen 1 system, ESD protection should add no more than 0.5 pF capacitance to the differential pairs.
- Place these devices as close as possible to the USB connector.
- Never branch the USB signals to reach protection devices. Always place the protection devices directly on top of the USB differential traces.
- Always ensure a very low impedance path to a large ground plane. The effectiveness of TVS devices depends heavily on effective grounding.
- Place TVS diodes on the same layer as the USB signal trace. Avoid vias or place vias behind the TVS device if possible.

### 4.5.1 ADDITIONAL PROTECTION OPTIONS FOR USB3 PINS

In addition to TVS diodes, some or all of the following may be implemented:

- Use decoupling capacitors on both the TX and RX differential pairs. Decoupling capacitors on the RX pairs are not required for operation, but add some additional ESD immunity at low cost.
- Use decoupling capacitors with high voltage ratings. 0.1  $\mu$ F capacitors at 0402 sizes are widely available.
- A very small resistor of 0.3-0.5W may be placed in series with the decoupling capacitor (placed physically between the TVS diode and the decoupling capacitor) to help steer more of the ESD energy through the TVS diode. A resistor network (two-resistor/four-contact) in 0402 or 0201 size can be placed with very little impact to the differential routing of the signals.

**Note:** Microchip PHYBoost, VariSense™, and High-Speed Disconnect Threshold adjustment configuration options are available for compensating the negative effects of these devices. These features can help to overcome marginal failures. It is simplest to determine the appropriate setting using laboratory experiments, such as USB eye diagram tests, on physical hardware.

# USB7216C

## 4.6 GND and SHIELD Recommendations

The GND pins of the USB connector must be connected to the PCB with a low impedance path directly to a large GND plane.

The SHIELD pins of the USB connector may be connected in one of two ways:

1. (Recommended) Connect to GND through a resistor and a capacitor in parallel. A resistor-capacitor (RC) filter can help to decouple and minimize EMI between a PCB and a USB cable.
2. Connect directly to the GND plane.

The recommended implementation is shown in [Figure 4-12](#).

**FIGURE 4-12: RECOMMENDED USB CONNECTOR GND AND SHIELD CONNECTIONS**

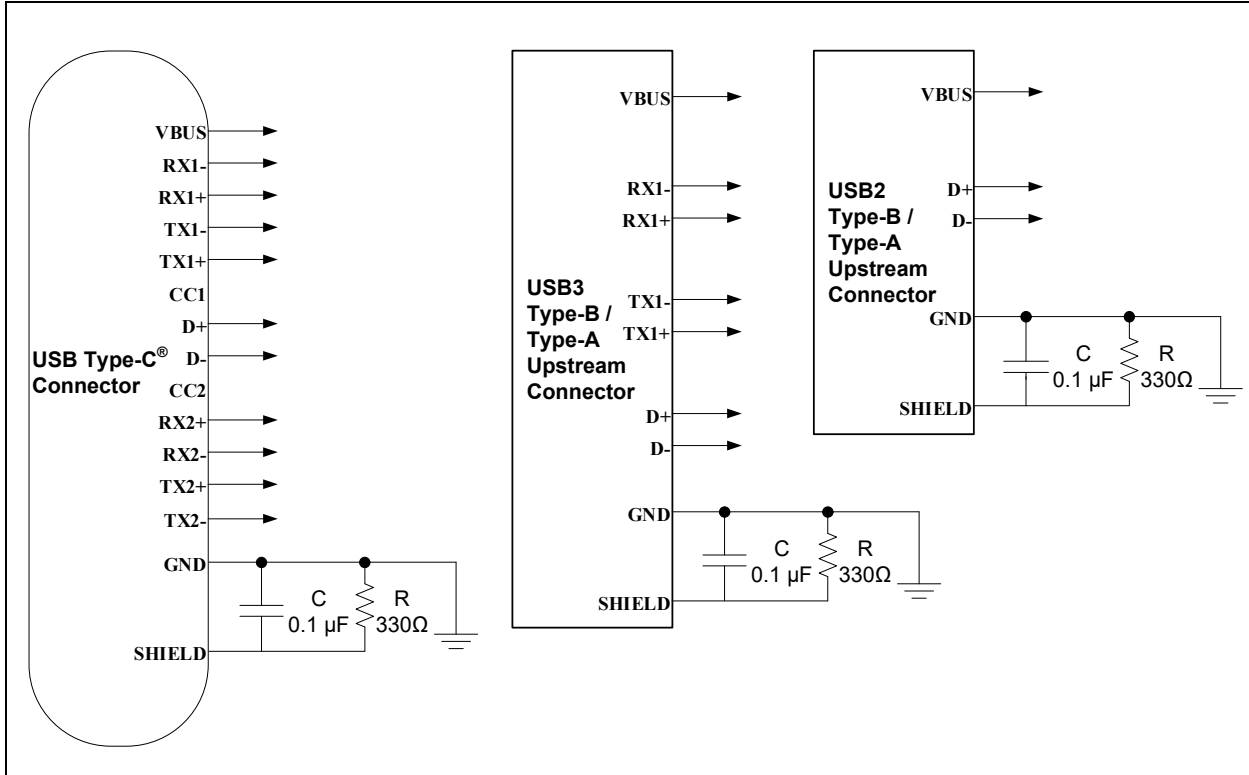

## 5.0 CLOCK CIRCUIT

### 5.1 Crystal and External Clock Connection

A 25.000 MHz ( $\pm 50$  ppm) reference clock is the source for the USB interface and for all other functions of the device. For exact specifications and tolerances, refer to the latest revision of the *USB7216C Data Sheet*.

- **XTALI** (pin 98) is the clock circuit input for the USB7216C. This pin requires a capacitor to ground. One side of the crystal connects to this pin.
- **XTALO** (pin 97) is the clock circuit output for the USB7216C. This pin requires a capacitor to ground. One side of the crystal connects to this pin.
- The crystal loading capacitor values are system-dependent, which are based on the total  $C_L$  spec of the crystal and the stray capacitance value. The PCB design, crystal, and layout all contribute to the characteristics of this circuit. A commonly used formula for calculating the appropriate physical  $C_1$  and  $C_2$  capacitor values is:

$$C_L = ((C_{X1})(C_{X2}) / (C_{X1} + C_{X2}))$$

Where,  $C_L$  is the spec from the crystal data sheet,  $C_{X1} = C_{\text{stray}} + C_1$ ,  $C_{X2} = C_{\text{stray}} + C_2$ .

**Note:**  $C_{\text{stray}}$  is the stray or parasitic capacitance due to PCB layout. It can be assumed to be very small, in the 1 pF-2 pF range, and then verified by physical experiments in the lab if PCB simulation tools are not available.

- Alternatively, a 25.000 MHz, 3.3V clock oscillator may be used to provide the clock source for the USB7216C. When using a single-ended clock source, **XTALO** (pin 97) should be left floating as a No Connect (NC).

**FIGURE 5-1: CRYSTAL AND OSCILLATOR CONNECTIONS**

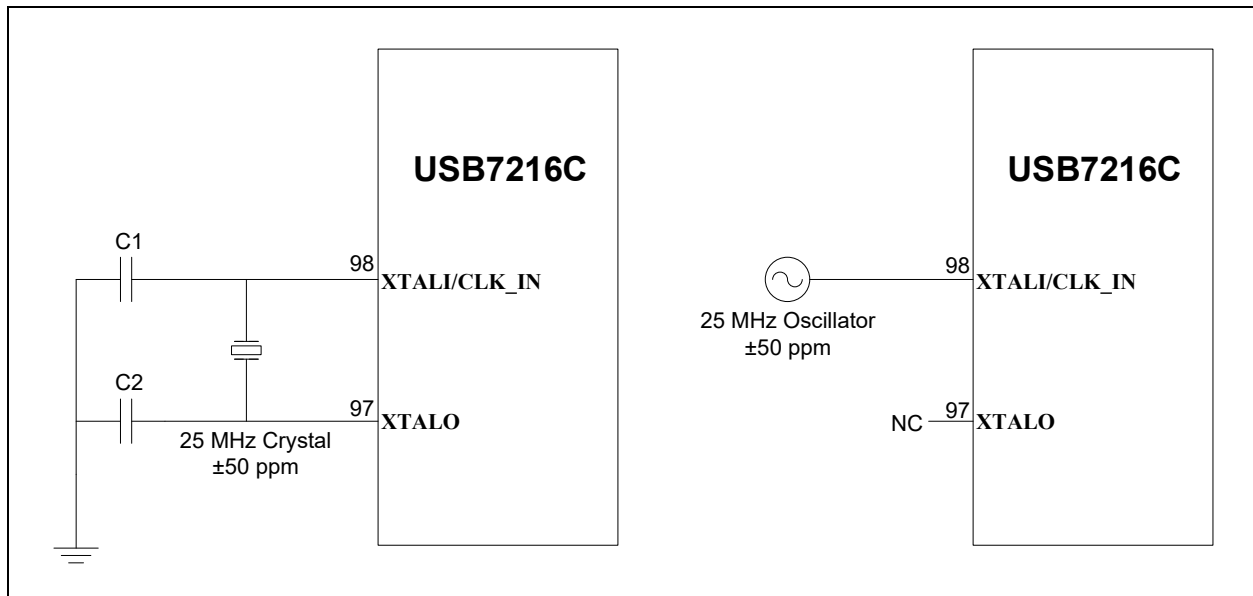

# USB7216C

## 6.0 POWER AND STARTUP

### 6.1 RBIAS Resistor

The **RBIAS** pin on the USB7216C must connect to ground through a 12 k $\Omega$  resistor with a tolerance of 1.0%. This is used to set up critical bias currents for the internal circuitry. This should be placed as close as possible to the IC pin, and be given a dedicated, low-impedance path to a ground plane.

### 6.2 Board Power Supplies

#### 6.2.1 POWER RISE TIME

The power rail voltage and rise time should adhere to the supply rise time specification as defined in the *USB7216C Data Sheet*.

If a monotonic or fast power rail rise cannot be assured, then the **RESET\_N** signal should be controlled by a Reset supervisor and only released when the power rail has reached a stable level.

#### 6.2.2 CURRENT CAPABILITY

It is important to size the 5V and 3.3V power rails appropriately. The 5V power supply must be capable of supplying 500 mA (if BC1.2 is not enabled), 1.5A (if BC1.2 is enabled), or up to 3.0A (if the maximum Type-C current is enabled) to the USB downstream port VBUS without dropping below the minimum voltage permissible in the USB Specification.

The 3.3V and 1.15V power supply must be able to supply enough power to the USB hub IC. It is recommended that the 3.3V and 1.15V power rails be sized such that they are able to supply maximum power consumption specification as displayed in the *USB7216C Data Sheet*.

### 6.3 Reset Circuit

**RESET\_N** (pin 28) is an active-low Reset input. This signal resets all logic and registers within the USB7216C. A hardware Reset (**RESET\_N** assertion) is not required following power-up. Refer to the latest copy of the *USB7216C Data Sheet* for Reset timing requirements. [Figure 6-1](#) shows a recommended Reset circuit for powering up the USB7216C when Reset is triggered by the power supply.

**FIGURE 6-1: RESET TRIGGERED BY POWER SUPPLY**

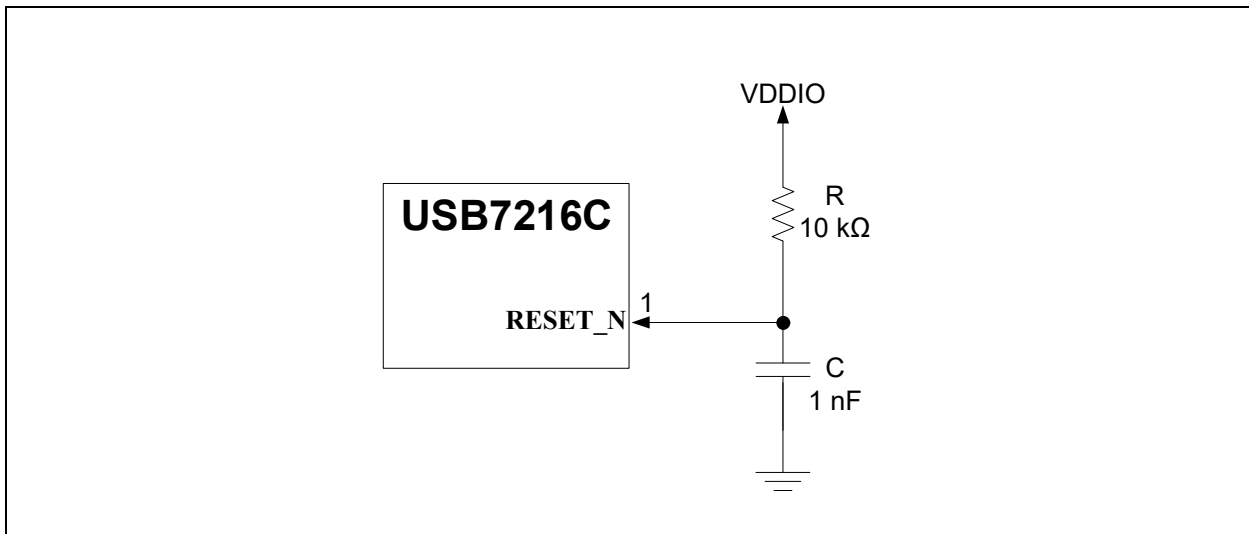
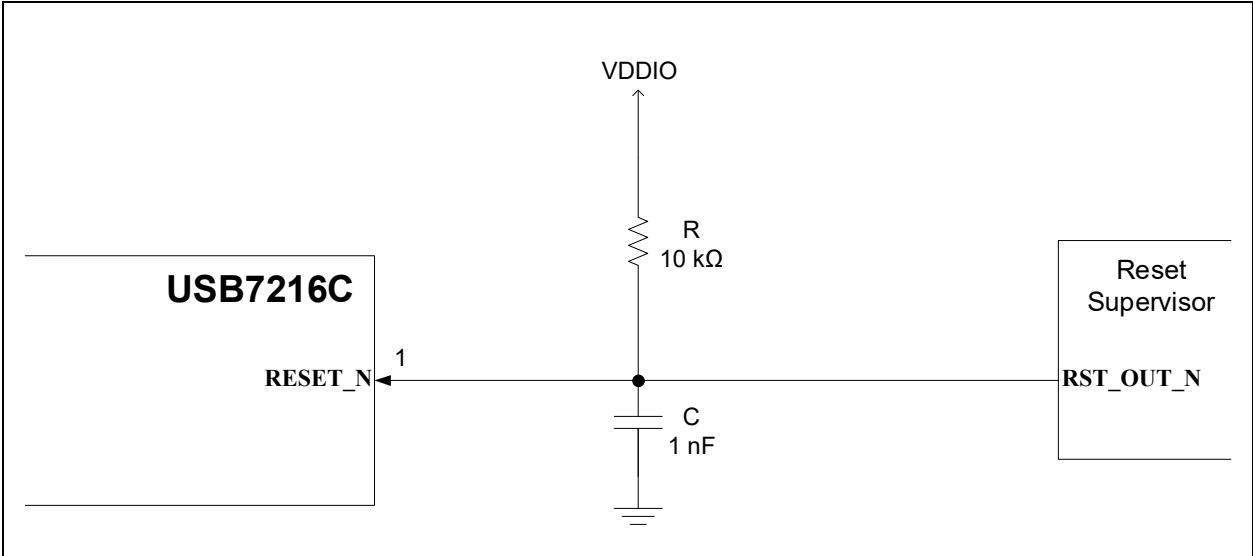

Figure 6-2 details the recommended Reset circuit for applications where Reset is driven by an external CPU/MCU. The Reset out pin (RST\_OUT\_N) from the CPU/MCU provides the warm Reset after power-up.

**FIGURE 6-2: RESET CIRCUIT INTERFACE WITH CPU/MCU/SUPERVISOR RESET OUTPUT**



# USB7216C

---

## 7.0 EXTERNAL SPI MEMORY

### 7.1 SPI Operation Summary

By default, the USB7216C executes firmware from an internal read only memory (ROM). The USB7216C supports optional firmware execution from an external SPI Flash device. An SPI Flash device is only required if a custom firmware is required for the application.

The SPI interface can operate at 60 MHz or 30 MHz. It can also operate in Dual mode or Quad mode.

The firmware image can be executed in one of two ways:

- *Execute in place*: The firmware is continuously executed directly from the SPI Flash device, and the interface is constantly active.
- *Execute in internal SRAM*: The firmware is loaded into the internal SRAM of the hub and executed internally. This may only be supported if the firmware image is smaller than the SRAM size of the hub.

**Note:** All firmware images are developed, compiled, tested, and provided by Microchip. The SPI interface speed is an OTP-configurable option and only speeds that were specifically tested with the firmware image should be selected. The execution method is configured with the firmware image itself and cannot be changed via configuration.

### 7.2 Compatible SPI Flash Devices

Microchip recommends SST-brand SPI Flash devices. Microchip has verified compatibility of the following list of SPI Flash devices:

- SST26VF016B
- SST26VF032B
- SST26VF064B
- SST25VF064C
- AT25SF041
- AT26DF081

Other SPI Flash devices may be used, provided that they meet the following minimum requirements:

- Operation at 30 MHz or 60 MHz
- Mode 0 or mode 3
- Memory of 256 kB or larger
- Utilization of the same OpCode commands as with the above list of compatible devices
- Dual mode or Quad mode operation

## 7.3 SPI Connection Diagrams

If a Dual SPI Flash device is used, the recommended schematic connections are shown in [Figure 7-1](#).

**FIGURE 7-1: DUAL SPI FLASH CONNECTIONS**

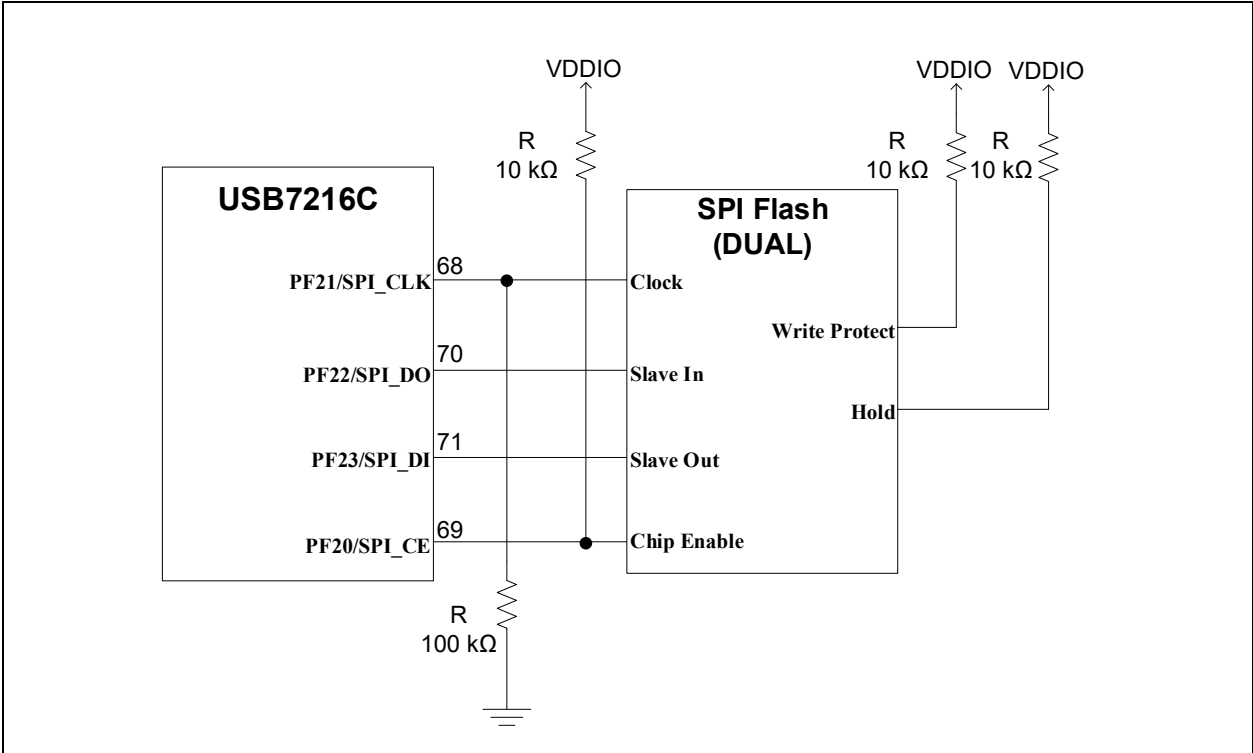

# USB7216C

If a Quad SPI Flash device is used, the recommended schematic connections are shown in [Figure 7-2](#).

**FIGURE 7-2: QUAD SPI FLASH CONNECTIONS**

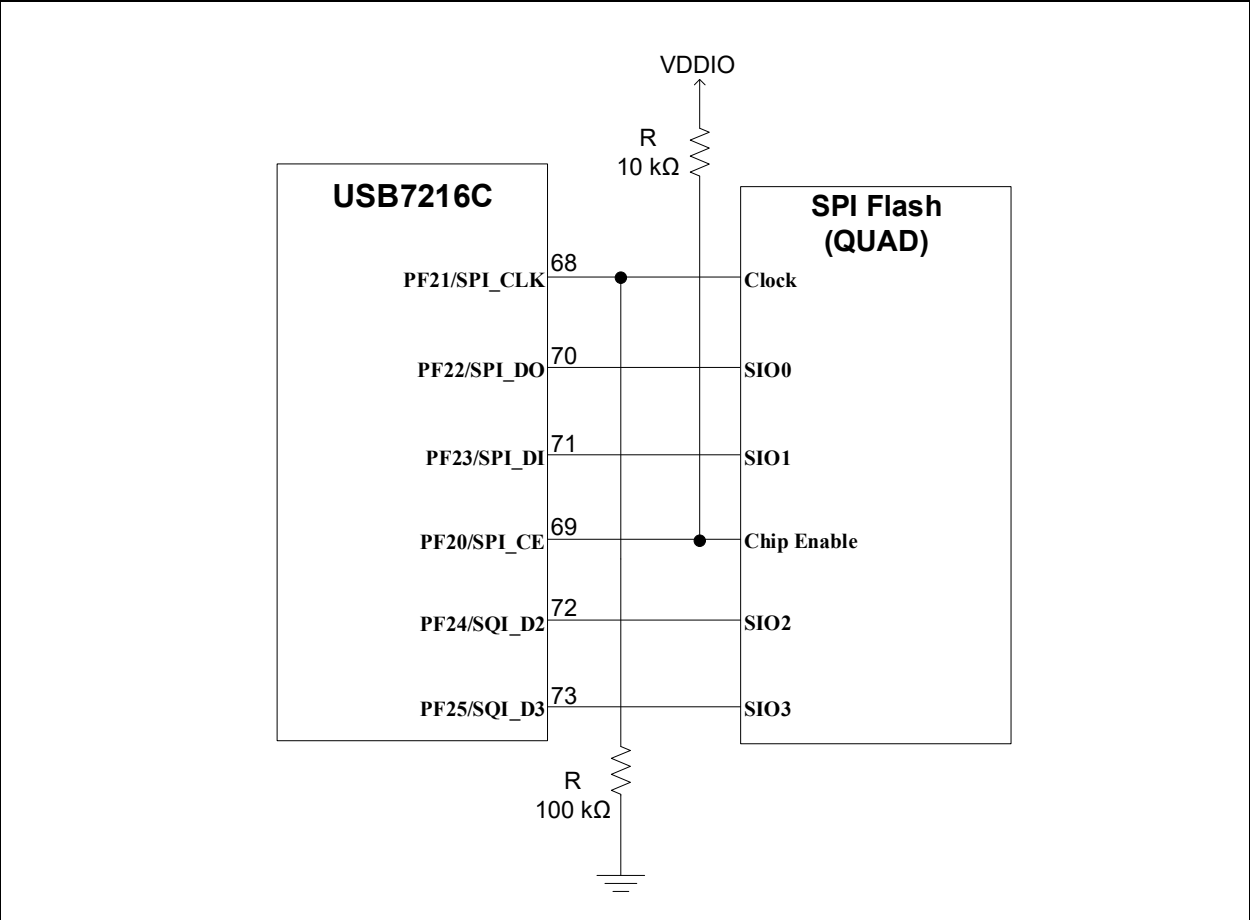

If an SPI Flash device is not used, the recommended schematic connections are shown in Figure 7-3. Some of the SPI pins become configuration straps when an SPI Flash device is not connected. A configuration strap option must be selected, and the pins cannot be floated.

**FIGURE 7-3: RECOMMENDED CONNECTIONS IF SPI FLASH IS NOT USED**

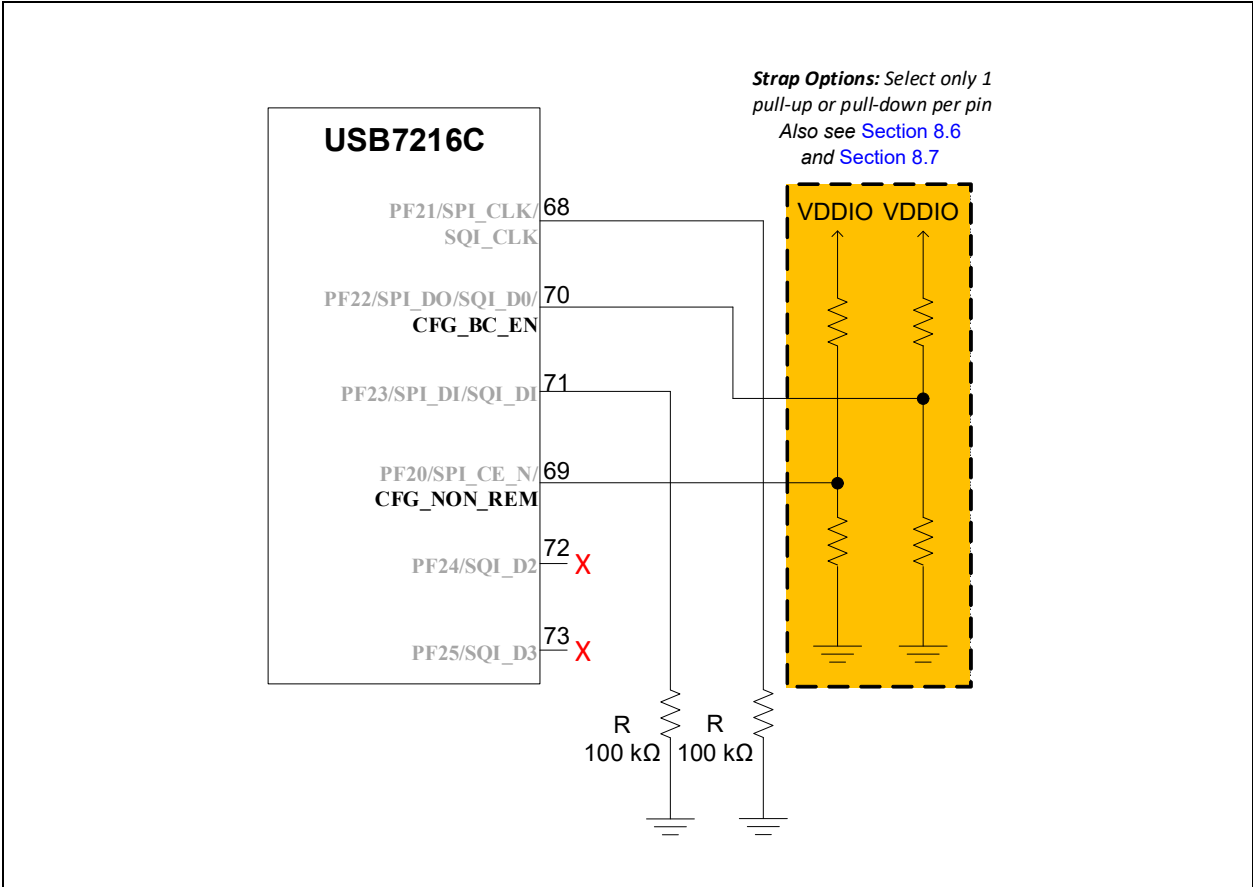

# USB7216C

## 8.0 CONFIGURATION, STRAPS, AND MISCELLANEOUS INTERFACES

### 8.1 Configuration

There are two valid configurations for the USB7216C: Config1 and Config2.

Figure 8-1 shows the required Configuration pin connections for USB7216C. CFG\_STRAP1 can be pulled up with 200 k $\Omega$ , or it can be pulled down with 200 k $\Omega$  but no other connection is permitted.

FIGURE 8-1: CONFIGURATION STRAP CONNECTIONS

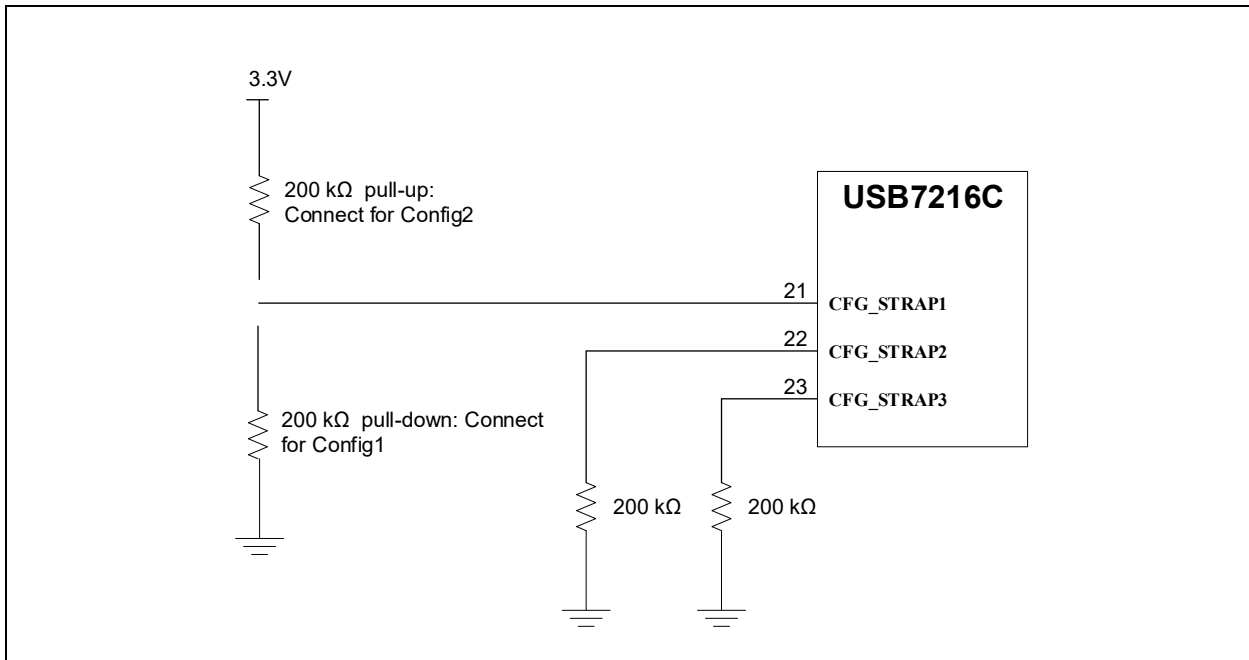

### 8.2 GPIOs

The GPIO pin included on USB7216C may be controlled from the USB host or from an embedded SoC/MCU. This GPIO can be used without any additional configuration. By default, all of the GPIOs are configured as inputs. If a default output power-on state is required, the default pin output state can be configured in the OTP memory of the hub or through the I<sup>2</sup>C/SMBus target interface during the configuration stage (SOC\_CFG). These pins are described in Table 8-1.

TABLE 8-1: AVAILABLE GPIOs

Pin	PF Pin	Name (Config1)	Name (Config2)
47	PF6	GPIO70	GPIO70
48	PF7	GPIO71	MIC_DET (I <sup>2</sup> S)
49	PF8	GPIO72	GPIO72
50	PF9	GPIO73	GPIO73
74	PF29	GPIO93	GPIO93

Instructions for operating these pins, including register definitions, are described in full in *AN2932 - USB-to-GPIO Bridging with Microchip USB72xx Hubs*.

Ensure that the voltages applied to these pins are within the electrical specifications for the pins, and that any external loading is within the drive strength capabilities as described in the *USB7216C Data Sheet*.

**Note:** Additional GPIOs may be made available for use under certain conditions or with custom firmware development. Please consult your Microchip support representative or submit a request to the Microchip online support system to discuss options.

## 8.3 I<sup>2</sup>C/SMBus Connections

There are two I<sup>2</sup>C/SMBus interfaces available on USB7216C. These are described in [Table 8-2](#).

**TABLE 8-2: I<sup>2</sup>C/SMBUS PINS**

Pin	PF Pin	Name	Role	Configuration Requirements
2	PF30	MSTR_I2C_CLK	USB-to-I <sup>2</sup> C controller clock	Config1 or Config2
3	PF31	MSTR_I2C_DATA	USB-to-I <sup>2</sup> C controller data	Config1 or Config2
75	PF26	SLV_I2C_CLK	I <sup>2</sup> C target data	Config1 only
76	PF27	SLV_I2C_DATA	I <sup>2</sup> C target clock	Config1 only

### 8.3.1 TARGET INTERFACE

- The USB7216C may be configured by an embedded SoC/MCU during both the start-up and runtime stages. Pull-up resistors must be detected by the hub at start-up in order for the I<sup>2</sup>C/SMBus interface to become active. The interface command specification and configuration register set is described in full in *AN2935 - Configuration of USB7206/USB7206C/USB7216/USB7216C/USB7252/USB7252C*.
- The target I<sup>2</sup>C/SMBus interface is only operational in Config1; the pins have different functions in Config2.
- Typically, a pull-up resistor value of 1 kΩ to 10 kΩ is sufficient, depending on the interface speed and total capacitance on the I<sup>2</sup>C tree.
- A pull-up voltage of 1.8V-3.3V is supported.

**Note:** If I<sup>2</sup>C/SMBus pull-up resistors are detected by the USB7216C at start-up, the hub waits indefinitely to be configured by the attached I<sup>2</sup>C/SMBus controller. For early prototyping, it may be necessary to physically remove the pull-up resistors until the I<sup>2</sup>C/SMBus controller is fully operational and can properly configure the hub at start-up.

### 8.3.2 CONTROLLER INTERFACE

The USB7216C has an I<sup>2</sup>C/SMBus controller interface that can bridge USB commands to I<sup>2</sup>C/SMBus. Instructions for operating the I<sup>2</sup>C/SMBus controller interface are contained in *AN3240 - USB-to-I<sup>2</sup>C Bridging with Microchip USB720x and USB725x Hubs*.

- Typically, a pull-up resistor of 1 kΩ to 10 kΩ is sufficient, depending on the configured interface speed and total capacitance on the I<sup>2</sup>C tree.
- A pull-up voltage of 1.8V to 3.3V is supported.
- Ensure that all I<sup>2</sup>C/SMBus target devices connected to the bus have unique addresses assigned.
- Ensure that the USB7216C and all I<sup>2</sup>C/SMBus target devices connected to the bus can support the target bus speed.

# USB7216C

## 8.4 I<sup>2</sup>S Connections

There is one USB-to-I<sup>2</sup>S™ interface available on USB7216C. The interface is enabled when Config2 is selected through the CFG\_STRAPx pins.

Instructions for configuring the I<sup>2</sup>S interface, including register definitions, are described in full in *AN3135 - USB-to-I<sup>2</sup>S Bridging with Microchip Hubs*.

A compatible I<sup>2</sup>S codec is required. By default, the I<sup>2</sup>S interface is configured to be connected to an ADAU1961.

Refer to [Table 8-3](#) to ensure that the selected codec is compatible with the options available on USB7216C.

**TABLE 8-3: I<sup>2</sup>S™ CODEC COMPATIBILITY GUIDE**

Parameter	Supported Values
Sampling Frequency (fs)	<ul style="list-style-type: none"><li>• 8 kHz</li><li>• 11.025 kHz</li><li>• 12 kHz</li><li>• 16 kHz</li><li>• 22.05 kHz</li><li>• 24 kHz</li><li>• 32 kHz</li><li>• 44.1 kHz</li><li>• 48 kHz</li></ul>
MCLK Frequency	1*fs to 1024*fs Since LRCLK is derived from MCLK source, the MCLK signal should be an even integer multiple of fs.
Audio Sample Size	16-bit, 24-bit, 32-bit
I <sup>2</sup> S Audio Format	I <sup>2</sup> S mode, Left Justified mode, Right Justified mode
I <sup>2</sup> C Controller Control Interface Frequency	100 kHz or 400 kHz
Audio Channels	Mono or Stereo
Interface Enable/Disable Options	Three options: <ul style="list-style-type: none"><li>• Audio OUT and Audio IN mode</li><li>• Audio OUT Only mode (Speaker Interface)</li><li>• Audio IN Only mode (Mic Interface)</li></ul>
Audio Jack Insertion Detection	Two options: <ul style="list-style-type: none"><li>• Audio Jack Insertion Detection Enabled (through HID interface)</li><li>• Audio Jack Insertion Detection Disabled</li></ul>

The I<sup>2</sup>S pins are described in [Table 8-4](#).

**TABLE 8-4: I<sup>2</sup>S™ PINS**

Pin	PF Pin	Name	Role	Configuration Requirements
48	PF7	MIC_DET	Optional - Microphone Detection Pin	Config2
51	PF10	I2S_SDI	I <sup>2</sup> S Serial Data In	Config2
77	PF28	I2S_LRCK	I <sup>2</sup> S Left Right Clock	Config2
66	PF19	I2S_SDO	I <sup>2</sup> S Serial Data Out	Config2
75	PF26	I2S_SCK	I <sup>2</sup> S Continuous Serial Clock	Config2
52	PF11	I2S_MCLK	I <sup>2</sup> S Controller Clock	Config2

If connecting to an ADAU1961, the I<sup>2</sup>S signals should be connected as shown in [Figure 8-2](#). If using a different codec, consult the design guidelines provided by the manufacturer of the selected codec for implementation guidelines.

**FIGURE 8-2: ADAU1961 I<sup>2</sup>S™ CODEC CONNECTIONS**

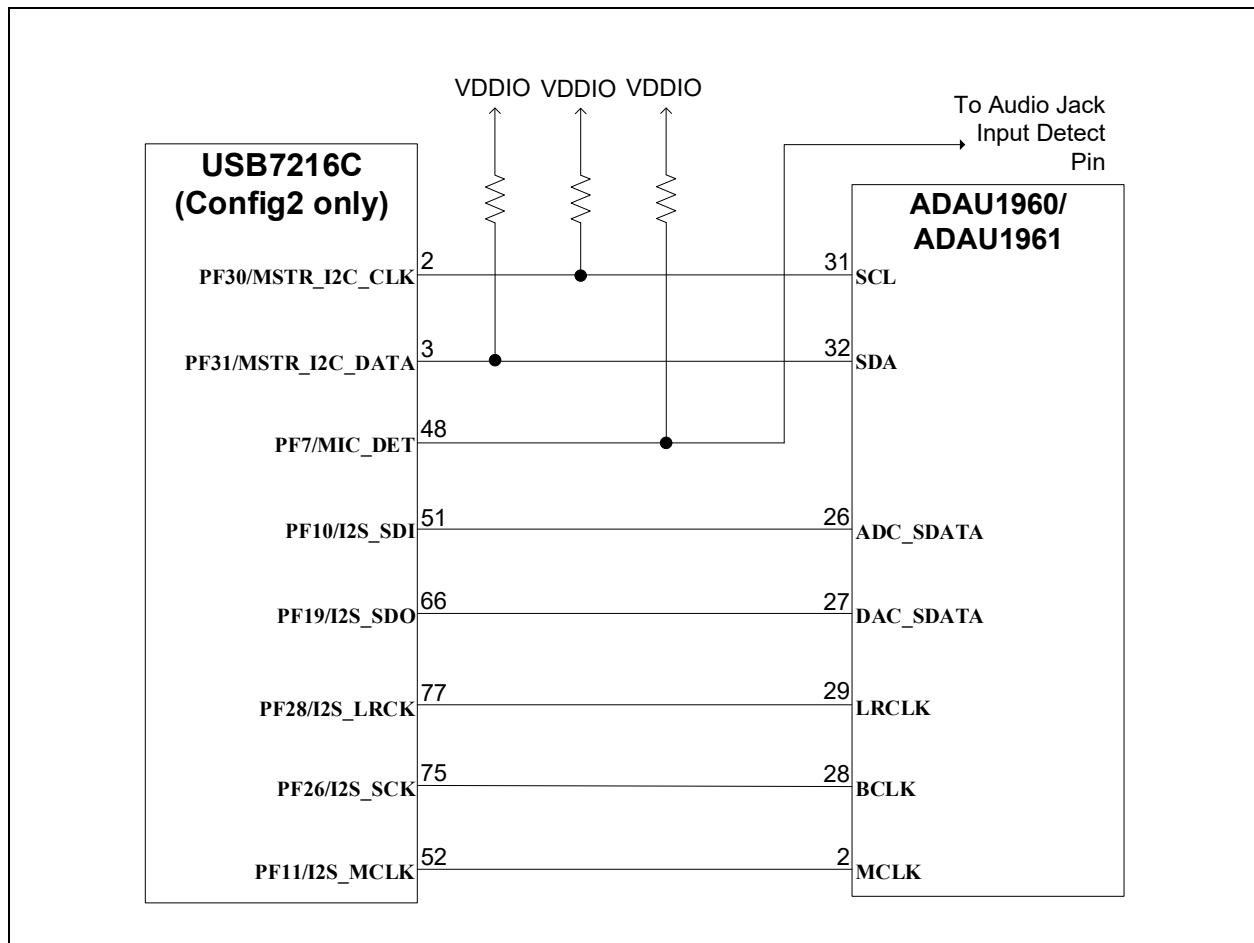

# USB7216C

## 8.5 Non-Removable Port Settings

In a typical USB7216C application, downstream port 1 is routed to a user-accessible USB connector. The downstream port should be configured as a removable port.

The USB7216C has a configuration strap option, `CFG_NON_REM`, which can be used to set the default configuration for port 1. This is located on pin 69. The strap setting is sampled once at start-up. A configuration strap option must be selected unless the hub firmware is being executed from an external SPI Flash device. These are described in [Table 8-5](#).

**TABLE 8-5: CFG\_NON\_REM**

Setting	Effect
200 k $\Omega$ pull-down to GND	All ports are removable. (Recommended for most USB7216C applications)
200 k $\Omega$ pull-up to 3.3V	Port 1 is non-removable; only a valid selection if port 1 is connected directly to an embedded USB device.
10 k $\Omega$ pull-down to GND	Ports 1 and 2 are non-removable; only a valid selection if ports 1 and 2 are connected directly to embedded USB devices.
10 k $\Omega$ pull-up to 3.3V	Ports 1, 2, and 3 are non-removable; only a valid selection if ports 1, 2, and 3 are connected directly to embedded USB devices.
10 $\Omega$ pull-down to GND	Ports 1, 2, 3, and 4 are non-removable; only a valid selection if ports 1, 2, 3, and 4 are connected directly to embedded USB devices.

The following guidelines can be used to determine which setting to use:

- If the port is routed to a user-accessible USB connector, it is *removable*.
- If the port is routed to a permanently attached an embedded USB device on the same PCB, or non-user-accessible wiring or cable harness, it is *non-removable*.

**Note:** The removable or non-removable device settings do not impact the operation of the hub in any way. The settings only modify select USB descriptors, which the USB host may use to understand if a port is a user-accessible port or if the device is a permanently attached device. Under standard operating conditions, the USB host may or may not modify its operation based upon this information. Certain USB compliance tests are impacted by this setting, so designs that must undergo USB compliance testing and certification must ensure the configuration settings are correct.

## 8.6 Self-Powered/Bus-Powered Settings

In a typical USB7216C application, the hub should be configured as self-powered, which is the default configuration setting.

The following guidelines can be used to determine which setting to use:

- If the entire system (hub included) is powered completely from the upstream USB connector's **VBUS** pin and the system is designed to operate using standard USB cabling and any standard USB host, then the hub system is *bus-powered*.
- If the entire system (hub included) is always powered by a separate power connector, then the hub system is *self-powered*.
- If the hub included is part of a larger embedded system with fixed cabling and a fixed USB host, then the hub system is most likely *self-powered* (even if all of the power is derived from the upstream USB connector's **VBUS** pin).

**Note:** The self-powered or bus-powered device settings do not impact the operation of the hub in any way. The settings only modify select USB descriptors that the USB host will use to budget power accordingly. Since a standard USB2.0 port is required to supply 500 mA to the downstream port, a bus-powered hub and all of its downstream ports must continue to operate within that 500 mA budget. A USB host will typically limit the downstream ports of a self-powered hub to 100 mA. Any device that connects to a bus-powered hub, which declares it needs more than 100 mA will be prevented from operating by the USB host.

## 8.7 Battery Charging Settings

The USB7216C hub includes built-in Dedicated Charging Port (DCP), Charging Downstream Port (CDP), and vendor-specific (SE1) battery charging support.

The USB7216C has a configuration strap option, `CFG_BC_EN`, which can be used to set the default configuration for port 1. This is located on pin 70. The strap setting is sampled once at start-up. A configuration strap option must be selected unless the hub firmware is being executed from an external SPI Flash device. The configuration strap options are described in [Table 8-6](#).

**TABLE 8-6: CFG\_BC\_EN**

Setting	Effect	Additional Notes
200 kΩ pull-down to GND	Port 1 BC disabled	<p>Battery Charging is disabled.</p> <p>Select this option if configuration will be done in hub OTP, via I<sup>2</sup>C/SMBus, or by external firmware in the SPI Flash device.</p> <p>If SE1 charging is required, this strap option should be selected and SE1 must be enabled in hub OTP, via I<sup>2</sup>C/SMBus, or by external firmware in the SPI Flash device.</p>
200 kΩ pull-up to 3.3V	Port 1 BC enabled	<p>Battery Charging is enabled.</p> <p>When no USB host is present (<code>VBUS_MON_UP = 0</code>), downstream port 1 operates in DCP mode.</p> <p>When a USB host is present (<code>VBUS_MON_UP = 1</code>) and the USB host has commanded the hub to enable port power, downstream port 1 operates in CDP mode.</p>
10 kΩ pull-down to GND	Port 1 and 2 BC enabled	<p>Battery Charging is enabled.</p> <p>When no USB host is present (<code>VBUS_MON_UP = 0</code>), downstream ports 1 and 2 operate in DCP mode.</p> <p>When a USB host is present (<code>VBUS_MON_UP = 1</code>) and the USB host has commanded the hub to enable port power, downstream ports 1 and 2 operate in CDP mode.</p>
10 kΩ pull-up to 3.3V	Port 1, 2, and 3 BC enabled	<p>Battery Charging is enabled.</p> <p>When no USB host is present (<code>VBUS_MON_UP = 0</code>), downstream ports 1, 2, and 3 operate in DCP mode.</p> <p>When a USB host is present (<code>VBUS_MON_UP = 1</code>) and the USB host has commanded the hub to enable port power, downstream ports 1, 2, and 3 operate in CDP mode.</p>
10Ω pull-down to GND	Port 1, 2, 3, and 4 BC enabled	<p>Battery Charging is enabled.</p> <p>When no USB host is present (<code>VBUS_MON_UP = 0</code>), downstream ports 1, 2, 3, and 4 operate in DCP mode.</p> <p>When a USB host is present (<code>VBUS_MON_UP = 1</code>) and the USB host has commanded the hub to enable port power, downstream ports 1, 2, 3, and 4 operate in CDP mode.</p>

# USB7216C

---

---

**Note:** The vendor-specific SE1 charging mode uses the USB data lines to communicate charging capability. Hence, SE1 can only be active when no USB host is present. Additional vendor-specific charging modes exist for charging at elevated current levels when an active data connection is also present. This is handled by a vendor-specific USB protocol between the USB host and the device. The USB7216C supports these vendor-specific protocol exchanges. These vendor-specific command specifications must be obtained from the respective device vendors.

## 9.0 HARDWARE CHECKLIST SUMMARY

TABLE 9-1: HARDWARE DESIGN CHECKLIST

Section	Subsection	Explanation	√	Notes
Section 2.0, "General Considerations"	Section 2.2, "Pin Check"	Verify that the pins match the data sheet.		
	Section 2.3, "Ground"	Verify that the ground nets are connected.		
	Section 2.4, "USB-IF Compliant USB Connectors"	Verify that USB-IF-compliant USB connectors with an assigned TID are used in the design (if USB compliance is required for the design).		
Section 3.0, "Power and Bypass Capacitance"	Section 3.0, "Power and Bypass Capacitance"	<ul style="list-style-type: none"> <li>Ensure <b>VDD33</b> is in the range 3.0V to 3.6V, and a 0.1 <math>\mu</math>F capacitor is on each pin.</li> <li>Ensure <b>VCORE</b> is in the range 1.09V to 1.21V, and a 0.1 <math>\mu</math>F capacitor is on each pin.</li> </ul>		
Section 4.0, "USB Signals and Connections"	Section 4.1, "Upstream Port USB Signals"	Verify that the USB data pins are correctly routed to the USB connectors. Pay special attention to the polarity of the USB2.0 D+ and D- data lines, and do not cross the USB3 TX and RX differential pairs. Verify that the upstream port VBUS has no more than 10 $\mu$ F capacitance and that the VBUS signal is properly divided down to a 3.3V signal and connected to the <b>VBUS_MON_UP</b> pin of the hub.		
	Section 4.2, "Downstream USB Type-C® Port 1"	Verify that the USB data pins are correctly routed to the USB connectors. Pay special attention to the polarity of the USB2.0 D+ and D- data lines, and do not cross the USB3 TX and RX differential pairs. Verify that <b>PRT_CTL1</b> is properly connected to both the Enable pin of the downstream port power controller and the Fault indicator output of the port power controller. Ensure the port power controller current capability is sized appropriately (500 mA, 900 mA, 1.5A, or 3A) and that the overcurrent threshold is set appropriately.		
	Section 4.3, "Downstream Ports 2-6"	Verify that the USB data pins are correctly routed to the USB connectors. Pay special attention to the polarity of the USB2.0 D+ and D- data lines, and do not cross the USB3 TX and RX differential pairs. Verify that <b>PRT_CTLx</b> signals are properly connected to both the Enable pins of the downstream port power controllers and the Fault indicator outputs of the port power controller. Ensure the port power controller current capability is sized appropriately (500 mA, 900 mA, 1.5A, or 3A) and that the overcurrent threshold is set appropriately.		
	Section 4.4, "Disabling Downstream Ports"	If any of the USB ports are unused, ensure they are properly disabled via pin strap. If pin strapping is not used, other methods may be used such as I <sup>2</sup> C/SMBus configuration or OTP configuration.		
	Section 4.5, "USB Protection"	Verify that ESD/EMI protection devices are designed specifically for high-speed data applications and that the combined parasitic capacitance of the protection devices, USB traces, and USB connector do not exceed 5 pF on each USB2 trace. Protection devices on USB3 traces should not add more than 0.5 pF on each line.		

TABLE 9-1: HARDWARE DESIGN CHECKLIST (CONTINUED)

Section	Subsection	Explanation	√	Notes
Section 4.0, "USB Signals and Connections"	Section 4.6, "GND and SHIELD Recommendations"	Verify that the USB connector is properly connected to PCB ground on both the <b>GND</b> pins and the <b>SHIELD</b> pins. It is recommended that an RC filter be placed in between the <b>SHIELD</b> pins and PCB ground.		
Section 5.0, "Clock Circuit"	Section 5.1, "Crystal and External Clock Connection"	Confirm the crystal or clock is 25.000 MHz ( $\pm 50$ ppm). If a single-ended external clock source is used instead of the crystal oscillator, ensure that it is connected to <b>XTALI</b> while leaving <b>XTALO</b> floating. If a crystal is used, ensure the loading capacitors are appropriately sized for the crystal loading requirement. A parallel resistor is not required.		
Section 6.0, "Power and Startup"	Section 6.1, "RBIAS Resistor"	Confirm that a 12.0 k $\Omega$ 1% resistor is connected between the <b>RBIAS</b> pin and the PCB ground.		
	Section 6.2, "Board Power Supplies"	Verify that the board power supplies deliver 3.0V-3.6V to <b>VDD33</b> and 1.09V to 1.21V to <b>VCORE</b> , and that the power-on rise time meets the requirement of the hub as defined in the data sheet. If the rise time requirement cannot be met, ensure that the <b>RESET_N</b> line is held low until the power regulators reach a steady state.		
	Section 6.3, "Reset Circuit"	Ensure that the <b>RESET_N</b> signal has an external pull-up resistor, or is otherwise properly controlled by an external SoC, MCU, or Reset supervisor device.		
Section 7.0, "External SPI Memory"	Section 7.1, "SPI Operation Summary"	Determine if a custom SPI firmware image is required and which mode of operation the selected SPI Flash device must support.		
	Section 7.2, "Compatible SPI Flash Devices"	Ensure the selected SPI Flash device is compatible with the hub.		
	Section 7.3, "SPI Connection Diagrams"	Verify that the SPI Flash device is connected according to the diagrams in <a href="#">Figure 7-1</a> or <a href="#">Figure 7-2</a> . Follow <a href="#">Figure 7-3</a> if no SPI Flash device is connected in the design.		
Section 8.0, "Configuration, Straps, and Miscellaneous Interfaces"	Section 8.1, "Configuration"	Verify that the 3 <b>CFG_STRAP</b> pins are connected according to <a href="#">Figure 8-1</a> .		
	Section 8.2, "GPIOs"	Verify that any GPIO pins that will be used as GPIOs within the application are connected properly, and never exceed the voltage maximums/minimums, or overload the current source/sink maximums as defined in the hub data sheet.		
	Section 8.3, "I <sup>2</sup> C/SMBus Connections"	If the USB-to-I <sup>2</sup> C/SMBus target interface is implemented, ensure that appropriate pull-up resistors are connected and that the connections to the I <sup>2</sup> C/SMBus controller are correct. To use the target I <sup>2</sup> C/SMBus interface, Config1 must have been selected. Note that the pull-up resistors are detected on the I <sup>2</sup> C/SMBus target interface, the USB hub will not enumerate to a USB host until it receives the special "Attach" command from the I <sup>2</sup> C/SMBus controller.		

**TABLE 9-1: HARDWARE DESIGN CHECKLIST (CONTINUED)**

Section	Subsection	Explanation	√	Notes
	<a href="#">Section 8.4, "I2S Connections"</a>	If using the USB-to-I <sup>2</sup> S™ bridge feature, ensure that Config2 is selected via the CFG_STRAP pin, and ensure that the pin connections to the I <sup>2</sup> S codec are correct. If using any codec other than the ADAU1961, ensure that it is compatible by referencing the compatibility guide in <a href="#">Table 8-1</a> .		
	<a href="#">Section 8.5, "Non-Removable Port Settings"</a>	Verify that the CFG_NON_REM configuration strap is set per application requirements. Most USB7216C applications should set this strap to the 'Port 1 Removable' setting.		
	<a href="#">Section 8.6, "Self-Powered/Bus-Powered Settings"</a>	Verify the application requirements for self-powered or bus-powered operation. If self-powered operation is required, then no additional configuration or circuitry is required. If bus-powered operation is required, then the hub must be configured via OTP or I <sup>2</sup> C/SMBus.		
	<a href="#">Section 8.7, "Battery Charging Settings"</a>	Verify that the CFG_BC_EN configuration strap is set per application requirements. Most USB7216C applications should set this strap to the 'Port 1 BC Enable' setting.		

# USB7216C

## APPENDIX A: REVISION HISTORY

TABLE A-1: REVISION HISTORY

Revision Level & Date	Section/Figure/Entry	Correction
DS00003286C (12-13-24)	Section 4.1, "Upstream Port USB Signals"	Updated pin descriptions.
	Figure 4-1	Added a 0.33 $\mu$ F capacitor to RX lines.
	Figure 4-2	Added a 0.33 $\mu$ F capacitor to RX lines.
	Figure 4-3	Added a 0.33 $\mu$ F capacitor to RX lines.
	Figure 4-4	Added a 0.33 $\mu$ F capacitor to RX lines.
	Figure 4-9	Added a 0.33 $\mu$ F capacitor to RX lines.
	Note	Revised the last three sentences to change the term "self-powered" to "bus-powered."
	Section 4.3.1, "Downstream Type-A USB Signals"	Changed "PRT_CTLx and DPx_VBUS_MON can be shorted together and connected directly to the Enable signal..." to "PRT_CTLx can be connected directly to the Enable signal..."
All	Added "C" to the part number, USB7216. Changed occurrences of "VBUS_DET" to "VBUS_MON_UP." Made minor formatting updates	
DS00003286B (10-11-22)	Section 2.1, "Required References"	Updated the references.
	Section 2.3, "Ground"	Updated the ground pin name to VSS.
	Figure 3-1	Updated the figure.
	Section 4.1, "Upstream Port USB Signals"	Replaced USB3.1 instances with USB3.2. Updated all the figures in the section. Added upstream port to Type-C connection information and <a href="#">Figure 4-3</a> .
	Section 4.2, "Downstream USB Type-C <sup>®</sup> Port 1"	Updated most of the pin names and replaced instance of USB3.1 with USB3.2. Also updated most of the figures in the section.
	Section 4.3, "Downstream Ports 2-6"	Updated the pin numbers and replaced instances of USB3.1 with USB3.2. Also updated some of the figures in the section.
	Section 4.6, "GND and SHIELD Recommendations"	Replaced mention of EARTH with SHIELD.
	All	Mentions of master and slave replace with controller and target, respectively.
	Section 9.0, "Hardware Checklist Summary"	Replaced mention of VBUS_DET with VBUS_MON_UP.
DS00003286A (10-28-19)	Initial release	

NOTES:

---

---

## Microchip Information

### Trademarks

The “Microchip” name and logo, the “M” logo, and other names, logos, and brands are registered and unregistered trademarks of Microchip Technology Incorporated or its affiliates and/or subsidiaries in the United States and/or other countries (“Microchip Trademarks”). Information regarding Microchip Trademarks can be found at <https://www.microchip.com/en-us/about/legalinformation/microchip-trademarks>.

ISBN: 979-8-3371-0297-9

### Legal Notice

This publication and the information herein may be used only with Microchip products, including to design, test, and integrate Microchip products with your application. Use of this information in any other manner violates these terms. Information regarding device applications is provided only for your convenience and may be superseded by updates. It is your responsibility to ensure that your application meets with your specifications. Contact your local Microchip sales office for additional support or, obtain additional support at [www.microchip.com/en-us/support/design-help/client-support-services](http://www.microchip.com/en-us/support/design-help/client-support-services).

THIS INFORMATION IS PROVIDED BY MICROCHIP "AS IS". MICROCHIP MAKES NO REPRESENTATIONS OR WARRANTIES OF ANY KIND WHETHER EXPRESS OR IMPLIED, WRITTEN OR ORAL, STATUTORY OR OTHERWISE, RELATED TO THE INFORMATION INCLUDING BUT NOT LIMITED TO ANY IMPLIED WARRANTIES OF NON-INFRINGEMENT, MERCHANTABILITY, AND FITNESS FOR A PARTICULAR PURPOSE, OR WARRANTIES RELATED TO ITS CONDITION, QUALITY, OR PERFORMANCE.

IN NO EVENT WILL MICROCHIP BE LIABLE FOR ANY INDIRECT, SPECIAL, PUNITIVE, INCIDENTAL, OR CONSEQUENTIAL LOSS, DAMAGE, COST, OR EXPENSE OF ANY KIND WHATSOEVER RELATED TO THE INFORMATION OR ITS USE, HOWEVER CAUSED, EVEN IF MICROCHIP HAS BEEN ADVISED OF THE POSSIBILITY OR THE DAMAGES ARE FORESEEABLE. TO THE FULLEST EXTENT ALLOWED BY LAW, MICROCHIP'S TOTAL LIABILITY ON ALL CLAIMS IN ANY WAY RELATED TO THE INFORMATION OR ITS USE WILL NOT EXCEED THE AMOUNT OF FEES, IF ANY, THAT YOU HAVE PAID DIRECTLY TO MICROCHIP FOR THE INFORMATION.

Use of Microchip devices in life support and/or safety applications is entirely at the buyer's risk, and the buyer agrees to defend, indemnify and hold harmless Microchip from any and all damages, claims, suits, or expenses resulting from such use. No licenses are conveyed, implicitly or otherwise, under any Microchip intellectual property rights unless otherwise stated.

### Microchip Devices Code Protection Feature

Note the following details of the code protection feature on Microchip products:

- Microchip products meet the specifications contained in their particular Microchip Data Sheet.
- Microchip believes that its family of products is secure when used in the intended manner, within operating specifications, and under normal conditions.
- Microchip values and aggressively protects its intellectual property rights. Attempts to breach the code protection features of Microchip product is strictly prohibited and may violate the Digital Millennium Copyright Act.
- Neither Microchip nor any other semiconductor manufacturer can guarantee the security of its code. Code protection does not mean that we are guaranteeing the product is “unbreakable”. Code protection is constantly evolving. Microchip is committed to continuously improving the code protection features of our products.