



MIC4811 Evaluation Board

High Current 6 Channel Linear WLED Driver with DAM™ and Ultra Fast PWM™ Control

General Description

The MIC4811 is a high efficiency linear White LED (WLED) driver; it is designed to drive up to six high current WLEDs while maintaining constant current in each channel. The MIC4811 features Dynamic Average Matching™ (DAM™) which is specifically designed to provide optimum matching across all WLEDs. These high accuracy ($\pm 1\%$ typical) current regulated WLED channels ensure uniform display illumination under all conditions. A typical dropout of 100mV at 50mA is expected.

The MIC4811 is available in a 10-pin MSOP package with a junction temperature range of -40°C to $+125^{\circ}\text{C}$.

Datasheets and support documentation can be found on Micrel's web site at: www.micrel.com

Requirements

The MIC4811 evaluation board requires a power supply that is capable of delivering at least 1A while providing an input voltage between 3.0V and 5.5V.

Precautions

The MIC4811 evaluation board is designed for an input voltage no greater than 6V. This evaluation board does not have reverse polarity protection; hence, applying a negative voltage to the V_{IN} terminal may damage the device.

Getting Started

- 1. Connect an external supply to V_{IN} .** Apply the desired input voltage across V_{IN} and ground terminals, J1 and J2, respectively, paying careful attention to polarity and supply voltage ($3.0\text{V} \leq V_{IN} \leq 5.5\text{V}$). An ammeter may be placed between the input supply and the V_{IN} terminal to the evaluation board. Ensure that the supply voltage is monitored at the V_{IN} terminal. The ammeter and/or power lead resistance can reduce the voltage supplied to the input.

2. Enable/Disable the MIC4811

To enable the device, apply a DC voltage of 1.2V or greater to the EN pin (J3). This allows for full brightness of the WLEDs (100% duty cycle). The EN pin can also be used for dimming by connecting a PWM signal and varying its duty cycle (please refer to the Ultra Fast PWM™ Dimming Interface Section in datasheet). Pulling EN low for more than 20ms forces the MIC4811 into a low I_Q sleep mode. Do not leave the EN pin floating as this may cause an indeterminate output state. A pull down resistor of 200k Ω is placed from EN to GND to ensure that the WLEDs are OFF when an enable signal is not applied.

3. Setting LED current with R_{SET} resistor.

The average LED current may be calculated using the equation below:

$$R_{SET} (k\Omega) = \frac{820 \cdot D}{I_{LED} (mA)} + 0.139$$

$$I_{LED} (mA) = \frac{820 \cdot D}{(R_{SET} (k\Omega) - 0.139)}$$

D is the duty cycle of the LED current during PWM dimming; $D=1$ when device is fully ON. The stock evaluation board uses an R_{SET} value of 16.5k Ω which corresponds to I_{LED} of 50mA.

4. Measuring WLED current.

To measure WLED current, simply insert an ammeter in series with the WLED(s). Keep in mind that a series ammeter will add a small voltage drop, so the voltage at the WLED terminal(s), D1-D6, should be used when making dropout measurements with a series ammeter.

Ordering Information

Part Number	Description
MIC4811YMM EV	Evaluation board with Six Channel WLED Driver

Ultra Fast PWM and DAM™ Dynamic Average Matching are trademarks of Micrel, Inc.

Micrel Inc. • 2180 Fortune Drive • San Jose, CA 95131 • USA • tel +1 (408) 944-0800 • fax + 1 (408) 474-1000 • <http://www.micrel.com>

MIC4811 Evaluation Board Schematic

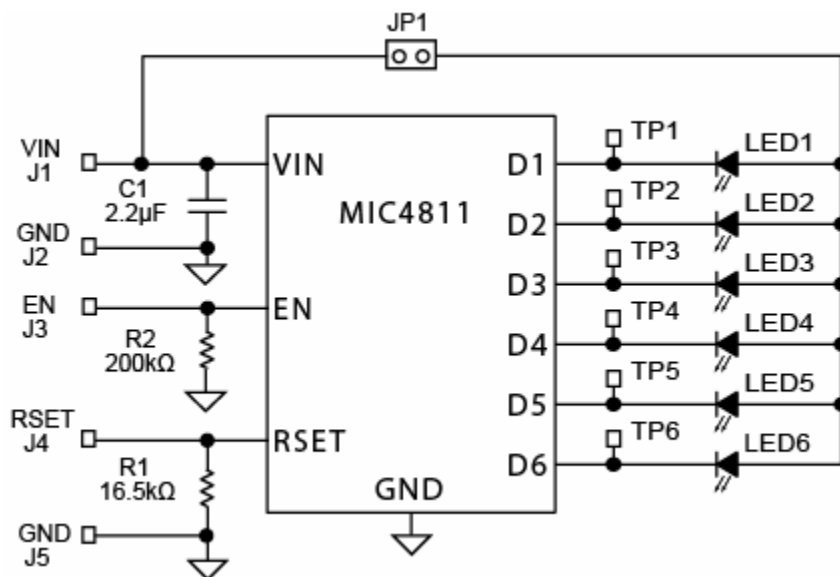

Bill of Materials

Item	Part Number	Manufacturer	Description	Qty
C1	C1608X5R0J225K	TDK ⁽¹⁾	Ceramic Capacitor, 2.2µF, 6.3V, X5R, Size 0603	1
	06036D225KAT2A	AVX ⁽²⁾		
	GRM188R60J225KE19D	Murata ⁽³⁾		
	VJ0603G225KXYAT	Vishay ⁽⁴⁾		
LED1– LED6	OVS5WBCR4	OPTEK Technology, Inc ⁽⁵⁾	WLED	6
R1	CRCW060316K55F5EA	Vishay ⁽⁴⁾	Resistor, 16.5, 1%, 1/16W, Size 0603	1
R2	CRCW06032003FKEA	Vishay ⁽⁴⁾	Resistor, 200k, 1%, 1/16W, Size 0603	1
U1	MIC4811YMM	Micrel, Inc. ⁽⁶⁾	High Current 6 Channel Linear WLED Driver with DAM™ and Ultra Fast PWM™ Control	1

Notes:

1. TDK: www.tdk.com
2. AVX: www.avx.com
3. Murata: www.murata.com
4. Vishay: www.vishay.com
5. OPTEK: www.optekinc.com
6. Micrel, Inc.: www.micrel.com

PCB Layout Recommendations

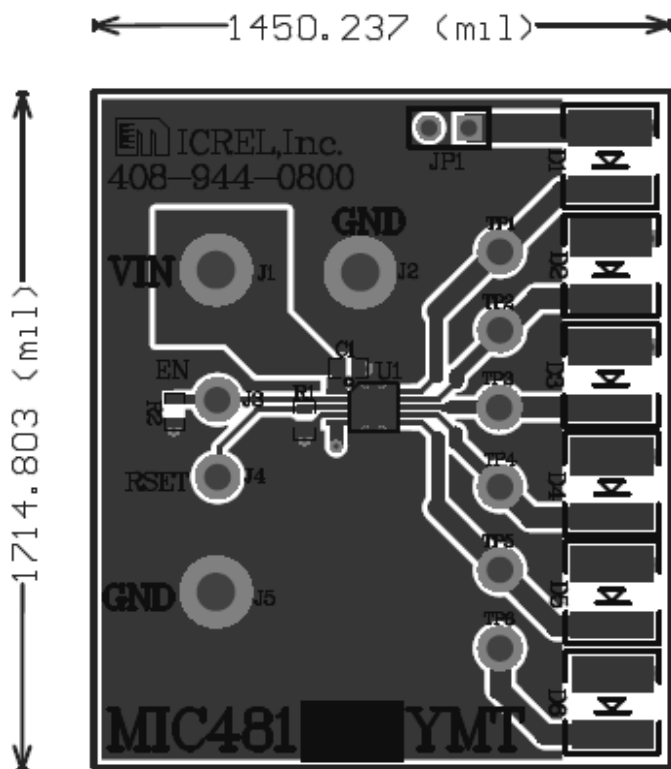

Top Layer

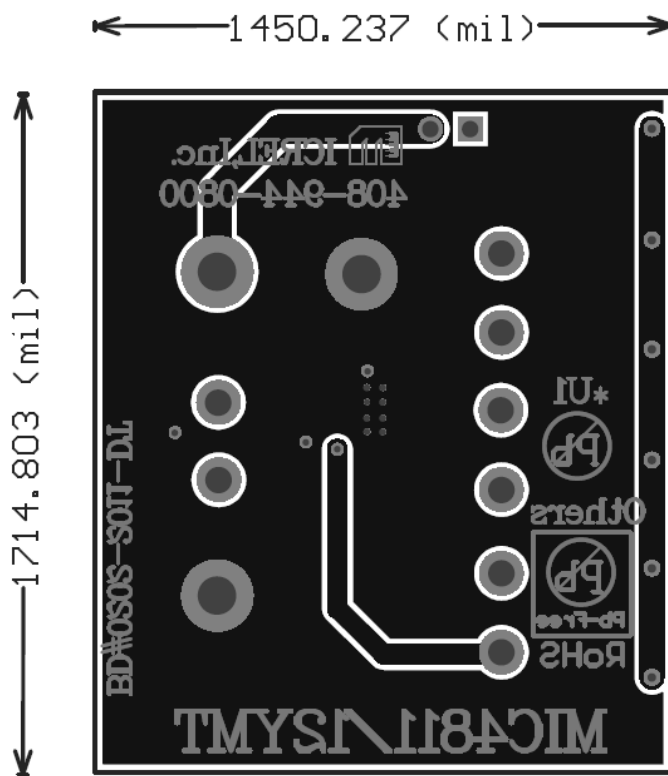

Bottom Layer

Package Information

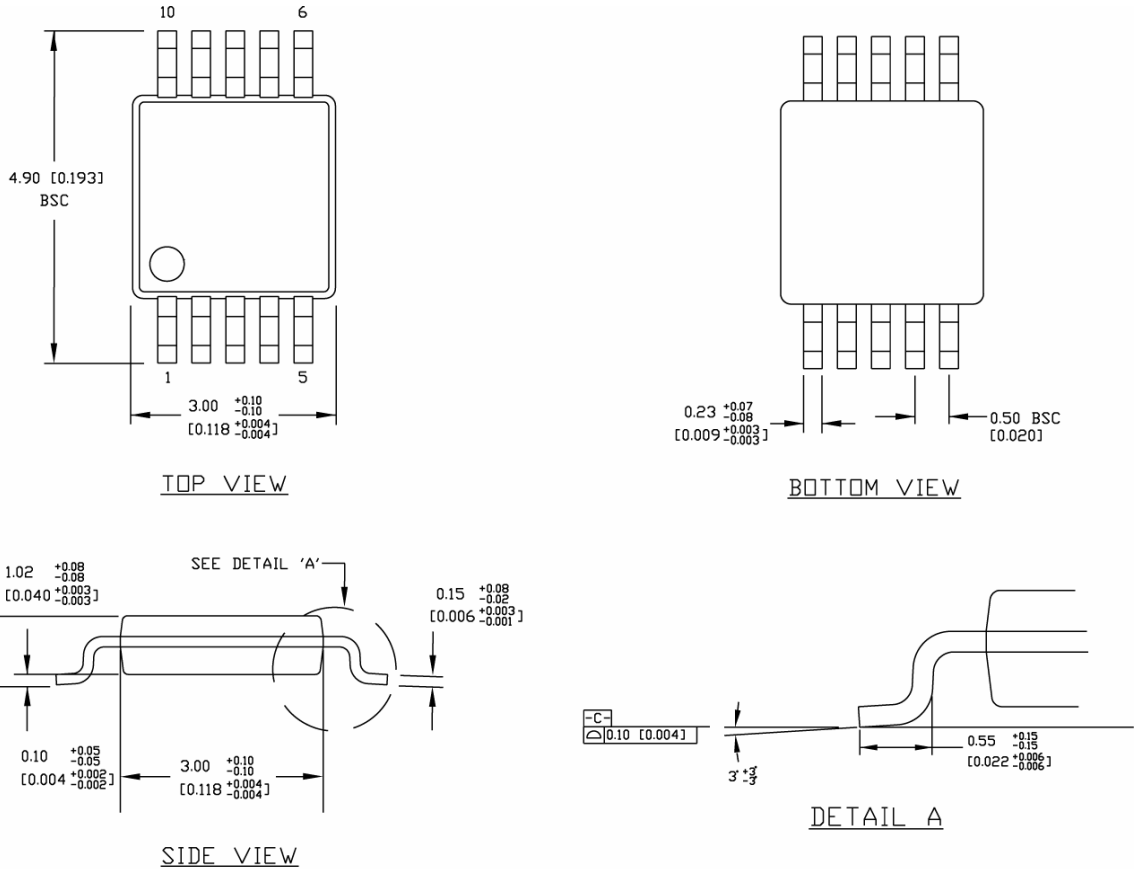

- NOTES:**
1. DIMENSIONS ARE IN MM [INCHES].
 2. CONTROLLING DIMENSION: MM
 3. DIMENSION DOES NOT INCLUDE MOLD FLASH OR PROTRUSIONS, EITHER OF WHICH SHALL NOT EXCEED 0.20 [0.008] PER SIDE.

10-Pin MSOP (MM)

MICREL, INC. 2180 FORTUNE DRIVE SAN JOSE, CA 95131 USA
 TEL +1 (408) 944-0800 FAX +1 (408) 474-1000 WEB <http://www.micrel.com>

Micrel makes no representations or warranties with respect to the accuracy or completeness of the information furnished in this data sheet. This information is not intended as a warranty and Micrel does not assume responsibility for its use. Micrel reserves the right to change circuitry, specifications and descriptions at any time without notice. No license, whether express, implied, arising by estoppel or otherwise, to any intellectual property rights is granted by this document. Except as provided in Micrel's terms and conditions of sale for such products, Micrel assumes no liability whatsoever, and Micrel disclaims any express or implied warranty relating to the sale and/or use of Micrel products including liability or warranties relating to fitness for a particular purpose, merchantability, or infringement of any patent, copyright or other intellectual property right.

Micrel Products are not designed or authorized for use as components in life support appliances, devices or systems where malfunction of a product can reasonably be expected to result in personal injury. Life support devices or systems are devices or systems that (a) are intended for surgical implant into the body or (b) support or sustain life, and whose failure to perform can be reasonably expected to result in a significant injury to the user. A Purchaser's use or sale of Micrel Products for use in life support appliances, devices or systems is a Purchaser's own risk and Purchaser agrees to fully indemnify Micrel for any damages resulting from such use or sale.