

**VSC8541-01 Datasheet**  
**Single Port Gigabit Ethernet Copper PHY with**  
**GMII/RGMII/MII/RMII Interfaces**



---

a  MICROCHIP company



**Microsemi Headquarters**

One Enterprise, Aliso Viejo,  
CA 92656 USA

Within the USA: +1 (800) 713-4113

Outside the USA: +1 (949) 380-6100

Sales: +1 (949) 380-6136

Fax: +1 (949) 215-4996

Email: [sales.support@microsemi.com](mailto:sales.support@microsemi.com)

[www.microsemi.com](http://www.microsemi.com)

©2018 Microsemi, a wholly owned subsidiary of Microchip Technology Inc. All rights reserved. Microsemi and the Microsemi logo are registered trademarks of Microsemi Corporation. All other trademarks and service marks are the property of their respective owners.

Microsemi makes no warranty, representation, or guarantee regarding the information contained herein or the suitability of its products and services for any particular purpose, nor does Microsemi assume any liability whatsoever arising out of the application or use of any product or circuit. The products sold hereunder and any other products sold by Microsemi have been subject to limited testing and should not be used in conjunction with mission-critical equipment or applications. Any performance specifications are believed to be reliable but are not verified, and Buyer must conduct and complete all performance and other testing of the products, alone and together with, or installed in, any end-products. Buyer shall not rely on any data and performance specifications or parameters provided by Microsemi. It is the Buyer's responsibility to independently determine suitability of any products and to test and verify the same. The information provided by Microsemi hereunder is provided "as is, where is" and with all faults, and the entire risk associated with such information is entirely with the Buyer. Microsemi does not grant, explicitly or implicitly, to any party any patent rights, licenses, or any other IP rights, whether with regard to such information itself or anything described by such information. Information provided in this document is proprietary to Microsemi, and Microsemi reserves the right to make any changes to the information in this document or to any products and services at any time without notice.

**About Microsemi**

Microsemi, a wholly owned subsidiary of Microchip Technology Inc. (Nasdaq: MCHP), offers a comprehensive portfolio of semiconductor and system solutions for aerospace & defense, communications, data center and industrial markets. Products include high-performance and radiation-hardened analog mixed-signal integrated circuits, FPGAs, SoCs and ASICs; power management products; timing and synchronization devices and precise time solutions, setting the world's standard for time; voice processing devices; RF solutions; discrete components; enterprise storage and communication solutions, security technologies and scalable anti-tamper products; Ethernet solutions; Power-over-Ethernet ICs and midspans; as well as custom design capabilities and services. Learn more at [www.microsemi.com](http://www.microsemi.com).

# Contents

<b>1</b>	<b>Revision History</b>	<b>1</b>
1.1	Revision 4.2	1
1.2	Revision 4.1	1
1.3	Revision 4.0	1
<b>2</b>	<b>Overview</b>	<b>2</b>
2.1	Key Features	2
2.1.1	Superior PHY and Interface Technology	2
2.1.2	Synchronous Ethernet and IEEE 1588 Time Stamp Support	2
2.1.3	Fast Link Up/Link Drop Modes	3
2.1.4	Best-in-Class Power Consumption	3
2.1.5	Key Specifications	3
2.2	Block Diagram	3
<b>3</b>	<b>Functional Descriptions</b>	<b>4</b>
3.1	Operating Modes	4
3.2	MAC Interface	4
3.2.1	RGMII MAC Interface Mode	4
3.2.2	GMII/MII Interface Mode	5
3.2.3	RMII Mode	6
3.2.4	MAC Interface Edge Rate Control	7
3.3	Hardware Mode Strapping and PHY Addressing	8
3.3.1	CLKOUT Signal Configuration	9
3.3.2	Managed Mode	9
3.3.3	Unmanaged Mode	9
3.3.4	GMII/MII or RGMII/RMII MAC Interface Mode	11
3.3.5	CLKOUT Frequency Selection	11
3.3.6	Forced 100BASE-T Mode	11
3.4	Cat5 Twisted Pair Media Interface	11
3.4.1	Voltage Mode Line Driver	11
3.4.2	Cat5 Auto-Negotiation and Parallel Detection	12
3.4.3	Automatic Crossover and Polarity Detection	12
3.4.4	Manual MDI/MDIX Setting	13
3.4.5	Link Speed Downshift	13
3.4.6	Energy-Efficient Ethernet	13
3.4.7	Ring Resiliency	14
3.5	Reference Clock	14
3.6	Ethernet Inline-Powered Devices	15
3.7	IEEE 802.3af Power-over-Ethernet Support	17
3.8	ActiPHY Power Management	17
3.8.1	Low Power State	18
3.8.2	Link Partner Wake-Up State	18
3.8.3	Normal Operating State	18
3.9	Media Recovered Clock Output	18
3.9.1	Clock Output Squelch	18
3.10	Serial Management Interface	18
3.10.1	SMI Frames	19
3.10.2	SMI Interrupt	20
3.11	LED Interface	20
3.11.1	LED Modes	20
3.11.2	Basic Serial LED Mode	21

3.11.3	Extended LED Modes	22
3.11.4	LED Behavior	22
3.12	Wake-On-LAN and SecureOn	23
3.13	Fast Link Failure Indication	24
3.14	Fast Link Failure 2™ (FLF2™) Indication	24
3.15	Start of Frame (SOF) Indication (VSC8541-04 Only)	24
3.16	Forced Speed Mode Link-Up Timing	25
3.17	Testing Features	25
3.17.1	Ethernet Packet Generator	25
3.17.2	Far-End Loopback	26
3.17.3	Near-End Loopback	26
3.17.4	Connector Loopback	26
3.17.5	VeriPHY Cable Diagnostics	27
3.18	Configuration	27
3.18.1	Managed Applications	27
3.18.2	Unmanaged Applications	27
3.18.3	Initialization	28
<b>4</b>	<b>Registers</b>	<b>29</b>
4.1	Register and Bit Conventions	29
4.2	IEEE 802.3 and Main Registers	30
4.2.1	Mode Control	31
4.2.2	Mode Status	32
4.2.3	Device Identification	32
4.2.4	Auto-Negotiation Advertisement	33
4.2.5	Link Partner Auto-Negotiation Capability	33
4.2.6	Auto-Negotiation Expansion	34
4.2.7	Transmit Auto-Negotiation Next Page	34
4.2.8	Auto-Negotiation Link Partner Next Page Receive	34
4.2.9	1000BASE-T Control	35
4.2.10	1000BASE-T Status	35
4.2.11	MMD Access Control Register	36
4.2.12	MMD Address or Data Register	36
4.2.13	1000BASE-T Status Extension 1	36
4.2.14	100BASE-TX Status Extension	36
4.2.15	1000BASE-T Status Extension 2	37
4.2.16	Bypass Control	38
4.2.17	Error Counter 1	38
4.2.18	Error Counter 2	39
4.2.19	Error Counter 3	39
4.2.20	Extended Control and Status	39
4.2.21	Extended PHY Control 1	40
4.2.22	Extended PHY Control 2	41
4.2.23	Interrupt Mask	41
4.2.24	Interrupt Status	42
4.2.25	Device Auxiliary Control and Status	43
4.2.26	LED Mode Select	43
4.2.27	LED Behavior	44
4.2.28	Extended Page Access	44
4.3	Extended Page 1 Registers	45
4.3.1	Cu Media CRC Good Counter	45
4.3.2	Extended Mode Control	46
4.3.3	ActiPHY Control	46
4.3.4	PoE and Miscellaneous Functionality	47
4.3.5	Ethernet Packet Generator (EPG) Control 1	48
4.3.6	Ethernet Packet Generator Control 2	48
4.4	Extended Page 2 Registers	49

4.4.1	Cu PMD Transmit Control	49
4.4.2	EEE Control	51
4.4.3	RGMII Control	52
4.4.4	Wake-on-LAN MAC Address [15:0]	54
4.4.5	Wake-on-LAN MAC Address [31:16]	54
4.4.6	Wake-on-LAN MAC Address [47:32]	54
4.4.7	Secure-On Password [15:0]	54
4.4.8	Secure-On Password [31:16]	55
4.4.9	Secure-On Password [47:32]	55
4.4.10	Wake-on-LAN and MAC Interface Control	55
4.4.11	Extended Interrupt Mask	56
4.4.12	Extended Interrupt Status	56
4.4.13	Ring Resiliency Control	57
4.5	General Purpose Registers	57
4.5.1	CLKOUT Control	58
4.5.2	GPIO Control 2	58
4.5.3	Fast Link Configuration	59
4.5.4	Recovered Clock Control	59
4.5.5	Enhanced LED Control	60
4.6	Clause 45 Registers to Support Energy-Efficient Ethernet and 802.3bf	60
4.6.1	PMA/PMD Status 1	60
4.6.2	PCS Status 1	61
4.6.3	EEE Capability	61
4.6.4	EEE Wake Error Counter	61
4.6.5	EEE Advertisement	62
4.6.6	EEE Link Partner Advertisement	62
4.6.7	802.3bf Registers	62
<b>5</b>	<b>Electrical Specifications</b>	<b>63</b>
5.1	DC Characteristics	63
5.1.1	VDDMAC, VDDIO, and VDDMDIO (2.5 V)	63
5.1.2	VDDMAC, VDDIO, and VDDMDIO (3.3 V)	63
5.1.3	VDDMAC and VDDMDIO (1.5 V)	64
5.1.4	VDDMAC and VDDMDIO (1.8 V)	64
5.1.5	VDDMDIO (1.2 V)	64
5.1.6	XTAL1	65
5.1.7	LED	65
5.1.8	Internal Pull-Up or Pull-Down Resistors	65
5.1.9	Current Consumption	66
5.1.10	Thermal Diode	67
5.2	AC Characteristics	67
5.2.1	Reference Clock	67
5.2.2	Recovered Clock	68
5.2.3	CLKOUT	69
5.2.4	RMII_CLKOUT	69
5.2.5	Basic Serial LEDs	70
5.2.6	RMII AC Characteristics	70
5.2.7	GMII Transmit	70
5.2.8	GMII Receive	71
5.2.9	MII Transmit	72
5.2.10	MII Receive	72
5.2.11	Uncompensated RGMII	73
5.2.12	Compensated RGMII	74
5.2.13	Start of Frame Indication	75
5.2.14	Serial Management Interface	76
5.2.15	Reset Timing	77
5.3	Operating Conditions	77

5.4	Stress Ratings .....	78
<b>6</b>	<b>Pin Descriptions .....</b>	<b>79</b>
6.1	Pin Identifications .....	79
6.2	Pin Diagram .....	80
6.3	Pins by Function .....	80
<b>7</b>	<b>Package Information .....</b>	<b>85</b>
7.1	Package Drawing .....	85
7.2	Thermal Specifications .....	86
7.3	Moisture Sensitivity .....	87
<b>8</b>	<b>Design Considerations .....</b>	<b>88</b>
8.1	Link status LED remains on while COMA_MODE pin is asserted high .....	88
8.2	Forced 1000BASE-T mode blocks some SMI register writes .....	88
8.3	Forced 1000BASE-T mode incorrectly reports interrupt status and PCS status counters .....	88
8.4	10BASE-T signal amplitude .....	88
8.5	Receive error counter only clears when NRESET applied in RMI mode .....	88
8.6	Anomalous PCS error indications in Energy Efficient Ethernet mode .....	89
8.7	10BASE-T half-duplex linkup after initial reset from power up .....	89
8.8	RGMII interface may not generate even count of preamble nibbles at 10 Mbps .....	89
8.9	Long link up times while in forced 100BASE-TX mode .....	89
8.10	Long link up times for 100BASE-TX parallel detection .....	89
<b>9</b>	<b>Ordering Information .....</b>	<b>90</b>

# Figures

Figure 1	Application Diagram	2
Figure 2	Block Diagram	3
Figure 3	RGMII MAC Interface	5
Figure 4	GMII/MII MAC Interface	5
Figure 5	RMII MAC Interface	6
Figure 6	Mode 1	7
Figure 7	Mode 2	7
Figure 8	Cat5 Media Interface	12
Figure 9	Low Power Idle Operation	13
Figure 10	XTAL Reference Clock	14
Figure 11	External 3.3 V Reference Clock	15
Figure 12	Inline-Powered Ethernet Switch Diagram	16
Figure 13	ActiPHY State Diagram	17
Figure 14	SMI Read Frame	19
Figure 15	SMI Write Frame	19
Figure 16	MDINT Configured as an Open-Drain (Active-Low) Pin	20
Figure 17	Wake-on-LAN Functionality	23
Figure 18	SOF Indication	25
Figure 19	Far-End Loopback Diagram	26
Figure 20	Near-End Loopback Diagram	26
Figure 21	Connector Loopback Diagram	26
Figure 22	Register Space Diagram	29
Figure 23	Thermal Diode	67
Figure 24	Test Circuit for Recovered Clock Outputs Signal	69
Figure 25	Basic Serial LED Timing	70
Figure 26	GMII Transmit Timing	71
Figure 27	GMII Receive Timing	72
Figure 28	MII Transmit Timing	72
Figure 29	MII Receive Timing	73
Figure 30	Uncompensated RGMII Timing	74
Figure 31	Compensated Input RGMII Timing	75
Figure 32	Compensated Output RGMII Timing	75
Figure 33	SOF Indication Timing	76
Figure 34	Serial Management Interface Timing	77
Figure 35	Pin Diagram	80
Figure 36	Package Drawing	86

# Tables

Table 1	Operating Modes	4
Table 2	Recommended Values for $R_S$ ( $\pm 5\%$ )	4
Table 3	RMII Pin Allocation	6
Table 4	Recommended Edge Rate Settings	7
Table 5	MAC Interface Edge Rate Control	8
Table 6	Hardware Mode Strapping and PHY Addressing	8
Table 7	Managed Mode	9
Table 8	Signals A and B	10
Table 9	Signals C and D	10
Table 10	CLKOUT Frequency Selection	11
Table 11	Supported MDI Pair Combinations	13
Table 12	REFCLK Frequency Selection	14
Table 13	LED Drive State	20
Table 14	LED Mode and Function Summary	21
Table 15	LED Serial Bitstream Order	22
Table 16	Extended LED Mode and Function Summary	22
Table 17	SOF Indication	25
Table 18	Forced Speed Mode Link-Up Timing	25
Table 19	IEEE 802.3 Registers	30
Table 20	Main Registers	30
Table 21	Mode Control, Address 0 (0x00)	31
Table 22	Mode Status, Address 1 (0x01)	32
Table 23	Identifier 1, Address 2 (0x02)	32
Table 24	Identifier 2, Address 3 (0x03)	32
Table 25	Device Auto-Negotiation Advertisement, Address 4 (0x04)	33
Table 26	Auto-Negotiation Link Partner Ability, Address 5 (0x05)	33
Table 27	Auto-Negotiation Expansion, Address 6 (0x06)	34
Table 28	Auto-Negotiation Next Page Transmit, Address 7 (0x07)	34
Table 29	Auto-Negotiation LP Next Page Receive, Address 8 (0x08)	34
Table 30	100BASE-T Control, Address 9 (0x09)	35
Table 31	100BASE-T Status, Address 10 (0x0A)	35
Table 32	MMD EEE Access, Address 13 (0x0D)	36
Table 33	MMD Address or Data Register, Address 14 (0x0E)	36
Table 34	100BASE-T Status Extension 1, Address 15 (0x0F)	36
Table 35	100BASE-TX Status Extension, Address 16 (0x10)	36
Table 36	100BASE-T Status Extension 2, Address 17 (0x11)	37
Table 37	Bypass Control, Address 18 (0x12)	38
Table 38	Extended Control and Status, Address 19 (0x13)	38
Table 39	Extended Control and Status, Address 20 (0x14)	39
Table 40	Extended Control and Status, Address 21 (0x15)	39
Table 41	Extended Control and Status, Address 22 (0x16)	39
Table 42	Extended PHY Control 1, Address 23 (0x17)	40
Table 43	Extended PHY Control 2, Address 24 (0x18)	41
Table 44	Interrupt Mask, Address 25 (0x19)	41
Table 45	Interrupt Status, Address 26 (0x1A)	42
Table 46	Auxiliary Control and Status, Address 28 (0x1C)	43
Table 47	LED Mode Select, Address 29 (0x1D)	44
Table 48	LED Behavior, Address 30 (0x1E)	44
Table 49	Extended/GPIO Register Page Access, Address 31 (0x1F)	45
Table 50	Extended Registers Page 1 Space	45
Table 51	Cu Media CRC Good Counter, Address 18E1 (0x12)	45
Table 52	Extended Mode Control, Address 19E1 (0x13)	46
Table 53	Extended PHY Control 3, Address 20E1 (0x14)	46
Table 54	Extended PHY Control 4, Address 23E1 (0x17)	47
Table 55	EPG Control Register 1, Address 29E1 (0x1D)	48

Table 56	EPG Control Register 2, Address 30E1 (0x1E)	48
Table 57	Extended Registers Page 2 Space	49
Table 58	Cu PMD Transmit Control, Address 16E2 (0x10)	50
Table 59	EEE Control, Address 17E2 (0x11)	51
Table 60	RGMII Control, Address 20E2 (0x14)	52
Table 61	Wake-on-LAN MAC Address, 21E2 (0x15)	54
Table 62	Wake-on-LAN MAC Address, 22E2 (0x16)	54
Table 63	Wake-on-LAN MAC Address, 23E2 (0x17)	54
Table 64	Secure-On Password, 24E2 (0x18)	54
Table 65	Secure-On Password, 25E2 (0x19)	55
Table 66	Secure-On Password, 26E2 (0x1A)	55
Table 67	WoL and MAC Interface Control, Address 27E2 (0x1B)	55
Table 68	Extended Interrupt Mask, Address 28E2 (0x1C)	56
Table 69	Extended Interrupt Status, Address 29E2 (0x1D)	56
Table 70	Ring Resiliency, Address 30E2 (0x1E)	57
Table 71	General Purpose Registers Space	57
Table 72	CLKOUT Control, Address 13G (0x0D)	58
Table 73	GPIO Control 2, Address 14G (0x0E)	58
Table 74	MAC Configuration and Fast Link Register, Address 19G (0x13)	59
Table 75	Recovered Clock Control, Address 23G (0x17)	59
Table 76	Enhanced LED Control, Address 25G (0x19)	60
Table 77	Clause 45 Registers Page Space	60
Table 78	PMA/PMD Status 1	60
Table 79	PCS Status 1, Address 3.1	61
Table 80	EEE Capability, Address 3.20	61
Table 81	EEE Wake Error Counter, Address 3.22	61
Table 82	EEE Advertisement, Address 7.60	62
Table 83	EEE Advertisement, Address 7.61	62
Table 84	802.3bf Registers	62
Table 85	VDDMAC, VDDIO, and VDDMDIO (2.5 V) DC Characteristics	63
Table 86	VDDMAC, VDDIO, and VDDMDIO (3.3 V) DC Characteristics	63
Table 87	VDDMAC and VDDMDIO DC Characteristics (1.5 V)	64
Table 88	VDDMAC and VDDMDIO DC Characteristics (1.8 V)	64
Table 89	VDDMDIO DC Characteristics	64
Table 90	XTAL1 DC Characteristics	65
Table 91	LED DC Characteristics	65
Table 92	Internal Pull-Up or Pull-Down Resistors (GMII/MII/RGMII/RMII Interface)	65
Table 93	Internal Pull-Up or Pull-Down Resistors (Other I/Os)	65
Table 94	Current Consumption	66
Table 95	Current Consumption (VDDMAC)	66
Table 96	Power Consumption	66
Table 97	Thermal Diode Parameters	67
Table 98	RefClk	67
Table 99	XTAL RefClk	68
Table 100	Recovered Clock AC Characteristics	68
Table 101	CLKOUT AC Characteristics	69
Table 102	RMII_CLKOUT AC Characteristics	69
Table 103	Basic Serial LEDs AC Characteristics	70
Table 104	RMII AC Characteristics	70
Table 105	GMII Transmit AC Characteristics	70
Table 106	GMII Receive AC Characteristics	71
Table 107	MII Transmit AC Characteristics	72
Table 108	MII Receive AC Characteristics	72
Table 109	Uncompensated RGMII AC Characteristics	73
Table 110	PHY Input (GTX_CLK Delay When Register 20E2.[2:0]=011'b)	74
Table 111	PHY Output (RX_CLK Delay When Register 20E2.[6:4]=100'b)	75
Table 112	Start of Frame Indication AC Characteristics	75
Table 113	Serial Management Interface AC Characteristics	76
Table 114	Reset Timing AC Characteristics	77

Table 115	Recommended Operating Conditions .....	77
Table 116	Stress Ratings .....	78
Table 117	Pin Type Symbol Definitions .....	79
Table 118	Thermal Resistances .....	87
Table 119	Ordering Information .....	90

# 1 Revision History

---

The revision history describes the changes that were implemented in the document. The changes are listed by revision, starting with the most current publication.

## 1.1 Revision 4.2

Revision 4.2 of this datasheet was published in February 2019. In revision 4.2, VeriPHY descriptions were updated and VeriPHY register information was deleted. For functional details of the VeriPHY suite and operating instructions, see the ENT-AN0125 PHY, Integrated PHY-Switch VeriPHY - Cable Diagnostics application note.

## 1.2 Revision 4.1

Revision 4.1 of this document was published in October 2018. The following is a summary of the changes.

- Details of LED blink or pulse-stretch behavior were corrected. For more information, see [LED Blink or Pulse-Stretch](#), page 23.
- Information about fast link failure indication was updated. For more information, see [Fast Link Failure Indication](#), page 24 and [Fast Link Failure 2™ \(FLF2™\) Indication](#), page 24.
- Forced Mode link-up times were updated. For more information, see [Table 18](#), page 25.
- Clause 45 Registers list was updated. For more information, see [Table 77](#), page 60.
- 802.3bf register names were corrected. For more information, see [Table 84](#), page 62.
- Conditions were added for the input high voltage parameters of VDDMAC and VDDMDIO DC specifications (1.5 V and 1.8 V). For more information, see [Table 87](#), page 64 and [Table 88](#), page 64.
- Extended Mode Control register bits were designated as “sticky” where applicable. For more information, see [Table 52](#), page 46.
- Access for bit 1 of the Extended PHY Control 3 was corrected from read/write to read only. For more information, see [Table 53](#), page 46.
- [Table 60](#), page 52 Bit 12 of the RGMII Control register was designated as “sticky.” For more information, see [Table 60](#), page 52.
- Bits 4 and 0 of the WoL and MAC Interface Control register were designated as “sticky.” For more information, see [Table 67](#), page 55.
- REF\_CLK was clarified as RMII\_CLKIN in the RMII AC characteristics parameters. For more information, see [Table 104](#), page 70.
- The SMI reference description was corrected. For more information, see [Pins by Function](#), page 80.
- Additional design considerations were added. For more information, see [Design Considerations](#), page 88.

## 1.3 Revision 4.0

Revision 4.0 of this document was published in March 2017. This was the first publication.

## 2 Overview

The VSC8541-01 device is designed for space-constrained 10/100/1000BASE-T applications. It features integrated, line-side termination to conserve board space, lower EMI, and improve system performance. Additionally, integrated RGMII timing compensation eliminates the need for on-board delay lines.

Microsemi's EcoEthernet™ v2.0 technology supports IEEE 802.3az Energy-Efficient Ethernet (EEE) and power-saving features to reduce power based on link state and cable reach. VSC8541-01 optimizes power consumption in all link operating speeds and features a Wake-on-LAN (WoL) power management mechanism for bringing the PHY out of a low-power state using designated magic packets.

Fast link failure (FLF) indication for high availability networks identifies the onset of a link failure in less than 1 ms typical to go beyond the IEEE 802.3 standard requirement of 750 ms ±10 ms (link master). Potential link failure events can be more flexibly monitored using an enhanced FLF2 state machine, which goes beyond FLF indication by enabling signaling of the link potentially going down within 10 μs.

The device includes recovered clock output for Synchronous Ethernet applications. Programmable clock squelch control is included to inhibit undesirable clocks from propagating and to help prevent timing loops. Ring Resiliency allows a PHY port to switch between master and slave timing references with no link drop in 1000BASE-T mode.

The following illustration shows a high-level, general view of a typical VSC8541-01 application.

**Figure 1 • Application Diagram**

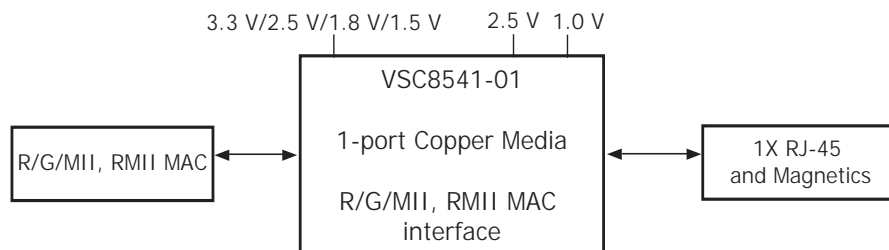

### 2.1 Key Features

This section lists the main features and benefits of the VSC8541-01 device.

#### 2.1.1 Superior PHY and Interface Technology

- Integrated 10/100/1000BASE-T Ethernet copper transceiver (IEEE 802.3ab compliant) with the industry's only non-TDR-based VeriPHY™ cable diagnostics algorithm
- Patented line driver with low EMI voltage mode architecture and integrated line-side termination resistors
- Wake-on-LAN using magic packets
- HP Auto-MDIX and manual MDI/MDIX support
- RGMII/GMII/MII/RMII MAC interface
- Jumbo frame support up to 16 kilobytes with programmable synchronization FIFOs

#### 2.1.2 Synchronous Ethernet and IEEE 1588 Time Stamp Support

- Recovered clock output with programmable clock squelch control for G.8261 Synchronous Ethernet applications
- 1000BASE-T Ring Resiliency feature to switch between master and slave timing without dropping link
- Clock output squelch to inhibit clocks during auto-negotiation and no link status
- Clause 45 registers to support IEEE 802.3bf
- IEEE 1588 Start of Frame (SOF) detection to enhance 1588v2 PTP time stamp accuracy (VSC8541XMV-04 only)

### 2.1.3 Fast Link Up/Link Drop Modes

- Fast link failure indication (<1 ms typical, programmable down to <10  $\mu$ S)
- Supports 1000Base-T forced mode for both master and slave end point configurations with constant link self-monitoring and link auto-reset should the link come down

### 2.1.4 Best-in-Class Power Consumption

- EcoEthernet™ v2.0 green energy efficiency with ActiPHY™, PerfectReach™, and IEEE 802.3az Energy-Efficient Ethernet
- Fully optimized power consumption for all link speeds
- Clause 45 registers to support Energy-Efficient Ethernet

### 2.1.5 Key Specifications

- Compliant with IEEE 802.3 (10BASE-T, 100BASE-TX, and 1000BASE-T) specifications
- Supports R/G/MII
- Supports 1.5 V, 1.8 V, 2.5 V, and 3.3 V CMOS for RGMII versions 1.3 and 2.0 (without HSTL support), GMII/MII as well as RMII version 1.2
- Supports a variety of clock sources: 25 MHz Xtal, 25 MHz OSC, 50 MHz OSC, 125 MHz OSC
- Supports programmable output frequencies of 25 MHz, 50 MHz, or 125 MHz, regardless of chosen Xtal or OSC frequencies
- Supports a wide array of stand-alone hardware configuration options
- Supports all 5 bits of MDIO/MDC addressing possible for managed mode designs using pull-up/pull-down resistors
- Low alpha mold compound enables 80 SER FIT (VSC8541XMV-04 only)
- Devices support operating temperatures of  $-40$  °C ambient to  $125$  °C junction or  $0$  °C ambient to  $125$  °C junction
- Optionally reports if a link partner is requesting inline Power-over-Ethernet (PoE and PoE+)
- Available in 8 mm x 8 mm, 68-pin QFN package

## 2.2 Block Diagram

The following illustration shows the primary functional blocks of the VSC8541-01 device.

Figure 2 • Block Diagram

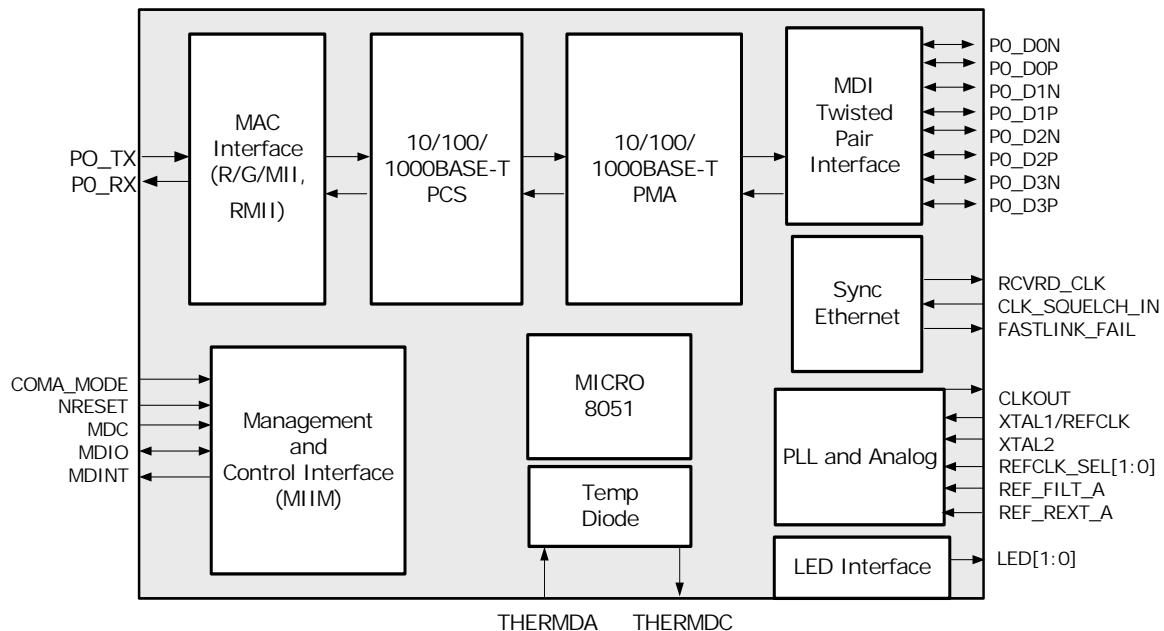

## 3 Functional Descriptions

This section describes the functional aspects of the VSC8541-01 device, including available configurations, operational features, and testing functionality. It also defines the device setup parameters that configure the device for a particular application.

### 3.1 Operating Modes

The following table lists the operating modes of the VSC8541-01 device.

**Table 1 • Operating Modes**

Operating Mode	Supported Media
RGMII-Cat5	10/100/1000BASE-T
GMII-Cat5	10/100/1000BASE-T
RMII-Cat5	10/100BASE-T

### 3.2 MAC Interface

The VSC8541-01 device supports RMII version 1.2, RGMII versions 1.3 and 2.0, and GMII/MII MAC interfaces at 1.5 V, 1.8 V, 2.5 V, and 3.3 V operating voltages. In order to help reduce EMI, the VSC8541-01 device also includes edge rate programmability for the MAC interface signals through register 27E2.7:5.

The recommended values for  $R_S$  (as shown in [Figure 3](#), page 5, [Figure 4](#), page 5, [Figure 6](#), page 7, and [Figure 7](#), page 7) are listed in the following table.

**Table 2 • Recommended Values for  $R_S$  ( $\pm 5\%$ )**

VDDMAC Value	$R_S$ Value
1.5 V	27 $\Omega$
1.8 V	33 $\Omega$
2.5 V	39 $\Omega$
3.3 V	39 $\Omega$

Refer to the MAC datasheet for the value to use for  $R_T$ .

#### 3.2.1 RGMII MAC Interface Mode

The VSC8541-01 device supports RGMII versions 1.3 and 2.0 (without HSTL modes). The RGMII interface supports all three speeds (10 Mbps, 100 Mbps, and 1000 Mbps) and is used as an interface to a RGMII-compatible MAC. The device is compliant with the RGMII interface specification when VDDMAC is operating at 2.5 V. While the RGMII specification only specifies operation at 2.5 V, the device can also support the RGMII interface at 1.5 V, 1.8 V, and 3.3 V.

**Figure 3 • RGMII MAC Interface**

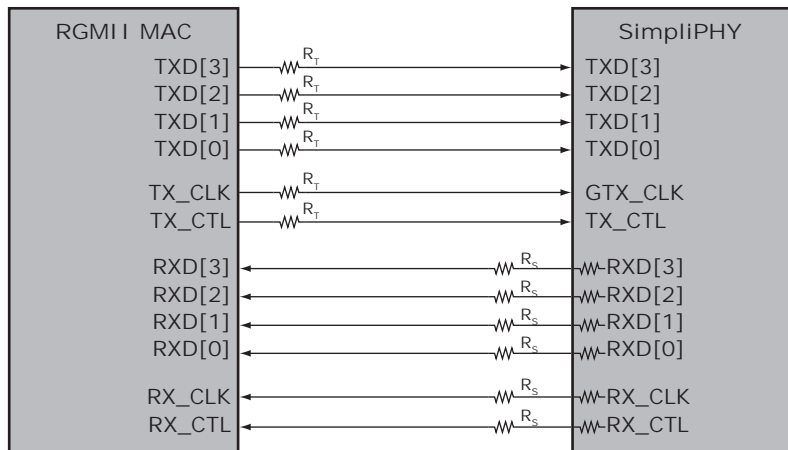

### 3.2.2 GMII/MII Interface Mode

The GMII/MII interface supports all three speeds (10 Mbps, 100 Mbps, and 1000 Mbps), and is used as an interface to a GMII/MII-compatible MAC. The device is compliant with the GMII/MII interface specification when VDDMAC is operating at 3.3 V. While the GMII/MII specification only specifies operation at 3.3 V, the device can also support the GMII/MII interface at 1.5 V, 1.8 V, and 2.5 V.

**Figure 4 • GMII/MII MAC Interface**

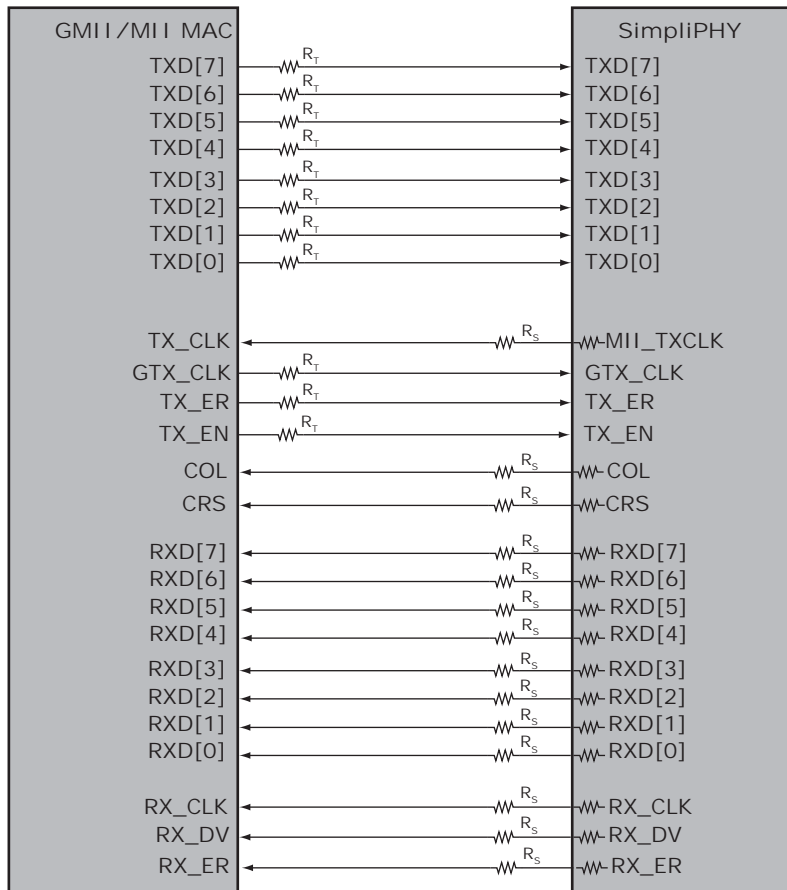

### 3.2.3 RMII Mode

The RMII interface supports 10 Mbps and 100 Mbps speeds, and is used as an interface to a RMII-compatible MAC. The device is compliant with the RMII interface specification when VDDMAC is operating at 3.3 V. While the RMII specification only specifies operation at 3.3 V, the device can also support the RMII interface at 1.5 V, 1.8 V, and 2.5 V.

**Figure 5 • RMII MAC Interface**

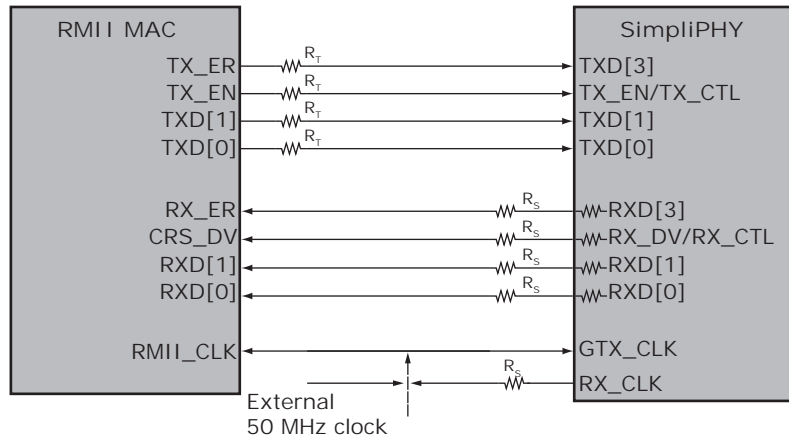

#### 3.2.3.1 RMII Pin Allocation

The following table lists the chip pins used for RMII signaling in RMII mode.

**Table 3 • RMII Pin Allocation**

Chip Pin	RMII Signal
GTX_CLK	RMII_CLKIN
RX_CLK	RMII_CLKOUT
TXD3	TX_ER (to support 802.3az)
TXD1	TXD1
TXD0	TXD0
TX_EN/TX_CTL	TX_EN
RXD1	RXD1
RXD0	RXD0
RXD3	RX_ER
RX_DV/RX_CTL	CRS_DV

Even though the RMII specification does not call for the use of TX\_ER signal, it is required in order to support Energy-Efficient Ethernet (802.3az).

#### 3.2.3.2 RMII Clocking Overview

When the device is in RMII mode, the clock inputs to the device need to support the various modes in which RMII devices can operate. There are two basic modes of operation in RMII mode:

- Mode 1—system provides a 50 MHz clock that is used to clock the RMII interface and must be used as the chip reference clock.
- Mode 2—PHY operates from a 25 MHz or 125 MHz reference clock, and sources the 50 MHz clock used for the RMII interface.

These two modes of operation and the clocking schemes are described in the following sections.

### 3.2.3.2.1 Mode 1

In this mode of operation, an external source is used to provide a 50 MHz clock through the RMII\_CLKIN and the XTAL1 pin. This 50 MHz clock is used as the main clock for the RMII interface, and must be used as the reference clock for the PHY connected to the XTAL1 pin. In this mode, the RMII\_CLKOUT signal from the PHY is not used. The RMII\_CLKOUT is enabled by default and that clock output should be disabled through register 27E2.4. The following figure illustrates RMII signal connections at the system level.

Figure 6 • Mode 1

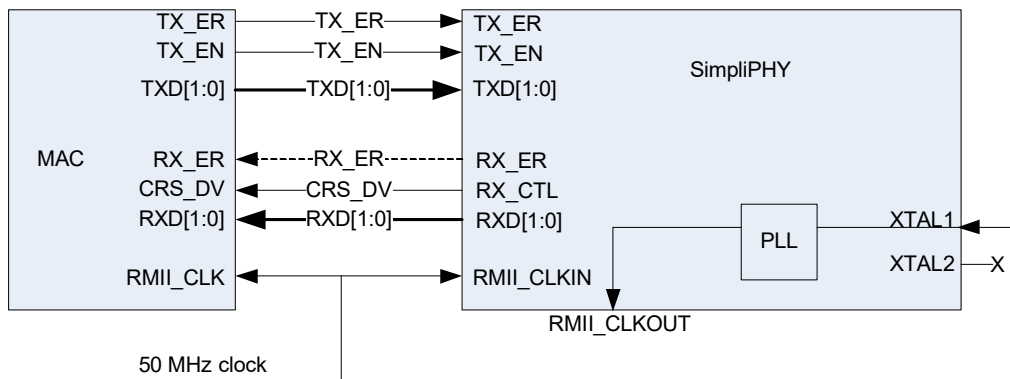

### 3.2.3.2.2 Mode 2

In this mode of operation, the PHY operates from a 25 MHz crystal (XTAL1 and XTAL2) or 25 MHz/125 MHz single-ended external clock (XTAL1), and sources the 50 MHz clock required for the RMII interface. This 50 MHz clock is output from the PHY on the RMII\_CLKOUT pin and then connected to the MAC and PHY RMII\_CLKIN signals. In this mode, the PHY generates a 50 MHz clock for the system and that clock output is enabled. The following figure illustrates RMII signal connections at the system level.

Figure 7 • Mode 2

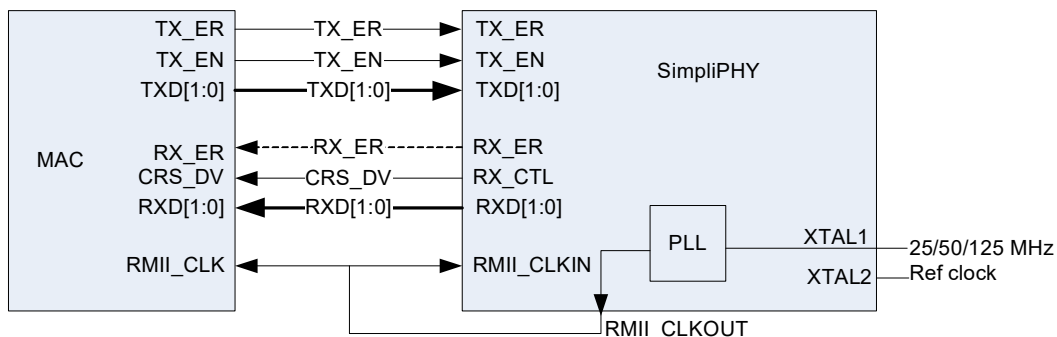

## 3.2.4 MAC Interface Edge Rate Control

The VSC8541-01 device includes programmable control of the rise/fall times for the MAC interface signals. The default setting will select the fastest rise/fall times. However, the fast edge rate will result in higher power consumption on the MAC interface and may result in higher EMI.

It is recommended that the user select the appropriate edge rate setting based on the VDDMAC supply voltage, as shown in the following table.

Table 4 • Recommended Edge Rate Settings

VDDMAC Voltage	Edge Rate Setting
3.3 V	100

**Table 4 • Recommended Edge Rate Settings (continued)**

VDDMAC Voltage	Edge Rate Setting
2.5 V	100
1.8 V	111
1.5 V	111

In order to further reduce power consumption and EMI, the user may elect to choose a slower edge rate than recommended if the end application supports it.

The MAC interface signal rise/fall times can be changed by writing to register bits 27E2.7:5. The typical change in edge rate for each setting at various VDDMAC voltages is shown in the following table.

**Table 5 • MAC Interface Edge Rate Control**

Register Setting	Edge Rate Change (VDDMAC)			
	3.3 V	2.5 V	1.8 V	1.5 V
111 (fastest)	Default	Default	Default (recommended)	Default (recommended)
110	-2%	-3%	-5%	-6%
101	-4%	-6%	-9%	-14%
100	-7% (recommended)	-10% (recommended)	-16%	-21%
011	-10%	-14%	-23%	-29%
010	-17%	-23%	-35%	-42%
001	-29%	-37%	-52%	-58%
000 (slowest)	-53%	-63%	-76%	-77%

These values are based on measurements performed on typical silicon at nominal supply and room temperature settings.

### 3.3 Hardware Mode Strapping and PHY Addressing

The VSC8541-01 device provides hardware-configured modes of operation that are achieved by sampling output pins on the rising edge of reset and externally pulling the pin to a logic HIGH or LOW (based on the desired configuration). These output pins are required by the device as inputs while NRESET is asserted and the logic state of the pin is latched in the device upon de-assertion of NRESET. To ensure correct operation of the hardware strapping function, any other device connected to these pins must not actively drive a signal onto them.

The following table describes the pins used for this purpose and their respective modes.

**Table 6 • Hardware Mode Strapping and PHY Addressing**

Pin(s)	Operation Mode
CLKOUT	Enable/disable CLKOUT signal
RX_CLK	Managed or unmanaged mode
RXD0	Signal A
RXD1	Signal B
RXD2	Signal C
RXD3	Signal D

**Table 6 • Hardware Mode Strapping and PHY Addressing (continued)**

Pin(s)	Operation Mode
RX_DV/RX_CTL	Signal E
MII_TXCLK	Select GMII/MII or RGMII/RMII MAC interface mode
RXD4	PHY address bit 0 in unmanaged mode
RXD5	PHY address bit 1 in unmanaged mode
RXD6	CLKOUT frequency selection bit 0
RXD7	CLKOUT frequency selection bit 1
RX_ER	Enable Forced 1000BT mode
COL	Force MASTER/SLAVE when Forced 1000BT mode is selected
CRS	Force MDI/MDIX when Forced 1000BT mode is selected

### 3.3.1 CLKOUT Signal Configuration

When the CLKOUT signal is pulled LOW and the state of that signal is latched to logic 0 on the rising edge of reset, the CLKOUT output is disabled and the device will drive a logic low level on that pin after reset de-assertion. When the CLKOUT signal is pulled HIGH externally and the state of that signal is latched to logic 1, the CLKOUT output is enabled. This behavior can also be controlled through register 13G.15.

The CLKOUT signal is frequency-locked to the reference clock signal input through XTAL1/XTAL2 pins. The frequency of CLKOUT can be programmed to the following values through register 13G.14:13:

- 25 MHz
- 50 MHz
- 125 MHz

### 3.3.2 Managed Mode

When RX\_CLK pin is pulled LOW and the state of that signal is latched to logic 0 on the rising edge of reset, the device operates in a managed mode. In managed mode, the remaining 5 signals (A–E) are used to set the PHY address, allowing up to 32 devices to reside on the shared MDIO bus. In this mode, the device can be configured using register access and no additional hardware configurability is provided. The following table lists the assigned PHY address values in managed mode.

**Table 7 • Managed Mode**

Signal	PHY Address Values
Signal A	PHY address bit 0
Signal B	PHY address bit 1
Signal C	PHY address bit 2
Signal D	PHY address bit 3
Signal E	PHY address bit 4

### 3.3.3 Unmanaged Mode

When RX\_CLK is pulled HIGH externally and the state of that signal is latched to logic 1 on the rising edge of reset, the device operates in an unmanaged mode. The signals A–E are used to set default chip configurations, as described in the following sections.

**Note:** Operating the device in unmanaged mode requires that the NRESET pin is asserted twice during device configuration (for more information, see [Configuration](#), page 27).

**Note:** The default values for the following registers depend on the chosen hardware strapping options.

- 0.13, 0.6—Forced speed selection
- 0.12—Enable autonegotiation
- 0.8—Duplex
- 0.9:8—1000BASE-T capability
- 23.12:11—MAC interface selection
- 19E1.3:2—Force MDI crossover
- 20E2.6:4—RX\_CLK delay
- 20E2.2:0—TX\_CLK delay

Additionally, the following registers are set to 1 by default in unmanaged mode.

- 28.6—ActiPHY enable
- 20E1.4—Link speed autoshift enable

### 3.3.3.1 Signals A and B

Signals A and B are used to set the RGMII RX\_CLK and TX\_CLK (GTX\_CLK) delay settings (as defined in register 20E2), as per the following table.

**Table 8 • Signals A and B**

Signals A, B	RX_CLK and TX_CLK Delay Setting
0, 0	000 - 0.2 ns
0, 1	010 - 1.1 ns
1, 0	100 - 2.0 ns
1, 1	110 - 2.6 ns

### 3.3.3.2 Signals C and D

Signals C and D are used to select the link advertisement settings, as defined in the following table.

**Table 9 • Signals C and D**

Signals C, D	Link Advertisement
0, 0	Default mode of operation, 10/100/1000 FDX/HDX, autoneg ON
0, 1	10/100 FDX/HDX, autoneg ON (disable 1000BT advertisements)
1, 0	100BTX, HDX forced mode, autoneg OFF
1, 1	10BT, HDX forced mode, autoneg OFF

### 3.3.3.3 Signal E

Signal E is used to select between RMII and RGMII MAC interface modes. When the state of Signal E is latched to logic 0 on the rising edge of reset, the device operates in RGMII mode. When the state of Signal E is latched to logic 1 on the rising edge of reset, the device operates in RMII mode.

**Note:** RMII only supports 10/100 Mbps speeds. When RMII mode is selected, the link advertisement selection must also be changed to either 01, 10, or 11 settings, as defined in [Table 9](#), page 10.

**Note:** Correct configuration of the device is an end user responsibility, and no attempt is made in the device to disallow incorrect configurations.

Additionally, in unmanaged mode, the following settings are changed from their default values:

- Enable link speed downshift (register 20E1.4 set to 1)
- Enable ActiPHY (register 28.6 set to 1)

### 3.3.3.4 PHY Address Bit 0/1 Selection in Unmanaged Mode

The RXD4 and RXD5 pins can be pulled LOW or HIGH externally to set the bit 0 and bit 1 of the device PHY address. The upper 3 bits of the PHY address are always set to 0, and the lower 2 bits can be set to

one of 4 possible combinations through this external strapping option to provide a total of 4 PHY addresses in unmanaged operation.

### 3.3.4 GMII/MII or RGMII/RMII MAC Interface Mode

When MII\_TXCLK pin is pulled LOW externally and the state of that signal is latched to logic 0 on the rising edge of reset, the device operates in a RGMII mode. When MII\_TXCLK pin is pulled HIGH externally and the state of that signal is latched to logic 1 on the rising edge of reset, the device operates in GMII/MII mode (depending on link speed). This signal is bonded out to a package pin.

**Note:** If unmanaged mode is selected and Signal E is latched as a logic 1 (indicating RMII mode), the device will default to RMII mode regardless of the latched state of the MII\_TXCLK.

### 3.3.5 CLKOUT Frequency Selection

The RXD6 and RXD7 pins can be pulled LOW or HIGH externally to set the bit 0 and bit 1 default values of the CLKOUT frequency selection register 13G.14:13. The following table describes the allowed default CLKOUT frequency settings.

**Table 10 • CLKOUT Frequency Selection**

CLKOUT Frequency Selection	CLKOUT Frequency
00	25 MHz
01	50 MHz
10	125 MHz
11	Reserved

The CLKOUT frequency can be changed from the default setting to any of the other settings on any device variant by modifying the register bits through the SMI interface.

### 3.3.6 Forced 1000BASE-T Mode

When RX\_ER pin is pulled high externally and the state of that signal is latched to logic 1 on the rising edge of reset, the device operates in a Forced 1000BT mode. When this mode is enabled, the state of pins COL and CRS are latched on the rising edge of reset to configure Master/Slave and MDI/MDI-X, respectively. The latched state of the COL pin configures the device in Master mode when it is logic 1, and in Slave mode when it is logic 0. The latched state of the CRS pin configures the device in MDI mode when it is logic 0 and in MDI-X mode when it is logic 1.

## 3.4 Cat5 Twisted Pair Media Interface

The twisted pair interface is compliant with IEEE 802.3-2008 and the IEEE 802.3az-2010 standard for Energy-Efficient Ethernet.

### 3.4.1 Voltage Mode Line Driver

The VSC8541-01 device uses a patented voltage mode line driver that allows it to fully integrate the series termination resistors that are required to connect the PHY's Cat5 interface to an external 1:1 transformer. The interface does not require the user to place an external voltage on the center tap of the magnetic. The following figure illustrates the connections.

Figure 8 • Cat5 Media Interface

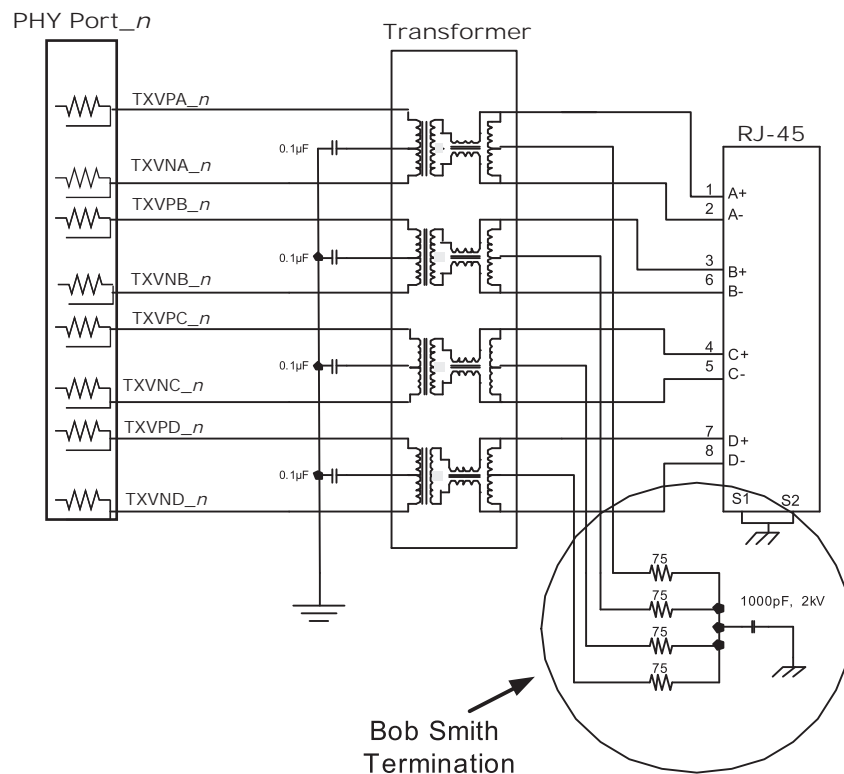

### 3.4.2 Cat5 Auto-Negotiation and Parallel Detection

The VSC8541-01 device supports twisted pair auto-negotiation, as defined by IEEE 802.3-2008 Clause 28 and IEEE 802.3az-2010. The auto-negotiation process evaluates the advertised capabilities of the local PHY and its link partner to determine the best possible operating mode. In particular, auto-negotiation can determine speed, duplex configuration, and master or slave operating modes for 1000BASE-TX. Auto-negotiation also enables a connected MAC to communicate with its link partner MAC through the VSC8541-01 device using optional next pages to set attributes that may not otherwise be defined by the IEEE standard.

If the Category 5 (Cat5) link partner does not support auto-negotiation, the VSC8541-01 device automatically uses parallel detection to select the appropriate link speed.

Auto-negotiation is disabled by clearing register 0, bit 12. When auto-negotiation is disabled, the state of register bits 0.6, 0.13, and 0.8 determine the device operating speed and duplex mode.

**Note:** While 10BASE-T and 100BASE-TX do not require auto-negotiation, IEEE 802.3-2008 Clause 40 has defined 1000BASE-T to require auto-negotiation.

### 3.4.3 Automatic Crossover and Polarity Detection

For trouble-free configuration and management of Ethernet links, the VSC8541-01 device includes a robust automatic crossover detection feature for all three speeds on the twisted pair interface (10BASE-T, 100BASE-T, and 1000BASE-T). Known as HP Auto-MDIX, the function is fully compliant with Clause 40 of IEEE 802.3-2008.

Additionally, the device detects and corrects polarity errors on all MDI pairs—a useful capability that exceeds the requirements of the standard.

Both HP Auto-MDIX detection and polarity correction are enabled in the device by default. Default settings can be changed using device register bits 18.5:4. Status bits for each of these functions are located in register 28.

**Note:** The VSC8541-01 device can be configured to perform HP Auto-MDIX, even when auto-negotiation is disabled and the link is forced into 10/100 speeds. To enable this feature, set register 18.7 to 0. To use the feature, also set register 0.12 to 0.

The HP Auto-MDIX algorithm successfully detects, corrects, and operates with any of the MDI wiring pair combinations listed in the following table, which shows that twisted pair A (of four twisted pairs A, B, C, and D) is connected to the RJ45 connector 1, 2 in normal MDI mode.

**Table 11 • Supported MDI Pair Combinations**

RJ45 Connections				
1, 2	3, 6	4, 5	7, 8	Mode
A	B	C	D	Normal MDI
B	A	D	C	Normal MDI-X
A	B	D	C	Normal MDI with pair swap on C and D pair
B	A	C	D	Normal MDI-X with pair swap on C and D pair

### 3.4.4 Manual MDI/MDIX Setting

As an alternative to HP Auto-MDIX detection, the PHY can be forced to be MDI or MDI-X using register 19E1, bits 3:2. Setting these bits to 10 forces MDI and setting 11 forces MDI-X. Leaving the bits 00 enables the HP Auto-MDIX setting to be based on register 18, bits 7 and 5.

### 3.4.5 Link Speed Downshift

For operation in cabling environments that are incompatible with 1000BASE-T, the VSC8541-01 device provides an automatic link speed downshift option. When enabled, the device automatically changes its 1000BASE-T auto-negotiation advertisement to the next slower speed after a set number of failed attempts at 1000BASE-T. No reset is required to get out of this state when a subsequent link partner with 1000BASE-T support is connected. This feature is useful in setting up in networks using older cable installations that include only pairs A and B, and not pairs C and D.

To configure and monitor link speed downshifting, set register 20E1, bits 4:1.

### 3.4.6 Energy-Efficient Ethernet

The VSC8541-01 device supports the IEEE 802.3az-2010 Energy-Efficient Ethernet standard to provide a method for reducing power consumption on an Ethernet link during times of low utilization. It uses low power idles (LPI) to achieve this objective.

**Figure 9 • Low Power Idle Operation**

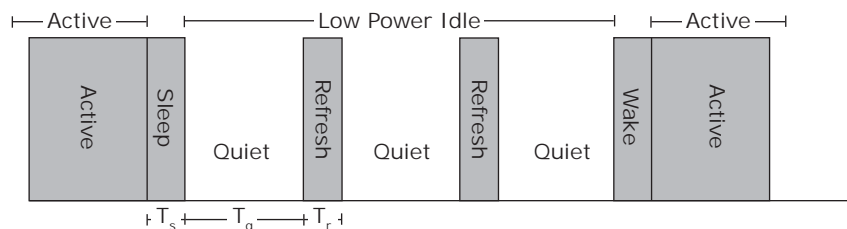

Using LPI, the usage model for the link is to transmit data as fast as possible and then return to a low power idle state. Energy is saved on the link by cycling between active and low power idle states. During LPI, power is reduced by turning off unused circuits and using this method, energy use scales with bandwidth utilization. The VSC8541-01 device uses LPI to optimize power dissipation in 100BASE-TX and 1000BASE-T modes of operation.

In addition, the IEEE 802.3az-2010 standard defines a 10BASE-Te mode that reduces transmit signal amplitude from 5 V peak-to-peak to approximately 3.3 V peak-to-peak. This mode reduces power consumption in 10 Mbps link speed and fully interoperates with legacy 10BASE-T-compliant PHYs over 100 m Cat5 cable or better.

To configure the VSC8541-01 device in 10BASE-Te mode, set register 17E2.15 to 1 for each port. Additional energy-efficient Ethernet features are controlled through Clause 45 registers. For more information, see [Clause 45 Registers to Support Energy-Efficient Ethernet and 802.3bf](#), page 60.

### 3.4.7 Ring Resiliency

Ring resiliency changes the timing reference between the master and slave PHYs without altering the master/slave configuration in 1000BASE-T mode. The master PHY transmitter sends data based on the local clock and initiates timing recovery in the receiver. The slave PHY instructs nodes to switch the local timing reference to the recovered clock from other PHYs in the box, freezes timing recovery, and locks clock frequency for the transmitter. The master PHY makes a smooth transition to transmission from local clock to recovered clock after timing lock is achieved.

Ring resiliency can be used in synchronous Ethernet systems because the local clocks in each node are synchronized to a grandmaster clock.

**Note:** For ring resiliency to successfully exchange master/slave timing over 1000BASE-T, the link partner must also support ring resiliency.

## 3.5 Reference Clock

The VSC8541-01 device supports multiple reference clock input options to allow maximum system level flexibility. There are two REFCLK\_SEL signals available to allow an end user to select between the various options. The following table shows the functionality and associated reference clock frequency.

**Table 12 • REFCLK Frequency Selection**

REFCLK_SEL [1:0]	Reference Clock Mode
00	25 MHz, on-chip oscillator ON (XTAL1/2 pins)
01	25 MHz, on-chip oscillator OFF (XTAL1 pin)
10	50 MHz, on-chip oscillator OFF (XTAL1 pin)
11	125 MHz, on-chip oscillator OFF (XTAL1 pin)

The following figure shows a reference tank circuit for a fundamental mode crystal.

**Note:** For best performance, traces on PCB should be of similar length and Kelvin-connected to ground.

**Figure 10 • XTAL Reference Clock**

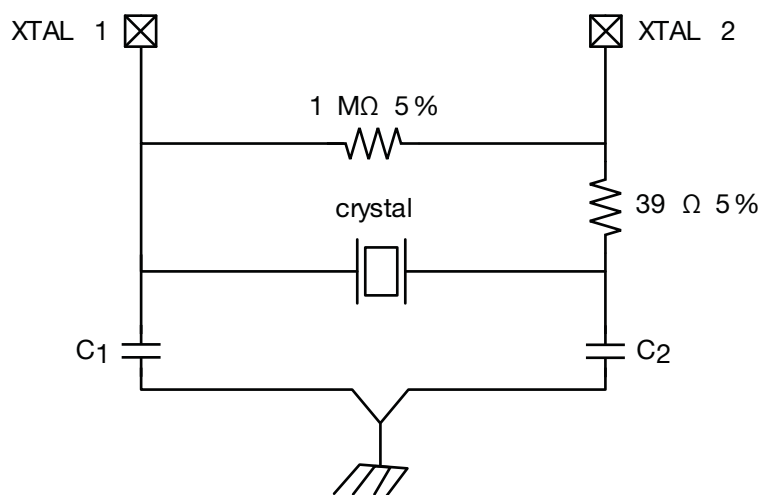

with REFCLK\_SEL [1:0] = 00

**Note:** Routing capacitance less than 1 pF from each XTAL pin to crystal device.

The following figure shows an external 3.3 V reference clock.

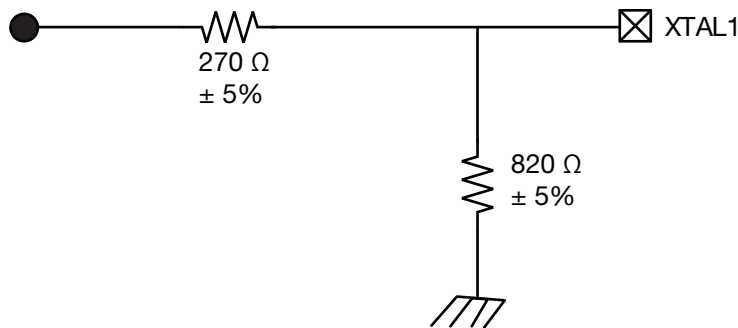
**Figure 11 • External 3.3 V Reference Clock**

**Note:** Reference clock source less than  $\lambda/10$  from XTAL1.

**Note:** No voltage scaling is required for a 2.5 V external reference.

## 3.6 Ethernet Inline-Powered Devices

The VSC8541-01 device can detect legacy inline-powered devices in Ethernet network applications. Inline-powered detection capability is useful in systems that enable IP phones and other devices (such as wireless access points) to receive power directly from their Ethernet cable, similar to office digital phones receiving power from a private branch exchange (PBX) office switch over telephone cabling. This type of setup eliminates the need for an external power supply and enables the inline-powered device to remain active during a power outage, assuming that the Ethernet switch is connected to an uninterrupted power supply, battery, back-up power generator, or other uninterruptable power source.

For more information about legacy inline-powered device detection, visit the Cisco website at [www.cisco.com](http://www.cisco.com). The following illustration shows an example of an inline-powered Ethernet switch application.

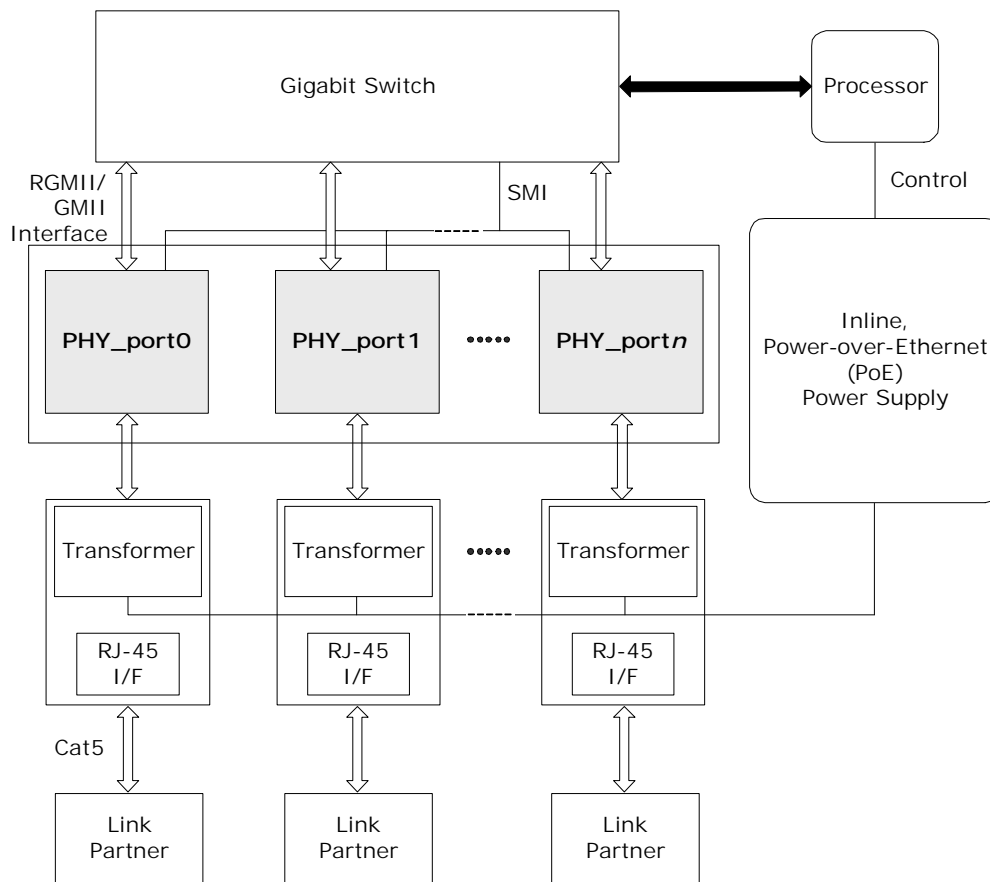
**Figure 12 • Inline-Powered Ethernet Switch Diagram**

The following procedure describes the steps that an Ethernet switch must perform to process inline-power requests made by a link partner that is, in turn, capable of receiving inline-power:

1. Enable the inline-powered device detection mode on each VSC8541-01 PHY using its serial management interface. Set register bit 23E1.10 to 1.
2. Ensure that the auto-negotiation enable bit (register 0.12) is also set to 1. In the application, the device sends a special fast link pulse signal to the link partner. Reading register bit 23E1.9:8 returns 00 during the search for devices that require Power-over-Ethernet (PoE).
3. The VSC8541-01 PHY monitors its inputs for the fast link pulse signal looped back by the link partner. A link partner capable of receiving PoE loops back the fast link pulses when the link partner is in a powered down state. This is reported when register bit 23E1.9:8 reads back 01. It can also be verified as an inline-power detection interrupt by reading register bit 26.9, which should be a 1, and which is subsequently cleared and the interrupt de-asserted after the read. When a link partner device does not loop back the fast link pulse after a specific time, register bit 23E1.9:8 automatically resets to 10.
4. If the VSC8541-01 PHY reports that the link partner requires PoE, the Ethernet switch must enable inline-power on this port, independent of the PHY.
5. The PHY automatically disables inline-powered device detection when the register bits 23E1.9:8 automatically reset to 10, and then automatically changes to its normal auto-negotiation process. A link is then autonegotiated and established when the link status bit is set (register bit 1.2 is set to 1).
6. In the event of a link failure (indicated when register bit 1.2 reads 0), it is recommended that the inline-power be disabled to the inline-powered device independent of the PHY. The VSC8541-01 PHY disables its normal auto-negotiation process and re-enables its inline-powered device detection mode.

### 3.7 IEEE 802.3af Power-over-Ethernet Support

The VSC8541-01 device is compatible with designs intended for use in systems that supply power to data terminal equipment (DTE) by means of the MDI or twisted pair cable, as described in IEEE 802.3af Clause 33.

### 3.8 ActiPHY Power Management

In addition to the IEEE-specified power down control bit (device register bit 0.11), the VSC8541-01 device also includes an ActiPHY power management mode for each PHY. This mode enables support for power-sensitive applications. It utilizes a signal-detect function that monitors the media interface for the presence of a link to determine when to automatically power down the PHY. The PHY wakes up at a programmable interval and attempts to wake up the link partner PHY by sending a burst of fast link pulse over copper media.

The ActiPHY power management mode is enabled on a per-port basis during normal operation at any time by setting register bit 28.6 to 1.

The following operating states are possible when ActiPHY mode is enabled:

- Low power state
- Link partner wake-up state
- Normal operating state (link-up state)

The VSC8541-01 device switches between the low power state and link partner wake-up state at a programmable rate (the default is two seconds) until signal energy has been detected on the media interface pins. When signal energy is detected, the PHY enters the normal operating state. If the PHY is in its normal operating state and the link fails, the PHY returns to the low power state after the expiration of the link status time-out timer. After reset, the PHY enters the low power state.

When auto-negotiation is enabled in the PHY, the ActiPHY state machine operates as described.

When auto-negotiation is disabled and the link is forced to use 10BASE-T or 100BASE-TX modes while the PHY is in its low power state, the PHY continues to transition between the low power and link partner wake-up states until signal energy is detected on the media pins. At that time, the PHY transitions to the normal operating state and stays in that state even when the link is dropped. When auto-negotiation is disabled while the PHY is in the normal operation state, the PHY stays in that state when the link is dropped and does not transition back to the low power state.

The following illustration shows the relationship between ActiPHY states and timers.

**Figure 13 • ActiPHY State Diagram**

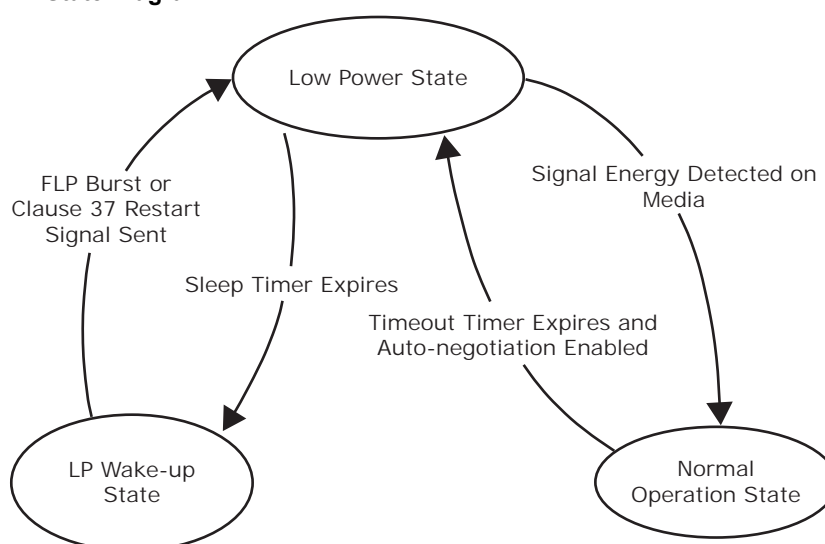

### 3.8.1 Low Power State

In the low power state, all major digital blocks are powered down. However, the SMI interface (MDC, MDIO, and MDINT) functionality is provided.

In this state, the PHY monitors the media interface pins for signal energy. The PHY comes out of low power state and transitions to the normal operating state when signal energy is detected on the media. This happens when the PHY is connected to an auto-negotiation-capable link partner or another PHY in enhanced ActiPHY link partner wake-up state

In the absence of signal energy on the media pins, the PHY periodically transitions from low-power state to link partner wake-up state, based on the programmable sleep timer (register bits 20E1.14:13). The actual sleep time duration is randomized from –80 ms to 60 ms to avoid two linked PHYs in ActiPHY mode entering a lock-up state during operation.

### 3.8.2 Link Partner Wake-Up State

In the link partner wake-up state, the PHY attempts to wake up the link partner. Up to three complete fast link pulse bursts are sent on alternating pairs A and B of the Cat5 media for a duration based on the wake-up timer, which is set using register bits 20E1.12:11.

In this state, SMI interface (MDC, MDIO, and MDINT) functionality is provided.

After sending signal energy on the relevant media, the PHY returns to the low power state.

### 3.8.3 Normal Operating State

In the normal operating state, the PHY establishes a link with a link partner. When the media is unplugged or the link partner is powered down, the PHY waits for the duration of the programmable link status time-out timer, which is set using register bit 28.7 and bit 28.2. It then enters the low power state.

## 3.9 Media Recovered Clock Output

For Synchronous Ethernet applications, VSC8541-01 includes a recovered clock output pin, RCVRD\_CLK, controlled by register 23G. The recovered clock pin is synchronized to the clock of the active media link.

To enable recovered clock output, set register 23G bit 15 and bit 0 to 1. By default, the recovered clock output pin is disabled and held low, including when NRESET is asserted. Register 23G also controls the clock source, the clock frequency (either 25 MHz, 31.25 MHz, or 125 MHz), and squelch conditions.

**Note:** When EEE is enabled on a link, the use of the recovered clock output is not recommended due to long holdovers occurring during EEE quiet/refresh cycles.

### 3.9.1 Clock Output Squelch

Under certain conditions, such as when there is no link present or during auto-negotiation, the PHY outputs a clock based on the REFCLK pin. To prevent an undesirable clock from appearing on the recovered clock pins, the VSC8541-01 device squelches, or inhibits, the clock output based on any of the following criteria:

- No link is detected (the link status register 1, bit 2 = 0).
- The link is found to be unstable using the fast link failure detection feature. The FASTLINK-FAIL pin is asserted high when enabled.
- The active link is in 10BASE-T or in 1000BASE-T master mode. These modes produce unreliable recovered clock sources.
- CLK\_SQUELCH\_IN is enabled to squelch the clock.

Use register 23G bits 5:4 to configure the clock squelch criteria. This register can also disable the squelch feature. The CLK\_SQUELCH\_IN pin controls the squelching of the clock. The recovered clock output is squelched when the CLK\_SQUELCH\_IN pin is high. This pin should not be left floating.

## 3.10 Serial Management Interface

The VSC8541-01 device includes an IEEE 802.3-compliant Serial Management Interface (SMI) that is affected by use of its MDC and MDIO pins. The SMI provides access to device control and status

registers. The register set that controls the SMI consists of 32 16-bit registers, including all required IEEE-specified registers. Additional pages of registers are accessible using device register 31.

Energy-efficient Ethernet control registers are available through the SMI using Clause 45 registers and Clause 22 register access in registers 13 through 14.

The SMI is a synchronous serial interface with input data to the VSC8541-01 device on the MDIO pin that is clocked on the rising edge of the MDC pin. The output data is sent on the MDIO pin on the rising edge of the MDC signal. The interface can be clocked at a rate from 0 MHz to 12.5 MHz, depending on the total load on MDIO. An external 2 k $\Omega$  pull-up resistor is required on the MDIO pin.

### 3.10.1 SMI Frames

Data is transferred over the SMI using 32-bit frames with an optional, arbitrary-length preamble. Before the first frame can be sent, at least two clock pulses on MDC must be provided with the MDIO signal at logic one to initialize the SMI state machine. The following illustrations show the SMI frame format for read and write operations.

**Figure 14 • SMI Read Frame**

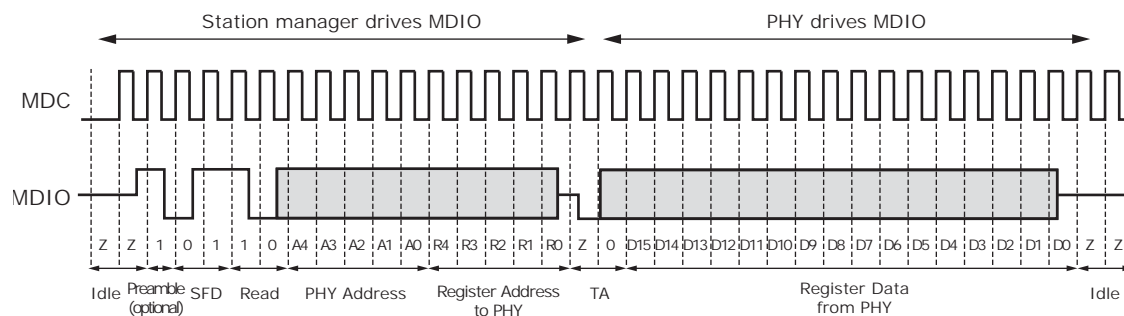

**Figure 15 • SMI Write Frame**

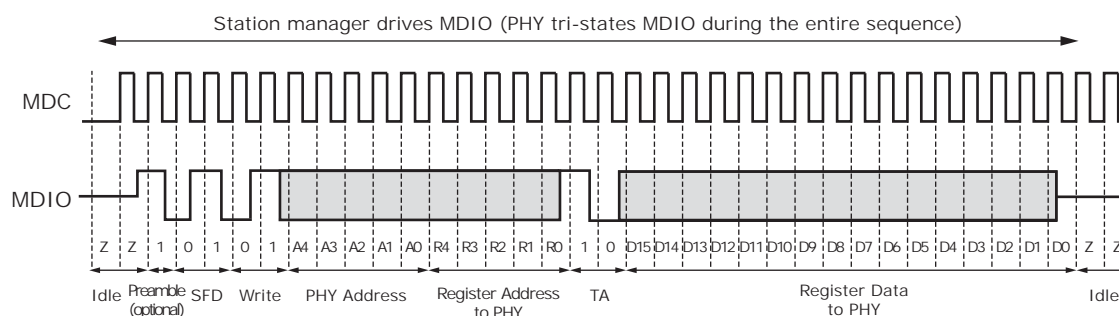

The following list defines the terms used in the SMI read and write timing diagrams.

- **Idle**—During idle, the MDIO node goes to a high-impedance state. This allows an external pull-up resistor to pull the MDIO node up to a logical 1 state. Because the idle mode does not contain any transitions on MDIO, the number of bits is undefined during idle.
- **Preamble**—By default, preambles are not expected or required. The preamble is a string of ones. If it exists, the preamble must be at least 1 bit; otherwise, it can be of an arbitrary length.
- **Start of Frame Delimiter (SFD)**—A pattern of 01 indicates the start of frame. If the pattern is not 01, all following bits are ignored until the next preamble pattern is detected.
- **Read or Write Opcode**—A pattern of 10 indicates a read. A 01 pattern indicates a write. If the bits are not either 01 or 10, all following bits are ignored until the next preamble pattern is detected.
- **PHY Address**—The particular VSC8541-01 device responds to a message frame only when the received PHY address matches its physical address. The physical address is 5 bits long (4:0).
- **Register Address**—The next five bits are the register address.
- **Turnaround**—The two bits used to avoid signal contention when a read operation is performed on the MDIO are called the turnaround (TA) bits. During read operations, the VSC8541-01 device drives the second TA bit, a logical 0.

- **Data**—The 16-bits read from or written to the device are considered the data or data stream. When data is read from a PHY, it is valid at the output from one rising edge of MDC to the next rising edge of MDC. When data is written to the PHY, it must be valid around the rising edge of MDC.
- **Idle**—The sequence is repeated.

### 3.10.2 SMI Interrupt

The SMI includes an interrupt signal, MDINT, for signaling the station manager when certain events occur in the VSC8541-01 device.

When a PHY generates an interrupt, the MDINT pin is asserted by driving low if the interrupt pin enable bit (register 25.15) is set. The MDINT pin is configured for open-drain (active-low) operation. Tie the pin to a pull-up resistor to VDDMDIO. The following illustration shows the configuration.

**Figure 16 • MDINT Configured as an Open-Drain (Active-Low) Pin**

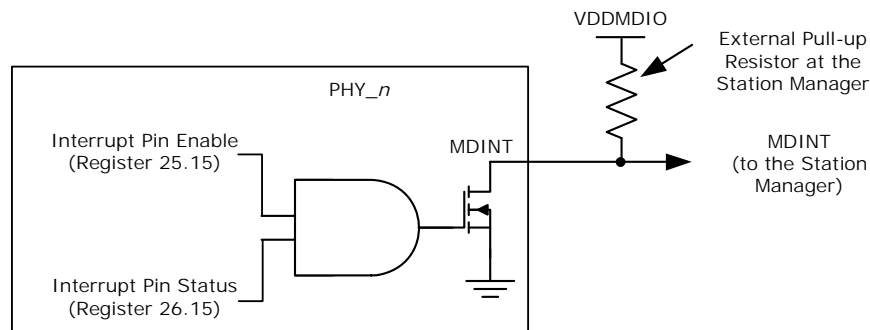

## 3.11 LED Interface

The LED interface supports direct drive and basic serial LED mode configuration. The polarity of the LED outputs is programmable and can be changed using register 17E2, bits 13:10. The default polarity is active low.

Direct drive mode provides two LED signals, LED0 and LED1. The mode and function of each LED signal can be configured independently.

In basic serial LED mode, all signals that can be displayed on LEDs are sent as LED\_Data and LED\_CLK for external processing.

The following table shows the bit 9 settings for register 14G that are used to control the LED behavior for all the LEDs in the VSC8541-01 device.

**Table 13 • LED Drive State**

Setting	Active	Not Active
14G.9 = 1 (default)	Ground	Tristate
14G.9 = 0 (alternate setting)	Ground	V <sub>DD</sub>

### 3.11.1 LED Modes

Each LED pin can be configured to display different status information that can be selected by setting the LED mode in register 29. The default LED state is active low and can be changed by modifying the value in register 17E2, bits 13:10. The blink/pulse stretch is dependent on the LED behavior setting in register 30.

The following table provides a summary of the LED modes and functions. The modes listed are equivalent to the setting used in register 29 to configure each LED pin.

**Table 14 • LED Mode and Function Summary**

Mode	Function Name	LED State and Description
0	Link/Activity	1: No link in any speed on any media interface. 0: Valid link at any speed on any media interface. Blink or pulse-stretch = Valid link at any speed on any media interface with activity present.
1	Link1000/Activity	1: No link in 1000BASE-T. 0: Valid 1000BASE-T. Blink or pulse-stretch = Valid 1000BASE-T link with activity present.
2	Link100/Activity	1: No link in 100BASE-TX. 0: Valid 100BASE-TX. Blink or pulse-stretch = Valid 100BASE-TX link with activity present.
3	Link10/Activity	1: No link in 10BASE-T. 0: Valid 10BASE-T link. Blink or pulse-stretch = Valid 10BASE-T link with activity present.
4	Link100/1000/Activity	1: No link in 100BASE-TX or 1000BASE-T. 0: Valid 100BASE-TX or 1000BASE-T link. Blink or pulse-stretch = Valid 100BASE-TX or 1000BASE-T link with activity present.
5	Link10/1000/Activity	1: No link in 10BASE-T or 1000BASE-T. 0: Valid 10BASE-T or 1000BASE-T link. Blink or pulse-stretch = Valid 10BASE-T or 1000BASE-T link with activity present.
6	Link10/100/Activity	1: No link in 10BASE-T or 100BASE-TX. 0: Valid 10BASE-T or 100BASE-TX link. Blink or pulse-stretch = Valid 10BASE-T or 100BASE-TX link with activity present.
7	Reserved	Reserved.
8	Duplex/Collision	1: Link established in half-duplex mode, or no link established. 0: Link established in full-duplex mode. Blink or pulse-stretch = Link established in half-duplex mode but collisions are present.
9	Collision	1: No collision detected. Blink or pulse-stretch = Collision detected.
10	Activity	1: No activity present. Blink or pulse-stretch = Activity present (becomes TX activity present when register bit 30.14 is set to 1).
11	Reserved	Reserved.
12	Autonegotiation Fault	1: No auto-negotiation fault present. 0: Auto-negotiation fault occurred.
13	Serial Mode	Serial stream. See <a href="#">Basic Serial LED Mode</a> , page 21. Only relevant on PHY port 0. Reserved in others.
14	Force LED Off	1: De-asserts the LED <sup>1</sup> .
15	Force LED On	0: Asserts the LED <sup>1</sup> .

1. Setting this mode suppresses LED blinking after reset.

### 3.11.2 Basic Serial LED Mode

The VSC8541-01 device can be configured so that access to all its LED signals is available through two pins. This option is enabled by setting LED0 to serial LED mode in register 29, bits 3:0 to 0xD. When

serial LED mode is enabled, the LED0 pin becomes the serial data pin, and the LED1 pin becomes the serial clock pin. The serial LED mode clocks the LED status bits on the rising edge of the serial clock.

The LED behavior settings can also be used in serial LED mode. The LED combine and LED blink or pulse-stretch setting of LED0 is used to control the behavior of each bit of the serial LED stream. To configure LED behavior, set device register 30.

The following table shows the serial output bitstream of each LED signal.

**Table 15 • LED Serial Bitstream Order**

Output	
Link/activity	1
Link1000/activity	2
Link100/activity	3
Link10/activity	4
Reserved	5
Duplex/collision	6
Collision	7
Activity	8
Reserved	9
Tx activity	10
Rx activity	11
Autonegotiation fault	12

### 3.11.3 Extended LED Modes

In addition to the LED modes in register 29, there are also additional LED modes that are enabled on the LED pin whenever the corresponding register 19E1, bits 13 to 12 are set to 1. Each of these bits enable an extended mode shown in the following table. For example, LED0 = mode 22 means that register 19E1 bit 12 = 1 and register 29 bits 3 to 0 = 0110.

The following table provides a summary of the extended LED modes and functions.

**Table 16 • Extended LED Mode and Function Summary**

Mode	Function Name	LED State and Description
16-19	Reserved	Reserved.
20	Force LED Off	1: De-asserts the LED.
21	Force LED On	0: Asserts the LED. LED pulsing is disabled in this mode.
22	Fast Link Fail	Enable fast link fail on the LED pin.
23	WoL interrupt	Enable WoL interrupt indication on the LED pin.

### 3.11.4 LED Behavior

Several LED behaviors can be programmed into the VSC8541-01 device. Use the settings in register 30 and 19E1 to program LED behavior, as described in the following sections.

#### 3.11.4.1 LED Combine

Enables an LED to display the status for a combination of primary and secondary modes. This can be enabled or disabled for each LED pin. For example, a copper link running in 1000BASE-T mode and activity present can be displayed with one LED by configuring an LED pin to Link1000/Activity mode. The LED asserts when linked to a 1000BASE-T partner and also blinks or performs pulse-stretch when

activity is either transmitted by the PHY or received by the link partner. When disabled, the combine feature only provides the status of the selected primary function. In this example, only Link1000 asserts the LED, and the secondary mode, Activity, does not display when the combine feature is disabled.

### 3.11.4.2 LED Blink or Pulse-Stretch

This behavior is available for the LED mode 9 (collision) and LED mode 10 (activity) indications only, and can be uniquely configured for each LED pin. For more information, see [Table 14](#), page 21. Activity and collision events can occur randomly and intermittently throughout the link-up period. Blink is a 50% duty cycle oscillation of asserting and de-asserting an LED pin. Pulse-stretch ensures that an LED is asserted and de-asserted for a specific period of time when activity is either present or not present. These rates can also be configured using a register setting.

### 3.11.4.3 Rate of LED Blink or Pulse-Stretch

This behavior controls the LED blink rate or pulse-stretch length when blink/pulse-stretch is enabled on a LED pin. The blink rate, which alternates between a high and low voltage level at a 50% duty cycle, can be set to 2.5 Hz, 5 Hz, 10 Hz, or 20 Hz. For pulse-stretch, the rate can be set to 50 ms, 100 ms, 200 ms, or 400 ms.

### 3.11.4.4 LED Pulsing Enable

To provide additional power savings, the LEDs (when asserted) can be pulsed at 5 kHz programmable duty cycle. The pulsing enable is controlled through register 30, bit 12 and the duty cycle through register 25G, bits 15:8.

### 3.11.4.5 LED Blink After Reset

The LEDs will blink for one second after COMA\_MODE is deasserted (as described in [Configuration](#), page 27) or a software reset is applied. This feature can be enabled by setting register 19E1, bit 11 = 1.

### 3.11.4.6 Pulse Programmable Control

These bits add the ability to width and frequency of LED pulses. This feature facilitates power reduction options.

### 3.11.4.7 Fast Link Failure

For more information about this feature, see [Fast Link Failure Indication](#), page 24.

## 3.12 Wake-On-LAN and SecureOn

The VSC8541-01 device supports Wake-on-LAN, an Ethernet networking standard to awaken hosts by using a “magic packet” that is decoded to ascertain the source, and then assert an interrupt pin or a LED. The VSC8541-01 device also supports SecureOn to secure Wake-on-LAN against unauthorized access. The following illustration shows an overview of the Wake-on-LAN functionality.

**Figure 17 • Wake-on-LAN Functionality**

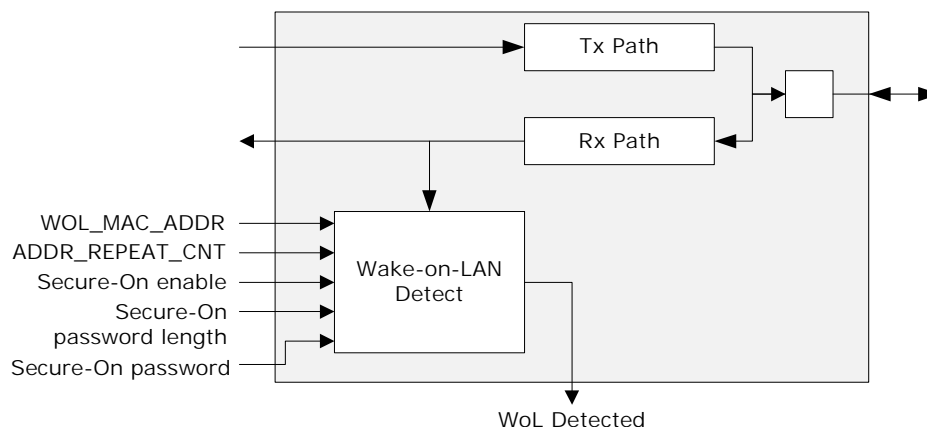

Wake-on-LAN detection is available in 10BASE-T, 100BASE-TX, and 1000BASE-T modes. It is enabled by setting the interrupt mask register (25.6) and its status is read in the interrupt status register (26.6). Wake-on-LAN and SecureOn are configured using register 27E2. The MAC address is saved in its local register space (21E2, 22E2, and 23E2).

### 3.13 Fast Link Failure Indication

To aid Synchronous Ethernet applications, the VSC8541-01 device can indicate the onset of a link failure in less than 1 ms in 1000BASE-T mode (<3 ms, worst case across all supported modes). In comparison, the IEEE 802.3 standard establishes a delay of up to 750 ms before indicating that a 1000BASE-T link is no longer present. A fast link failure indication is critical to support ports used in a synchronization timing link application. FLF indication works for all copper media speeds through the FASTLINK\_FAIL pin. Fast link failure is supported through the MDINT (active low) pin only in 1000BASE-T and 100BASE-TX modes. It is not supported through the MDINT pin and interrupt status register 26, bit 7 in 10BASE-T mode.

**Note:** For 10BASE-T links, the fast link failure indication matches the link status register (address 1, bit 2). For 100BASE-TX and 1000BASE-T links, the link failure is based on a circuit that analyzes the integrity of the link and will assert at the indication of failure.

**Note:** A system can later confirm the fast link down indication for system management purposes by actively polling the link status bit to determine if a link has failed.

**Note:** Fast Link Failure Indication and Fast Link Failure 2 Indication should not be used when EEE is enabled on a link.

### 3.14 Fast Link Failure 2™ (FLF2™) Indication

In order to enable specific industrial applications in which the system must be warned as quickly as possible that a link might be going down, the VSC8541-01 device features the FLF2 indicator function. This new feature enables the PHY to indicate the onset of a potential link failure in less than 10 μs for 1000BASE-T operation and 150 μs for 100BASE-TX operation. FLF2 is supported through the FASTLINK\_FAIL pin.

This new functionality goes beyond the normal FLF indicator function, which must be enabled concurrently with FLF2, and is enabled by writing a 1 to bit 15 of register 20E2.

A system can later confirm the fast link down indication for system management purposes by actively polling the link status bit to determine if a link has failed.

**Note:** For 10/100 links, the notification timing performance is only guaranteed for link loss due to failure of the PHY MDI pair operating as the ingress (receive) pair to the PHY.

**Note:** FLF2 should not be used when EEE is enabled on a link.

### 3.15 Start of Frame (SOF) Indication (VSC8541-04 Only)

The VSC8541-04 device includes support for IEEE 1588 timing by generating a SOF pulse when the Start of Frame Delimiter (SFD, octet 0xD5) is detected by the PCS engine. The pulse indicates the actual time the SFD symbol is received at the PCS. There is a fixed timing relationship from the time the SFD arrives at the PCS to when it appears on the line in the receive or transmit direction. Use of this signal decreases the additional variability in timing from the MAC interface to the PCS that can result from multiple clock domain crossings. For 1000BASE-T or 100BASE-TX, the SOF signal can have variability of ±4 ns.

The SOF pulse is generated in both transmit and receive directions and the associated clocks used in the PCS engines are also output to chip pins to provide an accurate timing reference. These signals are

multiplexed onto the higher order GMII signals and are only available when using the RGMII or RMII interface modes. To enable this functionality, set register bit 20E2.12 to 1.

**Table 17 • SOF Indication**

Pin	Signal
RXD7	RX_SOF
RXD6	RX_SOF_CLK
RXD5	TX_SOF
RXD4	TX_SOF_CLK

**Figure 18 • SOF Indication**

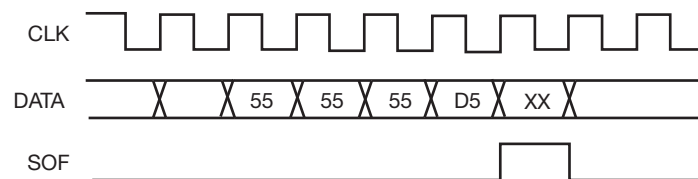

## 3.16 Forced Speed Mode Link-Up Timing

The following table specifies the time the device will take to establish a link when operating in a forced speed mode.

**Table 18 • Forced Speed Mode Link-Up Timing**

Forced Mode	Minimum	Maximum	Units
1000Base-T Master	292	1600	ms
1000Base-T Slave	220	1400	ms
100Base-TX, HP Auto-MDIX Disabled	43	240	ms
100Base-TX, HP Auto-MDIX Enabled	43	4000	ms

When using the 1000 Mbps forced speed mode (register 0 bit 6=1, bit 13=0), manually configure the PHY as master or slave by programming bits 12 and 11 in register 9 (1000BASE-T Control) and MDI or MDIX by programming bits 3:2 in register 19E1 (Extended Mode Control). HP Auto-MDIX is not supported in Forced 1000 Mode. In 100Base-TX mode, HP Auto-MDIX can be disabled by setting register 18 bit 7.

Link-up times are given for previously-configured PHYs on each side of the link— that is, the times do not include configuration time prior to attempting link-up. Both the device and link partner must be configured in forced speed mode to achieve the listed link-up times.

## 3.17 Testing Features

The VSC8541-01 device includes several testing features designed to facilitate performing system-level debugging and in-system production testing. This section describes the available features.

### 3.17.1 Ethernet Packet Generator

The Ethernet Packet Generator (EPG) can be used at each of the 10/100/1000BASE-T speed settings for copper Cat5 media to isolate problems between the MAC and the VSC8541-01 device, or between a locally connected PHY and its remote link partner. Enabling the EPG feature disables all MAC interface transmit pins and selects the EPG as the source for all data transmitted onto the twisted pair interface.

**Note:** The EPG is intended for use with laboratory or in-system testing equipment only. Do not use the EPG testing feature when the VSC8541-01 device is connected to a live network.

To enable the EPG feature, set the device register bit 29E1.15 to 1.

When the EPG is enabled, packet loss occurs during transmission of packets from the MAC to the PHY. However, the PHY receive output pins to the MAC are still active when the EPG is enabled. When it is necessary to disable the MAC receive pins as well, set the register bit 0.10 to 1.

When the device register bit 29E1.14 is set to 1, the PHY begins transmitting Ethernet packets based on the settings in registers 29E1 and 30E1. These registers set:

- Source and destination addresses for each packet
- Packet size
- Interpacket gap
- FCS state
- Transmit duration
- Payload pattern

When register bit 29E1.13 is set to 0, register bit 29E1.14 is cleared automatically after 30,000,000 packets are transmitted.

### 3.17.2 Far-End Loopback

The far-end loopback testing feature is enabled by setting register bit 23.3 to 1. When enabled, it forces incoming data from a link partner on the current media interface into the MAC interface of the PHY where it is retransmitted back to the link partner on the media interface, as shown in the following illustration. In addition, the incoming data also appears on the receive data pins of the MAC interface. Data present on the transmit data pins of the MAC interface is ignored when using this testing feature.

**Figure 19 • Far-End Loopback Diagram**

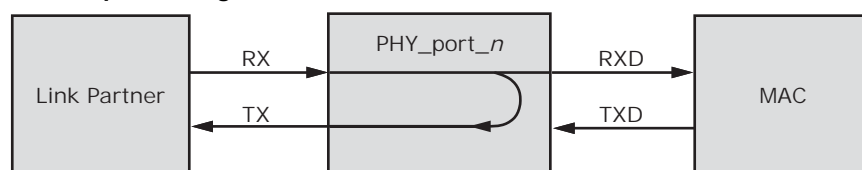

### 3.17.3 Near-End Loopback

When the near-end loopback testing feature is enabled, transmitted data (TXD) is looped back in the PCS block onto the receive data signals (RXD), as shown in the following illustration. When using this testing feature, no data is transmitted over the network. To enable near-end loopback, set the device register bit 0.14 to 1.

**Figure 20 • Near-End Loopback Diagram**

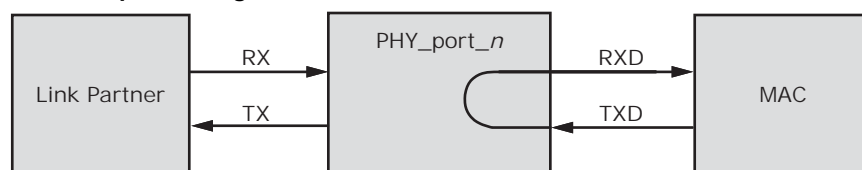

### 3.17.4 Connector Loopback

The connector loopback testing feature allows the twisted pair interface to be looped back externally. When using this feature, the PHY must be connected to a loopback connector or a loopback cable. Connect pair A to pair B, and pair C to pair D, as shown in the following illustration. The connector loopback feature functions at all available interface speeds.

**Figure 21 • Connector Loopback Diagram**

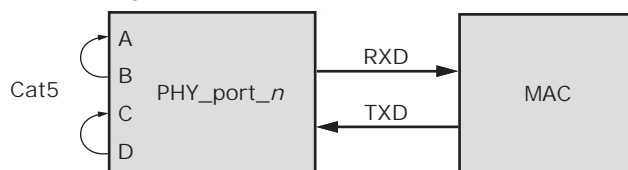

When using the connector loopback testing feature, the device auto-negotiation, speed, and duplex configuration is set using device registers 0,4, and 9.

For 1000BASE-T connector loopback, additional writes are required in the following order:

1. Enable the 1000BASE-T connector loopback. Set register bit 24.0 to 1.
2. Disable pair swap correction. Set register bit 18.5 to 1.

### 3.17.5 VeriPHY Cable Diagnostics

The VSC8541-01 includes a comprehensive suite of cable diagnostic functions that are available using SMI reads and writes. These functions enable a variety of cable operating conditions and status to be accessed and checked. The VeriPHY suite has the ability to identify the cable length and operating conditions and to isolate a variety of common faults that can occur on Cat5 twisted pair cabling.

For functional details of the VeriPHY suite and the operating instructions, see the ENT-AN0125 PHY, Integrated PHY-Switch VeriPHY - Cable Diagnostics application note.

## 3.18 Configuration

The VSC8541-01 device can be configured by setting internal memory registers using the management interface or by using the unmanaged mode as described in [Unmanaged Mode](#), page 9.

### 3.18.1 Managed Applications

To configure the device using the management interface, perform the following steps:

1. COMA\_MODE active, drive high (optional).
2. Apply power.
3. Apply RefClk.
4. Release reset, drive high. Power and clock must be high before releasing reset.
5. Wait 15 ms minimum.
6. Apply patch from PHY\_API if available (required for production release, optional for board testing).
7. Configure register 23 for MAC interface mode.
  - Read register 23 (to access register 23, register 31 must be 0).
  - Set bits 12:11, MAC configuration, as follows:
    - 00: GMII/MII
    - 10: RGMII
    - 01: RMII
  - Write new register 23.
8. Software reset.
  - Read register 0 (to access register 0, register 31 must be 0).
  - Set bit 15 to 1.
  - Write new register 0.
9. Read register 0 until bit 15 equals to 0.
10. For RGMII mode: configure register 20E2 (to access register 20E2, register 31 must be set to 2). Set bit 11 to 0 and set RX\_CLK delay and TX\_CLK delay accordingly through bit [6:4] and/or bit [2:0] respectively.
11. Release the COMA\_MODE pin, drive low (only necessary if COMA\_MODE pin is driven high or unconnected).

### 3.18.2 Unmanaged Applications

To configure the device using unmanaged mode, perform the following steps:

1. Apply power.
2. Apply RefClk.
3. Release reset, drive high. Power and clock must be high before releasing reset.

**Note:** For unmanaged mode operation, the NRESET pin must have two rising edges (logical 0-1-0-1 transition sequence) applied at this step.

4. Wait 15 ms minimum.
5. (Optional) For applications that gain register access to the device using the management interface, steps 6–10 can then be performed in order to modify default settings.

### 3.18.3 Initialization

The COMA\_MODE pin provides an optional feature that may be used to control when the PHYs become active. The typical usage is to keep the PHYs from becoming active before they have been fully initialized. For more information, see [Configuration](#), page 27. Alternatively, the COMA\_MODE pin may be connected low (ground) and the PHYs will be fully active once out of reset.

## 4 Registers

This section provides information about how to configure the VSC8541-01 device using its internal memory registers and the management interface. The registers marked reserved and factory test should not be read or written to, because doing so may produce undesired effects.

The default value documented for registers is based on the value at reset; in some cases, that value may change immediately after reset.

The access type for each register is shown using the following abbreviations:

- RO: Read Only
- ROCR: Read Only, Clear on Read
- RO/LH: Read Only, Latch High
- RO/LL: Read Only, Latch Low
- R/W: Read and Write
- RWSC: Read and Write, Self-Clearing

The VSC8541-01 device uses several different types of registers:

- IEEE Clause 22 device registers with addresses from 0 to 31
- Two pages of extended registers with addresses from 17E1–30E1 and 16E2–30E2
- General-purpose registers with addresses from 0G to 30G
- IEEE Clause 45 devices registers accessible through the Clause 22 registers 13 and 14 to support IEEE 802.3az-2010 Energy-Efficient Ethernet registers and IEEE 802.3bf-2011 registers

The following illustration shows the relationship between the device registers and their address spaces.

**Figure 22 • Register Space Diagram**

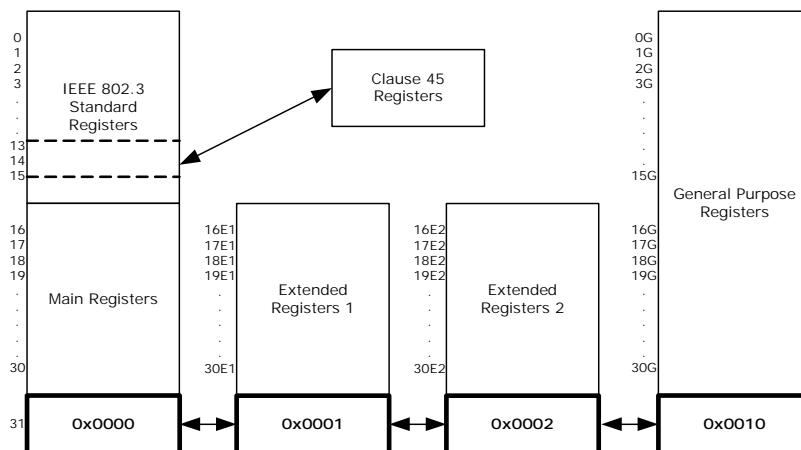

### Reserved Registers

For main registers 16–31, extended registers 17E1–30E1, 16E2–30E2, and general purpose registers 0G–30G, any bits marked as Reserved should be processed as read-only and their states as undefined.

### Reserved Bits

In writing to registers with reserved bits, use a read-modify-then-write technique, where the entire register is read but only the intended bits to be changed are modified. Reserved bits cannot be changed and their read state cannot be considered static or unchanging.

## 4.1 Register and Bit Conventions

This document refers to registers by their address and bit number in decimal notation. A range of bits is indicated with a colon. For example, a reference to address 26, bits 15 through 14 is shown as 26.15:14.

A register with an E and a number attached (such as 27E1) means it is a register contained within extended register page number 1. A register with a G attached (such as 13G) means it is a GPIO page register.

Bit numbering follows the IEEE standard with bit 15 being the most significant bit and bit 0 being the least significant bit.

## 4.2 IEEE 802.3 and Main Registers

In the VSC8541-01 device, the page space of the standard registers consists of the IEEE 802.3 standard registers and the Microsemi standard registers. The following table lists the names of the registers associated with the addresses as specified by IEEE 802.3.

**Table 19 • IEEE 802.3 Registers**

Address	Name
0	Mode Control
1	Mode Status
2	PHY Identifier 1
3	PHY Identifier 2
4	Auto-negotiation Advertisement
5	Auto-negotiation Link Partner Ability
6	Auto-negotiation Expansion
7	Auto-negotiation Next-Page Transmit
8	Auto-negotiation Link Partner Next-Page Receive
9	1000BASE-T Control
10	1000BASE-T Status
11–12	Reserved
13	MMD EEE Access
14	MMD Address or Data Register
15	1000BASE-T Status Extension 1

The following table lists the names of the registers in the main page space of the device. These registers are accessible only when register address 31 is set to 0x0000.

**Table 20 • Main Registers**

Address	Name
16	100BASE-TX status extension
17	1000BASE-T status extension 2
18	Bypass control
19	Error Counter 1
20	Error Counter 2
21	Error Counter 3
22	Extended control and status
23	Extended PHY control 1
24	Extended PHY control 2
25	Interrupt mask

**Table 20 • Main Registers (continued)**

Address	Name
26	Interrupt status
27	Reserved
28	Auxiliary control and status
29	LED mode select
30	LED behavior
31	Extended register page access

## 4.2.1 Mode Control

The device register at memory address 0 controls several aspects of the VSC8541-01 device functionality. The following table shows the available bit settings in this register and what they control.

**Table 21 • Mode Control, Address 0 (0x00)**

Bit	Name	Access	Description	Default
15	Software reset	R/W	Self-clearing. Restores all serial management interface (SMI) registers to default state, except for sticky and super-sticky bits. 1: Reset asserted. 0: Reset de-asserted. Wait 1 $\mu$ s after setting this bit to initiate another SMI register access.	0
14	Loopback	R/W	1: Loopback enabled. 0: Loopback disabled. When loopback is enabled, the device functions at the current speed setting and with the current duplex mode setting (bits 6, 8, and 13 of this register).	0
13	Forced speed selection LSB	R/W	Least significant bit. MSB is bit 6. 00: 10 Mbps 01: 100 Mbps 10: 1000 Mbps 11: Reserved	0
12	Autonegotiation enable	R/W	1: Autonegotiation enabled. 0: Autonegotiation disabled.	1
11	Power-down	R/W	1: Power down enabled.	0
10	Isolate	R/W	1: Disable MAC interface outputs and ignore MAC interface inputs.	0
9	Restart autonegotiation	R/W	Self-clearing bit. 1: Restart autonegotiation on media interface.	0
8	Duplex	R/W	1: Full-duplex. 0: Half-duplex.	0
7	Collision test enable	R/W	1: Collision test enabled.	0
6	Forced speed selection MSB	R/W	Most significant bit. LSB is bit 13. <sup>1</sup> 00: 10 Mbps 01: 100 Mbps 10: 1000 Mbps 11: Reserved	1
5:0	Reserved		Reserved.	00000

1. Before selecting the 1000 Mbps forced speed mode, manually configure the PHY as master or slave by setting bit 11 in register 9 (1000BASE-T Control) and MDI or MDIX by setting bits 3:2 in register 19E1 (Extended Mode Control).

## 4.2.2 Mode Status

The register at address 1 in the device main registers space enables reading the currently enabled mode setting. The following table shows possible readouts of this register.

**Table 22 • Mode Status, Address 1 (0x01)**

Bit	Name	Access	Description	Default
15	100BASE-T4 capability	RO	1: 100BASE-T4 capable.	0
14	100BASE-TX FDX capability	RO	1: 100BASE-TX FDX capable.	1
13	100BASE-TX HDX capability	RO	1: 100BASE-TX HDX capable.	1
12	10BASE-T FDX capability	RO	1: 10BASE-T FDX capable.	1
11	10BASE-T HDX capability	RO	1: 10BASE-T HDX capable.	1
10	100BASE-T2 FDX capability	RO	1: 100BASE-T2 FDX capable.	0
9	100BASE-T2 HDX capability	RO	1: 100BASE-T2 HDX capable.	0
8	Extended status enable	RO	1: Extended status information present in register 15.	1
7	Reserved	RO	Reserved.	
6	Preamble suppression capability	RO	1: MF preamble can be suppressed. 0: MF required.	1
5	Autonegotiation complete	RO	1: Auto-negotiation complete.	0
4	Remote fault	RO	Latches high. 1: Far-end fault detected.	0
3	Autonegotiation capability	RO	1: Auto-negotiation capable.	1
2	Link status	RO	Latches low. 1: Link is up.	0
1	Jabber detect	RO	Latches high. 1: Jabber condition detected.	0
0	Extended capability	RO	1: Extended register capable.	1

## 4.2.3 Device Identification

All 16 bits in both register 2 and register 3 in the VSC8541-01 device are used to provide information associated with aspects of the device identification. The following tables list the expected readouts.

**Table 23 • Identifier 1, Address 2 (0x02)**

Bit	Name	Access	Description	Default
15:0	Organizationally unique identifier (OUI)	RO	OUI most significant bits (3:18)	0x0007

**Table 24 • Identifier 2, Address 3 (0x03)**

Bit	Name	Access	Description	Default
15:10	OUI	RO	OUI least significant bits (19:24)	000001
9:4	Microsemi model number	RO	VSC8541-01	110111
3:0	Device revision number	RO	Revision B	0001

## 4.2.4 Auto-Negotiation Advertisement

The bits in address 4 in the main registers space control the ability to notify other devices of the status of its auto-negotiation feature. The following table shows the available settings and readouts.

**Table 25 • Device Auto-Negotiation Advertisement, Address 4 (0x04)**

Bit	Name	Access	Description	Default
15	Next page transmission request	R/W	1: Request enabled	0
14	Reserved	RO	Reserved	
13	Transmit remote fault	R/W	1: Enabled	0
12	Reserved	R/W	Reserved	0
11	Advertise asymmetric pause	R/W	1: Advertises asymmetric pause	0
10	Advertise symmetric pause	R/W	1: Advertises symmetric pause	0
9	Advertise100BASE-T4	R/W	1: Advertises 100BASE-T4	0
8	Advertise100BASE-TX FDX	R/W	1: Advertise 100BASE-TX FDX	1
7	Advertise100BASE-TX HDX	R/W	1: Advertises 100BASE-TX HDX	1
6	Advertise10BASE-T FDX	R/W	1: Advertises 10BASE-T FDX	1
5	Advertise10BASE-T HDX	R/W	1: Advertises 10BASE-T HDX	1
4:0	Advertise selector	R/W		00001

## 4.2.5 Link Partner Auto-Negotiation Capability

The bits in main register 5 can be used to determine if the Cat5 link partner (LP) used with the VSC8541-01 device is compatible with the auto-negotiation functionality.

**Table 26 • Auto-Negotiation Link Partner Ability, Address 5 (0x05)**

Bit	Name	Access	Description	Default
15	LP next page transmission request	RO	1: Requested	0
14	LP acknowledge	RO	1: Acknowledge	0
13	LP remote fault	RO	1: Remote fault	0
12	Reserved	RO	Reserved	
11	LP advertise asymmetric pause	RO	1: Capable of asymmetric pause	0
10	LP advertise symmetric pause	RO	1: Capable of symmetric pause	0
9	LP advertise 100BASE-T4	RO	1: Capable of 100BASE-T4	0
8	LP advertise 100BASE-TX FDX	RO	1: Capable of 100BASE-TX FDX	0
7	LP advertise 100BASE-TX HDX	RO	1: Capable of 100BASE-TX HDX	0
6	LP advertise 10BASE-T FDX	RO	1: Capable of 10BASE-T FDX	0
5	LP advertise 10BASE-T HDX	RO	1: Capable of 10BASE-T HDX	0
4:0	LP advertise selector	RO		00000

## 4.2.6 Auto-Negotiation Expansion

The bits in main register 6 work together with those in register 5 to indicate the status of the LP auto-negotiation functioning. The following table shows the available settings and readouts.

**Table 27 • Auto-Negotiation Expansion, Address 6 (0x06)**

Bit	Name	Access	Description	Default
15:5	Reserved	RO	Reserved.	
4	Parallel detection fault	RO	This bit latches high. 1: Parallel detection fault.	0
3	LP next page capable	RO	1: LP is next page capable.	0
2	Local PHY next page capable	RO	1: Local PHY is next page capable.	1
1	Page received	RO	This bit latches high. 1: New page is received.	0
0	LP is autonegotiation capable	RO	1: LP is capable of auto-negotiation.	0

## 4.2.7 Transmit Auto-Negotiation Next Page

The settings in register 7 in the main registers space provide information about the number of pages in an auto-negotiation sequence. The following table shows the settings available.

**Table 28 • Auto-Negotiation Next Page Transmit, Address 7 (0x07)**

Bit	Name	Access	Description	Default
15	Next page	R/W	1: More pages follow.	0
14	Reserved	RO	Reserved.	
13	Message page	R/W	1: Message page. 0: Unformatted page.	1
12	Acknowledge 2	R/W	1: Complies with request. 0: Cannot comply with request.	0
11	Toggle	RO	1: Previous transmitted LCW = 0. 0: Previous transmitted LCW = 1.	0
10:0	Message/unformatted code	R/W		0000000001

## 4.2.8 Auto-Negotiation Link Partner Next Page Receive

The bits in register 8 of the main register space work together with register 7 to determine certain aspects of the LP auto-negotiation. The following table shows the possible readouts.

**Table 29 • Auto-Negotiation LP Next Page Receive, Address 8 (0x08)**

Bit	Name	Access	Description	Default
15	LP next page	RO	1: More pages follow.	0
14	Acknowledge	RO	1: LP acknowledge.	0
13	LP message page	RO	1: Message page. 0: Unformatted page.	0
12	LP acknowledge 2	RO	1: LP complies with request.	0
11	LP toggle	RO	1: Previous transmitted LCW = 0. 0: Previous transmitted LCW = 1.	0
10:0	LP message/unformatted code	RO		All zeros

## 4.2.9 1000BASE-T Control

The 1000BASE-T functionality is controlled by the bits in register 9 of the main register space. The following table shows the settings and readouts available.

**Table 30 • 1000BASE-T Control, Address 9 (0x09)**

Bit	Name	Access	Description	Default
15:13	Transmitter test mode	R/W	000: Normal. 001: Mode 1: Transmit waveform test. 010: Mode 2: Transmit jitter test as master. 011: Mode 3: Transmit jitter test as slave. 100: Mode 4: Transmitter distortion test. 101–111: Reserved.	000
12	Master/slave manual configuration	R/W	1: Master/slave manual configuration enabled.	0
11	Master/slave value	R/W	This register is only valid when bit 9.12 is set to 1. 1: Configure PHY as master during negotiation. 0: Configure PHY as slave during negotiation.	0
10	Port type	R/W	1: Multi-port device. 0: Single-port device.	0
9	1000BASE-T FDX capability	R/W	1: PHY is 1000BASE-T FDX capable.	1
8	1000BASE-T HDX capability	R/W	1: PHY is 1000BASE-T HDX capable.	1
7:0	Reserved	RO	Reserved.	

**Note:** Transmitter test mode (bits 15:13) operates in the manner described in IEEE 802.3 section 40.6.1.1.2.

## 4.2.10 1000BASE-T Status

The bits in register 10 of the main register space can be read to obtain the status of the 1000BASE-T communications enabled in the device. The following table shows the readouts.

**Table 31 • 1000BASE-T Status, Address 10 (0x0A)**

Bit	Name	Access	Description	Default
15	Master/slave configuration fault	RO	This bit latches high; self-clearing. 1: Master/slave configuration fault detected. 0: No master/slave configuration fault detected.	0
14	Master/slave configuration resolution	RO	1: Local PHY configuration resolved to master. 0: Local PHY configuration resolved to slave.	1
13	Local receiver status	RO	1: Local receiver is operating normally.	0
12	Remote receiver status	RO	1: Remote receiver OK.	0
11	LP 1000BASE-T FDX capability	RO	1: LP 1000BASE-T FDX capable.	0
10	LP 1000BASE-T HDX capability	RO	1: LP 1000BASE-T HDX capable.	0
9:8	Reserved	RO	Reserved.	
7:0	Idle error count	RO	Self-clearing register.	0x00

## 4.2.11 MMD Access Control Register

The bits in register 13 of the main register space are a window to the EEE registers as defined in IEEE 802.3az-2010 Clause 45.

**Table 32 • MMD EEE Access, Address 13 (0x0D)**

Bit	Name	Access	Description
15:14	Function	R/W	00: Address. 01: Data, no post increment. 10: Data, post increment for read and write. 11: Data, post increment for write only.
13:5	Reserved	RO	Reserved.
4:0	DVAD	R/W	Device address as defined in IEEE 802.3az-2010 table 45–1.

## 4.2.12 MMD Address or Data Register

The bits in register 14 of the main register space are a window to the EEE registers as defined in IEEE 802.3az-2010 Clause 45.

**Table 33 • MMD Address or Data Register, Address 14 (0x0E)**

Bit	Name	Access	Description
15:0	Register Address/Data	R/W	When register 13.15:14 = 2'b00, address of register of the device that is specified by 13.4:0. Otherwise, the data to be written to or read from the register.

## 4.2.13 1000BASE-T Status Extension 1

Register 15 provides additional information about the operation of the device 1000BASE-T communications. The following table shows the readouts available.

**Table 34 • 1000BASE-T Status Extension 1, Address 15 (0x0F)**

Bit	Name	Access	Description	Default
15	Reserved	RO	Reserved	
14	1000BASE-X HDX capability	RO	1: PHY is 1000BASE-X HDX capable	0
13	1000BASE-T FDX capability	RO	1: PHY is 1000BASE-T FDX capable	1
12	1000BASE-T HDX capability	RO	1: PHY is 1000BASE-T HDX capable	1
11:0	Reserved	RO	Reserved	

## 4.2.14 100BASE-TX Status Extension

Register 16 in the main registers page space provides additional information about the status of the 100BASE-TX operation.

**Table 35 • 100BASE-TX Status Extension, Address 16 (0x10)**

Bit	Name	Access	Description	Default
15	100BASE-TX Descrambler	RO	1: Descrambler locked.	0
14	100BASE-TX lock error	RO	Self-clearing bit. 1: Lock error detected.	0
13	100BASE-TX disconnect state	RO	Self-clearing bit. 1: PHY 100BASE-TX link disconnect detected.	0

**Table 35 • 100BASE-TX Status Extension, Address 16 (0x10) (continued)**

Bit	Name	Access	Description	Default
12	100BASE-TX current link status	RO	1: PHY 100BASE-TX link active.	0
11	100BASE-TX receive error	RO	Self-clearing bit. 1: Receive error detected.	0
10	100BASE-TX transmit error	RO	Self-clearing bit. 1: Transmit error detected.	0
9	100BASE-TX SSD error	RO	Self-clearing bit. 1: Start-of-stream delimiter error detected.	0
8	100BASE-TX ESD error	RO	Self-clearing bit. 1: End-of-stream delimiter error detected.	0
7:0	Reserved	RO	Reserved.	

## 4.2.15 1000BASE-T Status Extension 2

The second status extension register is at address 17 in the device main registers space. It provides information about another set of parameters associated with 1000BASE-T communications. For information about the first status extension register, see [Table 34](#), page 36.

**Table 36 • 1000BASE-T Status Extension 2, Address 17 (0x11)**

Bit	Name	Access	Description	Default
15	1000BASE-T descrambler	RO	1: Descrambler locked.	0
14	1000BASE-T lock error	RO	Self-clearing bit. 1: Lock error detected.	0
13	1000BASE-T disconnect state	RO	Self-clearing bit. 1: PHY 1000BASE-T link disconnect detected.	0
12	1000BASE-T current link status	RO	1: PHY 1000BASE-T link active.	0
11	1000BASE-T receive error	RO	Self-clearing bit. 1: Receive error detected.	0
10	1000BASE-T transmit error	RO	Self-clearing bit. 1: Transmit error detected.	0
9	1000BASE-T SSD error	RO	Self-clearing bit. 1: Start-of-stream delimiter error detected.	0
8	1000BASE-T ESD error	RO	Self-clearing bit. 1: End-of-stream delimiter error detected.	0
7	1000BASE-T carrier extension error	RO	Self-clearing bit. 1: Carrier extension error detected.	0
6	Non-compliant BCM5400 detected	RO	1: Non-compliant BCM5400 link partner detected.	0
5	MDI crossover error	RO	1: MDI crossover error was detected.	0
4:0	Reserved	RO	Reserved.	

## 4.2.16 Bypass Control

The bits in this register control aspects of functionality in effect when the device is disabled for the purpose of traffic bypass. The following table shows the settings available.

**Table 37 • Bypass Control, Address 18 (0x12)**

Bit	Name	Access	Description	Default
15	Transmit disable	R/W	1: PHY transmitter disabled.	0
14	4B5B encoder/decoder	R/W	1: Bypass 4B/5B encoder/decoder.	0
13	Scrambler	R/W	1: Bypass scrambler.	0
12	Descrambler	R/W	1: Bypass descrambler.	0
11	PCS receive	R/W	1: Bypass PCS receiver.	0
10	PCS transmit	R/W	1: Bypass PCS transmit.	0
9	LFI timer	R/W	1: Bypass Link Fail Inhibit (LFI) timer.	0
8	Reserved	RO	Reserved.	
7	HP Auto-MDIX at forced 10/100	R/W	Sticky bit. 1: Disable HP Auto-MDIX at forced 10/100 speeds.	1
6	Non-compliant BCM5400 detect disable	R/W	Sticky bit. 1: Disable non-compliant BCM5400 detection.	0
5	Disable pair swap correction (HP Auto-MDIX when autonegotiation enabled)	R/W	Sticky bit. 1: Disable the automatic pair swap correction.	0
4	Disable polarity correction	R/W	Sticky bit. 1: Disable polarity inversion correction on each subchannel.	0
3	Parallel detect control	R/W	Sticky bit. 1: Do not ignore advertised ability. 0: Ignore advertised ability.	1
2	Pulse shaping filter	R/W	1: Disable pulse shaping filter.	0
1	Disable automatic 1000BASE-T next page exchange	R/W	Sticky bit. 1: Disable automatic 1000BASE T next page exchanges.	0
0	Reserved	RO	Reserved.	

**Note:** If bit 18.1 is set to 1 in this register, automatic exchange of next pages is disabled, and control is returned to the user through the SMI after the base page is exchanged. The user then must send the correct sequence of next pages to the link partner, determine the common capabilities, and force the device into the correct configuration following the successful exchange of pages.

## 4.2.17 Error Counter 1

The bits in register 19 provide an error counter. The following table shows the settings available.

**Table 38 • Extended Control and Status, Address 19 (0x13)**

Bit	Name	Access	Description	Default
15:8	Reserved	RO	Reserved.	
7:0	100/1000 receive error counter	RO	8-bit counter that saturates when it reaches 255. These bits are self-clearing when read.	0x00

## 4.2.18 Error Counter 2

The bits in register 20 provide an error counter. The following table shows the settings available.

**Table 39 • Extended Control and Status, Address 20 (0x14)**

Bit	Name	Access	Description	Default
15:8	Reserved	RO	Reserved.	
7:0	100/1000 false carrier counter	RO	8-bit counter that saturates when it reaches 255. These bits are self-clearing when read.	0x00

## 4.2.19 Error Counter 3

The bits in register 21 provide an error counter. The following table shows the settings available.

**Table 40 • Extended Control and Status, Address 21 (0x15)**

Bit	Name	Access	Description	Default
15:8	Reserved	RO	Reserved.	
7:0	Copper media link disconnect counter	RO	8-bit counter that saturates when it reaches 255. These bits are self-clearing when read.	0x00

## 4.2.20 Extended Control and Status

The bits in register 22 provide additional device control and readouts. The following table shows the settings available.

**Table 41 • Extended Control and Status, Address 22 (0x16)**

Bit	Name	Access	Description	Default
15	Force 10BASE-T link high	R/W	Sticky bit. 1: Bypass link integrity test. 0: Enable link integrity test.	0
14	Jabber detect disable	R/W	Sticky bit. 1: Disable jabber detect.	0
13	Disable 10BASE-T echo	R/W	Sticky bit. 1: Disable 10BASE-T echo.	1
12	Disable SQE mode	R/W	Sticky bit. 1: Disable SQE mode.	1
11:10	10BASE-T squelch control	R/W	Sticky bit. 00: Normal squelch. 01: Low squelch. 10: High squelch. 11: Reserved.	00
9	Sticky reset enable	R/W	Super-sticky bit. 1: Enabled.	1
8	EOF Error	RO	This bit is self-clearing. 1: EOF error detected.	0
7	10BASE-T disconnect state	RO	This bit is self-clearing. 1: 10BASE-T link disconnect detected.	0
6	10BASE-T link status	RO	1: 10BASE-T link active.	0
5:1	Reserved	RO	Reserved.	

**Table 41 • Extended Control and Status, Address 22 (0x16) (continued)**

Bit	Name	Access	Description	Default
0	SMI broadcast write	R/W	Sticky bit. 1: Enabled.	0

The following information applies to the extended control and status bits:

- When bit 22.15 is set, the link integrity state machine is bypassed and the PHY is forced into a link pass status.
- When bits 22.11:10 are set to 00, the squelch threshold levels are based on the IEEE standard for 10BASE-T. When set to 01, the squelch level is decreased, which can improve the bit error rate performance on long loops. When set to 10, the squelch level is increased and can improve the bit error rate in high-noise environments.
- When bit 22.9 is set, all sticky register bits retain their values during a software reset. Clearing this bit causes all sticky register bits to change to their default values upon software reset. Super-sticky bits retain their values upon software reset regardless of the setting of bit 22.9.
- When bit 22.0 is set, if a write to any PHY register (registers 0–31, including extended registers), the same write is broadcast to all PHYs. For example, if bit 22.0 is set to 1 and a write to PHY0 is executed (register 0 is set to 0x1040), all PHYs' register 0s are set to 0x1040. Disabling this bit restores normal PHY write operation. Reads are still possible when this bit is set, but the value that is read corresponds only to the particular PHY being addressed.

## 4.2.21 Extended PHY Control 1

The following table shows the settings available.

**Table 42 • Extended PHY Control 1, Address 23 (0x17)**

Bit	Name	Access	Description	Default
15:14	Reserved	RO	Reserved.	
13	MAC supplied clock enable	R/W	MAC interface RX_CLK synchronization. 0: Synchronize RX_CLK to recovered clock. 1: Synchronize RX_CLK to REFCLK. <b>Note:</b> This bit is not applicable to the RMII MAC interface selection. This bit may be changed during COMA mode or written prior to a soft-reset, after which it takes effect.	0
12:11	MAC interface selection	R/W	MAC interface mode. 00: GMII/MII. 01: RMII. 10: RGMII. 11: Reserved. <b>Note:</b> These bits may be changed during COMA mode or written prior to a soft-reset, after which it takes effect.	10
10:4	Reserved	RO	Reserved.	
3	Far-end loopback mode	R/W	1: Enabled.	0
2:0	Reserved	RO	Reserved.	

**Note:** After configuring bits 13:11 of the extended PHY control register set 1, a software reset (register 0, bit 15) must be written to change the device operating mode. On read, these bits only indicate the actual operating mode and not the pending operating mode setting before a software reset has taken place.

## 4.2.22 Extended PHY Control 2

The second set of extended controls is located in register 24 in the main register space for the device. The following table shows the settings and readouts available.

**Table 43 • Extended PHY Control 2, Address 24 (0x18)**

Bit	Name	Access	Description	Default
15:13	100BASE-TX edge rate control	R/W	Sticky bit. 011: +7 edge rate (slowest). 010: +6 edge rate. 001: +5 edge rate. 000: +4 edge rate. 111: +3 edge rate. 110: +2 edge rate. 101: +1 edge rate. 100: Fastest edge rate.	000
12	PICMG 2.16 reduced power mode	R/W	Sticky bit. 1: Enabled.	0
11:6	Reserved	RO	Reserved.	
5:4	Jumbo packet mode	R/W	Sticky bit. 00: Normal IEEE 1.5 kB packet length. 01: 9 kB jumbo packet length (12 kB with 60 ppm or better reference clock). 10: 12 kB jumbo packet length (16 kB with 70 ppm or better reference clock). 11: Reserved.	00
3:1	Reserved	RO	Reserved.	
0	1000BASE-T connector loopback	R/W	1: Enabled.	0

**Note:** When bits 5:4 are set to jumbo packet mode, the default maximum packet values are based on 100 ppm driven reference clock to the device. Controlling the ppm offset between the MAC and the PHY as specified in the bit description results in a higher jumbo packet length.

## 4.2.23 Interrupt Mask

These bits control the device interrupt mask. The following table shows the settings available.

**Table 44 • Interrupt Mask, Address 25 (0x19)**

Bit	Name	Access	Description	Default
15	MDINT interrupt status enable	R/W	Sticky bit. 1: Enabled.	0
14	Speed state change mask	R/W	Sticky bit. 1: Enabled.	0
13	Link state change mask	R/W	Sticky bit. 1: Enabled.	0
12	FDX state change mask	R/W	Sticky bit. 1: Enabled.	0
11	Autonegotiation error mask	R/W	Sticky bit. 1: Enabled.	0
10	Autonegotiation complete mask	R/W	Sticky bit. 1: Enabled.	0
9	Inline-powered device (PoE) detect mask	R/W	Sticky bit. 1: Enabled.	0
8	Symbol error interrupt mask	R/W	Sticky bit. 1: Enabled.	0
7	Fast link failure interrupt mask	R/W	Sticky bit. 1: Enabled.	0
6	Wake-on-LAN event interrupt mask	R/W	Sticky bit. 1: Enabled.	0
5	Extended interrupt mask	R/W	Sticky bit. 1: Enabled.	0

**Table 44 • Interrupt Mask, Address 25 (0x19) (continued)**

Bit	Name	Access	Description	Default
4	Reserved	R/W	Reserved.	0
3	False carrier interrupt mask	R/W	Sticky bit. 1: Enabled.	0
2	Link speed downshift detect mask	R/W	Sticky bit. 1: Enabled.	0
1	Master/Slave resolution error mask	R/W	Sticky bit. 1: Enabled.	0
0	RX_ER interrupt mask	R/W	Sticky bit. 1: Enabled.	0

**Note:** When bit 25.15 is set, the MDINT pin is enabled. When enabled, the state of this pin reflects the state of bit 26.15. Clearing this bit only inhibits the MDINT pin from being asserted. Also, before enabling this bit, read register 26 to clear any previously inactive interrupts pending that will cause bit 25.15 to be set.

## 4.2.24 Interrupt Status

The status of interrupts already written to the device is available for reading from register 26 in the main registers space. The following table shows the expected readouts.

**Table 45 • Interrupt Status, Address 26 (0x1A)**

Bit	Name	Access	Description	Default
15	Interrupt status	RO	Self-clearing bit. 1: Interrupt pending.	0
14	Speed state change status	RO	Self-clearing bit. 1: Interrupt pending.	0
13	Link state change status	RO	Self-clearing bit. 1: Interrupt pending.	0
12	FDX state change status	RO	Self-clearing bit. 1: Interrupt pending.	0
11	Autonegotiation error status	RO	Self-clearing bit. 1: Interrupt pending.	0
10	Autonegotiation complete status	RO	Self-clearing bit. 1: Interrupt pending.	0
9	Inline powered device detect status	RO	Self-clearing bit. 1: Interrupt pending.	0
8	Symbol error status	RO	Self-clearing bit. 1: Interrupt pending.	0
7	Fast link failure detect status	RO	Self-clearing bit. 1: Interrupt pending.	0
6	Wake-on-LAN event status	RO	Self-clearing bit. 1: Interrupt pending.	0
5	Extended interrupt status	RO	Self-clearing bit. 1: Interrupt pending.	0
4	Reserved	RO	Reserved.	
3	False carrier interrupt status	RO	Self-clearing bit. 1: Interrupt pending.	0
2	Link speed downshift detect status	RO	Self-clearing bit. 1: Interrupt pending.	0
1	Master/Slave resolution error status	RO	Self-clearing bit. 1: Interrupt pending.	0
0	RX_ER interrupt status	RO	Self-clearing bit. 1: Interrupt pending.	0

The following information applies to the interrupt status bits:

- All set bits in this register are cleared after being read (self-clearing). If bit 26.15 is set, the cause of the interrupt can be read by reading bits 26.14:0.
- For bits 26.14 and 26.12, bit 0.12 must be set for this interrupt to assert.
- For bit 26.2, bits 4.8:5 must be set for this interrupt to assert.
- For bit 26.0, this interrupt will not occur when RX\_ER is used for carrier-extension decoding of a link partner's data transmission.
- If bit 5 is set, register 29E2 must be read to determine the source of the interrupt.

## 4.2.25 Device Auxiliary Control and Status

Register 28 provides control and status information for several device functions not controlled or monitored by other device registers. The following table shows the settings available and the expected readouts.

**Table 46 • Auxiliary Control and Status, Address 28 (0x1C)**

Bit	Name	Access	Description	Default
15	Autonegotiation complete	RO	Duplicate of bit 1.5 when auto-negotiation is enabled, otherwise this is the current link status.	0
14	Autonegotiation disabled	RO	Inverted duplicate of bit 0.12.	0
13	HP Auto-MDIX crossover indication	RO	1: HP Auto-MDIX crossover performed internally.	0
12	CD pair swap	RO	1: CD pairs are swapped.	0
11	A polarity inversion	RO	1: Polarity swap on pair A.	0
10	B polarity inversion	RO	1: Polarity swap on pair B.	0
9	C polarity inversion	RO	1: Polarity swap on pair C.	0
8	D polarity inversion	RO	1: Polarity swap on pair D.	0
7	ActiPHY link status time-out control [1]	R/W	Sticky bit. Bits 7 and 2 are part of the ActiPHY Link Status time-out control. Bit 7 is the MSB. 00: 2.3 seconds. 01: 3.3 seconds. 10: 4.3 seconds. 11: 5.3 seconds.	0
6	ActiPHY mode enable	R/W	Sticky bit. 1: Enabled.	0
5	FDX status	RO	1: Full-duplex. 0: Half-duplex.	0
4:3	Speed status	RO	00: Speed is 10BASE-T. 01: Speed is 100BASE-TX. 10: Speed is 1000BASE-T. 11: Reserved.	00
2	ActiPHY link status time-out control [0]	R/W	Sticky bit. Bits 7 and 2 are part of the ActiPHY Link Status time-out control. Bit 7 is the MSB. 00: 2.3 seconds. 01: 3.3 seconds. 10: 4.3 seconds. 11: 5.3 seconds.	1
1:0	Media mode status	RO	00: No media selected. 01: Copper media selected. 10: Reserved. 11: Reserved.	00

## 4.2.26 LED Mode Select

The device LED outputs are controlled using the bits in register 29 of the main register space. The following table shows the information needed to access the functionality of each of the outputs. For more

information about LED modes, see [Table 14](#), page 21. For information about enabling the extended LED mode bits in Register 19E1 bits 13 to 12, see [Table 16](#), page 22.

**Table 47 • LED Mode Select, Address 29 (0x1D)**

Bit	Name	Access	Description	Default
15	Reserved	RO	Reserved.	
14:8	Reserved	R/W	Reserved.	0x00
7:4	LED1 mode select	R/W	Sticky bit. Select from LED modes 0–15.	0010
3:0	LED0 mode select	R/W	Sticky bit. Select from LED modes 0–15.	0001

## 4.2.27 LED Behavior

The bits in register 30 control and enable you to read the status of the pulse or blink rate of the device LEDs. The following table shows the settings you can write to the register or read from the register.

**Table 48 • LED Behavior, Address 30 (0x1E)**

Bit	Name	Access	Description	Default
15:13	Reserved	RO	Reserved.	
12	LED pulsing enable	R/W	Sticky bit. 0: Normal operation. 1: LEDs pulse with a 5 kHz, programmable duty cycle when active.	0
11:10	LED blink/pulse-stretch rate	R/W	Sticky bit. 00: 2.5 Hz blink rate/400 ms pulse-stretch. 01: 5 Hz blink rate/200 ms pulse-stretch. 10: 10 Hz blink rate/100 ms pulse-stretch. 11: 20 Hz blink rate/50 ms pulse-stretch. The blink rate selection sets the rate used for all LED pins.	01
9:7	Reserved	RO	Reserved.	
6	LED1 pulse-stretch/blink select	R/W	Sticky bit. 1: Pulse-stretch. 0: Blink.	0
5	LED0 pulse-stretch/blink select	R/W	Sticky bit. 1: Pulse-stretch. 0: Blink.	0
4:2	Reserved	RO	Reserved.	
1	LED1 combine feature disable	R/W	Sticky bit. 0: Combine enabled (link/activity, duplex/collision). 1: Disable combination (link only, duplex only).	0
0	LED0 combine feature disable	R/W	Sticky bit. 0: Combine enabled (link/activity, duplex/collision). 1: Disable combination (link only, duplex only).	0

**Note:** Bits 30.11:10 are active only in port 0 and affect the behavior of LEDs for all the ports.

## 4.2.28 Extended Page Access

To provide functionality beyond the IEEE 802.3-specified registers and main device registers, an extended set of registers provide an additional 15 register spaces.

The register at address 31 controls access to the extended registers. Accessing the GPIO page register space is similar to accessing the extended page registers. The following table shows the settings available.

**Table 49 • Extended/GPIO Register Page Access, Address 31 (0x1F)**

Bit	Name	Access	Description	Default
15:0	Extended/GPIO page register access	R/W	0x0000: Register 16–30 accesses main register space. Writing 0x0000 to register 31 restores the main register access. 0x0001: Registers 16–30 access extended register space 1. 0x0002: Registers 16–30 access extended register space 2. 0x0010: Registers 0–30 access GPIO register space.	0x0000

## 4.3 Extended Page 1 Registers

To access the extended page 1 registers (17E1–30E1), enable extended register access by writing 0x0001 to register 31. Writing 0x0000 to register 31 restores the main register access.

When extended page 1 register access is enabled, reads and writes to registers 16–30 affect the extended registers 17E1–30E1 instead of those same registers in the IEEE-specified register space. Registers 0–15 are not affected by the state of the extended page register access.

**Table 50 • Extended Registers Page 1 Space**

Address	Name
18E1	Cu Media CRC Good Counter
19E1	Extended Mode Control
20E1	Extended PHY Control 3 (ActiPHY)
21E1–22E1	Reserved
23E1	Extended PHY Control 4 (PoE and CRC Error Counter)
27E1–28E1	Reserved
29E1	Ethernet Packet Generator (EPG) 1
30E1	EPG 2

### 4.3.1 Cu Media CRC Good Counter

Register 18E1 makes it possible to read the contents of the CRC good counter for packets that are received on the Cu media interface: the number of CRC routines that have executed successfully. The following table shows the expected readouts.

**Table 51 • Cu Media CRC Good Counter, Address 18E1 (0x12)**

Bit	Name	Access	Description	Default
15	Packet since last read	RO	Self-clearing bit. 1: Packet received since last read.	0
14	Reserved	RO	Reserved.	
13:0	Cu Media CRC good counter contents	RO	Self-clearing bit. Counter containing the number of packets with valid CRCs modulo 10,000; this counter does not saturate and will roll over to zero on the next good packet received after 9,999.	0x0000

### 4.3.2 Extended Mode Control

Register 19E1 controls the extended LED and other chip modes. The following table shows the settings available.

**Table 52 • Extended Mode Control, Address 19E1 (0x13)**

Bit	Name	Access	Description	Default
15:14	Reserved	R/W	Reserved.	00
13	LED1 Extended Mode	R/W	Sticky bit. 1: See <a href="#">Basic Serial LED Mode</a> , page 21.	0
12	LED0 Extended Mode	R/W	Sticky bit. 1: See <a href="#">Basic Serial LED Mode</a> , page 21.	0
11	LED Reset Blink Suppress	R/W	Sticky bit. 1: Blink LEDs after COMA_MODE is de-asserted. 0: Suppress LED blink after COMA_MODE is de-asserted.	0
10:5	Reserved	RO	Reserved.	
4	Fast link failure	R/W	Sticky bit. Enable fast link failure pin. 1: Enabled. 0: Disabled.	1
3:2	Force MDI crossover	R/W	Sticky bit. 00: Normal HP Auto-MDIX operation. 01: Reserved. 10: Copper media forced to MDI. 11: Copper media forced MDI-X.	00
1	Reserved	RO	Reserved.	
0	Reserved	R/W	Reserved.	0

### 4.3.3 ActiPHY Control

Register 20E1 controls the device ActiPHY sleep timer, its wake-up timer, and its link speed downshifting feature. The following table shows the settings available.

**Table 53 • Extended PHY Control 3, Address 20E1 (0x14)**

Bit	Name	Access	Description	Default
15	Disable carrier extension	R/W	1: Disable carrier extension in 1000BASE-T copper links.	1
14:13	ActiPHY sleep timer	R/W	Sticky bit. 00: 1 second. 01: 2 seconds. 10: 3 seconds. 11: 4 seconds.	01
12:11	ActiPHY wake-up timer	R/W	Sticky bit. 00: 160 ms. 01: 400 ms. 10: 800 ms. 11: 2 seconds.	00

**Table 53 • Extended PHY Control 3, Address 20E1 (0x14) (continued)**

Bit	Name	Access	Description	Default
10	Slow MDC	R/W	Sticky bit. 1: Indicates that MDC runs at less than 1 MHz (use of this bit is optional and indicated when MDC runs at less than 1 MHz).	0
9:8	Reserved	RO	Reserved.	
7:6	Media mode status	RO	00: No media selected. 01: Copper media selected. 10: Reserved. 11: Reserved.	00
5	Enable 10BASE-T no preamble mode	R/W	Sticky bit. 1: 10BASE-T will assert RX_DV indication when data is presented to the receiver even without a preamble preceding it.	0
4	Enable link speed autoshift feature	R/W	Sticky bit. 1: Enable auto link speed downshift from 1000BASE-T.	0
3:2	Link speed auto downshift control	R/W	Sticky bit. 00: Downshift after 2 failed 1000BASE-T auto-negotiation attempts. 01: Downshift after 3 failed 1000BASE-T auto-negotiation attempts. 10: Downshift after 4 failed 1000BASE-T auto-negotiation attempts. 11: Downshift after 5 failed 1000BASE-T auto-negotiation attempts.	01
1	Link speed auto downshift status	RO	0: No downshift. 1: Downshift is required or has occurred.	0
0	Reserved	RO	Reserved.	

#### 4.3.4 PoE and Miscellaneous Functionality

The register at address 23E1 controls various aspects of inline-powering and the CRC error counter in the VSC8541-01 device.

**Table 54 • Extended PHY Control 4, Address 23E1 (0x17)**

Bit	Name	Access	Description	Default
15:11	PHY address	RO	Internal PHY address: 0–31.	
10	Inline powered device detection	R/W	Sticky bit. 1: Enabled.	0
9:8	Inline powered device detection status	RO	Only valid when bit 10 is set. 00: Searching for devices. 01: Device found; requires inline-power. 10: Device found; does not require inline-power. 11: Reserved.	00
7:0	Cu Media CRC error counter	RO	Self-clearing 8-bit error count register.	

### 4.3.5 Ethernet Packet Generator (EPG) Control 1

The EPG control register provides access to and control of various aspects of the EPG testing feature. There are two separate EPG control registers. The following table shows the settings available in the first register.

**Table 55 • EPG Control Register 1, Address 29E1 (0x1D)**

Bit	Name	Access	Description	Default
15	EPG enable <sup>1</sup>	R/W	1: Enable EPG.	0
14	EPG run or stop	R/W	1: Run EPG.	0
13	Transmission duration	R/W	1: Continuous (sends in 10,000-packet increments). 0: Send 30,000,000 packets and stop.	0
12:11	Packet length	R/W	00: 125 bytes. 01: 64 bytes. 10: 1518 bytes. 11: 10,000 bytes (jumbo packet).	00
10	Interpacket gap	R/W	1: 8,192 ns. 0: 96 ns.	0
9:6	Destination address	R/W	Lowest nibble of the 6-byte destination address.	0001
5:2	Source address	R/W	Lowest nibble of the 6-byte destination address.	0000
1	Payload type	R/W	1: Randomly generated payload pattern. 0: Fixed based on payload pattern.	0
0	Bad frame check sequence (FCS) generation	R/W	1: Generate packets with bad FCS. 0: Generate packets with good FCS.	0

- To end forced transmission of EEE LPIs from the PHY, clear the force EEE LPI bit (17E2.4) first before clearing the EPG enable bit (29E1.15).

The following information applies to the EPG control number 1:

- Do not run the EPG when the VSC8541-01 device is connected to a live network.
- Bit 29E1.13 (continuous EPG mode control): when enabled, this mode causes the device to send continuous packets. When disabled, the device continues to send packets only until it reaches the next 10,000-packet increment mark. It then ceases to send packets.
- The 6-byte destination address in bits 9:6 is assigned one of 16 addresses in the range of 0xFF FF FF FF F0 through 0xFF FF FF FF FF.
- The 6-byte source address in bits 5:2 is assigned one of 16 addresses in the range of 0xFF FF FF FF F0 through 0xFF FF FF FF FF.
- If any of bits 13:0 are changed while the EPG is running (bit 14 is set to 1), bit 14 must be cleared and then set back to 1 for the change to take effect and to restart the EPG.

### 4.3.6 Ethernet Packet Generator Control 2

Register 30E1 consists of the second set of bits that provide access to and control over the various aspects of the EPG testing feature. The following table shows the settings available.

**Table 56 • EPG Control Register 2, Address 30E1 (0x1E)**

Bit	Name	Access	Description	Default
15:0	EPG packet payload	R/W	Data pattern repeated in the payload of packets generated by the EPG	0x0000

**Note:** If any of bits 15:0 in this register are changed while the EPG is running (bit 14 of register 29E1 is set to 1), that bit (29E1.14) must first be cleared and then set back to 1 for the change to take effect and to restart the EPG.

## 4.4 Extended Page 2 Registers

To access the extended page 2 registers (16E2–30E2), enable extended register access by writing 0x0002 to register 31. For more information, see [Table 49](#), page 45.

When extended page 2 register access is enabled, reads and writes to registers 16–30 affect the extended registers 16E2–30E2 instead of those same registers in the IEEE-specified register space. Registers 0–15 are not affected by the state of the extended page register access.

Writing 0x0000 to register 31 restores the main register access.

The following table lists the addresses and register names in the extended register page 2 space. These registers are accessible only when the device register 31 is set to 0x0002.

**Table 57 • Extended Registers Page 2 Space**

Address	Name
16E2	Cu PMD Transmit Control
17E2	EEE Control
18E2–19E2	Reserved
20E2	RGMII Control
21E2	Wake-on-LAN MAC Address [15:0]
22E2	Wake-on-LAN MAC Address [31:16]
23E2	Wake-on-LAN MAC Address [47:32]
24E2	Secure-On Password [15:0]
25E2	Secure-On Password [31:16]
26E2	Secure-On Password [47:32]
27E2	Wake-on-LAN and MAC Interface Control
28E2	Extended Interrupt Mask
29E2	Extended Interrupt Status
30E2	Ring Resiliency Control

### 4.4.1 Cu PMD Transmit Control

The register at address 16E2 consists of the bits that provide control over the amplitude settings for the transmit side Cu PMD interface. These bits provide the ability to make small adjustments in the signal amplitude to compensate for minor variations in the magnetics from different vendors. Extreme caution must be exercised when changing these settings from the default values as they have a direct impact on

the signal quality. Changing these settings also affects the linearity and harmonic distortion of the transmitted signals. For help with changing these values, contact your Microsemi representative.

**Table 58 • Cu PMD Transmit Control, Address 16E2 (0x10)**

Bit	Name	Access	Description	Default
15:12	1000BASE-T signal amplitude trim <sup>1</sup>	R/W	Sticky bit. 1000BASE-T signal amplitude 0000: 1.8% 0001: 2.7% 0010: 3.6% 0011: 4.5% 0100: 5.4% 0101: 6.3% 0110: 7.2% 0111: 8.1% 1000: -8% 1001: -6.2% 1010: -4.4% 1011: -2.7% 1100: -1.8% 1101: -0.9% 1110: 0% 1111: 0.9%	0000
11:8	100BASE-TX signal amplitude trim <sup>2</sup>	R/W	Sticky bit. 100BASE-TX signal amplitude 0000: 1.8% 0001: 2.7% 0010: 3.6% 0011: 4.5% 0100: 5.4% 0101: 6.3% 0110: 7.2% 0111 8.1% 1000: -8% 1001: -6.2% 1010: -4.4% 1011: -2.7% 1100: -1.8% 1101: -0.9% 1110: 0% 1111: 0.9%	0010

**Table 58 • Cu PMD Transmit Control, Address 16E2 (0x10) (continued)**

Bit	Name	Access	Description	Default
7:4	10BASE-T signal amplitude trim <sup>3</sup>	R/W	Sticky bit. 10BASE-T signal amplitude 0000: 0% 0001: 0.9% 0010: 1.8% 0011: 2.7% 0100: 3.6% 0101: 4.5% 0110: 5.4% 0111: 6.1% 1000: -7.2% 1001: -6.3% 1010: -5.4% 1011: -4.5% 1100: -3.6% 1101: -2.7% 1110: -1.8% 1111: -0.9%	1000
3:0	10BASE-Te signal amplitude trim	R/W	Sticky bit. 10BASE-Te signal amplitude 0000: 0% 0001: 0.65% 0010: 1.3% 0011: 1.95% 0100: 2.6% 0101: 3.25% 0110: 3.9% 0111: 4.55% 1000: -5.2% 1001: -4.55% 1010: -3.9% 1011: -3.25% 1100: -2.6% 1101: -1.95% 1110: -1.3% 1111: -0.65%	1110

1. Changes to 1000BASE-T amplitude may result in unpredictable side effects.
2. Adjust 100BASE-TX to specific magnetics.
3. Amplitude is limited by  $V_{CC}$  (2.5 V).

#### 4.4.2 EEE Control

The register at address 17E2 consists of the bits that provide additional control over the chip behavior in energy-efficient Ethernet (IEEE 802.3az-2010) mode for debug.

**Table 59 • EEE Control, Address 17E2 (0x11)**

Bit	Name	Access	Description	Default
15	Enable 10BASE-Te	R/W	Sticky bit. Enable energy efficient (IEEE 802.3az-2010) 10BASE-Te operating mode.	0
14:12	Reserved	RO	Reserved.	

**Table 59 • EEE Control, Address 17E2 (0x11) (continued)**

Bit	Name	Access	Description	Default
11:10	Invert LED polarity	R/W	Sticky bit. Invert polarity of LED signals. Default is to drive an active low signal on the LED pins. For more information, see <a href="#">Extended LED Modes</a> , page 22.	00
9	Reserved	RO	Reserved.	
8	Link status	RO	1: Link is up.	0
7	1000BASE-T EEE enable	RO	1: EEE is enabled for 1000BASE-T.	0
6	100BASE-TX EEE enable	RO	1: EEE is enabled for 100BASE-TX.	0
5	Enable 1000BASE-T force mode	R/W	Sticky bit. 1: Enable 1000BASE-T force mode to allow PHY to link-up in 1000BASE-T mode without forcing master/slave when register 0, bits 6 and 13 are set to 2'b10.	0
4	Force transmit LPI <sup>1</sup>	R/W	Sticky bit. 1: Enable the EPG to transmit LPI on the MDI, ignore data from the MAC interface. 0: Transmit idles being received from the MAC.	0
3	Inhibit 100BASE-TX transmit EEE LPI	R/W	Sticky bit. 1: Disable transmission of EEE LPI on transmit path MDI in 100BASE-TX mode when receiving LPI from MAC.	0
2	Inhibit 100BASE-TX receive EEE LPI	R/W	Sticky bit. 1: Disable transmission of EEE LPI on receive path MAC interface in 100BASE-TX mode when receiving LPI from the MDI.	0
1	Inhibit 1000BASE-T transmit EEE LPI	R/W	Sticky bit. 1: Disable transmission of EEE LPI on transmit path MDI in 1000BASE-T mode when receiving LPI from MAC.	00
0	Inhibit 1000BASE-T receive EEE LPI	R/W	Sticky bit. 1: Disable transmission of EEE LPI on receive path MAC interface in 1000BASE-T mode when receiving LPI from the MDI.	0

1. 17E2 bits 4:0 are for debugging purposes only, not for operational use.

### 4.4.3 RGMII Control

The following table shows the register settings for the RGMII controls at address 20E2.

**Table 60 • RGMII Control, Address 20E2 (0x14)**

Bit	Name	Access	Description	Default
15	FLF2 enable	R/W	Fast Link Failure 2 indication enable. 0: Disabled. 1: Enabled.	0
14:13	Reserved	RO	Reserved.	

**Table 60 • RGMII Control, Address 20E2 (0x14) (continued)**

Bit	Name	Access	Description	Default
12	SOF Enable	R/W	Sticky bit. 0: SOF indication disabled. 1: SOF indication enabled.	0
11:8	Reserved	RO	Reserved.	
7	RGMII/GMII RXD bit reversal	R/W	Sticky bit. When set to 1, makes the following reversed mapping internally: <b>RGMII Mode</b> RXD3 maps to RXD0 RXD2 maps to RXD1 RXD1 maps to RXD2 RXD0 maps to RXD3 <b>GMII/MII Mode</b> RXD7 maps to RXD0 RXD6 maps to RXD1 RXD5 maps to RXD2 RXD4 maps to RXD3 RXD3 maps to RXD4 RXD2 maps to RXD5 RXD1 maps to RXD6 RXD0 maps to RXD7	0
6:4	RX_CLK delay	R/W	Sticky bit. 000: 0.2 ns delay. 001: 0.8 ns delay. 010: 1.1 ns delay. 011: 1.7 ns delay. 100: 2.0 ns delay. 101: 2.3 ns delay. 110: 2.6 ns delay. 111: 3.4 ns delay.	000
3	RGMII/GMII TXD bit reversal	R/W	Sticky bit. When set to 1, makes the following reversed mapping internally: <b>RGMII Mode</b> TXD3 maps to TXD0 TXD2 maps to TXD1 TXD1 maps to TXD2 TXD0 maps to TXD3 <b>GMII/MII Mode</b> TXD7 maps to TXD0 TXD6 maps to TXD1 TXD5 maps to TXD2 TXD4 maps to TXD3 TXD3 maps to TXD4 TXD2 maps to TXD5 TXD1 maps to TXD6 TXD0 maps to TXD7	0

**Table 60 • RGMII Control, Address 20E2 (0x14) (continued)**

Bit	Name	Access	Description	Default
2:0	TX_CLK delay	R/W	Sticky bit. 000: 0.2 ns delay. 001: 0.8 ns delay. 010: 1.1 ns delay. 011: 1.7 ns delay. 100: 2.0 ns delay. 101: 2.3 ns delay. 110: 2.6 ns delay. 111: 3.4 ns delay.	000

#### 4.4.4 Wake-on-LAN MAC Address [15:0]

The following table shows the register settings for the Wake-on-LAN MAC address at 21E2.

**Table 61 • Wake-on-LAN MAC Address, 21E2 (0x15)**

Bit	Name	Access	Description	Default
15:0	WoL MAC address [15:0]	R/W	Sticky bit. WoL MAC address lower two bytes.	0x0000

#### 4.4.5 Wake-on-LAN MAC Address [31:16]

The following table shows the register settings for the Wake-on-LAN MAC address at 22E2.

**Table 62 • Wake-on-LAN MAC Address, 22E2 (0x16)**

Bit	Name	Access	Description	Default
15:0	WoL MAC address [31:16]	R/W	Sticky bit. WoL MAC address middle two bytes.	0x0000

#### 4.4.6 Wake-on-LAN MAC Address [47:32]

The following table shows the register settings for the Wake-on-LAN MAC address at 23E2.

**Table 63 • Wake-on-LAN MAC Address, 23E2 (0x17)**

Bit	Name	Access	Description	Default
15:0	WoL MAC address [47:32]	R/W	Sticky bit. WoL MAC address upper two bytes.	0x0000

#### 4.4.7 Secure-On Password [15:0]

The following table shows the register settings for the Secure-On password used for WoL at 24E2.

**Table 64 • Secure-On Password, 24E2 (0x18)**

Bit	Name	Access	Description	Default
15:0	Secure-On password [15:0]	R/W	Sticky bit. Secure-On password for WoL lower two bytes.	0x0000

#### 4.4.8 Secure-On Password [31:16]

The following table shows the register settings for the Secure-On password used for WoL at 25E2.

**Table 65 • Secure-On Password, 25E2 (0x19)**

Bit	Name	Access	Description	Default
15:0	Secure-On password [31:16]	R/W	Sticky bit. Secure-On password for WoL middle two bytes.	0x0000

#### 4.4.9 Secure-On Password [47:32]

The following table shows the register settings for the Secure-On password used for WoL at 26E2.

**Table 66 • Secure-On Password, 26E2 (0x1A)**

Bit	Name	Access	Description	Default
15:0	Secure-On password [47:32]	R/W	Sticky bit. Secure-On password for WoL upper two bytes.	0x0000

#### 4.4.10 Wake-on-LAN and MAC Interface Control

The following table shows the register settings for the Wake-on-LAN and MAC interface control at address 27E2.

**Table 67 • WoL and MAC Interface Control, Address 27E2 (0x1B)**

Bit	Name	Access	Description	Default
15	Secure-On enable	R/W	Sticky bit. 0: Disabled. 1: Enabled.	0
14	Secure-On password length	R/W	Sticky bit. 0: 6 byte password. 1: 4 byte password.	0
13:12	Reserved	RO	Reserved.	
11:8	Address repetition count in Magic packet	R/W	Sticky bit. Count value: 0000: 1 0001: 2 0010: 3 0011: 4 0100: 5 0101: 6 0110: 7 0111: 8 1000: 9 1001: 10 1010: 11 1011: 12 1100: 13 1101: 14 1110: 15 1111: 16	1111

**Table 67 • WoL and MAC Interface Control, Address 27E2 (0x1B) (continued)**

Bit	Name	Access	Description	Default
7:5	Pad edge rate control	R/W	Sticky bit. MAC interface edge rate control. 000: Slowest edge rate 001: +1 pad edge rate 010: +2 pad edge rate 011: +3 pad edge rate 100: +4 pad edge rate 101: +5 pad edge rate 110: +6 pad edge rate 111: +7 pad edge rate (fastest)	111
4	RMII CLKOUT enable	R/W	Sticky bit. 0: RMII CLKOUT disabled. 1: RMII CLKOUT enabled.	1
3:1	Reserved	RO	Reserved.	
0	MDINT CMOS drive	R/W	Sticky bit. 0: Disabled. 1: Enabled.	0

#### 4.4.11 Extended Interrupt Mask

The following table shows the register settings for the extended interrupt mask at address 28E2.

**Table 68 • Extended Interrupt Mask, Address 28E2 (0x1C)**

Bit	Name	Access	Description	Default
15:14	Reserved interrupt mask	R/W	Reserved.	00
13	Rx FIFO overflow/underflow interrupt mask	R/W	Sticky bit. 1: Enabled.	0
12	Tx FIFO overflow/underflow interrupt mask	R/W	Sticky bit. 1: Enabled.	0
11:5	Reserved interrupt mask	R/W	Reserved.	0x00
4	RR switchover complete interrupt mask	R/W	Sticky bit. 1: Enabled.	0
3	EEE link fail interrupt mask	R/W	Sticky bit. 1: Enabled.	0
2	EEE Rx TQ timer interrupt mask	R/W	Sticky bit. 1: Enabled.	0
1	EEE wait quiet/Rx TS timer interrupt mask	R/W	Sticky bit. 1: Enabled.	0
0	EEE wake error interrupt mask	R/W	Sticky bit. 1: Enabled.	0

#### 4.4.12 Extended Interrupt Status

The following table shows the register settings for the extended interrupt status at address 29E2.

**Table 69 • Extended Interrupt Status, Address 29E2 (0x1D)**

Bit	Name	Access	Description	Default
15:14	Reserved	RO	Reserved.	
13	Rx FIFO overflow/underflow interrupt status	RO	Self-clearing bit. 1: Interrupt pending.	0
12	Tx FIFO overflow/underflow interrupt status	RO	Self-clearing bit. 1: Interrupt pending.	0
11:5	Reserved	RO	Reserved.	

**Table 69 • Extended Interrupt Status, Address 29E2 (0x1D) (continued)**

Bit	Name	Access	Description	Default
4	RR switchover complete interrupt status	RO	Self-clearing bit. 1: Interrupt pending.	0
3	EEE link fail interrupt status	RO	Self-clearing bit. 1: Interrupt pending.	0
2	EEE Rx TQ timer interrupt status	RO	Self-clearing bit. 1: Interrupt pending.	0
1	EEE wait quiet/Rx TS timer interrupt status	RO	Self-clearing bit. 1: Interrupt pending.	0
0	EEE wake error interrupt mask	RO	Self-clearing bit. 1: Interrupt pending.	0

### 4.4.13 Ring Resiliency Control

The following table shows the register settings for the ring resiliency controls at address 30E2.

**Table 70 • Ring Resiliency, Address 30E2 (0x1E)**

Bit	Name	Access	Description	Default
15	Ring resiliency startup enable (master TR enable)	R/W	Sticky.	0
14	Advertise ring resiliency	R/W	Sticky.	0
13	LP ring resiliency advertisement	RO		0
12	Force ring resiliency enable (override autoneg)	R/W	Sticky.	0
11:6	Reserved	RO	Reserved.	
5:4	Ring resiliency status	RO	Ring resiliency status. 00: Timing slave <sup>1</sup> 10: Timing slave becoming master 11: Timing master <sup>1</sup> 01: Timing master becoming slave	00
3:1	Reserved	RO	Reserved.	
0	Start switchover (only when not in progress)	R/W	Self clearing. 1: Initiate timing Master/Slave switchover.	0

1. Reflects autoneg master/slave at initial link-up.

## 4.5 General Purpose Registers

Accessing the general purpose register space is similar to accessing the extended page registers. Set register 31 to 0x0010. This sets all 32 registers to the general purpose register space.

To restore main register page access, write 0x0000 to register 31. All general purpose register bits are super-sticky.

**Table 71 • General Purpose Registers Space**

Address	Name
0G–12G	Reserved
13G	CLKOUT Control

**Table 71 • General Purpose Registers Space (continued)**

Address	Name
14G	GPIO Control 2
15G–18G	Reserved
19G	Fast Link Register
20G–22G	Reserved
23G	Recovered Clock Control
24G	Reserved
25G	Enhanced LED Control
26G–30G	Reserved

### 4.5.1 CLKOUT Control

The CLKOUT control register configures the functionality of the CLKOUT output pin.

**Table 72 • CLKOUT Control, Address 13G (0x0D)**

Bit	Name	Access	Description	Default
15	CLKOUT enable	R/W	1: CLKOUT enabled. 0: CLKOUT disabled.	0
14:13	CLKOUT frequency select	R/W	00: 25 MHz. 01: 50 MHz. 10: 125 MHz. 11: Reserved.	00
12:0	Reserved	R/W	Reserved.	0x0000

### 4.5.2 GPIO Control 2

The GPIO control 2 register configures the functionality of the COMA\_MODE and LED pins.

**Table 73 • GPIO Control 2, Address 14G (0x0E)**

Bit	Name	Access	Description	Default
15:14	Reserved	R/W	Reserved.	00
13	COMA_MODE output enable (active low)	R/W	1: COMA_MODE pin is an input. 0: COMA_MODE pin is an output.	1
12	COMA_MODE output data	R/W	Value to output on the COMA_MODE pin when it is configured as an output.	0
11	COMA_MODE input data	RO	Data read from the COMA_MODE pin.	
10	Reserved	RO	Reserved.	
9	Tri-state enable for LEDs	R/W	1: Tri-state LED output signals instead of driving them high. This allows the signals to be pulled above $V_{DDIO}$ using an external pull-up resistor. 0: Drive LED bus output signals to high and low values.	1
8:0	Reserved	RO	Reserved.	

### 4.5.3 Fast Link Configuration

Register 19G in the GPIO register space controls the selection of the source PHY for the fast link failure indication. The following table shows the settings available for the FASTLINK\_FAIL pin.

**Table 74 • MAC Configuration and Fast Link Register, Address 19G (0x13)**

Bit	Name	Access	Description	Default
15:4	Reserved	RO	Reserved.	
3:0	Fast link failure setting	R/W	0000: Fast link failure pin enabled. 0001–1110: Reserved. 1111: Output disabled.	0000

### 4.5.4 Recovered Clock Control

Register 23G in the extended register space controls the functionality of the recovered clock output signal.

**Table 75 • Recovered Clock Control, Address 23G (0x17)**

Bit	Name	Access	Description	Default
15	Enable RCVRD_CLK	R/W	1: Enable recovered clock output. 0: Disable recovered clock output.	0
14:11	Reserved	RO	Reserved.	
10:8	Clock frequency select	R/W	Select output clock frequency. 000: 25 MHz output clock. 001: 125 MHz output clock. 010: 31.25 MHz output clock. 011–111: Reserved.	000
7:6	Reserved	RO	Reserved.	
5:4	Clock squelch level	R/W	Select clock squelch level. 00: Automatically squelch clock to low when the link is not up, is unstable, is up in a mode that does not support the generation of a recovered clock (1000BASE-T master or 10BASE-T), or is up in EEE mode (100BASE-TX or 1000BASE-T slave). 01: Same as 00 except that the clock is also generated in 1000BASE-T master and 10BASE-T link-up modes. This mode also generates a recovered clock output in EEE mode during reception of LP_IDLE. 10: Squelch only when the link is not up. 11: Disable clock squelch. <b>Note:</b> A clock from the Cu PHY will be output on the recovered clock output in this mode when the link is down.	00
3	Reserved	RO	Reserved.	
2:0	Clock selection	R/W	000: Reserved. 001: Copper PHY recovered clock. 010–111: Reserved.	000

When the CLK\_SQUELCH\_IN pin is set high, it squelches the recovered clocks regardless of bit settings.

## 4.5.5 Enhanced LED Control

Register 25G in the extended register space controls the advanced functionality of the parallel LED signals.

**Table 76 • Enhanced LED Control, Address 25G (0x19)**

Bit	Name	Access	Description	Default
15:8	LED pulsing duty cycle control	R/W	Programmable control for LED pulsing duty cycle when bit 30.12 is set to 1. Valid settings are between 0 and 198. A setting of 0 corresponds to a 0.5% duty cycle and 198 corresponds to a 99.5% duty cycle. Intermediate values change the duty cycle in 0.5% increments.	0x00
7:0	Reserved	RO	Reserved.	

## 4.6 Clause 45 Registers to Support Energy-Efficient Ethernet and 802.3bf

This section describes the Clause 45 registers that are required to support energy-efficient Ethernet. Access to these registers is through the IEEE standard registers 13 and 14 (MMD access control and MMD data or address registers).

The following table lists the addresses and register names in the Clause 45 register page space. When the link is down, 0 is the value returned for the x.180x addresses.

**Table 77 • Clause 45 Registers Page Space**

Address	Name
1.1	PMA/PMD status 1
1.1800	PMA/PMD time sync capable
1.1801	PMA/PMD delay Tx max.
1.1803	PMA/PMD delay Tx min.
1.1805	PMA/PMD delay Rx max.
1.1807	PMA/PMD delay Rx min.
3.1	PCS status 1
3.20	EEE capability
3.22	EEE wake error counter
7.60	EEE advertisement
7.61	EEE link partner advertisement

### 4.6.1 PMA/PMD Status 1

The following table shows the bit descriptions for the PMA/PMD Status 1 register.

**Table 78 • PMA/PMD Status 1**

Bit	Name	Access	Description
15:3	Reserved	RO	Reserved.
2	PMD/PMA receive link status	RO/LL	1: PMA/PMD receive link up. 0: PMA/PMD receive link down.
1:0	Reserved	RO	Reserved.

## 4.6.2 PCS Status 1

The bits in the PCS Status 1 register provide a status of the EEE operation from the PCS for the link that is currently active.

**Table 79 • PCS Status 1, Address 3.1**

Bit	Name	Access	Description
15:12	Reserved	RO	Reserved.
11	Tx LPI received	RO/LH	1: Tx PCS has received LPI. 0: LPI not received.
10	Rx LPI received	RO/LH	1: Rx PCS has received LPI. 0: LPI not received.
9	Tx LPI indication	RO	1: Tx PCS is currently receiving LPI. 0: PCS is not currently receiving LPI.
8	Rx LPI indication	RO	1: Rx PCS is currently receiving LPI. 0: PCS is not currently receiving LPI.
7:3	Reserved	RO	Reserved.
2	PCS receive link status	RO/LL	1: PCS receive link up. 0: PCS receive link down.
1:0	Reserved	RO	Reserved.

## 4.6.3 EEE Capability

This register is used to indicate the capability of the PCS to support EEE functions for each PHY type. The following table shows the bit assignments for the EEE capability register.

**Table 80 • EEE Capability, Address 3.20**

Bit	Name	Access	Description
15:3	Reserved	RO	Reserved.
2	1000BASE-T EEE	RO	1: EEE is supported for 1000BASE-T. 0: EEE is not supported for 1000BASE-T.
1	100BASE-TX EEE	RO	1: EEE is supported for 100BASE-TX. 0: EEE is not supported for 100BASE-TX.
0	Reserved	RO	Reserved.

## 4.6.4 EEE Wake Error Counter

This register is used by PHY types that support EEE to count wake time faults where the PHY fails to complete its normal wake sequence within the time required for the specific PHY type. The definition of the fault event to be counted is defined for each PHY and can occur during a refresh or a wakeup as defined by the PHY. This 16-bit counter is reset to all zeros when the EEE wake error counter is read or when the PHY undergoes hardware or software reset.

**Table 81 • EEE Wake Error Counter, Address 3.22**

Bit	Name	Access	Description
15:0	Wake error counter	RO	Count of wake time faults for a PHY

## 4.6.5 EEE Advertisement

This register defines the EEE advertisement that is sent in the unformatted next page following a EEE technology message code. The following table shows the bit assignments for the EEE advertisement register.

**Table 82 • EEE Advertisement, Address 7.60**

Bit	Name	Access	Description	Default
15:3	Reserved	RO	Reserved.	
2	1000BASE-T EEE	R/W	1: Advertise that the 1000BASE-T has EEE capability. 0: Do not advertise that the 1000BASE-T has EEE capability.	0
1	100BASE-TX EEE	R/W	1: Advertise that the 100BASE-TX has EEE capability. 0: Do not advertise that the 100BASE-TX has EEE capability.	0
0	Reserved	RO	Reserved.	

## 4.6.6 EEE Link Partner Advertisement

All the bits in the EEE LP advertisement register are read only. A write to the EEE LP advertisement register has no effect. When the AN process has been completed, this register will reflect the contents of the link partner's EEE advertisement register. The following table shows the bit assignments for the EEE advertisement register.

**Table 83 • EEE Advertisement, Address 7.61**

Bit	Name	Access	Description
15:3	Reserved	RO	Reserved.
2	1000BASE-T EEE	RO	1: Link partner is advertising EEE capability for 1000BASE-T. 0: Link partner is not advertising EEE capability for 1000BASE-T.
1	100BASE-TX EEE	RO	1: Link partner is advertising EEE capability for 100BASE-TX. 0: Link partner is not advertising EEE capability for 100BASE-TX.
0	Reserved	RO	Reserved.

## 4.6.7 802.3bf Registers

The following table shows the bit assignments for the 802.3bf registers. When the link is down, 0 is the value returned. 1.1801 would be device address of 1 and register address of 1801.

**Table 84 • 802.3bf Registers**

Register	Name	Function
1.1800	PMA/PMD Time Sync capable	1: PMA/PMD Time Sync Tx capable. 0: PMA/PMD Time Sync Rx capable.
1.1801	PMA/PMD delay Tx max	Tx maximum delay through PHY (PMA/PMD/PCS).
1.1803	PMA/PMD delay Tx min	Tx minimum delay through PHY (PMA/PMD/PCS).
1.1805	PMA/PMD delay Rx max	Rx maximum delay through PHY (PMA/PMD/PCS).
1.1807	PMA/PMD delay Rx min	Rx minimum delay through PHY (PMA/PMD/PCS).

## 5 Electrical Specifications

This section provides the DC characteristics, AC characteristics, recommended operating conditions, and stress ratings for the VSC8541-01 device.

### 5.1 DC Characteristics

This section contains the DC specifications for the VSC8541-01 device.

#### 5.1.1 VDDMAC, VDDIO, and VDDMDIO (2.5 V)

The following table shows the DC specifications for the pins referenced to VDDMAC, VDDIO, and VDDMDIO when it is set to 2.5 V. The specifications listed in the following table are valid only when VDD1 = 1.0 V, VDD1A = 1.0 V, and VDD25A = 2.5 V.

**Table 85 • VDDMAC, VDDIO, and VDDMDIO (2.5 V) DC Characteristics**

Parameter	Symbol	Minimum	Typical	Maximum	Unit	Condition
Output high voltage	$V_{OH}$	2.0			V	$I_{OH} = -1.0$ mA
Output low voltage	$V_{OL}$			0.4	V	$I_{OL} = 1.0$ mA
Input high voltage	$V_{IH}$	1.85		3.6	V	
Input high voltage	$V_{IH}$	1.85		3.1	V	SMI pins (MDC, MDIO)
Input high voltage	$V_{IH}$	1.85		2.75	V	VDDMAC-referenced pins
Input low voltage	$V_{IL}$	-0.3		0.7	V	
Input leakage current	$I_{ILEAK}$	-85		85	$\mu$ A	Internal resistor included
Output leakage current	$I_{OLEAK}$	-85		85	$\mu$ A	Internal resistor included

#### 5.1.2 VDDMAC, VDDIO, and VDDMDIO (3.3 V)

The following table shows the DC specifications for the pins referenced to VDDMAC, VDDIO, and VDDMDIO when it is set to 3.3 V. The specifications listed in the following table are valid only when VDD1 = 1.0 V, VDD1A = 1.0 V, and VDD25A = 2.5 V.

**Table 86 • VDDMAC, VDDIO, and VDDMDIO (3.3 V) DC Characteristics**

Parameter	Symbol	Minimum	Typical	Maximum	Unit	Condition
Output high voltage	$V_{OH}$	2.6			V	$I_{OH} = -1.0$ mA
Output low voltage	$V_{OL}$			0.4	V	$I_{OL} = 1.0$ mA
Input high voltage	$V_{IH}$	2.25		3.6	V	
Input low voltage	$V_{IL}$	-0.3		0.8	V	
Input leakage current	$I_{ILEAK}$	-135		135	$\mu$ A	Internal resistor included
Output leakage current	$I_{OLEAK}$	-135		135	$\mu$ A	Internal resistor included

### 5.1.3 VDDMAC and VDDMDIO (1.5 V)

The following table shows the DC specifications for the pins referenced to VDDMAC and VDDMDIO when it is set to 1.5 V. The specifications listed in the following table are valid only when VDD1 = 1.0 V, VDD1A = 1.0 V, VDD25A = 2.5 V, and VDDIO = 2.5 V or 3.3 V.

**Table 87 • VDDMAC and VDDMDIO DC Characteristics (1.5 V)**

Parameter	Symbol	Minimum	Typical	Maximum	Unit	Condition
Output high voltage	$V_{OH}$	1.2			V	$I_{OH} = -1$ mA
Output low voltage	$V_{OL}$			0.25	V	$I_{OL} = 1$ mA
Input high voltage	$V_{IH}$	1.13		1.87	V	VDDMDIO-referenced pins
Input high voltage	$V_{IH}$	1.13		1.65	V	VDDMAC-referenced pins
Input low voltage	$V_{IL}$	-0.375		0.45	V	
Input leakage current	$I_{ILEAK}$	-40		40	$\mu$ A	Internal resistor included
Output leakage current	$I_{OLEAK}$	-40		40	$\mu$ A	Internal resistor included

### 5.1.4 VDDMAC and VDDMDIO (1.8 V)

The following table shows the DC specifications for the pins references to VDDMAC and VDDMDIO when it is set to 1.8 V. The specifications listed in the following table are valid only when VDD1 = 1.0 V, VDD1A = 1.0 V, VDD25A = 2.5 V, and VDDIO = 2.5 V or 3.3 V.

**Table 88 • VDDMAC and VDDMDIO DC Characteristics (1.8 V)**

Parameter	Symbol	Minimum	Typical	Maximum	Unit	Condition
Output high voltage	$V_{OH}$	1.43			V	$I_{OH} = -1$ mA
Output low voltage	$V_{OL}$			0.3	V	$I_{OL} = 1$ mA
Input high voltage	$V_{IH}$	1.35		2.25	V	VDDMDIO-referenced pins
Input high voltage	$V_{IH}$	1.35		1.98	V	VDDMAC-referenced pins
Input low voltage	$V_{IL}$	-0.45		0.54	V	
Input leakage current	$I_{ILEAK}$	-48		48	$\mu$ A	Internal resistor included
Output leakage current	$I_{OLEAK}$	-48		48	$\mu$ A	Internal resistor included

### 5.1.5 VDDMDIO (1.2 V)

The following table shows the DC specifications for the pins referenced to VDDMDIO when it is set to 1.2 V. The specifications listed in the following table are valid only when VDD1 = 1.0 V, VDD1A = 1.0 V, and VDD25A = 2.5 V.

**Table 89 • VDDMDIO DC Characteristics**

Parameter	Symbol	Minimum	Typical	Maximum	Unit	Condition
Output high voltage	$V_{OH}$	0.95			V	$I_{OH} = -1$ mA
Output low voltage	$V_{OL}$			0.2	V	$I_{OL} = 1$ mA
Input high voltage	$V_{IH}$	0.9		1.5	V	
Input low voltage	$V_{IL}$	-0.3		0.36	V	

**Table 89 • VDDMDIO DC Characteristics (continued)**

Parameter	Symbol	Minimum	Typical	Maximum	Unit	Condition
Input leakage current	$I_{ILEAK}$	-32		32	$\mu\text{A}$	Internal resistor included
Output leakage current	$I_{OLEAK}$	-32		32	$\mu\text{A}$	Internal resistor included

### 5.1.6 XTAL1

The following table shows the DC specifications for the XTAL1 pin referenced to VDD25A. The specifications listed in the following table are valid only when VDD1 = 1.0 V, VDD1A = 1.0 V, and the on-chip oscillator is turned off.

**Table 90 • XTAL1 DC Characteristics**

Parameter	Symbol	Minimum	Typical	Maximum	Unit
Input high voltage	$V_{IH}$	1.85		2.75	V
Input low voltage	$V_{IL}$	-0.3		0.7	V
Input leakage current	$I_{ILEAK}$	-85		85	$\mu\text{A}$
Output leakage current	$I_{OLEAK}$	-85		85	$\mu\text{A}$

### 5.1.7 LED

The following table shows the DC specifications for the LED pins.

**Table 91 • LED DC Characteristics**

Parameter	Symbol	Minimum	Typical	Maximum	Unit
Output high current drive strength	$I_{OH}$			-24	mA
Output low current drive strength	$I_{OL}$	24			mA

### 5.1.8 Internal Pull-Up or Pull-Down Resistors

Internal pull-up or pull-down resistors are specified in the following table. All internal pull-up resistors are connected to their respective I/O supply.

**Table 92 • Internal Pull-Up or Pull-Down Resistors (GMII/MII/RGMII/RMII Interface)**

Parameter	Symbol	Minimum	Typical	Maximum	Unit	Condition
Internal pull-down resistor	$R_{PD}$	31	46	72	$k\Omega$	3.3 V
Internal pull-down resistor	$R_{PD}$	38	59	96	$k\Omega$	2.5 V
Internal pull-down resistor	$R_{PD}$	57	91	155	$k\Omega$	1.8 V
Internal pull-down resistor	$R_{PD}$	78	125	220	$k\Omega$	1.5 V

**Table 93 • Internal Pull-Up or Pull-Down Resistors (Other I/Os)**

Parameter	Symbol	Minimum	Typical	Maximum	Unit	Condition
Internal pull-up resistor	$R_{PU}$	26	39	64	$k\Omega$	3.3 V
Internal pull-down resistor	$R_{PD}$	26	45	79	$k\Omega$	3.3 V
Internal pull-up resistor	$R_{PU}$	33	53	93	$k\Omega$	2.5 V
Internal pull-down resistor	$R_{PD}$	34	58	108	$k\Omega$	2.5 V

## 5.1.9 Current Consumption

The following table shows the measured current consumption values for each mode of operation. Add values from table for VDDMAC current consumption to calculate total typical current for each power supply. Add significant margin above the values for sizing power supplies.

**Note:** VDDMAC currents at 1.5 V and 1.8 V are measured with an edge rate setting of 111. Currents at 2.5 V and 3.3 V are measured with an edge rate setting of 100.

**Table 94 • Current Consumption**

Mode	Typical (mA)			
	VDD1	VDD1A	VDD25A	VDDIO/VDDMDIO
Reset	15	5	5	5
Power Down	20	20	15	5
ActiPHY	20	20	20	5
No Link	30	20	55	5
1000BASE-T	90	25	150	5
100BASE-TX	35	20	100	5
10BASE-T	20	20	65	5
1000BASE-T EEE	25	20	60	5
100BASE-TX EEE	25	20	60	5
10BASE-Te	20	20	60	5

**Table 95 • Current Consumption (VDDMAC)**

Mode	Typical (mA)			
	1.5 V	1.8 V	2.5 V	3.3 V
Reset	5	5	5	5
Power Down	10	10	15	20
ActiPHY	10	10	15	20
No Link	10	10	15	20
GMII (1000BASE-T)	30	40	55	75
MII (100BASE-TX)	10	10	15	15
MII (10BASE-T/Te)	5	5	5	5
RGMI (1000BASE-T)	25	30	45	65
RGMI (100BASE-TX)	5	10	10	15
RGMI (10BASE-T/Te)	5	5	5	5
RMII (100BASE-TX)	10	15	15	20
RMII (10BASE-T/Te)	10	10	15	15

**Table 96 • Power Consumption**

Parameter	Symbol	Typical	Maximum	Unit
Worst-case power consumption	P <sub>D</sub>		980	mW

## 5.1.10 Thermal Diode

The device includes an on-die diode and internal circuitry for monitoring die temperature (junction temperature). The operation and accuracy of the diode is not guaranteed and should only be used as a reference.

The on-die thermal diode requires an external thermal sensor, located on the board or in a stand-alone measurement kit. Temperature measurement using a thermal diode is very sensitive to noise. The following illustration shows a generic application design.

**Figure 23 • Thermal Diode**

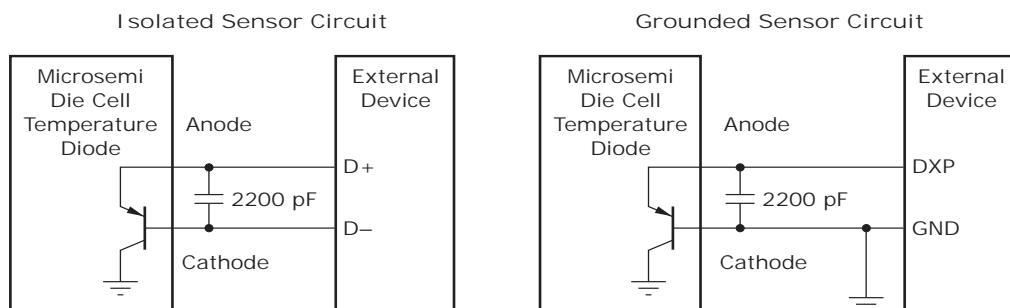

**Note:** Microsemi does not support or recommend operation of the thermal diode under reverse bias.

The following table provides the diode parameter and interface specifications with the pins connected internally to VSS in the device.

**Table 97 • Thermal Diode Parameters**

Parameter	Symbol	Typical	Maximum	Unit
Forward bias current	$I_{FW}$	See note <sup>1</sup>	1	mA
Diode ideality factor	$n$	1.008		

1. Typical value is device dependent.

The ideality factor,  $n$ , represents the deviation from ideal diode behavior as exemplified by the diode equation:

$$I_{FW} = I_S (e^{(qV_D)/(nkT)} - 1)$$

where,  $I_S$  = saturation current,  $q$  = electronic charge,  $V_D$  = voltage across the diode,  $k$  = Boltzmann constant, and  $T$  = absolute temperature (Kelvin).

## 5.2 AC Characteristics

This section provides the AC specifications for the VSC8541-01 device.

### 5.2.1 Reference Clock

The following table lists the AC specifications for the REFCLK reference clock.

**Table 98 • RefClk**

Parameter	Symbol	Minimum	Typical	Maximum	Unit	Condition
REFCLK frequency, REFCLK_SEL[1:0]= 11	$f$	-100 ppm	125	100 ppm	MHz	
REFCLK frequency, REFCLK_SEL[1:0]= 10	$f$	-100 ppm	50	100 ppm	MHz	

**Table 98 • RefClk (continued)**

Parameter	Symbol	Minimum	Typical	Maximum	Unit	Condition
REFCLK frequency, REFCLK_SEL[1:0]= 01	$f$	-100 ppm	25	100 ppm	MHz	
Rise time and fall time	$t_R, t_F$			1.5	ns	20% to 80%, 5.1 pF load
Duty cycle		45		55	%	
Phase jitter—Gaussian				4	ps <sub>RMS</sub>	Bandwidth from 10 kHz to 10 MHz
Total jitter, peak-to-peak				200	ps <sub>PP</sub>	10K samples.

### 5.2.1.1 XTAL Reference Clock

When using the 25 MHz crystal clock input option (REFCLK\_SEL[1:0] = 00), the additional specifications listed in the following table are required.

**Table 99 • XTAL RefClk**

Parameter	Symbol	Minimum	Typical	Maximum	Unit
CL <sup>1</sup>		8			pF
Crystal ESR				60	Ω

$$1. \quad CL = \frac{C1_{EXT} \times C2_{EXT}}{C1_{EXT} + C2_{EXT}}$$

where

$$C1_{EXT} = C1 + CIN_{EXT}$$

$$C2_{EXT} = C2 + COUT_{EXT}$$

CIN<sub>EXT</sub> represents input (XTAL1) I/O, bond pad, package pin, and routing parasitic capacitance

and COUT<sub>EXT</sub> represents output (XTAL2) I/O, bond pad, package pin, and routing parasitic capacitance.

For a reference tank circuit, see [Figure 10](#), page 14.

### 5.2.2 Recovered Clock

This section provides the AC characteristics for the recovered clock output signal. The following table shows the AC specifications for the RCVRD\_CLK output.

**Table 100 • Recovered Clock AC Characteristics**

Parameter	Symbol	Minimum	Typical	Maximum	Unit	Condition
Recovered clock frequency	$f$		125		MHz	
Recovered clock frequency	$f$		31.25		MHz	
Recovered clock frequency	$f$		25		MHz	
Recovered clock cycle time	$t_{RCYC}$		8		ns	
Recovered clock cycle time	$t_{RCYC}$		32		ns	
Recovered clock cycle time	$t_{RCYC}$		40		ns	
Frequency stability	$f_{STABILITY}$			50	ppm	
Duty cycle	DC	40	50	60	%	
Clock rise time and fall time	$t_R, t_F$			1.2	ns	20% to 80%

**Table 100 • Recovered Clock AC Characteristics (continued)**

Parameter	Symbol	Minimum	Typical	Maximum	Unit	Condition
Peak-to-peak jitter, copper media interface, 1000BASE-T, slave mode	$JPP_{CLK\_Cu}$			400	ps	10k samples.

The following illustration shows the test circuit for the CLKOUT, RCVRD\_CLK, and RMII\_CLKOUT outputs.

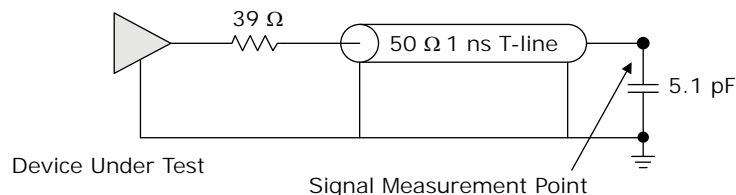
**Figure 24 • Test Circuit for Recovered Clock Outputs Signal**

### 5.2.3 CLKOUT

This section provides the AC characteristics for the CLKOUT signal.

The following table shows the AC specifications for the CLKOUT output.

**Table 101 • CLKOUT AC Characteristics**

Parameter	Symbol	Minimum	Typical	Maximum	Unit	Condition
CLKOUT frequency	$f$		125		MHz	
CLKOUT frequency	$f$		50		MHz	
CLKOUT frequency	$f$		25		MHz	
CLKOUT cycle time	$t_{COCYC}$		8		ns	
CLKOUT cycle time	$t_{COCYC}$		20		ns	
CLKOUT cycle time	$t_{COCYC}$		40		ns	
Frequency stability	$f_{STABILITY}$			5	ppm	Relative to device REFCLK frequency
Duty cycle	DC	40	50	60	%	CLKOUT at 25 MHz and 125 MHz
Duty cycle	DC	35	50	75	%	CLKOUT at 50 MHz
Clock rise time and fall time	$t_R, t_F$			1.5	ns	20% to 80%
Peak-to-peak jitter	$JPP_{CLKOUT}$			700	ps	10 k samples

### 5.2.4 RMII\_CLKOUT

This section provides the AC characteristics for the RMII\_CLKOUT signal.

**Note:** The RMII\_CLKOUT signal is provided on the RX\_CLK pin (see Table 3, page 6) when the device is operating in RMII mode.

The following table shows the AC specifications for RMII\_CLKOUT.

**Table 102 • RMII\_CLKOUT AC Characteristics**

Parameter	Symbol	Minimum	Typical	Maximum	Unit
RMII_CLKOUT frequency	$f$		50		MHz
RMII_CLKOUT duty cycle	DC	35		65	%

**Table 102 • RMII\_CLKOUT AC Characteristics (continued)**

Parameter	Symbol	Minimum	Typical	Maximum	Unit
RMII_CLKOUT rise time	$t_R$			1	ns
RMII_CLKOUT fall time	$t_F$			1	ns

## 5.2.5 Basic Serial LEDs

This section contains the AC specifications for the basic serial LEDs.

**Table 103 • Basic Serial LEDs AC Characteristics**

Parameter	Symbol	Typical	Unit
LED_CLK cycle time	$t_{CYC}$	1024	ns
Pause between LED port sequences	$t_{PAUSE\_PORT}$	3072	ns
Pause between LED bit sequences	$t_{PAUSE\_BIT}$	25.541632	ms
LED_CLK to LED_DATA	$t_{CO}$	1	ns

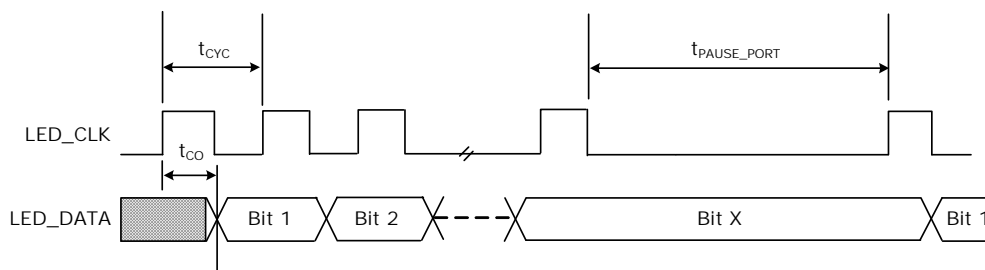
**Figure 25 • Basic Serial LED Timing**

## 5.2.6 RMII AC Characteristics

The following table lists the characteristics when using the device in RMII mode.

**Table 104 • RMII AC Characteristics**

Parameter	Symbol	Minimum	Typical	Maximum	Unit
TXD[1:0], TX_EN,RXD[1:0], CRS_DV, RX_ER data setup to RMII_CLKIN rising edge	$T_{SU}$	4			ns
TXD[1:0], TX_EN,RXD[1:0], CRS_DV, RX_ER data hold from RMII_CLKIN rising edge	$T_{HOLD}$	2			ns

## 5.2.7 GMII Transmit

The following table lists the characteristics when using the device in GMII transmit mode. For information about the GMII transmit timing, see [Figure 26](#), page 71.

**Table 105 • GMII Transmit AC Characteristics**

Parameter	Symbol	Minimum	Typical	Maximum	Unit	Condition
Clock frequency	$f_{CLK}$		125		MHz	
Frequency offset tolerance	$f_{TOL}$	-100		100	ppm	
Pulse width high	$t_{HIGH}$	2.5			ns	

**Table 105 • GMII Transmit (continued) AC Characteristics**

Parameter	Symbol	Minimum	Typical	Maximum	Unit	Condition
Pulse width low	$t_{LOW}$	2.5			ns	
Setup to GTX_CLK rising	$t_{SU}$	2.0			ns	
Hold from GTX_CLK rising	$t_H$	0			ns	When propagation delays of the GMII "clock" path is no more than 400 ps greater than the GMII "signal" path propagation delay.
GTX_CLK rise and fall times	$t_R$ and $t_F$			1.0	ns	Measured from 0.7 V to 1.9 V, $V_{DDMAC} = 2.5$ V and 3.3 V

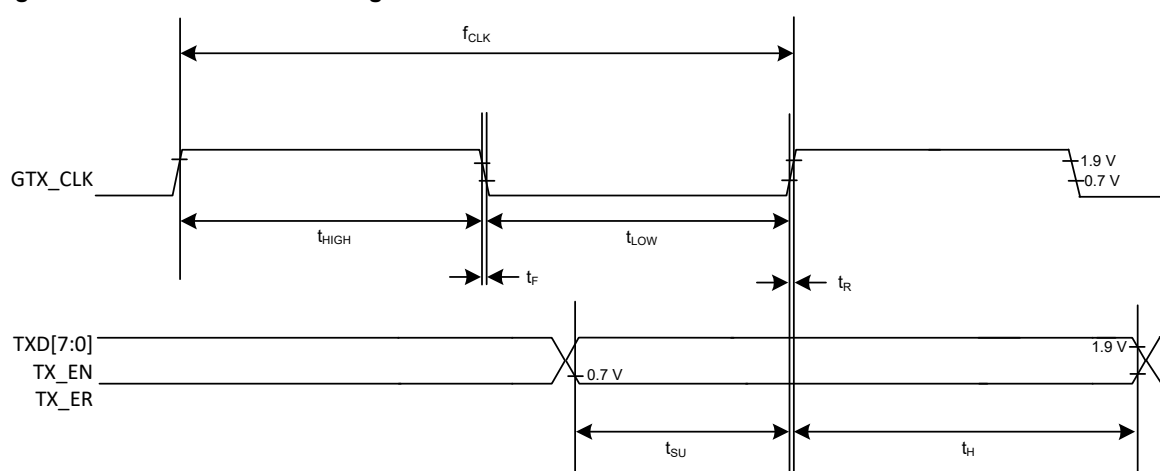
**Figure 26 • GMII Transmit Timing**

## 5.2.8 GMII Receive

The following table lists the characteristics when using the device in GMII receive mode. For information about the GMII receive timing, see [Figure 27](#), page 72.

**Table 106 • GMII Receive AC Characteristics**

Parameter	Symbol	Minimum	Typical	Maximum	Unit	Condition
Clock frequency	$f_{CLK}$		125		MHz	
Frequency offset tolerance	$f_{TOL}$	-100		100	ppm	
Pulse width high	$t_{HIGH}$	2.5			ns	
Pulse width low	$t_{LOW}$	2.5			ns	
Setup to RX_CLK rising	$t_{SU}$	2.5			ns	
Hold from RX_CLK rising	$t_H$	0.5			ns	
RX_CLK rise and fall times	$t_R$ and $t_F$			1.0	ns	Measured from 0.7 V to 1.9 V, $V_{DDMAC} = 2.5$ V and 3.3 V

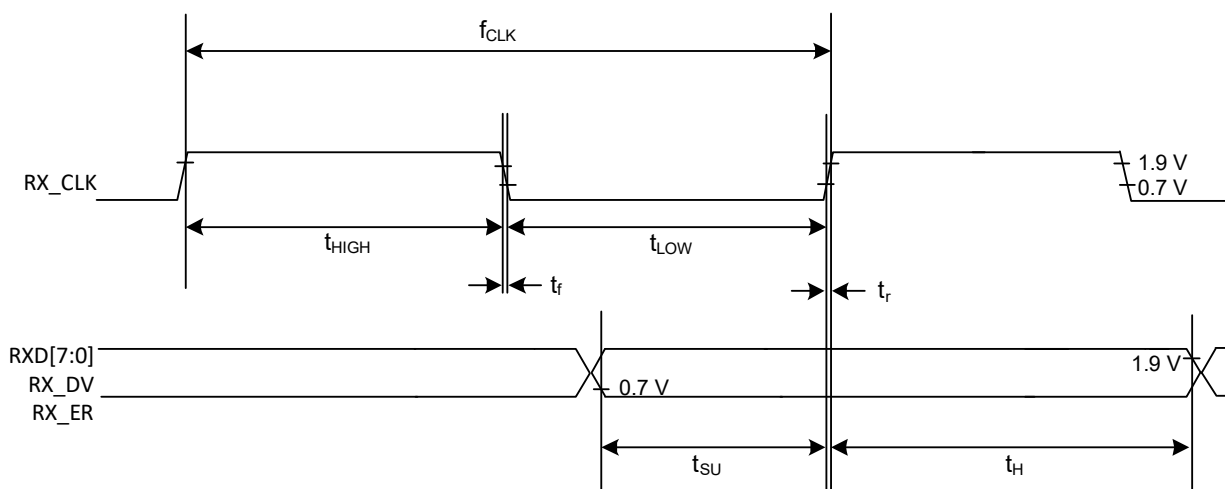
**Figure 27 • GMII Receive Timing**

## 5.2.9 MII Transmit

The following table lists the characteristics when using the device in MII transmit mode. For information about the MII transmit timing, see [Figure 28](#), page 72.

**Table 107 • MII Transmit AC Characteristics**

Parameter	Symbol	Minimum	Typical	Maximum	Unit
MII_TXCLK to TXD[3:0], TX_EN, TX_ER delay	$t_{\text{DELAY}}$	0		25	ns
MII_TXCLK duty cycle	DC	35		65	%

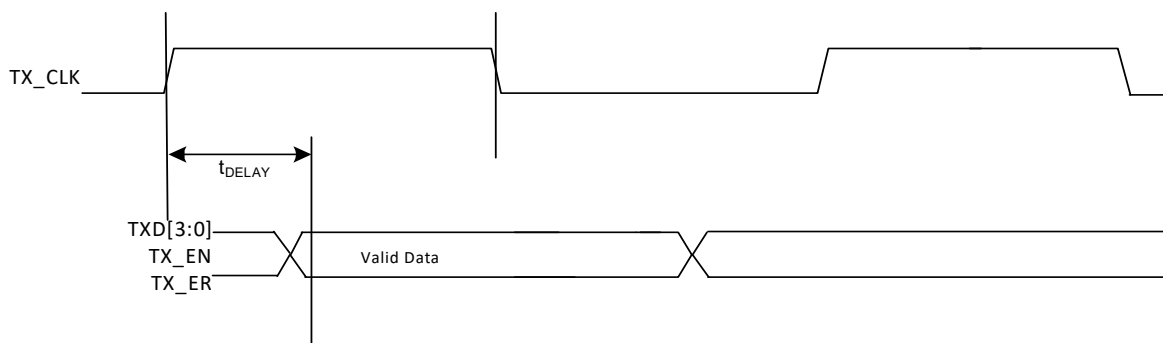
**Figure 28 • MII Transmit Timing**

## 5.2.10 MII Receive

The following table lists the characteristics when using the device in MII receive mode. For information about the MII receive timing, see [Figure 29](#), page 73.

**Table 108 • MII Receive AC Characteristics**

Parameter	Symbol	Minimum	Typical	Maximum	Unit	Condition
Setup to RX_CLK rising	$t_{\text{SU}}$	10			ns	
Hold from RX_CLK rising	$t_{\text{H}}$	10			ns	Measured from 0.8 V to 2.0 V, VDDMAC = 2.5 V and 3.3 V

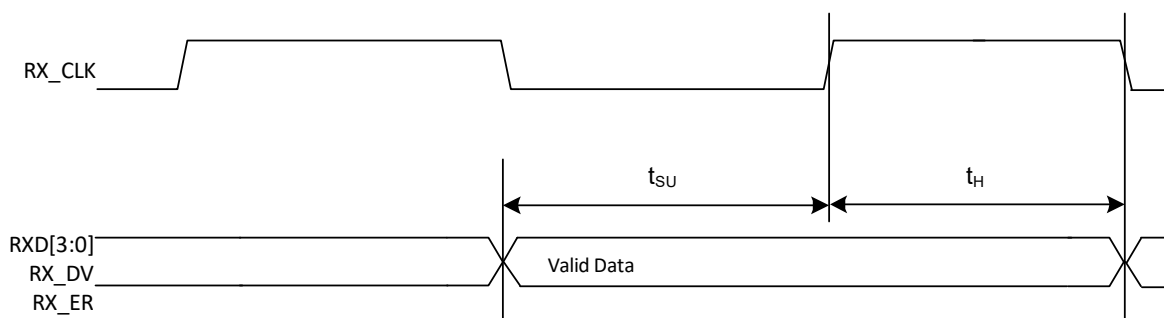
**Figure 29 • MII Receive Timing**

### 5.2.11 Uncompensated RGMII

The following table lists the characteristics when using the device in RGMII uncompensated mode. For more information about the RGMII uncompensated timing, see [Figure 30](#), page 74.

**Table 109 • Uncompensated RGMII AC Characteristics**

Parameter	Symbol	Minimum	Typical	Maximum	Unit	Condition
Clock frequency	$f_{CLK}$		125 25 2.5		MHz	1000BASE-T operation 100BASE-TX operation 10BASE-T operation
Duty cycle	DC	40	50	60	%	
Data to clock output skew (at Transmitter) <sup>1</sup>	$t_{SKEWT}$	-500		500	ps	
Data to clock output skew (at Receiver) <sup>1</sup>	$t_{SKEWR}$	1	1.8	2.6	ns	
TX_CLK switching threshold	$V_{THRESH}$		0.75 0.90 1.25 1.65		V	$V_{DDMAC} = 1.5\text{ V}$ $V_{DDMAC} = 1.8\text{ V}$ $V_{DDMAC} = 2.5\text{ V}$ $V_{DDMAC} = 3.3\text{ V}$
Clock/data output rise and fall times	$t_R, t_F$			0.75	ns	$V_{DDMAC} = 1.5\text{ V}$ , 27E2.7:5 = 111 $V_{DDMAC} = 1.8\text{ V}$ , 27E2.7:5 = 111 $V_{DDMAC} = 2.5\text{ V}$ , 27E2.7:5 = 100 $V_{DDMAC} = 3.3\text{ V}$ , 27E2.7:5 = 100

1. When operating in uncompensated mode, the PC board design requires a clock to be routed such that an additional trace delay of greater than 1.5 ns is added to the associated clock signal.

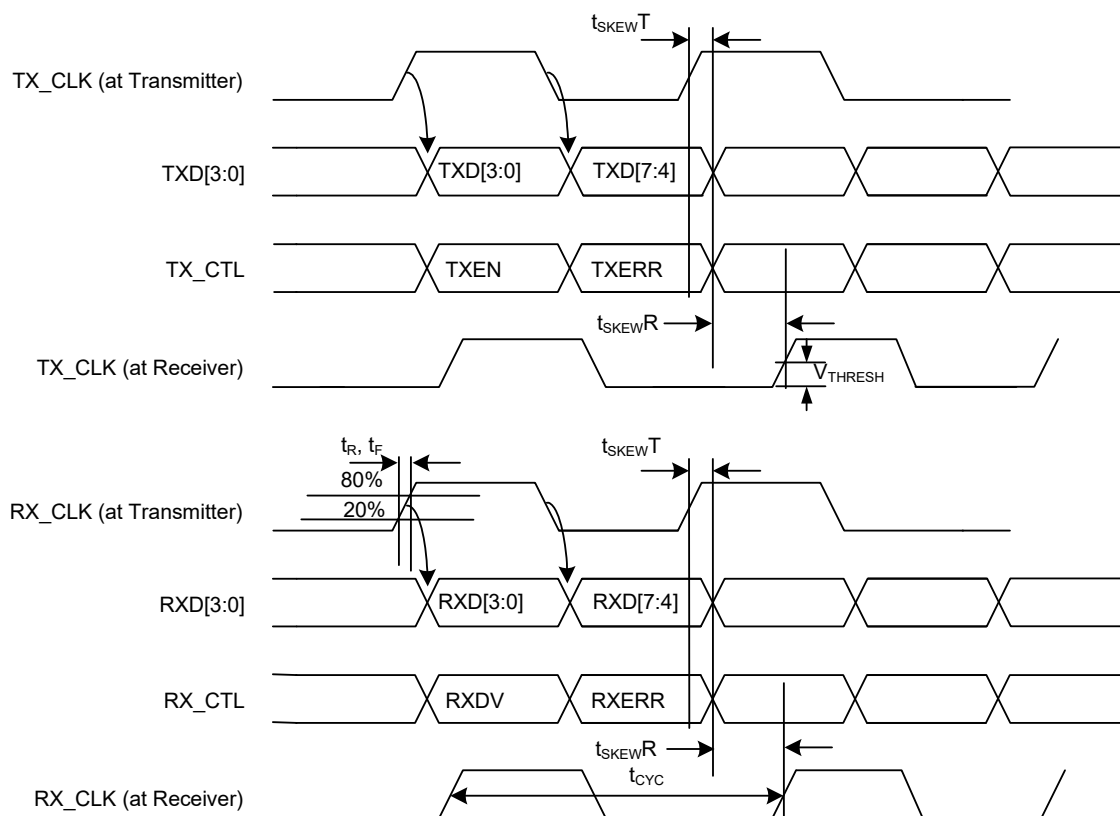
**Figure 30 • Uncompensated RGMII Timing**

### 5.2.12 Compensated RGMII

The following table lists the characteristics when using the device in RGMII compensated mode.

**Table 110 • PHY Input (GTX\_CLK Delay When Register 20E2.[2:0]=011'b)**

Parameter	Symbol	Minimum	Typical	Maximum	Unit
Data to clock setup (TX_CLK delay = 011'b)	$t_{\text{SETUP}_T}$	-1.0			ns
Clock to data hold (TX_CLK delay = 011'b)	$t_{\text{HOLD}_T}$	2.8			ns

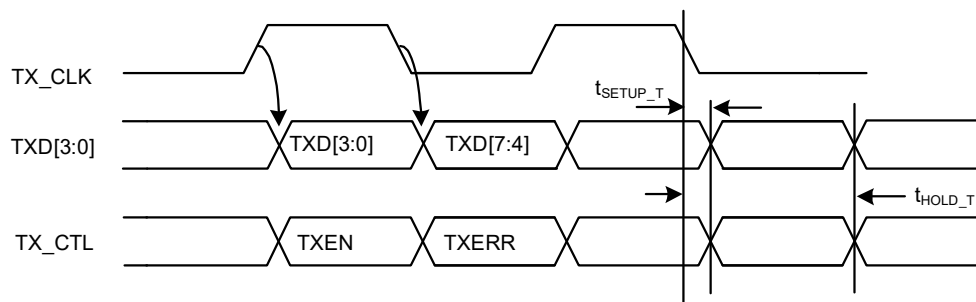
**Figure 31 • Compensated Input RGMII Timing****Table 111 • PHY Output (RX\_CLK Delay When Register 20E2.[6:4]=100'b)**

Parameter	Symbol	Minimum	Typical	Maximum	Unit
Data to clock setup (RX_CLK delay = 100'b)	$t_{\text{SETUP}_R}$	1.4	2.0		ns
Clock to data hold (RX_CLK delay = 100'b)	$t_{\text{HOLD}_R}$	1.5	2.0		ns

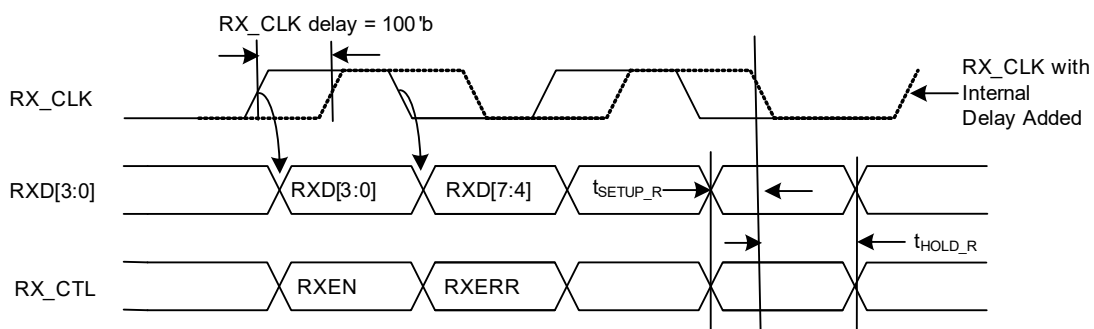
**Figure 32 • Compensated Output RGMII Timing**

## 5.2.13 Start of Frame Indication

This section contains the AC specifications for the SOF indication signals.

**Table 112 • Start of Frame Indication AC Characteristics**

Parameter	Symbol	Minimum	Typical	Maximum	Unit	Condition
TX_SOF_CLK/ RX_SOF_CLK frequency	$f_{\text{FREQ}}$	125 - 100 ppm	125	125 + 100 ppm	MHz	
TX_SOF_CLK/ RX_SOF_CLK stability	$f_{\text{STABILITY}}$			1.75	ppm	
TX_SOF_CLK/ RX_SOF_CLK duty cycle	DC	40		60	%	
TX_SOF_CLK/ RX_SOF_CLK peak-to-peak jitter	$JPP_{\text{CLK\_SOF}}$			350	ps	10 k samples
TX_SOF_CLK/ RX_SOF_CLK rise time	$t_R$			0.9	ns	20% to 80%
TX_SOF_CLK/ RX_SOF_CLK fall time	$t_F$			0.9	ns	20% to 80%

**Table 112 • Start of Frame Indication AC Characteristics (continued)**

Parameter	Symbol	Minimum	Typical	Maximum	Unit	Condition
Data to clock output skew (at PHY) RX_SOF_CLK to RX_SOF	$t_{\text{SKEW\_RX\_SOF}}$	700		1100	ps	
Data to clock output skew (at PHY) TX_SOF_CLK to TX_SOF	$t_{\text{SKEW\_TX\_SOF}}$	450		850	ps	

The following illustration shows the SOF indication timing.

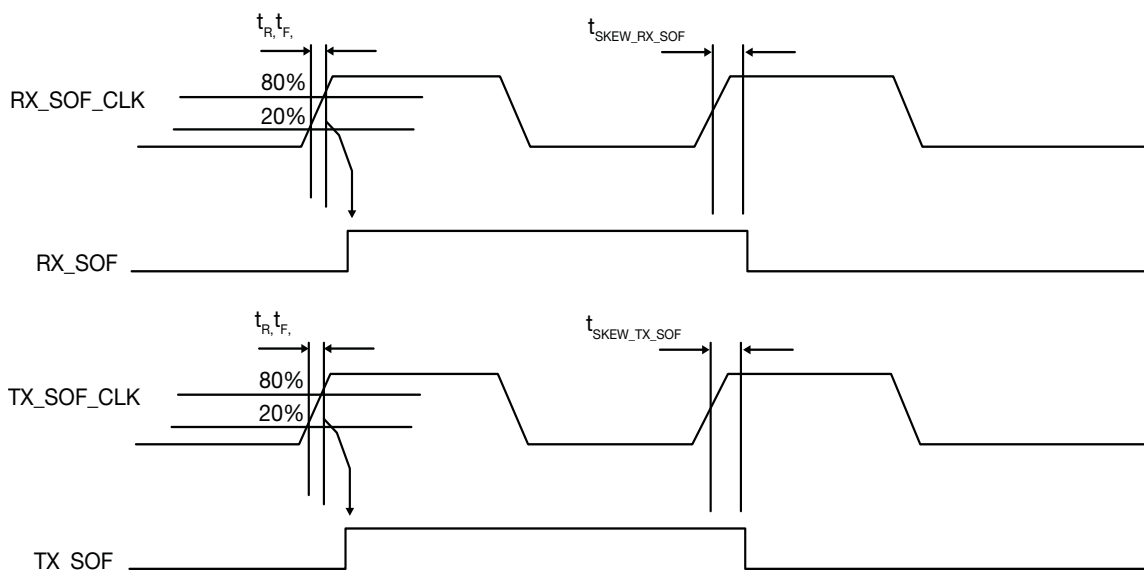
**Figure 33 • SOF Indication Timing**

## 5.2.14 Serial Management Interface

This section contains the AC specifications for the serial management interface (SMI).

**Table 113 • Serial Management Interface AC Characteristics**

Parameter	Symbol	Minimum	Typical	Maximum	Unit	Condition
MDC frequency <sup>1</sup>	$f_{\text{CLK}}$		2.5	12.5	MHz	
MDC cycle time	$t_{\text{CYC}}$	80	400		ns	
MDC time high	$t_{\text{WH}}$	20	50		ns	
MDC time low	$t_{\text{WL}}$	20	50		ns	
Setup to MDC rising	$t_{\text{SU}}$	10			ns	
Hold from MDC rising	$t_{\text{H}}$	14			ns	
MDC rise time	$t_{\text{R}}$			100 $t_{\text{CYC}} \times 10\%1$	ns	$f_{\text{CLK}} < 1$ MHz $f_{\text{CLK}}$ from 1 MHz to 12.5 MHz
MDC fall time	$t_{\text{F}}$			100 $t_{\text{CYC}} \times 10\%1$	ns	$f_{\text{CLK}} < 1$ MHz $f_{\text{CLK}}$ from 1 MHz to 12.5 MHz
MDC to MDIO valid	$t_{\text{CO}}$		10	300	ns	Time-dependent on the value of the external pull-up resistor on the MDIO pin

1. For  $f_{\text{CLK}}$  above 1 MHz, the maximum rise time and fall time is in relation to the frequency of the MDC clock period. For example, if  $f_{\text{CLK}}$  is 2 MHz, the maximum clock rise time and fall time is 50 ns.

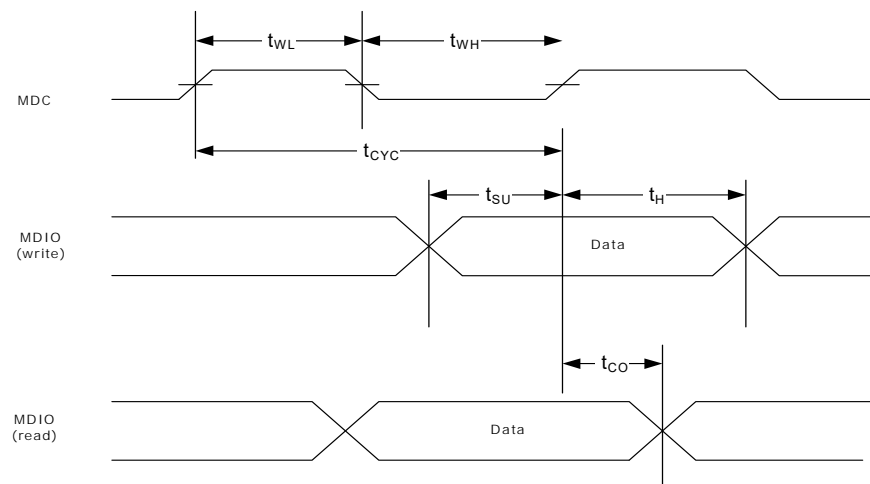
**Figure 34 • Serial Management Interface Timing**

## 5.2.15 Reset Timing

This section contains the AC specifications that apply to device reset functionality. The signal applied to the NRESET input must comply with the specifications listed in the following table.

**Table 114 • Reset Timing AC Characteristics**

Parameter	Symbol	Minimum	Typical	Maximum	Unit
NRESET assertion time after power supplies and clock stabilize	$t_W$	2			ms
Recovery time from reset inactive to device fully active	$t_{REC}$		15		ms
NRESET pulse width	$t_{W(RL)}$	100			ns
Wait time between NRESET de-assert and access of the SMI interface	$t_{WAIT}$	15			ms

## 5.3 Operating Conditions

The following table shows the recommended operating conditions for the VSC8541-01 device.

**Table 115 • Recommended Operating Conditions**

Parameter	Symbol	Minimum	Typical	Maximum	Unit
Power supply voltage for core supply	$V_{DD1}$	0.95	1.00	1.05	V
Power supply voltage for analog circuits	$V_{DD1A}$	0.95	1.00	1.05	V
2.5 V power supply voltage for analog circuits	$V_{DD25A}$	2.38	2.5	2.62	V
2.5 V power supply voltage for VDDMAC, VDDIO, and VDDMDIO	$V_{25}$	2.38	2.5	2.62	V
3.3 V power supply voltage for VDDMAC, VDDIO, and VDDMDIO	$V_{33}$	3.135	3.3	3.465	V
1.8 V power supply voltage for VDDMAC and VDDMDIO	$V_{18}$	1.71	1.8	1.89	V
1.5 V power supply voltage for VDDMAC and VDDMDIO	$V_{15}$	1.425	1.5	1.575	V
1.2 V power supply voltage for VDDMDIO	$V_{12}$	1.14	1.2	1.26	V
VSC8541-01 operating temperature <sup>1</sup>	T	0		125	°C
VSC8541-04 operating temperature <sup>1</sup>	T	-40		125	°C

1. Minimum specification is ambient temperature, and the maximum is junction temperature.

## 5.4 Stress Ratings

This section contains the stress ratings for the VSC8541-01 device.

**Warning** Stresses listed in the following table may be applied to devices one at a time without causing permanent damage. Functionality at or exceeding the values listed is not implied. Exposure to these values for extended periods may affect device reliability.

**Table 116 • Stress Ratings**

Parameter	Symbol	Minimum	Maximum	Unit
Power supply voltage for core supply	$V_{DD1}$	-0.3	1.10	V
Power supply voltage for analog circuits	$V_{DD1A}$	-0.3	1.10	V
Power supply voltage for analog circuits	$V_{DD25A}$	-0.3	2.75	V
Power supply voltage for digital I/O	$V_{DDMAC}$ , $V_{DDIO}$ , $V_{DDMDIO}$	-0.3	3.6	V
Input voltage for digital I/O (3.3 V)			3.6	V
Input voltage for digital I/O (2.5 V)			3.3	V
Storage temperature	$T_S$	-55	125	°C
Electrostatic discharge voltage, charged device model	$V_{ESD\_CDM}$	-1000	1000	V
Electrostatic discharge voltage, human body model	$V_{ESD\_HBM}$	See note <sup>1</sup>		V

1. This device has completed all required testing as specified in the JEDEC standard JESD22-A114, *Electrostatic Discharge (ESD) Sensitivity Testing Human Body Model (HBM)*, and complies with a Class 2 rating. The definition of Class 2 is any part that passes an ESD pulse of 2000 V, but fails an ESD pulse of 4000 V.

**Warning** This device can be damaged by electrostatic discharge (ESD) voltage. Microsemi recommends that all integrated circuits be handled with appropriate precautions. Failure to observe proper handling and installation procedures may adversely affect reliability of the device.

## 6 Pin Descriptions

The VSC8541-01 device has 68 pins, which are described in this section.



The pin information is also provided as an attached Microsoft Excel file so that you can copy it electronically. In Acrobat, double-click the attachment icon.

### 6.1 Pin Identifications

This section contains the pin descriptions for the VSC8541-01 device. The following table provides notations for definitions of the various pin types.

**Table 117 • Pin Type Symbol Definitions**

Symbol	Pin Type	Description
A	Analog	Analog.
ADIFF	Analog differential	Analog differential signal pair.
I	Input	Input without on-chip pull-up or pull-down resistor.
I/O	Bidirectional	Bidirectional input or output signal.
O	Output	Output signal.
P	Power	Power.
PD	Pull-down	On-chip pull-down resistor present.
PU	Pull-up	On-chip pull-up resistor present.

## 6.2 Pin Diagram

The following illustration shows the pin diagram for the VSC8541-01 device, as seen looking through the package from the top of it. Note that the exposed pad connects to the package ground.

Figure 35 • Pin Diagram

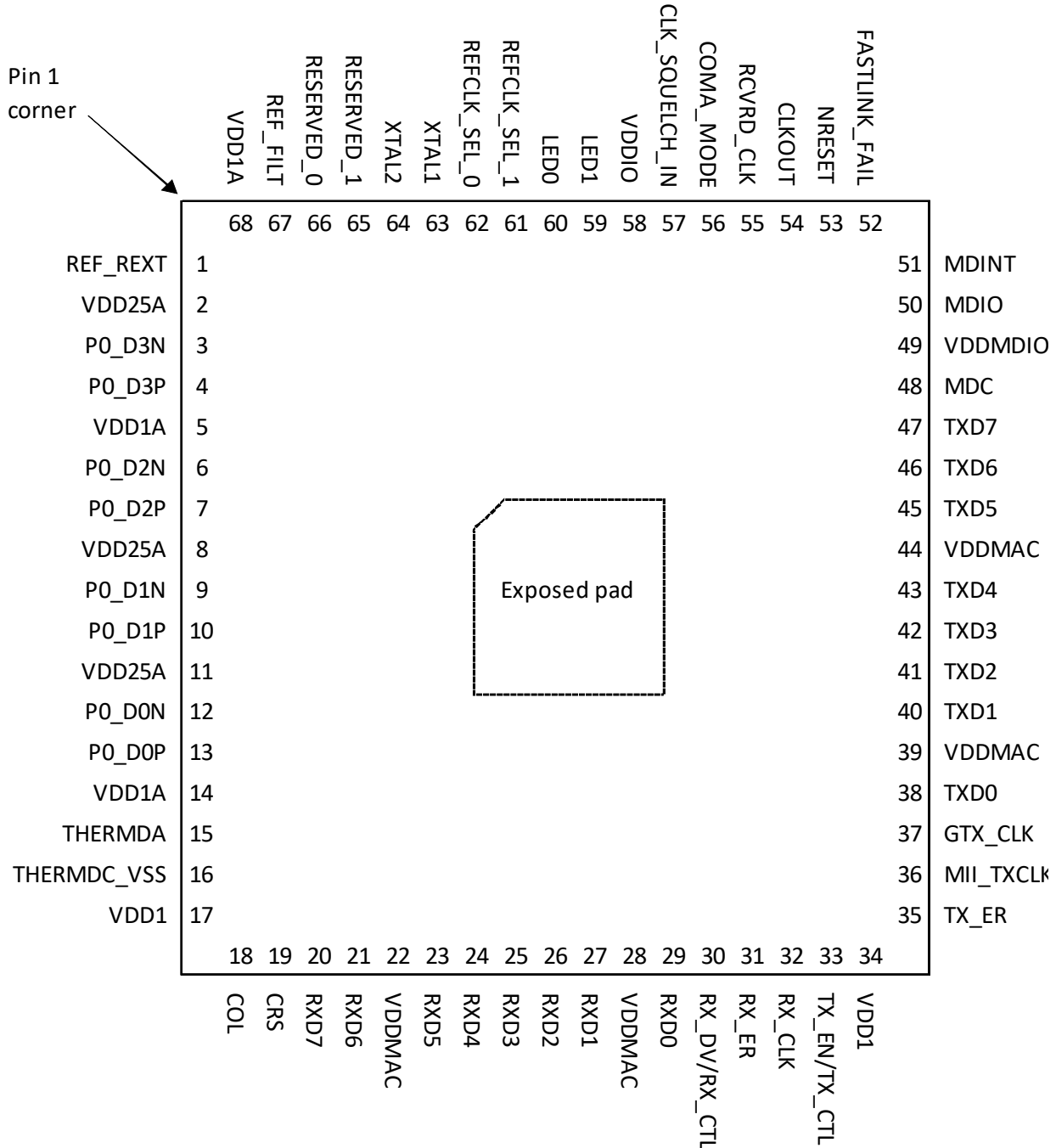

## 6.3 Pins by Function

This section contains the functional pin descriptions for the VSC8541-01 device. All power supply pins must be connected to their respective voltage input, even if certain functions are not used for a specific

application. No power supply sequencing is required. However, clock and power must be stable before releasing Reset. The SMI pins are referenced to VDDMDIO.

Functional Group	Name	Number	Type	I/O Domain	Description
Cu PHY Media	P0_D0N	12	ADIFF	VDD25A	Tx/Rx channel A negative signal
Cu PHY Media	P0_D0P	13	ADIFF	VDD25A	Tx/Rx channel A positive signal
Cu PHY Media	P0_D1N	9	ADIFF	VDD25A	Tx/Rx channel B negative signal
Cu PHY Media	P0_D1P	10	ADIFF	VDD25A	Tx/Rx channel B positive signal
Cu PHY Media	P0_D2N	6	ADIFF	VDD25A	Tx/Rx channel C negative signal
Cu PHY Media	P0_D2P	7	ADIFF	VDD25A	Tx/Rx channel C positive signal
Cu PHY Media	P0_D3N	3	ADIFF	VDD25A	Tx/Rx channel D negative signal
Cu PHY Media	P0_D3P	4	ADIFF	VDD25A	Tx/Rx channel D positive signal
Miscellaneous	REF_FILT	67	A	VDD25A	Reference filter connects to an external 0.01 uF (20%) capacitor to analog ground
Miscellaneous	REF_REXT	1	A	VDD25A	Reference connects to an external 2k $\Omega$ (1%) resistor to analog ground
Miscellaneous	RESERVED_0	66		VDD25A	Reserved signal, leave unconnected
Miscellaneous	RESERVED_1	65		VDD25A	Reserved signal, leave unconnected
Miscellaneous	THERMDA	15	A	VDD25A	Thermal Diode Anode
Miscellaneous	THERMDC_VSS	16	A	VDD25A	Thermal Diode Cathode connected to device ground. Temperature sensor must be chosen accordingly.
PHY Configuration	CLK_SQUELCH_IN	57	I, PD	VDDIO	Input control to squelch recovered clock
PHY Configuration	CLKOUT	54	I/O, PD	VDDIO	Clock output, can be enabled or disabled. Output a clock based on the local reference clock with programmable frequency. This pin is not active when NRESET is asserted and is disabled by default. When disabled, the pin is held low. The logic state on this pin is latched on the rising edge of NRESET to configure CLKOUT output. See "Hardware Mode Strapping and PHY Addressing" for details.
PHY Configuration	COMA_MODE	56	I/O, PU	VDDIO	When this pin is asserted high, PHY is held in a powered down state. When de-asserted low, PHY is powered up and resumes normal operation. This signal is also used to synchronize the operation of multiple chips on the same PCB to provide visual synchronization for LEDs driven by separate chips.
PHY Configuration	FASTLINK_FAIL	52	O	VDDIO	Fast link failure indication signal
PHY Configuration	LED0	60	O	VDDIO	LED direct drive outputs. All LED pins are active low. LED_DATA output in serial LED mode.
PHY Configuration	LED1	59	O	VDDIO	LED direct drive outputs. All LED pins are active low. LED_CLK output in serial LED mode.

PHY Configuration	NRESET	53	I, PD	VDDIO	Device reset. Active low input that powers down the device and sets all register bits to their default state.
PHY Configuration	RCVRD_CLK	55	O	VDDIO	Recovered clock output, can be enabled or disabled. Output a clock based on the selected active media with programmable frequency. This pin is not active when NRESET is asserted. When disabled, the pin is held low.
PHY Configuration	REFCLK_SEL_0	62	I, PU	VDDIO	Reference clock mode/frequency select signal
PHY Configuration	REFCLK_SEL_1	61	I, PU	VDDIO	Reference clock mode/frequency select signal
PHY Configuration	XTAL1	63	I	VDD25A	Crystal/single ended reference clock input
PHY Configuration	XTAL2	64	O	VDD25A	Crystal output, leave unconnected when using single ended reference clock
Power	VDD1	17	P		1.0 V digital core power
Power	VDD1	34	P		1.0 V digital core power
Power	VDD1A	5	P		1.0 V analog power requiring additional PCB power supply filtering
Power	VDD1A	14	P		1.0 V analog power requiring additional PCB power supply filtering
Power	VDD1A	68	P		1.0 V analog power requiring additional PCB power supply filtering
Power	VDD25A	2	P		2.5 V analog power requiring additional PCB power supply filtering
Power	VDD25A	8	P		2.5 V analog power requiring additional PCB power supply filtering
Power	VDD25A	11	P		2.5 V analog power requiring additional PCB power supply filtering
Power	VDDIO	58	P		2.5 V or 3.3 V general I/O power
Power	VDDMAC	22	P		1.5 V, 1.8 V, 2.5 V or 3.3 V GMII/MII/RGMII/RMII MAC power
Power	VDDMAC	28	P		1.5 V, 1.8 V, 2.5 V or 3.3 V GMII/MII/RGMII/RMII MAC power
Power	VDDMAC	39	P		1.5 V, 1.8 V, 2.5 V or 3.3 V GMII/MII/RGMII/RMII MAC power
Power	VDDMAC	44	P		1.5 V, 1.8 V, 2.5 V or 3.3 V GMII/MII/RGMII/RMII MAC power
Power	VDDMDIO	49	P		1.2 V, 1.5 V, 1.8 V, 2.5 V or 3.3 V power for SMI pins
R/GMII	COL	18	I/O, PD	VDDMAC	GMII/MII collision output. The logic state on this pin is latched on the rising edge of NRESET to configure the device. See "Hardware Mode Strapping and PHY Addressing" for details.
R/GMII	CRS	19	I/O, PD	VDDMAC	GMII/MII carrier sense output. The logic state on this pin is latched on the rising edge of NRESET to configure the device. See "Hardware Mode Strapping and PHY Addressing" for details.
R/GMII	GTX_CLK	37	I, PD	VDDMAC	GMII/RGMII transmit clock input

R/GMII	MII_TXCLK	36	I/O, PD	VDDMAC	MII transmit clock output. The logic state on this pin is latched on the rising edge of NRESET to configure the device. See "Hardware Mode Strapping and PHY Addressing" for details.
R/GMII	RX_CLK	32	I/O, PD	VDDMAC	GMII/MII receive clock output. The logic state on this pin is latched on the rising edge of NRESET to configure the device. See "Hardware Mode Strapping and PHY Addressing" for details.
R/GMII	RX_DV/RX_CTL	30	I/O, PD	VDDMAC	GMII/MII receive data valid output/RGMII receive control output. The logic state on this pin is latched on the rising edge of NRESET to configure the device. See "Hardware Mode Strapping and PHY Addressing" for details.
R/GMII	RX_ER	31	I/O, PD	VDDMAC	GMII/MII receive data error output. The logic state on this pin is latched on the rising edge of NRESET to configure the device. See "Hardware Mode Strapping and PHY Addressing" for details.
R/GMII	RXD0	29	I/O, PD	VDDMAC	GMII/MII/RGMII data output. The logic state on this pin is latched on the rising edge of NRESET to configure the device. See "Hardware Mode Strapping and PHY Addressing" for details.
R/GMII	RXD1	27	I/O, PD	VDDMAC	GMII/MII/RGMII data output. The logic state on this pin is latched on the rising edge of NRESET to configure the device. See "Hardware Mode Strapping and PHY Addressing" for details.
R/GMII	RXD2	26	I/O, PD	VDDMAC	GMII/MII/RGMII data output. The logic state on this pin is latched on the rising edge of NRESET to configure the device. See "Hardware Mode Strapping and PHY Addressing" for details.
R/GMII	RXD3	25	I/O, PD	VDDMAC	GMII/MII/RGMII data output. The logic state on this pin is latched on the rising edge of NRESET to configure the device. See "Hardware Mode Strapping and PHY Addressing" for details.
R/GMII	RXD4	24	I/O, PD	VDDMAC	GMII data output. The logic state on this pin is latched on the rising edge of NRESET to configure the device. See "Hardware Mode Strapping and PHY Addressing" for details.
R/GMII	RXD5	23	I/O, PD	VDDMAC	GMII data output. The logic state on this pin is latched on the rising edge of NRESET to configure the device. See "Hardware Mode Strapping and PHY Addressing" for details.

R/GMII	RXD6	21	I/O, PD	VDDMAC	GMII data output. The logic state on this pin is latched on the rising edge of NRESET to configure the device. See "Hardware Mode Strapping and PHY Addressing" for details.
R/GMII	RXD7	20	I/O, PD	VDDMAC	GMII data output. The logic state on this pin is latched on the rising edge of NRESET to configure the device. See "Hardware Mode Strapping and PHY Addressing" for details.
R/GMII	TX_EN/TX_CTL	33	I, PD	VDDMAC	GMII/MII transmit data enable input/RGMII transmit data control input
R/GMII	TX_ER	35	I, PD	VDDMAC	GMII/MII transmit data error input
R/GMII	TXD0	38	I, PD	VDDMAC	GMII/MII/RGMII data input
R/GMII	TXD1	40	I, PD	VDDMAC	GMII/MII/RGMII data input
R/GMII	TXD2	41	I, PD	VDDMAC	GMII/MII/RGMII data input
R/GMII	TXD3	42	I, PD	VDDMAC	GMII/MII/RGMII data input
R/GMII	TXD4	43	I, PD	VDDMAC	GMII data input
R/GMII	TXD5	45	I, PD	VDDMAC	GMII data input
R/GMII	TXD6	46	I, PD	VDDMAC	GMII data input
R/GMII	TXD7	47	I, PD	VDDMAC	GMII data input
SMI	MDC	48	I	VDDMDIO	Management data clock. A 0 MHz to 12.5 MHz reference input is used to clock serial MDIO data into and out of the PHY.
SMI	MDINT	51	O, OD	VDDMDIO	Management interrupt signal. These pins can be tied together in a wired-OR configuration with only a single pull-up resistor.
SMI	MDIO	50	I/O	VDDMDIO	Management data input/output pin. Serial data is written or read from this pin bi-directionally between the PHY and station manager synchronously on the positive edge of MDC. One external pull-up resistor is required at the station manager.

## 7 Package Information

---

The VSC8541XMV-01 package is a lead-free (Pb-free), 68-pin, plastic quad flat no-lead (QFN) package with an exposed pad, 8 mm × 8 mm body size, 0.4 mm pin pitch, and 0.9 mm maximum height.

Lead-free products from Microsemi comply with the temperatures and profiles defined in the joint IPC and JEDEC standard IPC/JEDEC J-STD-020. For more information, see the IPC and JEDEC standard.

This section provides the package drawing, thermal specifications, and moisture sensitivity rating for the VSC8541-01 device.

### 7.1 Package Drawing

The following illustration shows the package drawing for the VSC8541-01 device. The drawing contains the top view, bottom view, side view, dimensions, tolerances, and notes.

Figure 36 • Package Drawing

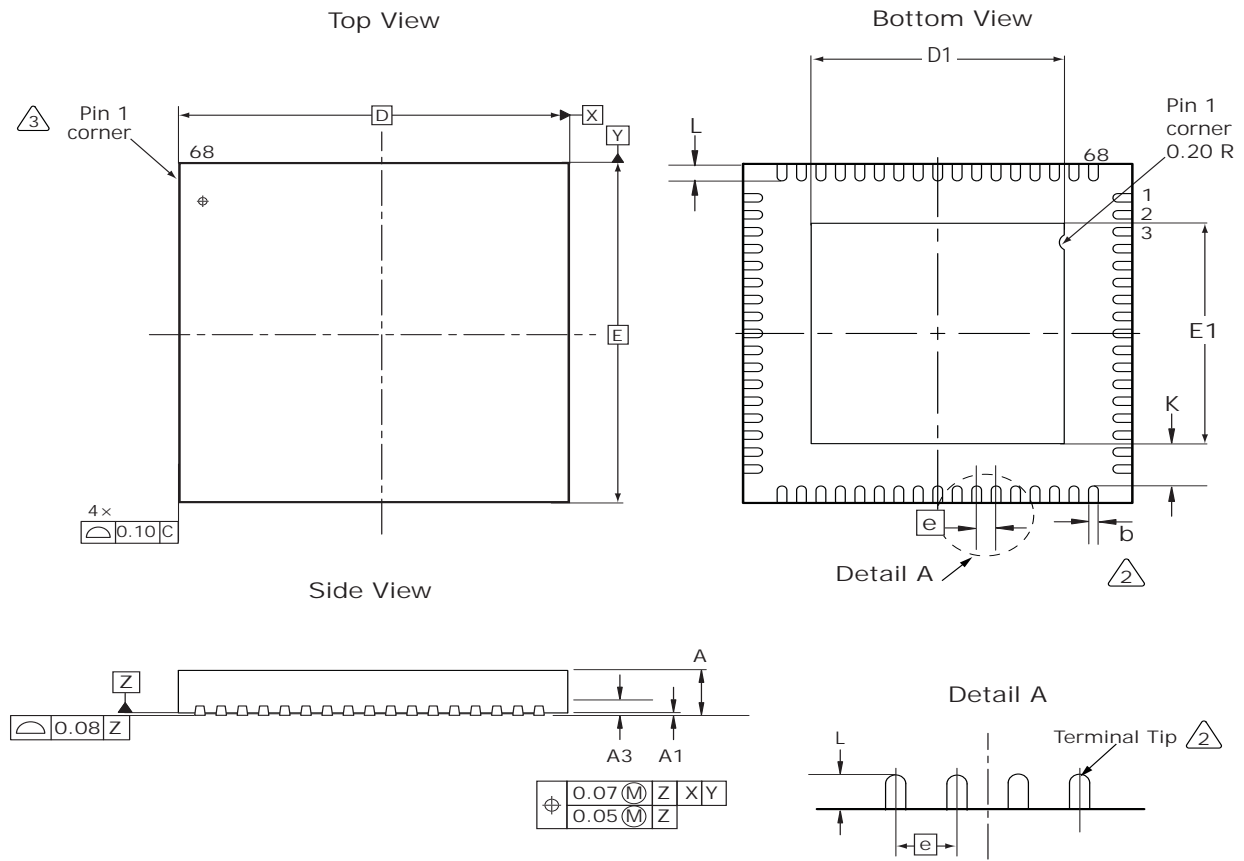

Notes

1. All dimensions and tolerances are in millimeters (mm).
2. Dimension b applies to the metallized terminal and is measured between 0.15 mm and 0.30 mm from the terminal tip.
3. Maximum package warpage is 0.08 mm.

Dimensions and Tolerances

Reference	Minimum	Nominal	Maximum
A	0.80	0.85	0.90
A1	0.00	0.02	0.05
A3		0.203 Ref	
D		8.00 BSC	
D1	5.10	5.20	5.30
E		8.00 BSC	
E1	5.10	5.20	5.30
K		1.00 Ref	
e		0.40 BSC	
L	0.30	0.40	0.50
b	0.15	0.20	0.25

## 7.2 Thermal Specifications

Thermal specifications for this device are based on the JEDEC JESD51 family of documents. These documents are available on the JEDEC website at [www.jedec.org](http://www.jedec.org). The thermal specifications are modeled using a four-layer test board with two signal layers, a power plane, and a ground plane (2s2p).

PCB). For more information about the thermal measurement method used for this device, see the JESD51-1 standard.

**Table 118 • Thermal Resistances**

Symbol	°C/W	Parameter
$\theta_{J\text{Ctop}}$	19.3	Die junction to package case top
$\theta_{JB}$	6.6	Die junction to printed circuit board
$\theta_{JA}$	26.6	Die junction to ambient
$\theta_{JMA}$ at 1 m/s	20.0	Die junction to moving air measured at an air speed of 1 m/s
$\theta_{JMA}$ at 2 m/s	19.0	Die junction to moving air measured at an air speed of 2 m/s

To achieve results similar to the modeled thermal measurements, the guidelines for board design described in the JESD51 family of publications must be applied. For information about applications using QFN packages, see the following:

- JESD51-2A, *Integrated Circuits Thermal Test Method Environmental Conditions, Natural Convection (Still Air)*
- JESD51-6, *Integrated Circuit Thermal Test Method Environmental Conditions, Forced Convection (Moving Air)*
- JESD51-8, *Integrated Circuit Thermal Test Method Environmental Conditions, Junction-to-Board*
- JESD51-7, *High Effective Thermal Conductivity Test Board for Leaded Surface Mount Packages*
- JESD51-5, *Extension of Thermal Test Board Standards for Packages with Direct Thermal Attachment Mechanisms*

## 7.3 Moisture Sensitivity

This device is rated moisture sensitivity level 3 or better as specified in the joint IPC and JEDEC standard IPC/JEDEC J-STD-020. For more information, see the IPC and JEDEC standard.

## 8 Design Considerations

---

This section provides information about design considerations for the VSC8541-01 device.

### 8.1 Link status LED remains on while COMA\_MODE pin is asserted high

When the COMA\_MODE is asserted high, the link status LED may not deactivate unless the media cable is disconnected from the device.

While using COMA\_MODE, link status should be verified using status registers rather than LED indicators.

### 8.2 Forced 1000BASE-T mode blocks some SMI register writes

When hardware strapping pins are used to force 1000BASE-T mode (as described in [Forced 1000BASE-T Mode](#), page 11), register writes to some serial management interface (SMI) registers are not allowed.

As a workaround for this issue when using hardware strapping pins to force 1000BASE-T mode, execute the following register writes before performing any other SMI register writes to the device.

1. Write 0x0000 to register address 31.
2. Read register address 9.
3. Modify read back value and set bits 15:13 to 0.
4. Write updated value to register address 9.

After performing steps 1–4, all SMI register writes behave normally.

### 8.3 Forced 1000BASE-T mode incorrectly reports interrupt status and PCS status counters

When operating in Forced 1000BASE-T mode, the device does not report interrupt status correctly within the interrupt status register (see [Interrupt Status](#), page 42). In addition, the device does not correctly report 1000BASE-T Status Extension 2 (see [1000BASE-T Status Extension 2](#), page 37) or error counts (see [Error Counter 1](#), page 38, [Error Counter 2](#), page 39, and [Error Counter 3](#), page 39).

Contact Microsemi for more information.

### 8.4 10BASE-T signal amplitude

10BASE-T signal amplitude can be lower than the minimum specified in IEEE 802.3 paragraph 14.3.1.2.1 (2.2 V) at low supply voltages. Additionally, associated templates may be marginal or have failures.

This issue is not estimated to present any system-level impact. Performance is not impaired with cables up to 130 m with various link partners.

### 8.5 Receive error counter only clears when NRESET applied in RMII mode

When operating in RMII MAC interface mode, the receive error counter of register 19 ([Table 38](#), page 38) does not clear upon read-back or software reset of the device. The only way to clear this register while in RMII mode is to assert the NRESET pin of the device.

The receive error counter at register address 19 operates normally in MAC interface modes other than RMII.

## 8.6 Anomalous PCS error indications in Energy Efficient Ethernet mode

When a port is processing traffic with EEE enabled on the link, certain PCS errors (such as false carriers, spurious start-of-stream detection, and idle errors) and EEE wake errors may occur. There is no effect on traffic bit error rate for cable lengths up to 75 meters, and minor packet loss may occur on links longer than 75 meters.

Regardless of cable length, some error indications should not be used while EEE is enabled. These error indications include false carrier interrupts ([Interrupt Status](#), page 42, bit 3), receive error interrupts ([Interrupt Status](#), page 42, bit 0), and EEE wake error interrupts.

Contact Microsemi for a script that needs to be applied during system initialization if EEE will be enabled.

## 8.7 10BASE-T half-duplex linkup after initial reset from power up

After initial power up, register 0 (Mode Control) may contain all zeros and thus operate in forced 10BASE-T half-duplex mode.

For applications with register access to the device, the workaround is to perform a software reset using register 0, bit 15 to restore the power-on default values. For more information, see [Mode Control](#), page 31.

For unmanaged applications without register access to the device, see the reset step in [Configuration](#), page 27.

## 8.8 RGMII interface may not generate even count of preamble nibbles at 10 Mbps

When operating in 10 Mbps mode, the PHY may generate either an even or an odd number of preamble nibbles. Certain third-party RGMII MAC hosts cannot process odd numbers of preamble nibbles, and will drop those odd-count frames. The nibble count output from the PHY is random, depending on input copper signal characteristics.

There is no workaround for those MAC hosts that lack odd-or-even alignment capability for RGMII data streams received at their input pins.

## 8.9 Long link up times while in forced 100BASE-TX mode

While in forced 100BASE-TX operation mode and attempting to link up, the device may experience abnormally long link-up times.

The workaround for this issue is to clear all speed advertisements in the autonegotiation advertisement registers (register 4, bits 9:5 and register 9, bits 9:8), then toggle the auto-negotiation enable bit of the mode control register (register 0, bit 12) for a port upon detecting repeated 100BASE-TX link-up attempts. Any advertisements temporarily cleared can then be restored once register 0, bit 12 is cleared.

Please contact Microsemi for the latest software to address this issue.

## 8.10 Long link up times for 100BASE-TX parallel detection

While parallel-detecting 100BASE-TX link partners and attempting to link up, the device may experience abnormally long link-up times.

The workaround for this issue is to restart media interface auto-negotiation using register 0, bit 9 for a port upon detecting repeated 100BASE-TX link-up attempts.

Please contact Microsemi for the latest software to address this issue.

## 9 Ordering Information

The VSC8541-01 device is offered with two operating temperature ranges. The range for VSC8541XMV-01 is 0 °C ambient to 125 °C junction. The range for VSC8541XMV-04 is –40 °C ambient to 125 °C junction.

The VSC8541XMV-01 package is a lead-free (Pb-free), 68-pin, plastic quad flat no-lead (QFN) package with an exposed pad, 8 mm × 8 mm body size, 0.4 mm pin pitch, and 0.9 mm maximum height.

Lead-free products from Microsemi comply with the temperatures and profiles defined in the joint IPC and JEDEC standard IPC/JEDEC J-STD-020. For more information, see the IPC and JEDEC standard.

The following table lists the ordering information for the VSC8541-01 device.

**Table 119 • Ordering Information**

Part Order Number	Description
VSC8541XMV-01	Lead-free, 68-pin, plastic QFN package with an exposed pad, 8 mm × 8 mm body size, 0.4 mm pin pitch, and 0.9 mm maximum height. The operating temperature is 0 °C ambient to 125 °C junction.
VSC8541XMV-04	Lead-free, 68-pin, plastic QFN package with an exposed pad, 8 mm × 8 mm body size, 0.4 mm pin pitch, and 0.9 mm maximum height. The operating temperature is –40 °C ambient to 125 °C junction.