

Product Overview

900 V, 46 A Power MOS 8 punch-through (PT) IGBT with co-packaged anti-parallel SiC diode, SOT-227

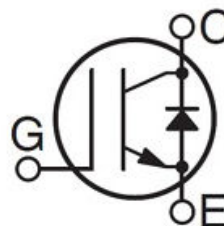
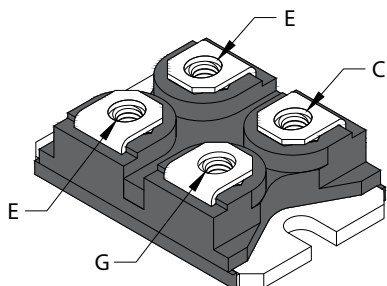

G—Gate
C—Collector, Diode Cathode
E—Emitter, Diode Anode

Table 1. Ordering Information

Catalog Part Number (CPN)	Package	Packing Media	Qualification
APT46GA90JSC30	SOT-227	Tube	Industrial

Features

- Low conduction loss and saturation voltage
- Low gate charge
- Ultrafast tail current shutoff
- No reverse recovery
- High operating frequency
- Switching safe operating area (SSOA) rated
- RoHS compliant
- Isolated voltage to 2500 V, UL certified file E145592 
- Zero E_{on} switching loss from co-packaged, anti-parallel diode

1. Device Specifications: IGBT

This section shows the specifications of this device.

1.1 Absolute Maximum Ratings

The following table shows the absolute maximum ratings of this device. $T_C = 25\text{ }^\circ\text{C}$ unless otherwise specified.

Table 1-1. Absolute Maximum Ratings

Symbol	Parameter	Ratings	Unit
V_{CES}	Collector-emitter voltage	900	V
V_{GE}	Gate-emitter voltage	± 30	
I_{C1}	Continuous collector current ($T_C = 25\text{ }^\circ\text{C}$)	87	A
I_{C2}	Continuous collector current ($T_C = 110\text{ }^\circ\text{C}$)	46	
I_{CM}	Pulsed collector current ¹ ($T_C = 150\text{ }^\circ\text{C}$)	136	
SSOA	Switching safe operating area ($T_J = 150\text{ }^\circ\text{C}$, 900 V)	136	
P_{TOT}	Total power dissipation	284	W

Note:

1. Repetitive rating: Pulse width and case temperature limited by the maximum junction temperature.

1.2 Thermal and Mechanical Characteristics

The following table shows the thermal and mechanical characteristics of this device.

Table 1-2. Thermal and Mechanical Characteristics

Symbol	Characteristic	Min.	Typ.	Max.	Unit
$R_{\theta JC}$	Junction-to-case thermal resistance (IGBT)			0.44	$^\circ\text{C}/\text{W}$
$R_{\theta JC}$	Junction-to-case thermal resistance (diode)			0.87	
T_J, T_{STG}	Operating and storage junction temperature range	-55		150	$^\circ\text{C}$
$V_{ISOLATION}$	RMS voltage (50 Hz–60 Hz sinusoidal waveform from terminals to mounting base for 1 minute)	2500			V
τ_M	Mounting torque, M3 screw for heat sink attachment (requires 2, not included)		0.8		N·m
τ_T	Terminal screw torque, M4 screw (4 included)			1.1	
Wt	Package weight		29.2		g

ESD practices should comply with JESD-625.

1.3 Electrical Performance

The following table shows the static characteristics of this device. $T_C = 25\text{ }^\circ\text{C}$ unless otherwise specified.

Table 1-3. Static Characteristics

Symbol	Characteristic	Test Conditions	Min.	Typ.	Max.	Unit
$V_{(BR)CES}$	Collector-emitter breakdown voltage	$V_{GE} = 0\text{ V}, I_C = 1.0\text{ mA}$	900			V
$V_{GE(th)}$	Gate threshold voltage	$V_{CE} = V_{GE}, I_C = 1.0\text{ mA}$	3	4.5	6	
$V_{CE(ON)}$	Collector-emitter on voltage	$V_{GE} = 15\text{ V}, I_C = 47\text{ A}$		2.5	3.1	
		$V_{GE} = 15\text{ V}, I_C = 47\text{ A}, T_J = 125\text{ }^\circ\text{C}$		2.2		

.....continued

Symbol	Characteristic	Test Conditions	Min.	Typ.	Max.	Unit
I _{CEs}	Collector cut-off current ¹	V _{CE} = 900 V, V _{GE} = 0 V			450	μA
		V _{CE} = 900 V, V _{GE} = 0 V, T _J = 125 °C			1350	
I _{GES}	Gate-emitter leakage current	V _{GE} = ±30 V			±100	nA

Note:

1. I_{CEs} includes both IGBT and diode leakages.

The following table shows the dynamic characteristics of this device. T_C = 25 °C unless otherwise specified.

Table 1-4. Dynamic Characteristics

Symbol	Characteristic	Test Conditions	Min.	Typ.	Max.	Unit
C _{ies}	Input capacitance	V _{GE} = 0 V, V _{CE} = 25 V, f = 1 MHz		4170		pF
C _{res}	Reverse transfer capacitance			63		
C _{oes}	Output capacitance			438		
V _{GEP}	Gate-to-emitter plateau voltage	Gate charge		7.5		V
Q _G	Total gate charge ¹	V _{GE} = 15 V, V _{CE} = 50 V, I _C = 47 A		698		nC
Q _{GE}	Gate-emitter charge			380		
Q _{GC}	Gate-collector ("Miller") charge			50		
SSOA	Switching safe operating area	T _J = 150 °C, R _G = 5 Ω, V _{GE} = 15 V, V _{CE} = 900 V, L = 100 μH	136			A
t _{d(on)}	Turn-on delay time	V _{CC} = 600 V, V _{GE} = 15 V, I _C = 47 A, R _G = 4.7 Ω, T _J = 25 °C		18		ns
t _r	Current rise time			26		
t _{d(off)}	Turn-off delay time			153		
t _f	Current fall time			45		
E _{on}	Turn-on switching energy ²				1296	
E _{off}	Turn-off switching energy ³			1540		
t _{d(on)}	Turn-on delay time	V _{CC} = 600 V, V _{GE} = 15 V, I _C = 47 A, R _G = 4.7 Ω, T _J = 125 °C		17		ns
t _r	Current rise time			27		
t _{d(off)}	Turn-off delay time			199		
t _f	Current fall time			166		
E _{on}	Turn-on switching energy ²				1318	
E _{off}	Turn-off switching energy ³			1704		

Notes:

1. See MIL-STD-750 Method 3471.
2. E_{on} is the clamped inductive turn-on-energy of this device; there is no contribution to E_{on} from the SiC diode. (See Figures 1-21, 1-22.)
3. E_{off} is the clamped inductive turn-off energy measured in accordance with JEDEC standard JESD24-1. (See Figures 1-21, 1-23.)

1.4 Typical Performance Curves

Data for performance curves are characterized, not 100% tested.

Figure 1-1. Output Characteristics

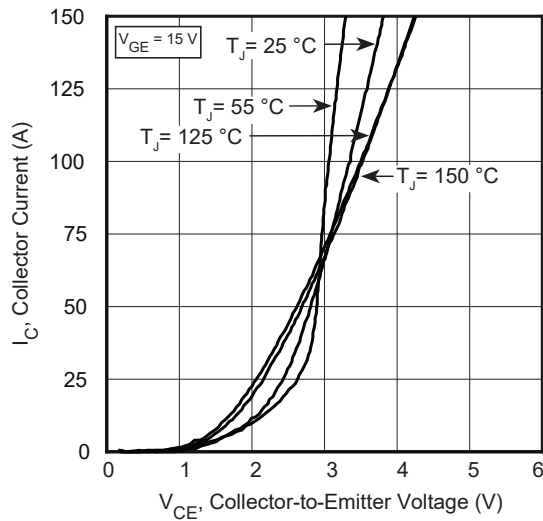

Figure 1-2. Output Characteristics

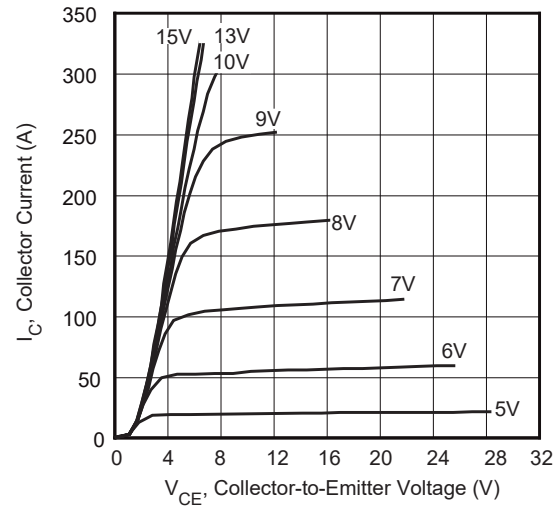

Figure 1-3. Transfer Characteristics

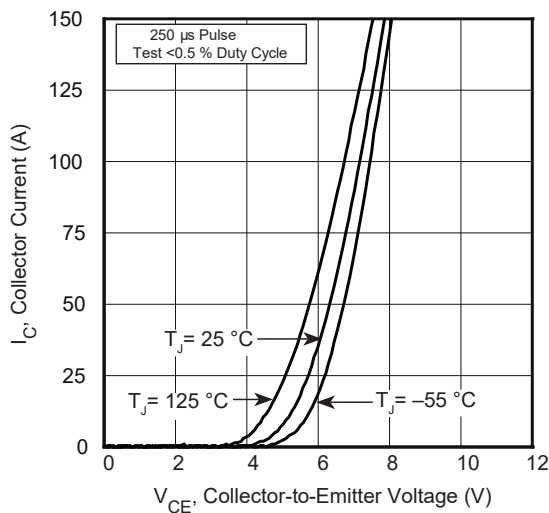

Figure 1-4. Gate Charge

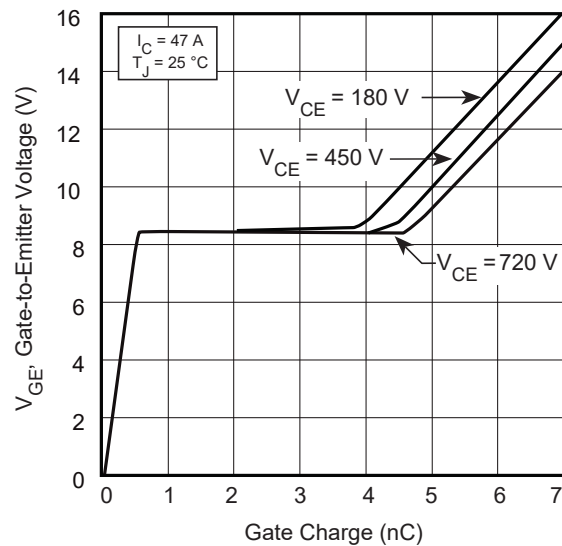

Figure 1-5. On-State Voltage vs. Gate-to- Emitter Voltage

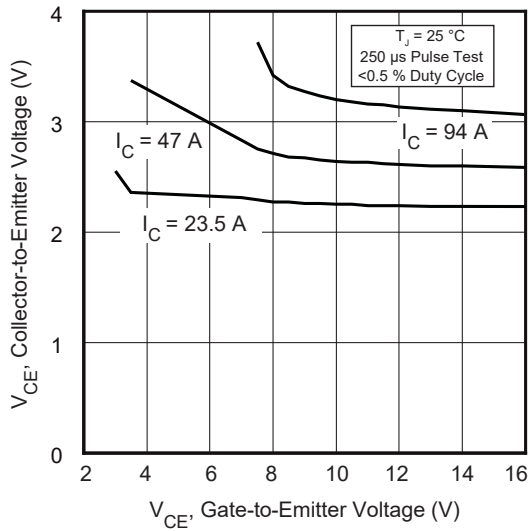

Figure 1-6. On-State Voltage vs. Junction Temperature

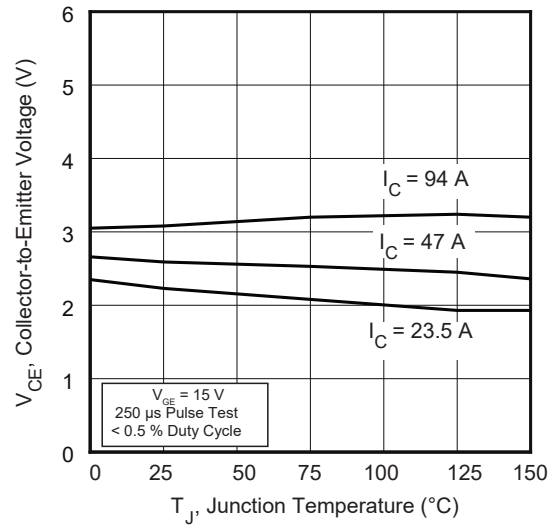

Figure 1-7. Threshold Voltage vs. Junction Temperature

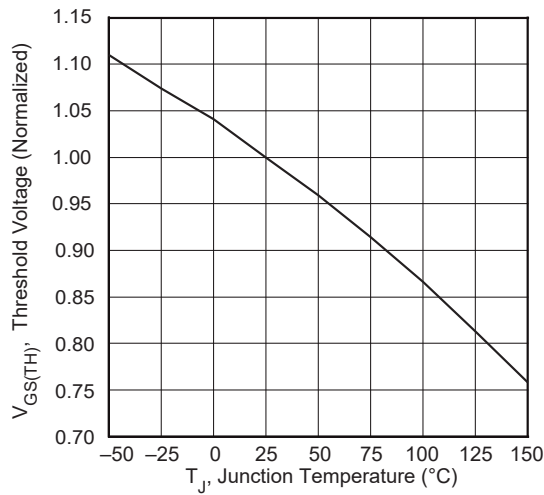

Figure 1-8. DC Collector Current vs. Case Temperature

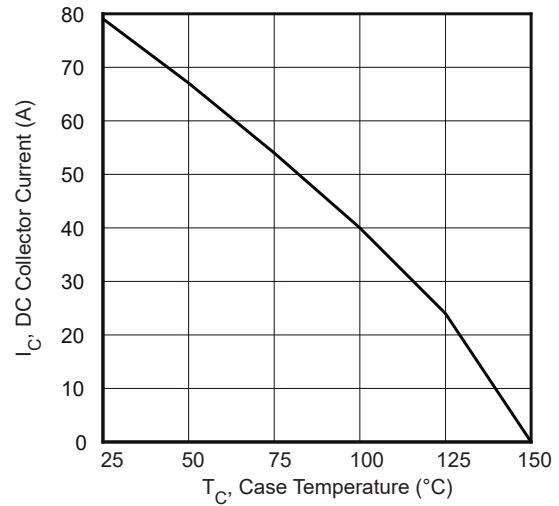

Figure 1-9. Turn-On Delay Time vs. Collector Current

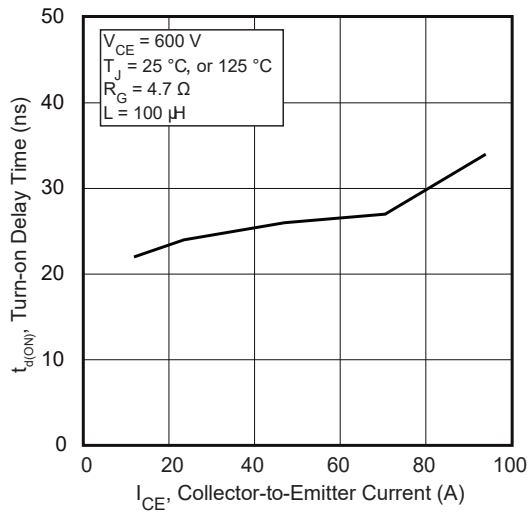

Figure 1-10. Turn-Off Delay Time vs. Collector Current

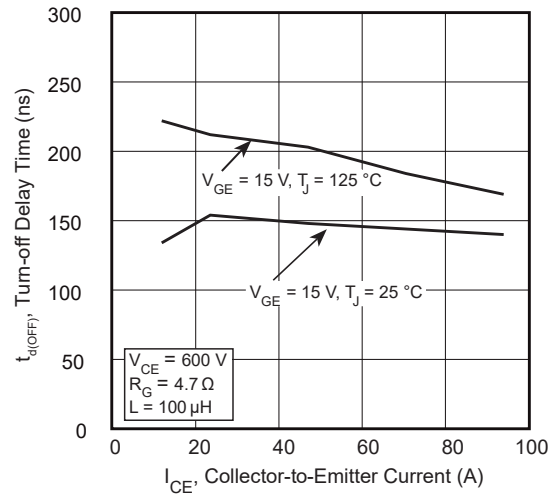

Figure 1-11. Current Rise Time vs. Collector Current

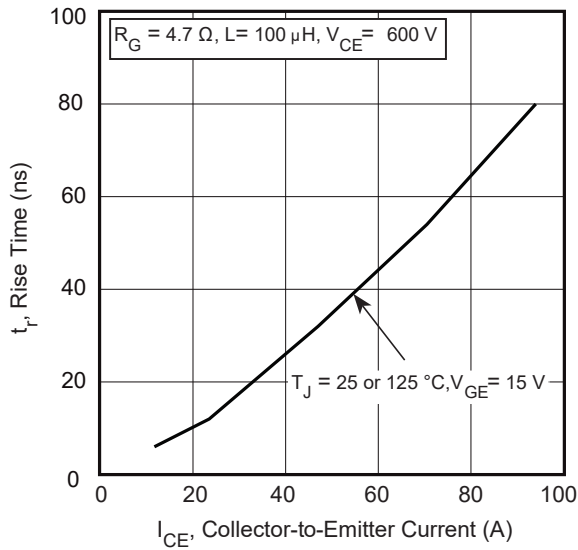

Figure 1-12. Current Fall Time vs. Collector Current

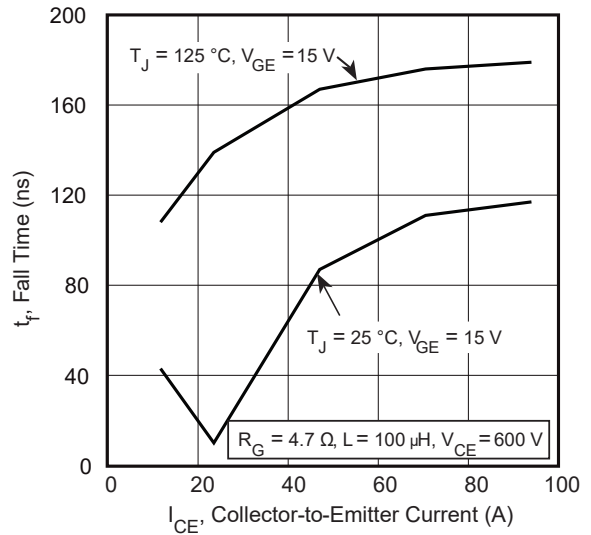

Figure 1-13. Turn-On Energy Loss vs. Collector Current

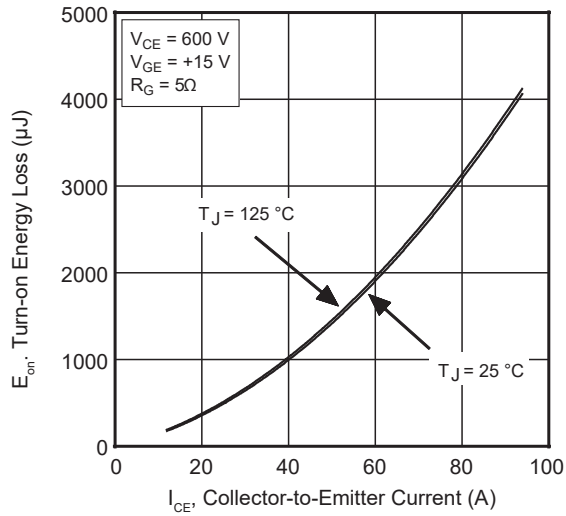

Figure 1-14. Turn-Off Energy Loss vs. Collector Current

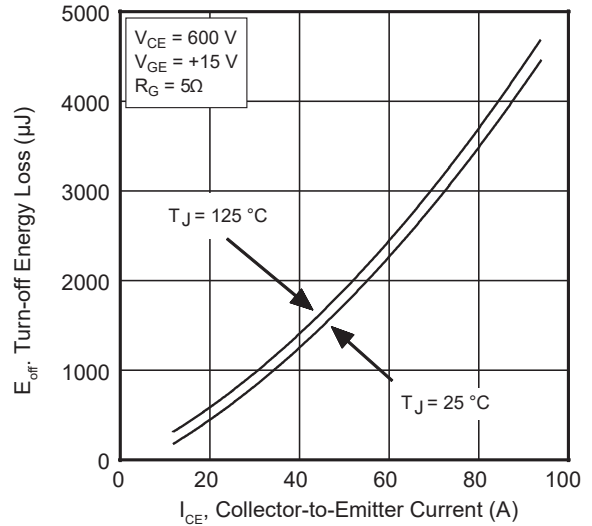

Figure 1-15. Switching Energy Losses vs. Gate Resistance

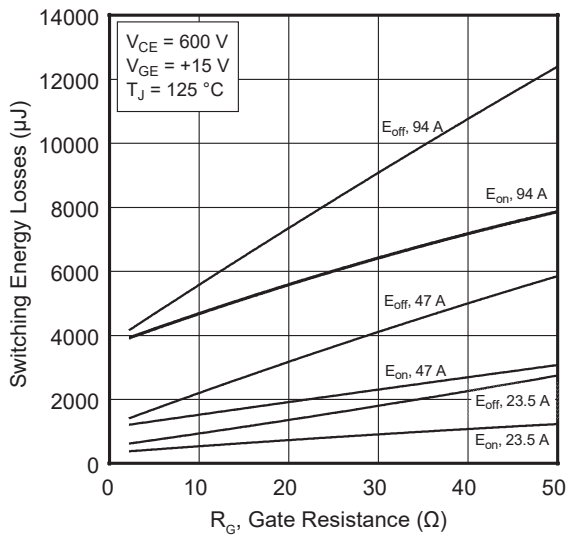

Figure 1-16. Switching Energy Losses vs. Junction Temperature

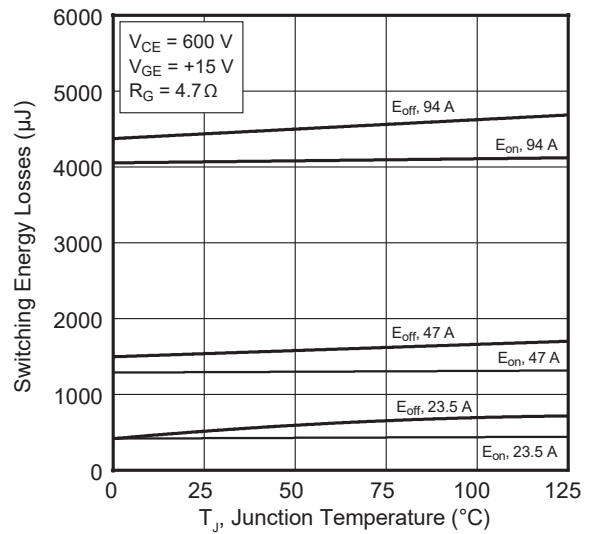

Figure 1-17. Capacitance vs. Collector-To-Emitter Voltage **Figure 1-18.** Switching Safe Operating Area

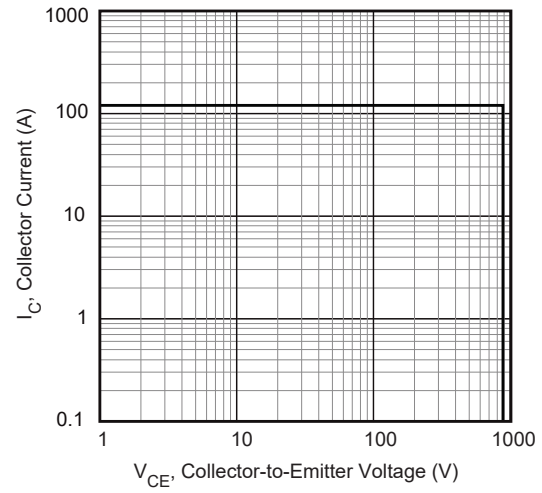
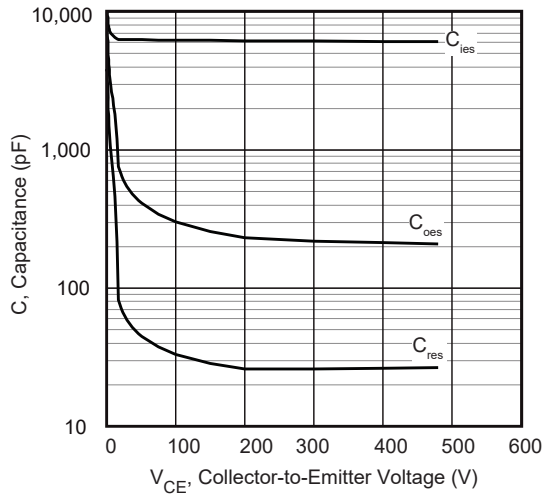

Figure 1-19. Maximum Transient Thermal Impedance

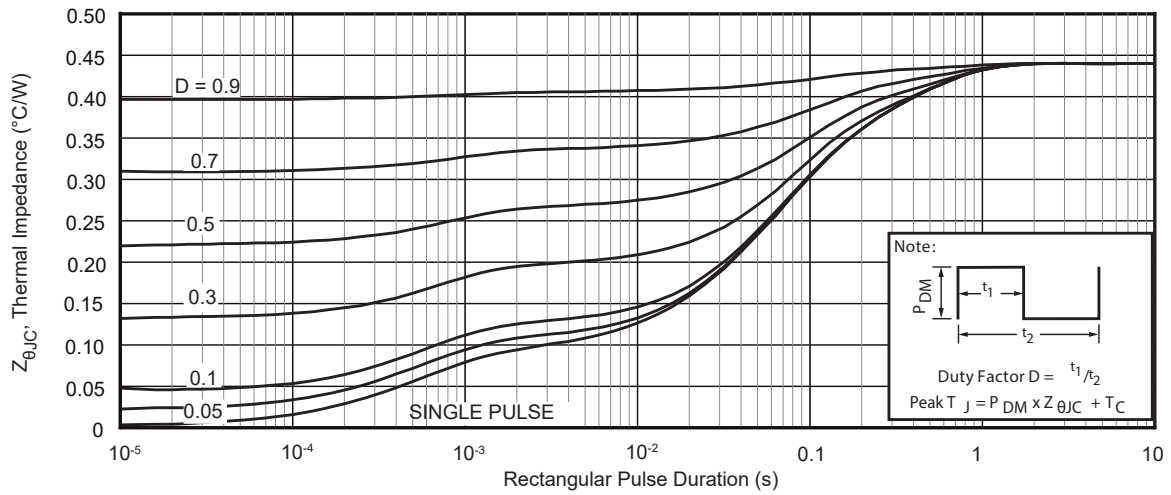

Figure 1-20. Transient Thermal Impedance Model

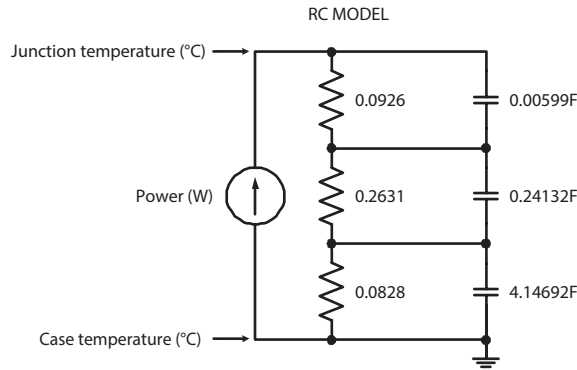

Figure 1-21. Inductive Switching Test Circuit

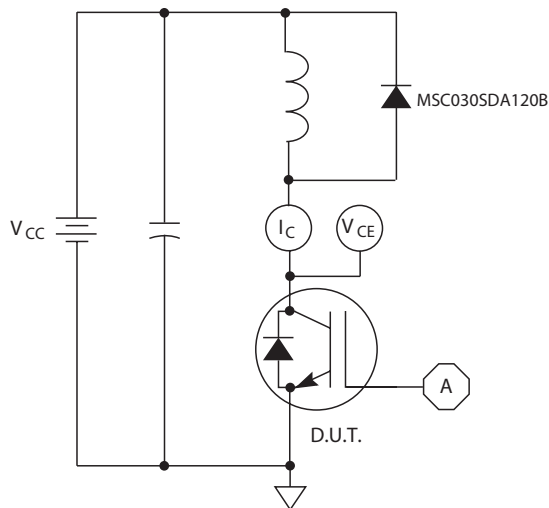

Figure 1-22. Turn-on Switching Waveform and Definitions

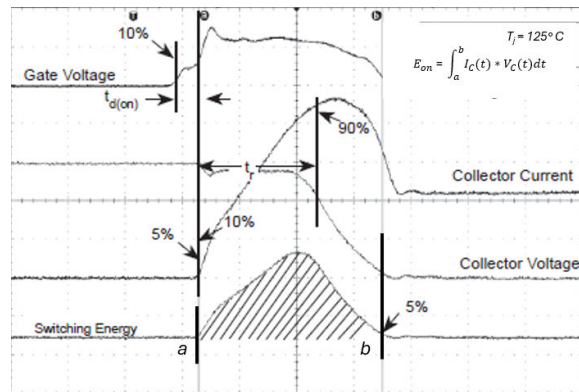
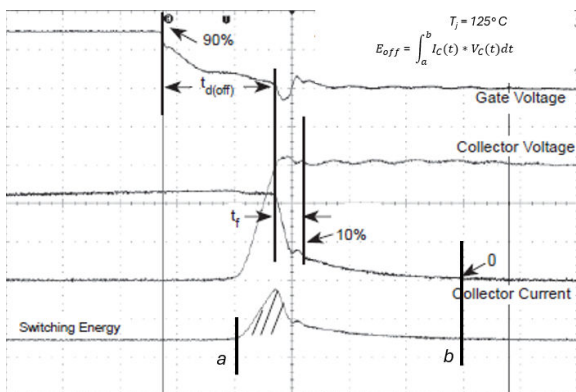

Figure 1-23. Turn-off Switching Waveform and Definitions



2. Device Specifications: Zero-Recovery SiC Anti-Parallel Diode

This section shows the specifications of the co-packaged, anti-parallel diode.

2.1 Absolute Maximum Ratings

The following table shows the absolute maximum ratings of the anti-parallel diode. $T_C = 25\text{ }^\circ\text{C}$ unless otherwise specified.

Table 2-1. Absolute Maximum Ratings

Symbol	Parameter	Ratings	Unit
I_F	Maximum DC forward current ($T_C = 25\text{ }^\circ\text{C}$)	65	A
	Maximum DC forward current ($T_C = 135\text{ }^\circ\text{C}$)	29	
	Maximum DC forward current ($T_C = 145\text{ }^\circ\text{C}$)	24	
I_{FRM}	Repetitive peak forward surge current ($t_p = 8.3\text{ ms}$, half sine wave)	92	
I_{FSM}	Non-repetitive forward surge current ($t_p = 8.3\text{ ms}$, half sine wave)	165	
P_{TOT}	Total power dissipation ($T_C = 25\text{ }^\circ\text{C}$)	259	W
	Total power dissipation ($T_C = 110\text{ }^\circ\text{C}$)	112	

2.2 Electrical Performance

The following table shows the static characteristics of the anti-parallel diode.

Table 2-2. Static Characteristics

Symbol	Characteristic	Test Conditions	Min	Typ	Max	Unit
V_F	Forward voltage	$I_F = 30\text{ A}$, $T_J = 25\text{ }^\circ\text{C}$		1.5	1.8	V
		$I_F = 30\text{ A}$, $T_J = 175\text{ }^\circ\text{C}$		2.1		

2.3 Typical Performance Curves

Data for performance curves are characterized, not 100% tested.

Figure 2-1. Maximum Transient Thermal Impedance

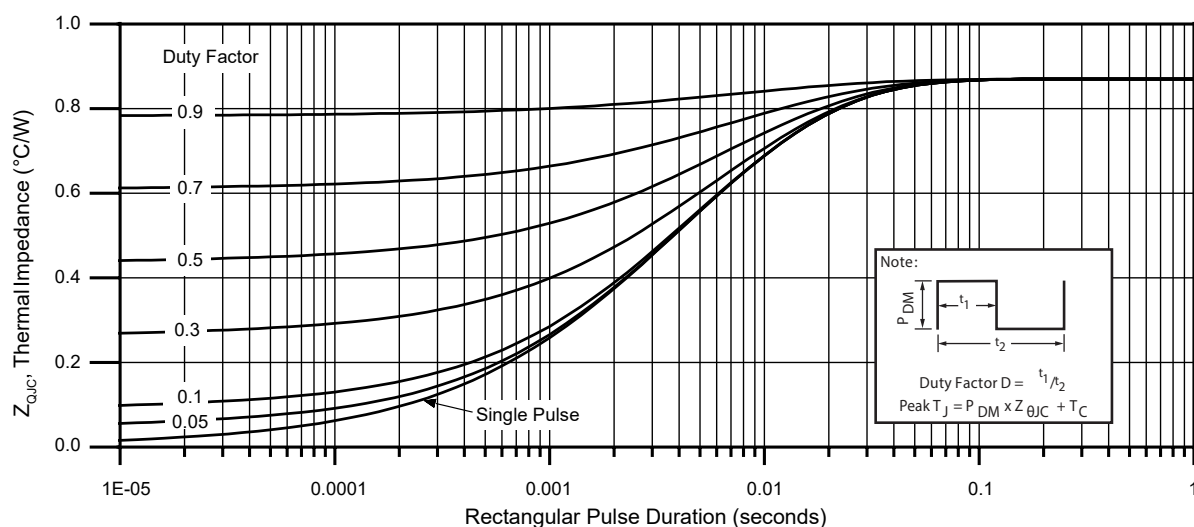

Figure 2-2. Forward Current vs. Forward Voltage

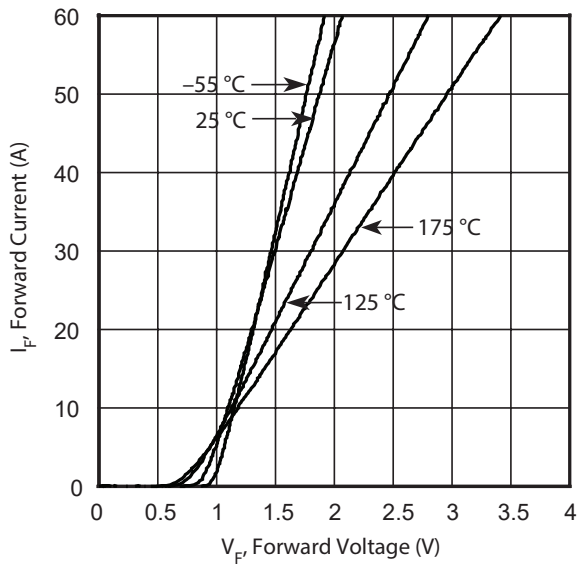

Figure 2-3. Max. Forward Current vs. Case Temp.

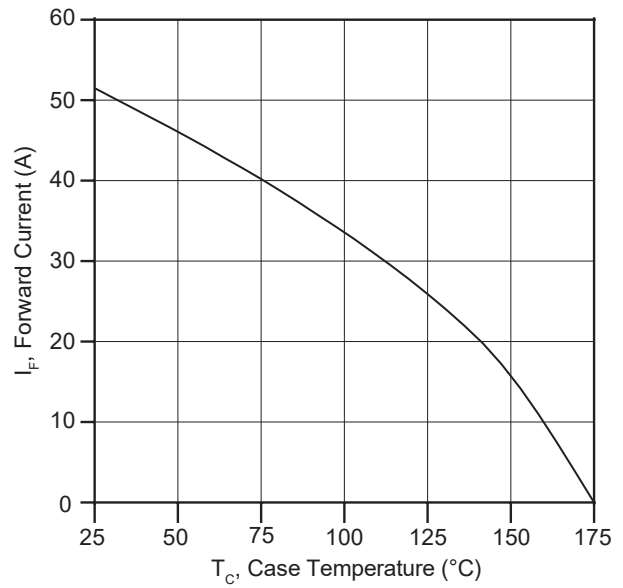

Figure 2-4. Max. Power Dissipation vs. Case Temp.

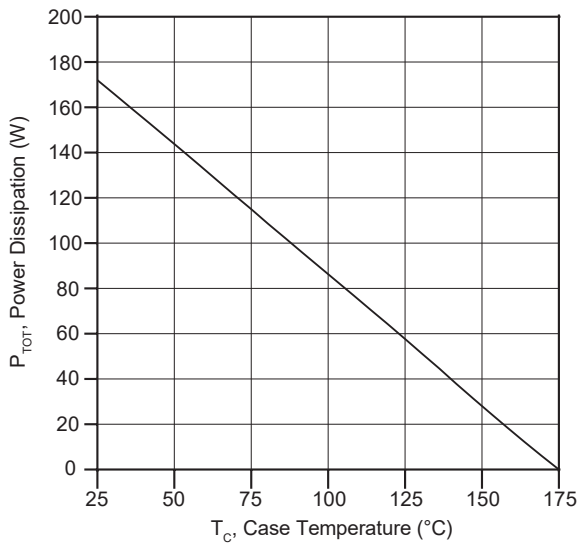

Figure 2-5. Total Capacitive Charge vs. Reverse Voltage

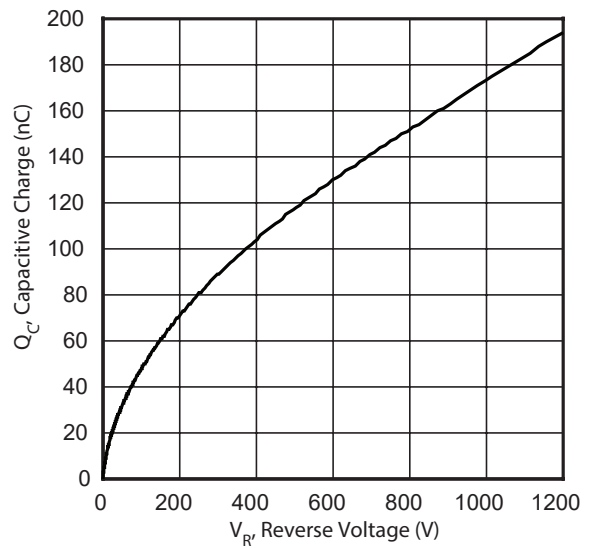
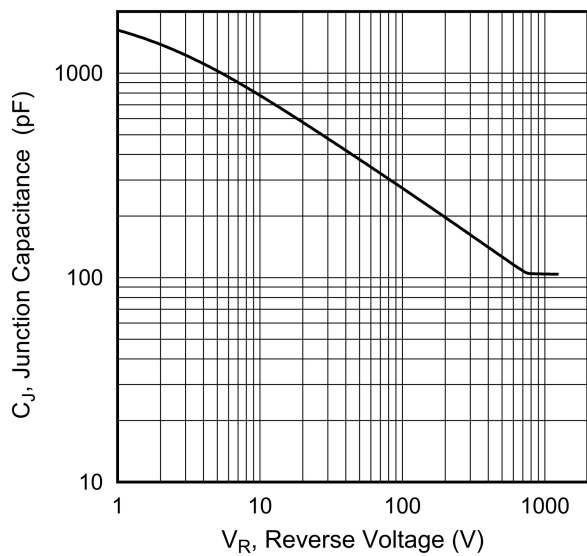

Figure 2-6. Junction Capacitance vs. Reverse Voltage



3. Package Specification

This section shows the package specification of this device.

3.1 Package Outline Drawing

The following figure illustrates the SOT-227 package outline of this device.

Figure 3-1. Package Outline Drawing

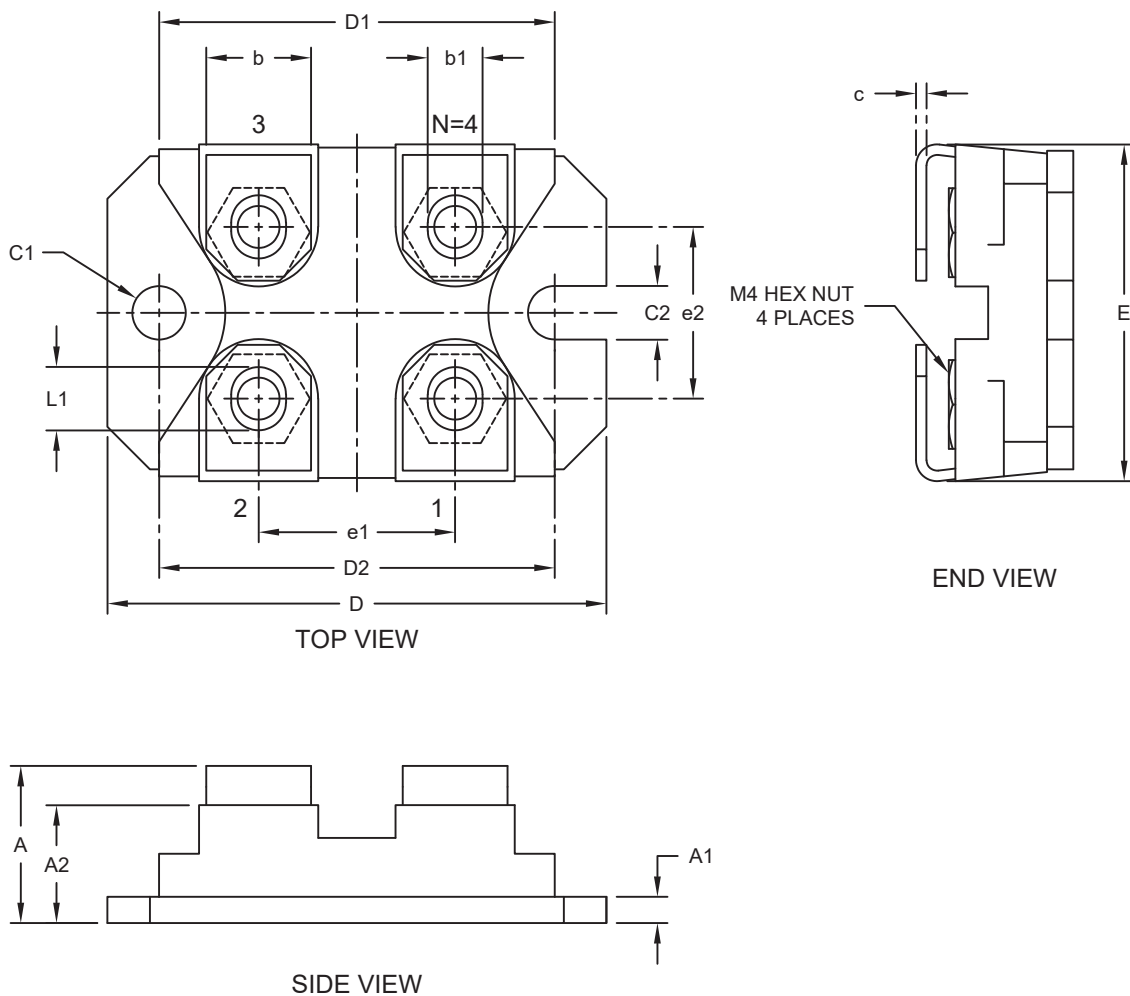

The following table shows the SOT-227 dimensions and should be used in conjunction with the package outline drawing.

Table 3-1. SOT-227 Dimensions

Dimension Limits		Dimensions (millimeters)	
		Min.	Max.
Number of terminals	N		4
Terminal pitch	e1	14.9	15.1
Terminal pitch	e2	12.6	12.8
Overall height	A	11.8	12.2
Base plate thickness	A1	1.95	2.14

.....continued

Dimension Limits		Dimensions (millimeters)	
		Min.	Max.
Molded package thickness	A2	8.9	9.6
Overall length	D	38.0	38.2
Molded package length	D1	31.5	31.7
Mounting centers	D2	30.1	30.3
Overall width	E	25.2	25.4
Terminal width	b	7.8	8.2
Terminal thickness	c	0.75	0.85
Terminal slot width	b1	4.1	4.3
Terminal slot length	L1	4.8	4.9
Mounting hole diameter	C1	4.0	4.2
Mounting slot width	C2	4.0	4.2

Note:

1. Dimensioning and tolerancing per ASME Y14.5M.

3.2 Terminal Pinout

The following figure illustrates the terminal pinout of this device.

Figure 3-2. Terminal Pinout

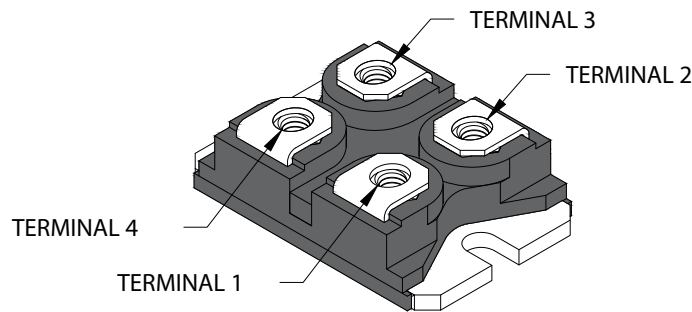

The following table shows the electrical signal terminal pinout of this device.

Table 3-2. Electrical Signal Terminal Pinout

Terminal	Definition
TERMINAL 1	Gate
TERMINAL 2	Collector, Diode Cathode
TERMINAL 3	Emitter, Diode Anode
TERMINAL 4	Emitter, Diode Anode

4. Revision History

The revision history describes the changes that were implemented in the document. The changes are listed by revision, starting with the most current publication.

Table 4-1. Revision History

Revision	Date	Description
A	02/2025	Document created.

Microchip Information

Trademarks

The “Microchip” name and logo, the “M” logo, and other names, logos, and brands are registered and unregistered trademarks of Microchip Technology Incorporated or its affiliates and/or subsidiaries in the United States and/or other countries (“Microchip Trademarks”). Information regarding Microchip Trademarks can be found at <https://www.microchip.com/en-us/about/legal-information/microchip-trademarks>.

ISBN: 979-8-3371-0601-4

Legal Notice

This publication and the information herein may be used only with Microchip products, including to design, test, and integrate Microchip products with your application. Use of this information in any other manner violates these terms. Information regarding device applications is provided only for your convenience and may be superseded by updates. It is your responsibility to ensure that your application meets with your specifications. Contact your local Microchip sales office for additional support or, obtain additional support at www.microchip.com/en-us/support/design-help/client-support-services.

THIS INFORMATION IS PROVIDED BY MICROCHIP “AS IS”. MICROCHIP MAKES NO REPRESENTATIONS OR WARRANTIES OF ANY KIND WHETHER EXPRESS OR IMPLIED, WRITTEN OR ORAL, STATUTORY OR OTHERWISE, RELATED TO THE INFORMATION INCLUDING BUT NOT LIMITED TO ANY IMPLIED WARRANTIES OF NON-INFRINGEMENT, MERCHANTABILITY, AND FITNESS FOR A PARTICULAR PURPOSE, OR WARRANTIES RELATED TO ITS CONDITION, QUALITY, OR PERFORMANCE.

IN NO EVENT WILL MICROCHIP BE LIABLE FOR ANY INDIRECT, SPECIAL, PUNITIVE, INCIDENTAL, OR CONSEQUENTIAL LOSS, DAMAGE, COST, OR EXPENSE OF ANY KIND WHATSOEVER RELATED TO THE INFORMATION OR ITS USE, HOWEVER CAUSED, EVEN IF MICROCHIP HAS BEEN ADVISED OF THE POSSIBILITY OR THE DAMAGES ARE FORESEEABLE. TO THE FULLEST EXTENT ALLOWED BY LAW, MICROCHIP’S TOTAL LIABILITY ON ALL CLAIMS IN ANY WAY RELATED TO THE INFORMATION OR ITS USE WILL NOT EXCEED THE AMOUNT OF FEES, IF ANY, THAT YOU HAVE PAID DIRECTLY TO MICROCHIP FOR THE INFORMATION.

Use of Microchip devices in life support and/or safety applications is entirely at the buyer’s risk, and the buyer agrees to defend, indemnify and hold harmless Microchip from any and all damages, claims, suits, or expenses resulting from such use. No licenses are conveyed, implicitly or otherwise, under any Microchip intellectual property rights unless otherwise stated.

Microchip Devices Code Protection Feature

Note the following details of the code protection feature on Microchip products:

- Microchip products meet the specifications contained in their particular Microchip Data Sheet.
- Microchip believes that its family of products is secure when used in the intended manner, within operating specifications, and under normal conditions.
- Microchip values and aggressively protects its intellectual property rights. Attempts to breach the code protection features of Microchip products are strictly prohibited and may violate the Digital Millennium Copyright Act.
- Neither Microchip nor any other semiconductor manufacturer can guarantee the security of its code. Code protection does not mean that we are guaranteeing the product is “unbreakable”. Code protection is constantly evolving. Microchip is committed to continuously improving the code protection features of our products.