



Precision 1:8 LVPECL Fanout Buffer with 2:1 Runt Pulse Eliminator Input MUX

SY89837U Evaluation Board

General Description

The SY89837U evaluation board is designed for convenient setup and quick evaluation of the SY89837U. The boards are optimized to interface directly to a 50Ω oscilloscope.

For best AC performance, the boards are configured in AC-coupled In/AC-coupled Out configuration. For applications that require a DC-coupled configuration, step-by-step instructions for modifying the board are included.

Features

- Fully assembled and tested SY89837U
- +2.5V or +3.3V power supply
- AC-coupled configuration for ease-of-use
- I/O interface includes on-board termination
- Fully assembled and tested
- Can be reconfigured for DC-coupling operation

Related Documentation

- SY89837U, Precision 1:8 LVPECL Fanout Buffer with 2:1 Runt Pulse Eliminator Input MUX

Evaluation Board

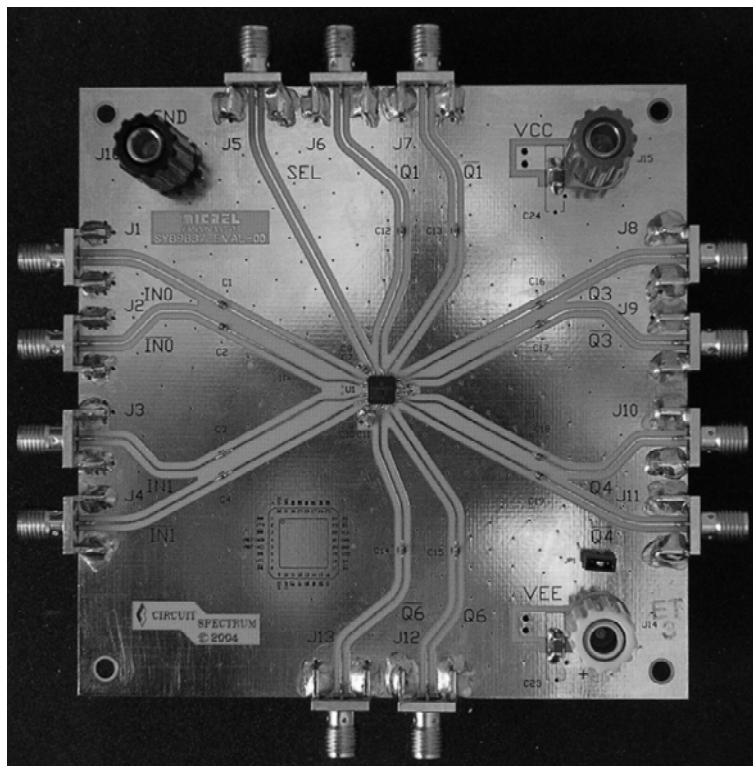

Evaluation Board Description

The default configuration for the SY89837U board is the AC-coupled. The choice between AC- and DC-coupled configurations offers the user flexibility for specific applications.

AC-Coupled Evaluation Board

The AC-coupled configuration is suited to most customer applications and is preferred by the majority of users because of its ease-of-use. It requires only a single power supply and offers the most flexibility in interfacing to a variety of signal sources.

The DC-bias levels and AC-coupling capacitors are supplied on-board for each input, making it unnecessary to vary the offset voltage or change any components on the board as the power supply voltage varies over the +2.5V \pm 5% and +3.3V \pm 10% operating range. The user needs only to supply a minimum input voltage swing and the bias voltage will automatically adjust the input to the correct level as the power supply voltage varies.

DC-Coupled Evaluation Board

For applications that are not suited to AC-coupling such as clock that can be turned off for extended periods of time, the board can be user-configured for DC-coupled operation.

This can be accomplished by modifying the board to use two power supplies into a "split-supply configuration." Since LVPECL is referenced to V_{CC} ,

and standard PECL termination is 50 Ω to $V_{CC}-2V$, split-supply is an easy method to interface to a 50 Ω (to ground) scope. Therefore, a 3.3V supply will be split into +2V and -1.3V, and a 2.5V supply will be split into a +2V and -0.5V.

The +2V offset in this two-power supply configuration then provides the correct terminations for the device by setting the Ground potential on the board to be exactly 2 volts below the V_{CC} supply. The V_{EE} voltage is then set to -1.3V for 3.3V devices, or -0.5V for 2.5V devices to ensure proper V_{CC} to V_{EE} voltage difference.

Runt Pulse Eliminator Input

The SY89837U evaluation board allows the user to test the Runt Pulse Eliminator function. The Runt Pulse Eliminator function prevents any short cycles or "runt" pulses during switchover.

To see the effects of the Runt Pulse Eliminator function, disable it by replacing C11 with a 0 Ω resistor. Sweep the frequency of the function generator to see runt pulses develop. Enable the Runt Pulse Eliminator function by restoring C11, and perform the same frequency sweep.

Any-Input Interface

The unique internal input termination sets the input common mode voltage. This enables the input to interface with any differential signal over the supply voltage without modifying the board.

Evaluation Board

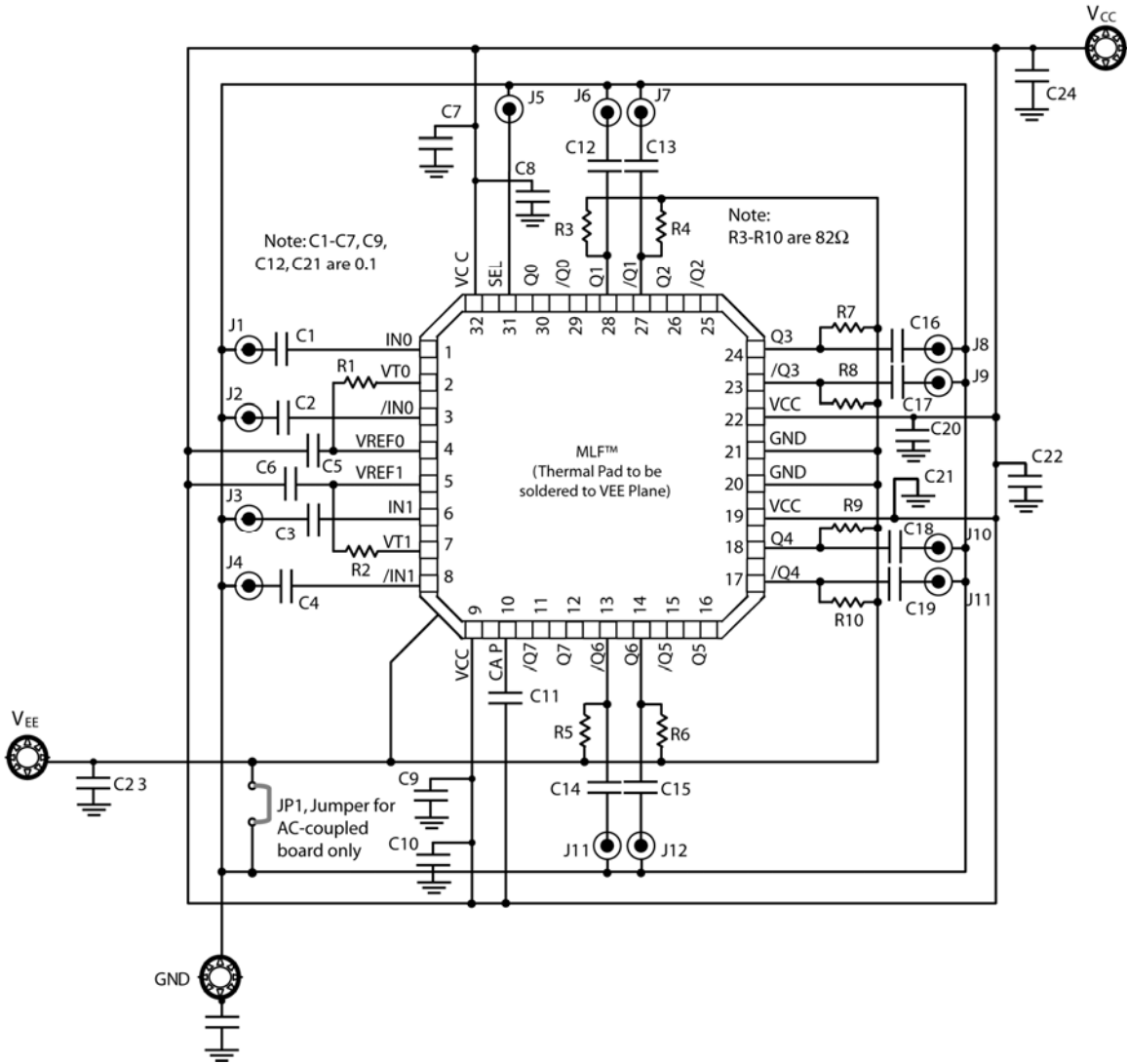

SY89837U AC-Coupled Evaluation Board

Power Supply	V _{CC}	GND	V _{EE}	I/O
2.5 Volt System	+2.5V	0V	0V	AC-coupled Input/AC-coupled Output
3.3 Volt System	+3.3V	0V	0V	AC-coupled Input/AC-coupled Output

Table 1. AC-Coupled Evaluation Board Power Supply Connections

Evaluation Board

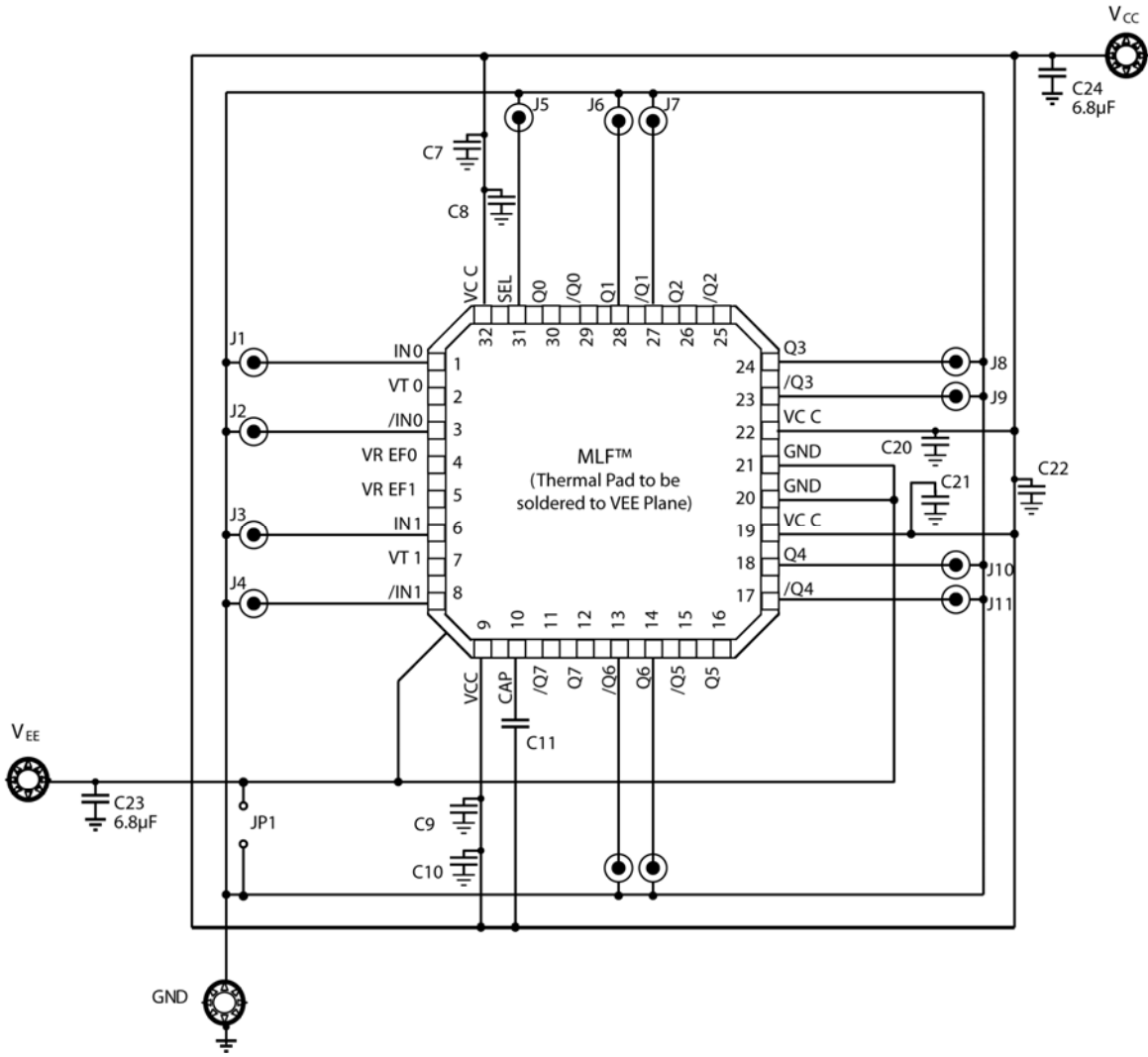

SY89837U DC-Coupled Evaluation Board

Power Supply	V _{CC}	GND	V _{EE}	I/O
2.5 Volt System	+2V	0V	-0.5V	AC-Coupled Input/DC-Coupled Output
3.3 Volt System	+2V	0V	-1.3V	AC-Coupled Input/DC-Coupled Output

Table 2. DC-Coupled Evaluation Board Power Supply Connections

AC-Coupled Evaluation Board Setup

Setting up the SY89837U AC-coupled Evaluation Board

The following steps describe the procedure for setting up the evaluation board:

1. Set the voltage setting for a DC supply to be either 2.5V or 3.3V depending on your application and turn off the supply.
2. Connect the GND terminal to the negative side of a DC power supply. This is the 0V ground potential.
3. Connect the V_{CC} terminal to the positive side of a DC power supply.
4. Turn on the power supply and verify the power supply current is $<160\text{mA}$.
5. Turn off the power supply.
6. Using a differential signal source set the amplitude of each side of the differential pair to be 800mV (1600mV measured differentially). Set the offset to be a positive value, the value of this offset is not critical, as the AC-coupled inputs will be automatically biased to the correct offset.
7. Turn off or disable the outputs of the signal source.
7. Using a 50Ω impedance coaxial cable, DC-couple the function generator with TTL/CMOS level (referenced to V_{EE}) signal to the SEL input on the evaluation board (J5).
8. Using equal length 50Ω impedance coaxial cables, connect the signal source to the inputs on the evaluation board (J1 and J2 or J3 and J4).
9. Using equal length 50Ω impedance coaxial cables, connect the outputs of the evaluation board (J6 and J7 or J8 and J9 or J10 and J11 or J12 and J13) to the oscilloscope or other measurement device that has an internal 50Ω termination. Any of these 8 outputs that are not connected to a scope or other instrument should be terminated with a 50Ω to ground at the SMA on the board.
10. Turn on the power supply and verify the current is $<200\text{mA}$.
11. Enable the signal source and monitor the outputs.

Modifying AC-Coupled Outputs for DC-Coupled Operation

When DC-coupling is Necessary

For applications where AC-coupling is not appropriate, the board can be reconfigured for DC-coupled operation. An example where DC-coupling is required is if the input data or clock can be disabled. This would result in a DC-signal at the inputs and the on-board biasing resistors (R1 and R2) would apply the same level to both the true and complement inputs. Since these inputs are differential this would result in an intermediate non-differential state at the inputs and the outputs would be in an indeterminate condition. Reconfiguring the board for DC-coupled operation and using two power supplies can avoid this condition.

Reconfiguring an AC-coupled Board into a DC-coupled Board

The following procedure details the steps for converting an AC-coupled board to a DC-coupled board:

1. Remove Shorting Jumper JP1.
2. Remove resistors R1 through R10.
3. Remove capacitors C5 and C6.
4. Replace capacitors C1–C4 and C12–C19 with 0Ω resistors.

Setting up the DC-Coupled Evaluation Board

The following steps describe the procedure for setting up the DC-Coupled evaluation board:

1. Set the voltage for DC supply number 1 to be 2.0V and connect it to J15 (V_{CC}).
2. Set the voltage for DC supply number 2 to be -1.3V (for 3.3V operation) or -0.5V (for 2.5V operation) and connect it to J14 (V_{EE}).
3. Connect the negative side of power supply 1 to the positive side of power supply 2. This is the 0V ground potential for the board.
4. Turn off the power supplies and connect the GND terminal on the board, J16, to the negative side of a DC power supply 1 and the positive side of DC power supply 2
5. Turn on the power supply and verify that the power supply current is <160mA. Using a voltmeter.

6. Turn off the power supply.
7. Using a function generator.
8. Using a 50Ω impedance coaxial cable, DC-couple the function generator with TTL/CMOS level (referenced to V_{EE}) signal to the SEL input on the Evaluation Board (J5).
9. Disable the outputs of the differential signal source and set the $V_{OH} = V_{CC} - 1.0V$ and the $V_{OL} = V_{CC} - 1.75V$ as shown in the following table.

I/O Voltage Level	+3.3V Supply	+2.5V Supply
$V_{OH} = V_{CC} - 1.0V$	+2.3V	+1.5V
$V_{OL} = V_{CC} - 1.75V$	+1.55V	+0.75V

10. Using equal length 50Ω impedance coaxial cables, connect the outputs of the evaluation board (J6 and J7 or J8 and J9 or J10 and J11 or J12 and J13) to the oscilloscope or other measurement device that has an internal 50Ω termination. Any of these 8 outputs that are not connected to a scope or other instrument should be terminated with a 50Ω termination to ground at the SMA on the board.
11. Turn on the power and verify the current is <200mA.
12. Enable the signal source and monitor the outputs.

Evaluation Board Layout

PC Board Layout

The evaluation board is constructed with Rogers 4003 material for the Signal/GND layer and FR4 material for the other layers. The board is co-planar in design fabricated to minimize noise, achieve high bandwidth and minimize crosstalk.

L1	GND and Signal
L2	Impedance GND
L3	V_{CC}
L4	V_{EE} Power and GND

Table 3. Layer Stack

Bill of Materials

SY89837U AC-coupled Evaluation Board

Item	Part Number	Manufacturer	Description	Qty.
C1-C7, C9, C12-C21	VJ0402G104KXQ	Vishay ⁽¹⁾	0.1 μ F, 25V, 10% Ceramic Capacitor, Size 0402, X5R Dielectric	18
C8, C10, C22	VJ0402G103KXQ	Vishay ⁽¹⁾	0.01 μ F, 25V, 10% Ceramic Capacitor, Size 0402, X5R Dielectric	3
C11	VJ0402G474KXQ	Vishay ⁽¹⁾	0.47 μ F, 20V, Tantalum Electrolytic Capacitor, Size 0603	1
C23, C24	VJ0402G685KXQ	Vishay ⁽¹⁾	6.8 μ F, 16V, Tantalum Electrolytic Capacitor, Size B	2
R1, R2	CRCW060300R0F	Vishay ⁽¹⁾	0 Ω , 1/16W, 5% Thick-film Resistor, Size 0603	2
R3-R10	CRCW080582R5F	Vishay ⁽¹⁾	82 Ω , 1/10W, 5% Thick-film Resistor, Size 0805	2
J1-J13	142-0701-851	Johnson Components ⁽²⁾	Jack Assembly End Launch SMA	13
J14	111-0703-001	Johnson Components ⁽²⁾	Binding Post Black	1
J15	111-0702-001	Johnson Components ⁽²⁾	Binding Post Red	1
J16	111-0701-001	Johnson Components ⁽²⁾	Binding Post Green	1
JP1	929647-09-36-1	3M ⁽³⁾	0.025 Square Post	1
SB1	929055-06	3M ⁽³⁾	Shorting Jumper for use with JP1	1
U1	SY89837U	Micrel⁽⁴⁾	Precision 1:8 LVPECL Fanout Buffer with 2:1 Runt Pulse Eliminator Input MUX	1

Additional Bill of Materials for SY89837U DC-coupled Evaluation Board

Item	Part Number	Manufacturer	Description	Qty.
C1-C4, C12-C19	CRCW040200R0F	Vishay ⁽¹⁾	Replace capacitors with resistors: 0 Ω , 1/16W, 5% Thick-film Resistor, Size 0402	12

Notes:

1. Vishay: www.vishay.com.
2. Johnson Components: www.johnsoncomponents.com.
3. 3M: www.3m.com.
4. Micrel, Inc.: www.micrel.com.

HBW Support

Hotline: 408-955-1690

Email Support: HBWHelp@micrel.com

Application Hints and Notes

For application notes on high speed termination on PECL and LVPECL products, clock synthesizer products, SONET jitter measurement, and other High Bandwidth product go to Micrel Semiconductors website at <http://www.micrel.com/>. Once in Micrel's website, follow the steps below:

1. Click on "Product Info".
2. In the Applications Information Box, choose "Application Hints and Application Notes."

MICREL, INC. 2180 FORTUNE DRIVE SAN JOSE, CA 95131 USA
TEL +1 (408) 944-0800 FAX +1 (408) 474-1000 WEB <http://www.micrel.com>

The information furnished by Micrel in this data sheet is believed to be accurate and reliable. However, no responsibility is assumed by Micrel for its use. Micrel reserves the right to change circuitry and specifications at any time without notification to the customer.

Micrel Products are not designed or authorized for use as components in life support appliances, devices or systems where malfunction of a product can reasonably be expected to result in personal injury. Life support devices or systems are devices or systems that (a) are intended for surgical implant into the body or (b) support or sustain life, and whose failure to perform can be reasonably expected to result in a significant injury to the user. A Purchaser's use or sale of Micrel Products for use in life support appliances, devices or systems is a Purchaser's own risk and Purchaser agrees to fully indemnify Micrel for any damages resulting from such use or sale.

© 2004 Micrel, Incorporated.