

Off-Line Compact Universal Linear Regulator

Introduction

An off-line compact universal linear regulator is shown in Figure 1. The regulating device is the Supertex LND150N3. The LND1 is a 500V N-channel depletion mode MOSFET with gate-to-source ESD protection. The regulated voltage, V_{OUT} , is an ideal supply for CMOS ICs and a variety of other circuits that require low current.

Circuit Description

The 120V AC input voltage is rectified by a full bridge, consisting of diodes D_1 , D_2 , D_3 , and D_4 . A small filter or smoothing capacitor, C_1 , is used to hold the rectified voltage to approximately +170VDC.

The unregulated 170VDC is connected to the drain of the LND1. The LND1 and trim pot R_1 are configured as a 1.0mA constant current source. The 1.0mA constant current flows through R_2 which is a 5.1k Ω resistor to ground. A constant voltage drop of 5.1V is developed across R_2 . V_{OUT} is taken as the voltage across R_2 and is used to supply, for example, a simple CMOS timer circuit.

Capacitor C_2 is a low voltage bypass capacitor to supply any peak current required by the CMOS timer circuit during switching transitions. D_5 is a 5.6V Zener diode used to clamp transient voltages that may occur during powering up

the 120VAC input line. D_5 does not conduct during normal operation.

Calculations for Component Values

C_1 is a 0.1 μ F 200V capacitor, chosen to minimize ripple on the 170VDC which would affect the regulated output voltage. The minimum value of C_1 is calculated as follows:

$$V_{IN} = A \sin 2\pi f t; A = 170V, f = 60Hz$$

$$I = C_1 \frac{dv}{dt}; I = 1.0mA$$

$$dv = \Delta V = A - V_{OUT} - (I_{D(ON)} \cdot R_{DS(ON)}); dt = \Delta t = \frac{1}{2f}$$

$$C_1 \geq I \cdot \frac{\Delta t}{\Delta V} = 1.0mA \cdot \left(\frac{\frac{1}{2(60Hz)}}{170V - 5.1V - (10mA) \cdot (1K\Omega)} \right)$$

$$C_1 \geq 0.054\mu F$$

The LND1 can maintain a virtually constant current over a wide input voltage range. Large ripple voltages on the drain of the LND1 will have very little effect on the output current. The device can also withstand transient voltages up to 500V.

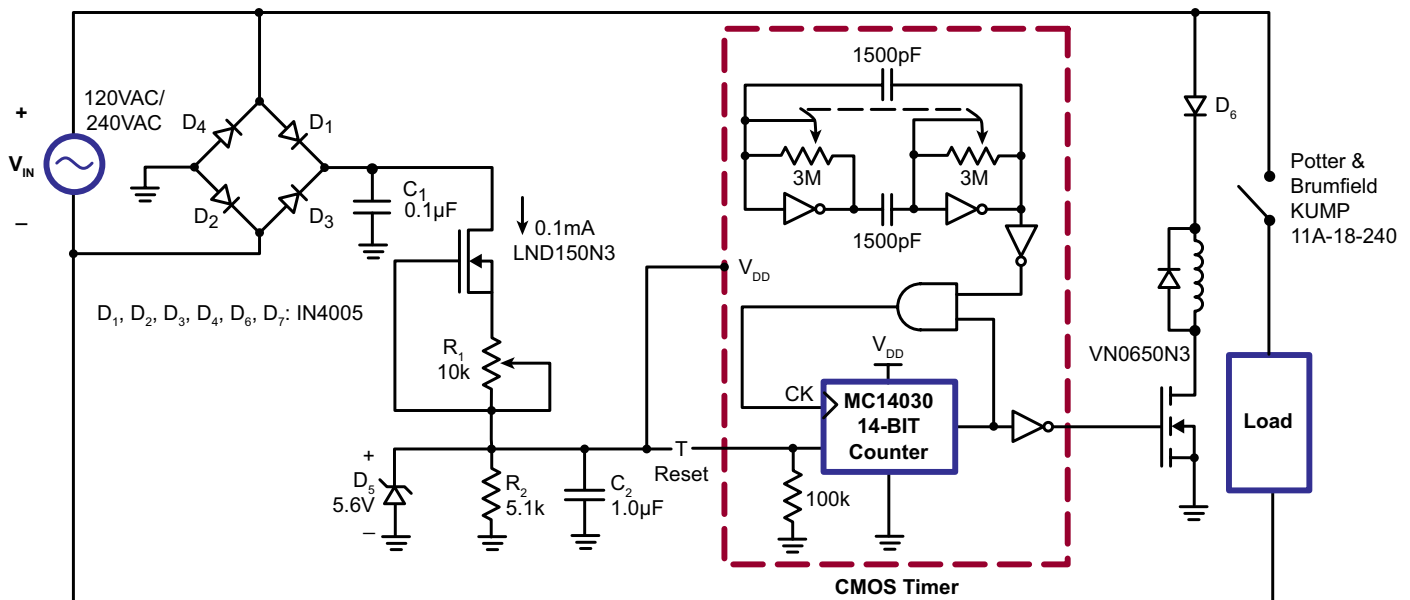

Figure 1. Linear Regulator

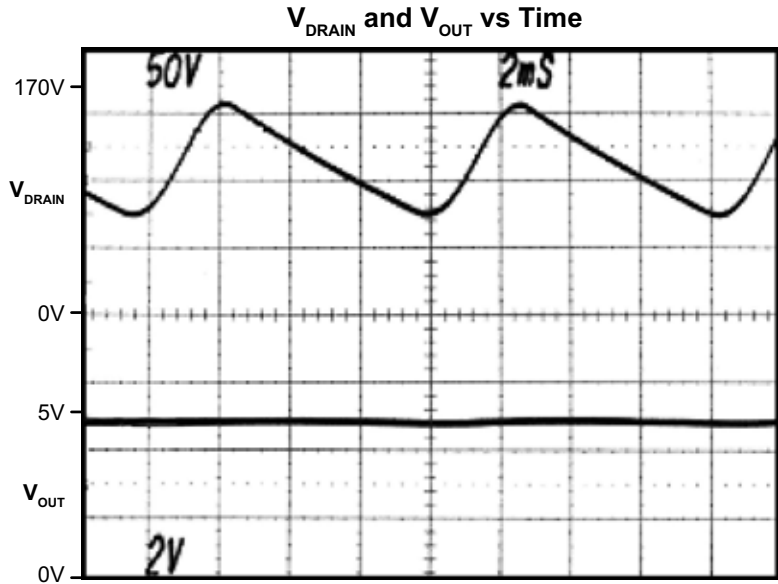

Figure 2. Input/ Output Waveforms

The value of the constant current source is a function of R_1 , $V_{GS(OFF)}$, and I_{DSS} where $V_{GS(OFF)}$ and I_{DSS} are characteristics of the device. R_1 is a variable resistor adjusted for 1.0mA and is approximated by:

$$R_1 = \frac{V_{GS(OFF)}}{I_D} \cdot (\sqrt{I_D / I_{DSS}} - 1)$$

Where,

- I_D = desired constant current value,
- $V_{GS(OFF)}$ = pinch-off voltage, and
- I_{DSS} = saturation current at $V_{GS} = 0$ V.

$V_{GS(OFF)}$ and I_{DSS} may vary from lot to lot. The range of adjustment for R_1 is calculated for operation over the range of LND1 values for $V_{GS(OFF)}$ and I_{DSS} .

Symbol	Parameter	Min	Max
$V_{GS(OFF)}$	Pinch-off voltage	-1.0V	-3.0V
I_{DSS}	Saturation current	-1.0mA	-3.0mA

For the above values, R_1 is calculated to be from 0 to 1.3k Ω . A 10k Ω trim pot is chosen for R_1 .

Since the constant current is adjusted to 1.0mA, R_2 is chosen to be 5.1k Ω to obtain a V_{OUT} of 5.1VDC. The value of C_2 is selected to supply the peak current required by the load

on V_{OUT} over a period of time. C_2 can be calculated as follows:

$$C_2 = I_{OUT} (dt / dV_{OUT}) \text{ where,}$$

- I_{OUT} = output current
- dt = required time duration of I_{OUT}
- dV_{OUT} = acceptable change in V_{OUT}

For example, a 10.0mA output peak current for a duration of 1.0 μ sec with a maximum V_{OUT} drop of 100mV will require a C_2 value of 1.0mA(1.0 μ sec/100mV) = 0.1 μ F or greater. C_2 is chosen to be 1.0 μ F.

Figure 2 is an oscilloscope picture showing the actual voltage waveforms on the drain of the LND1 and V_{OUT} .

Figure 3 is an output characteristic showing the regulation of the circuit over a wide range of input voltage.

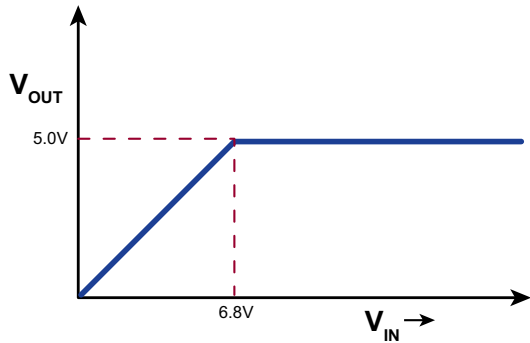

Figure 3. V_{OUT} vs V_{IN}

Alternative Applications

For a 10V source, R_2 can be replaced with a 10K Ω resistor. Applications requiring multiple voltage references can be generated using a string of resistors as shown in Figure 4.

The constant current can easily be changed by readjusting R_1 for the desired current. However, the power dissipation on the LND1 should be taken into consideration. P_D for the LND1 in the TO-92 package should not exceed:

$$I_{DS}(V_{IN} - V_{OUT}) = 600mW.$$

Universality

The universality of the linear regulator can benefit a variety of industrial or consumer applications as it can be used from a very wide range of input voltages, anywhere in the world. Input voltages can be up to 450V for linear regulation. Protection is afforded for line voltage transients up to

500V since the LND1 breakdown voltage is guaranteed to be greater than 500V. A simple, low cost, transient protection (e.g., MOV) will protect the circuit from virtually anything, other than a direct lightning strike.

Regulation can also be achieved with AC or DC voltages from 6.8 to 240V with no modifications of the circuit. This allows manufacture of one model of equipment for worldwide usage without any voltage setting tappings.

Conclusion

The Supertex LND1 can be configured as a simple, constant current source to create an economical compact off-line, low current regulated, voltage supply for powering CMOS ICs and other low current loads. The need for transformers can be eliminated.

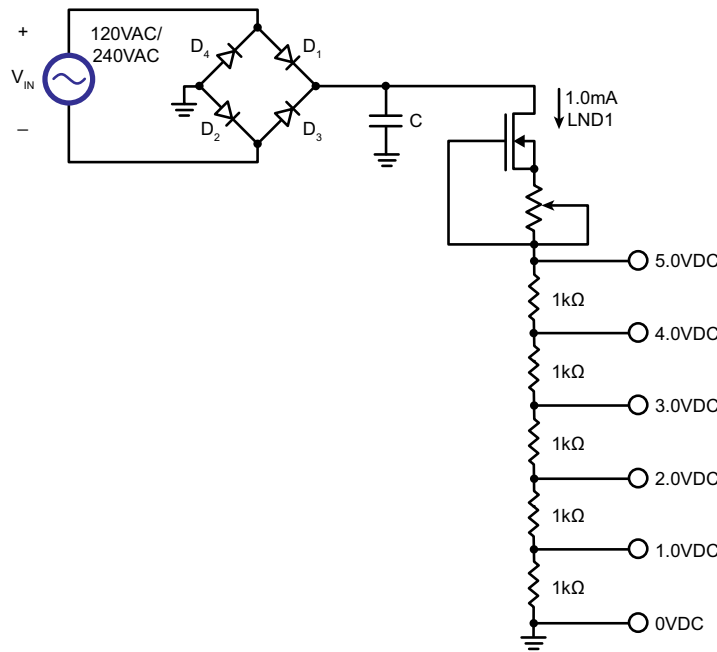

Figure 4. Multiple Voltage References

Supertex inc. does not recommend the use of its products in life support applications, and will not knowingly sell them for use in such applications unless it receives an adequate "product liability indemnification insurance agreement." **Supertex inc.** does not assume responsibility for use of devices described, and limits its liability to the replacement of the devices determined defective due to workmanship. No responsibility is assumed for possible omissions and inaccuracies. Circuitry and specifications are subject to change without notice. For the latest product specifications refer to the **Supertex inc.** (website: <http://www.supertex.com>)