

Bluetooth® Multi-Speaker Audio Application

INTRODUCTION

Microchip's Multi-Speaker Bluetooth Audio solution utilizes Microchip proprietary technology to connect a master speaker to one or multiple slave speakers through a modified Bluetooth protocol. Multi-speaker functionality is implemented using Microchip's BM6x family of modules. One (master) speaker can either be connected to an audio streaming Bluetooth device (smartphone, tablet, laptop, etc.) or its own auxiliary input (AUX/LINE-In jack), and re-transmit either of the two audio sources to one or more speakers acting as a slave.

Multi-speaker solutions can be used with Class 1 BM64 modules, which allow for extended range. This is a practical technology for applications such as PA conference systems or wireless audio throughout indoor or outdoor.

Multi-speaker can be provisioned to Concert mode (three or more speakers) or in Stereo mode (two speakers). For more details, refer to ["Demo Setup"](#) and ["Firmware Capabilities/Features"](#).

Figure 1 illustrates a typical Concert mode application where the master speaker is connected to an audio streaming device through Bluetooth.

FIGURE 1: CONCERT MODE: MASTER IS CONNECTED TO BLUETOOTH-ENABLED DEVICE THROUGH BLUETOOTH

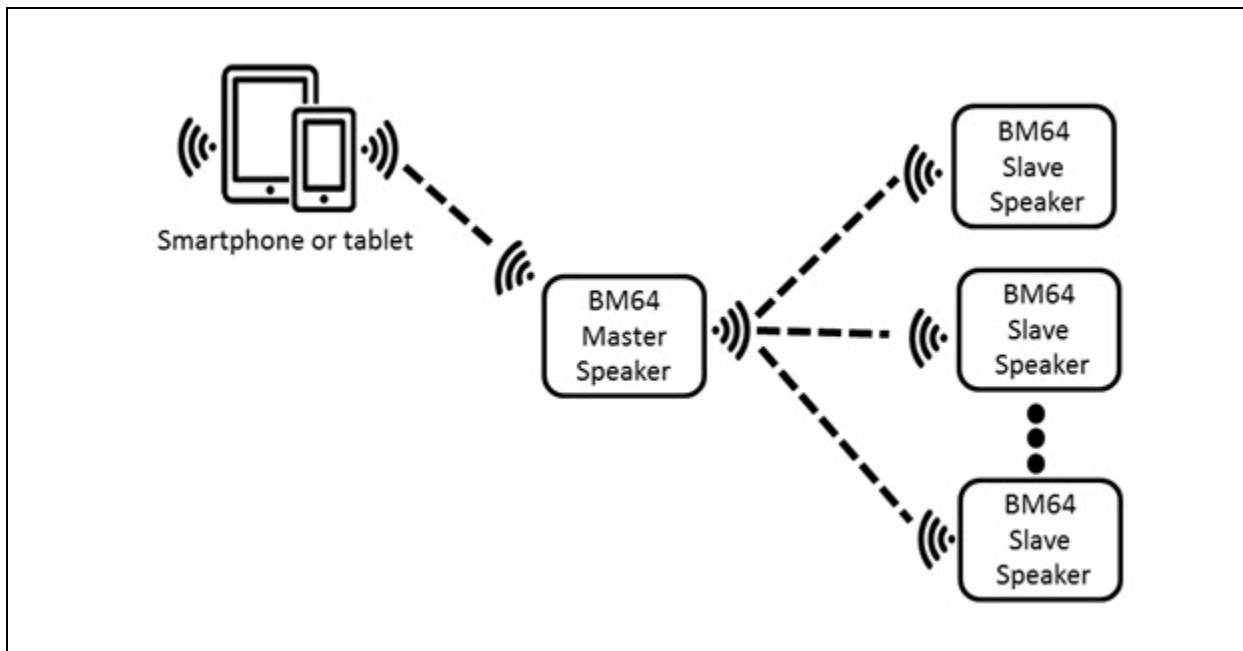

Figure 2 illustrates a typical Concert mode application where the master is connected to an audio streaming device through AUX-In.

FIGURE 2: CONCERT MODE: MASTER IS CONNECTED TO AUDIO STREAMING DEVICE THROUGH AUX-IN

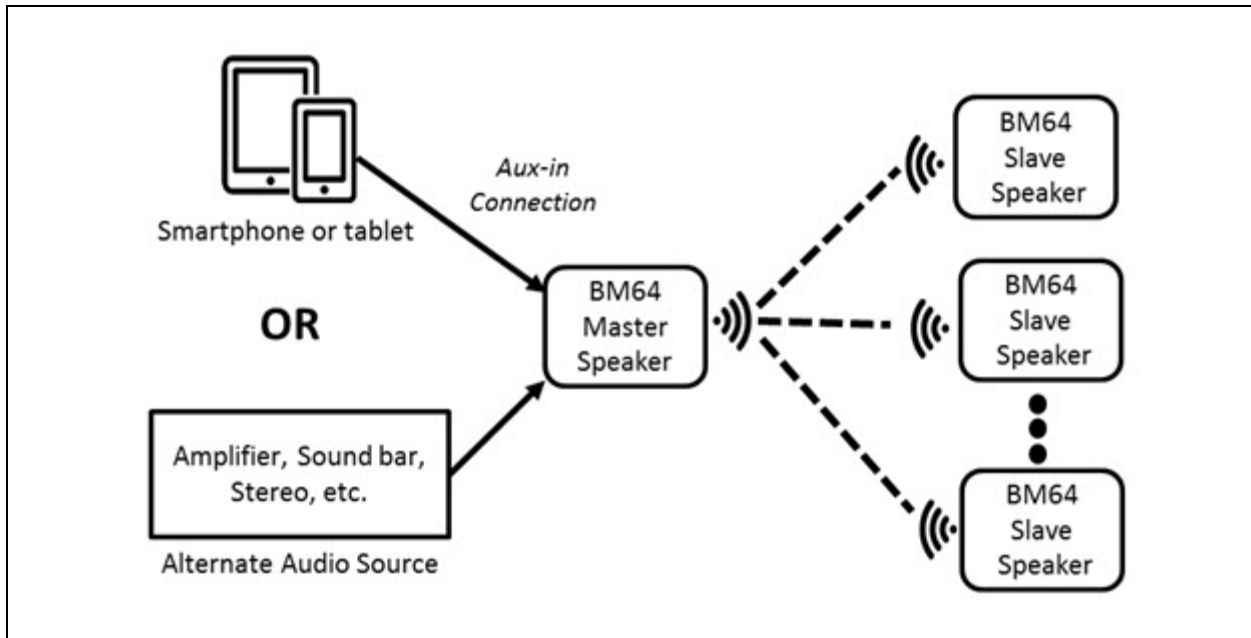

Figure 3 illustrates a typical Stereo mode application where the master is connected to an audio streaming device through Bluetooth.

FIGURE 3: STEREO MODE: MASTER IS CONNECTED TO AUDIO STREAMING DEVICE THROUGH BLUETOOTH

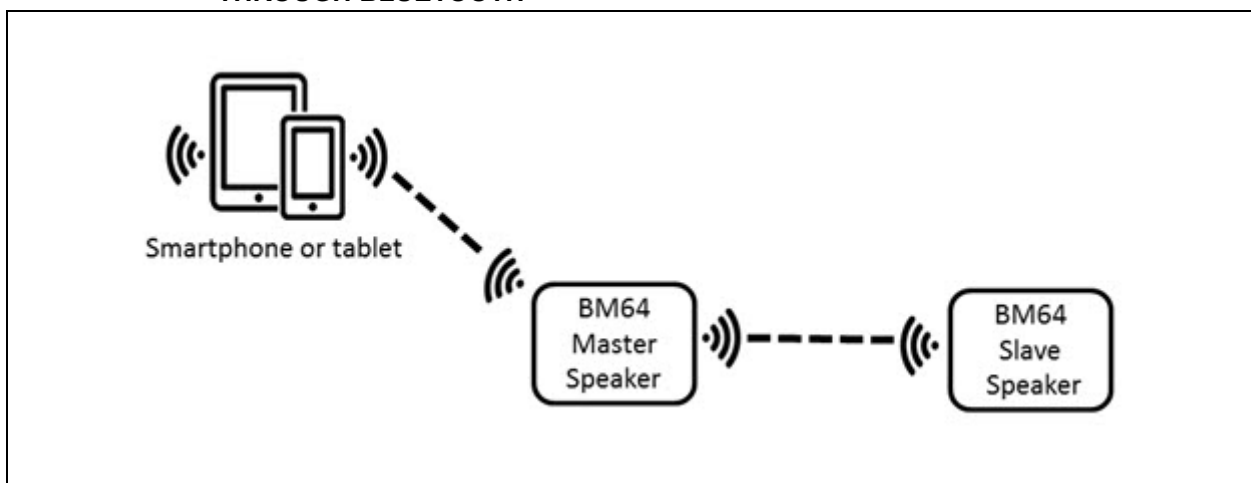
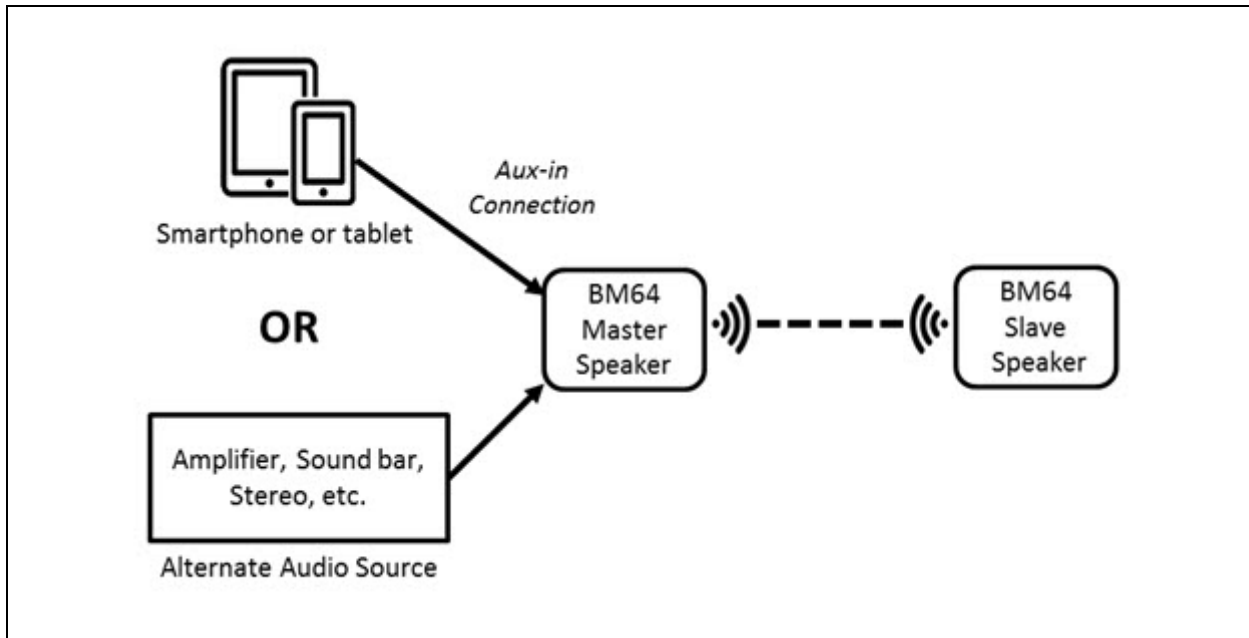

Figure 4 illustrates a typical Stereo mode application where the master is connected to an audio streaming device through AUX-In.

FIGURE 4: STEREO MODE: MASTER IS CONNECTED TO AUDIO STREAMING DEVICE THROUGH AUX-IN



There is no limit for the number of slave speakers which can connect to the master in Concert mode.

- Speakers which accepts L+/- and R+/- as input
- Android device 6.0 and higher

REQUIREMENTS

Documentation

- “*BM64 EVB User’s Guide*” (DS50002514)
- “*BM62/64 Bluetooth® 4.2 Stereo Audio Module Data Sheet*” (DS60001403)

Software

- Firmware: MSPK V1.xx
- MCU: PIC18 MSPK V1.x.x
- EEPROM Table: Customized EEPROM table (*.ipf)
- Microchip Bluetooth Audio (MBA) App v1.xx

Hardware

- BM64 EVB
- MCU Programmer: MPLAB REAL ICE™/ICD 3/PICKit™ 3
- 15V power supply
- Micro-USB cable
- Bluetooth-enabled audio device such as smartphone, tablet etc.
- AUX-In enabled audio streaming device

Tools

MSPK V1.xx package contains all the required tools.

DEMO SETUP

It is mandatory to program BM64 EVB with MSPK V1.xx software. If the BM64 EVB is not programmed with MSPK V1.xx software before the demo, follow the procedure from step 1 through step 5 to set up the demo. If EVB has previously been programmed with MSPK V1.xx then skip step 1.

1. Software Update

Update the firmware and MCU code from the MSPK V1.xx software package. For more information on firmware and MCU update procedure, refer to “*BM64 EVB User’s Guide*” (DS50002514), Section 3.6 and Section 3.7 respectively. To program the EEPROM, refer to Section 3.5 of “*BM64 EVB User’s Guide*” (DS50002514). Four EEPROM tables are provided in the package. If a customer has more than four devices or needs to customize the setting, then refer to [Appendix B: “Customizing UI and DSP Parameters”](#).

2. Connection

Connect a speaker to R/L+/- on the BM64 EVB. Only one speaker needs to be connected per EVB.

3. Power-up

Connect all the BM64 EVBs to 15 V supply and short press MFB on all the EVBs.

4. Installation

Install the Microchip Bluetooth Audio App on Android 6.0 or higher device. Refer to the procedure in [Appendix A: “Android App Installation”](#) to install the Android application.

Note: The Android version of the Microchip Bluetooth Audio App is available in the Google Play™ Store and the iOS version of the app is available in the Apple iTunes® store.

5. Provisioning

To provision multi-speaker into Concert/Stereo mode, a set of commands needs to be sent from MCU. These commands are sent either through pressing the button

on the BM64 EVB or through Microchip Bluetooth Audio App utilizing BLE UART Transparent mode command.

FUNCTIONALITY OF BUTTONS ON BM64 EVB

The BM64 EVB provides various button functionality:

- Short press MFB: To power-on/off BM64 EVB
- Long press MFB: To enter into Pairing mode
- Long press SW22: To enter into Master/Slave mode in Concert mode
- Short double press SW22: To add a new slave to the master
- Long press SW39: To enter into Master/Slave mode in Stereo mode
- Short press SW40: To toggle audio source between AUX-In and Bluetooth audio

Note: Long press is longer than 3 seconds and short press is shorter than 3 seconds.

Figure 5 illustrates the functionality of all the buttons available on the BM64 EVB.

FIGURE 5: BM64 EVB WITH VARIOUS BUTTON FUNCTIONALITY

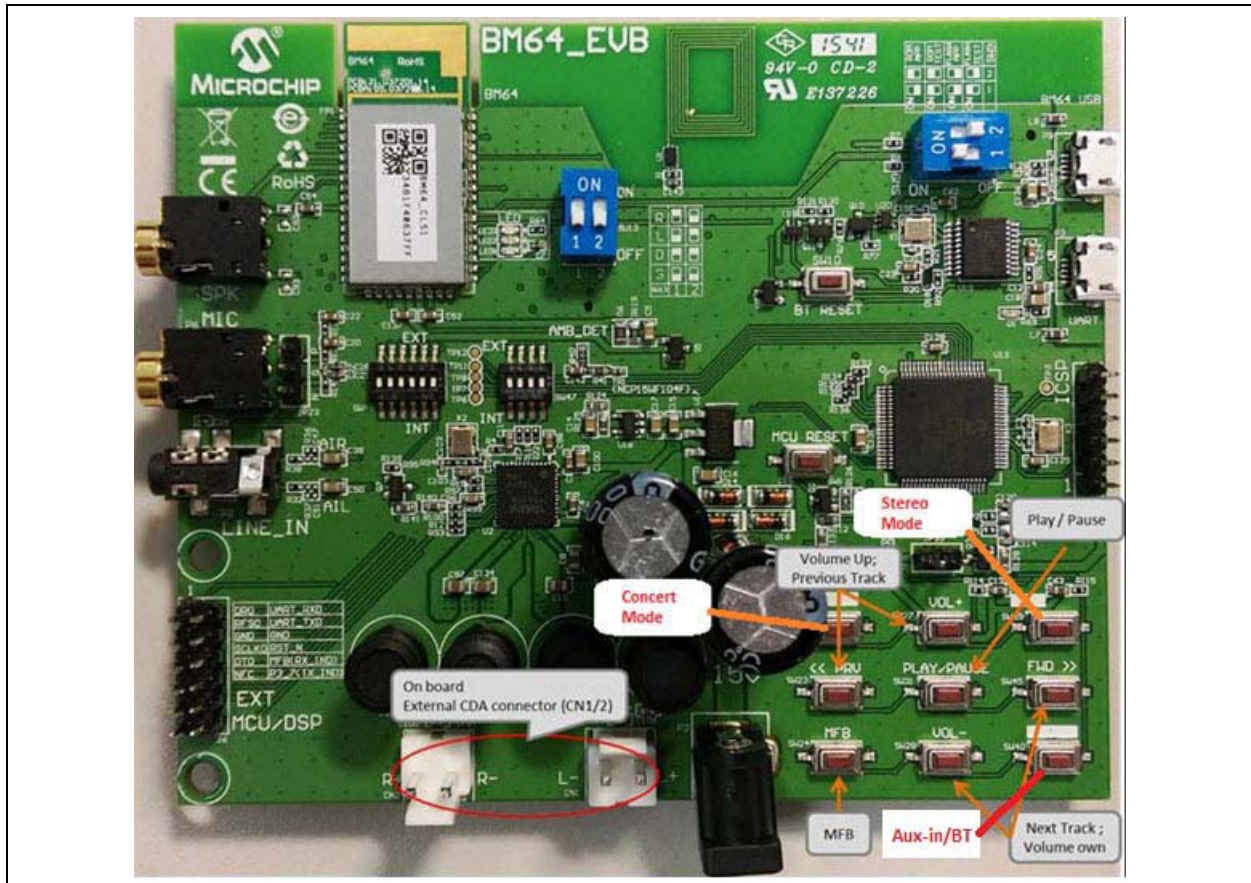

Concert Mode

Short press MFB on all the BM64 EVBs. This will power-on the EVB and initialization will be done. A flashing LED indicates that the BM64 EVB is powered up. A “power-on” voice prompt will also be played out. Long press SW22 on all EVBs. The EVB will have either solid red or blue LED flashing after a short time period. The EVB with solid red LED is connected as a slave to the EVB with a flashing blue LED as master. The EVB on which SW22 is pressed first is provisioned as master and others are provisioned as slave.

To connect the master with a Bluetooth streaming device, long press MFB on master (flashing blue LED on the EVB) to enter into Pairing mode. A “ready to pair” voice prompt is played out. Pair with Bluetooth-enabled audio streaming device. The “pairing completed” voice prompt will be played out after the pairing is completed with a Bluetooth-enabled device such as smartphone, tablet etc., and flashing blue LED will become solid blue on the EVB. Now play music on the audio streaming device. Music will be heard on master and slave speakers.

To add a new slave, short double press SW22 on the master and then long press SW22 on the new slave. The new slave will have solid red LED indicating that it is added in the group. Music will be heard on the newly added slave along with master and slave speakers.

To play the audio through AUX-In, connect the master (flashing/solid blue LED) with the audio streaming device through the AUX-In cable. Play music on the audio streaming device and the audio will be heard on both master and slave speakers. If Bluetooth audio was playing before inserting the AUX-In, it will pause the Bluetooth audio and AUX-In audio will start playing. Press SW40 on the EVB to toggle the audio source between AUX-In and Bluetooth. When the AUX-In cable is removed, the Bluetooth audio will resume in previous state.

A short press MFB on the master device will power-off master and connected slave devices.

Stereo Mode

Short press MFB on all BM64 EVBs. This will power-on the EVB and initialization will be done. A flashing LED indicates that the BM64 EVB is powered-up. A “power-on” voice prompt will also be played out. Long press SW39 on all EVBs. Initially red LED will flash on all EVBs. The EVB will have either solid red or flashing blue LED after some time period. The EVB with solid red LED is connected as a slave to the EVB with flashing blue LED as master. The EVB on which SW39 is pressed first is provisioned as master and the remaining are provisioned as slave.

To connect the master with Bluetooth streaming device, long press MFB on master (flashing blue LED) to enter into pairing mode. A “ready to pair” voice prompt will be played out. Pair with Bluetooth-enabled streaming

device, and a “pairing completed” voice prompt will be played out. In addition, a flashing blue LED will become solid blue on the EVB. Now play music on the audio streaming device. Music will be heard on master and slave speakers.

To play the audio through AUX-In, connect the master (flashing/solid blue LED) with the audio streaming device through AUX-In cable. Play music on audio streaming device, the audio will be heard on both master and slave speakers. If Bluetooth audio is playing before inserting the AUX-In, it will pause the Bluetooth audio and AUX-In audio will start playing. Press SW40 on the EVB to toggle the audio source between AUX-In and Bluetooth. When the AUX-In cable is removed, the Bluetooth audio will resume in its previous state.

A short press MFB on the master device will power-off the master and connected slave device.

CONCERT MODE PROVISIONING USING MICROCHIP BLUETOOTH AUDIO APP

1. Press MFB on all the BM64 EVBs. The Android app can also be used to power on individual BM64 EVB. For more details, refer to [Appendix D: “Android App Power Mode”](#).
2. Open Microchip Bluetooth Audio Android App on an Android phone. The following screen is displayed, see [Figure 6](#).

FIGURE 6: MICROCHIP BLUETOOTH AUDIO ANDROID APP

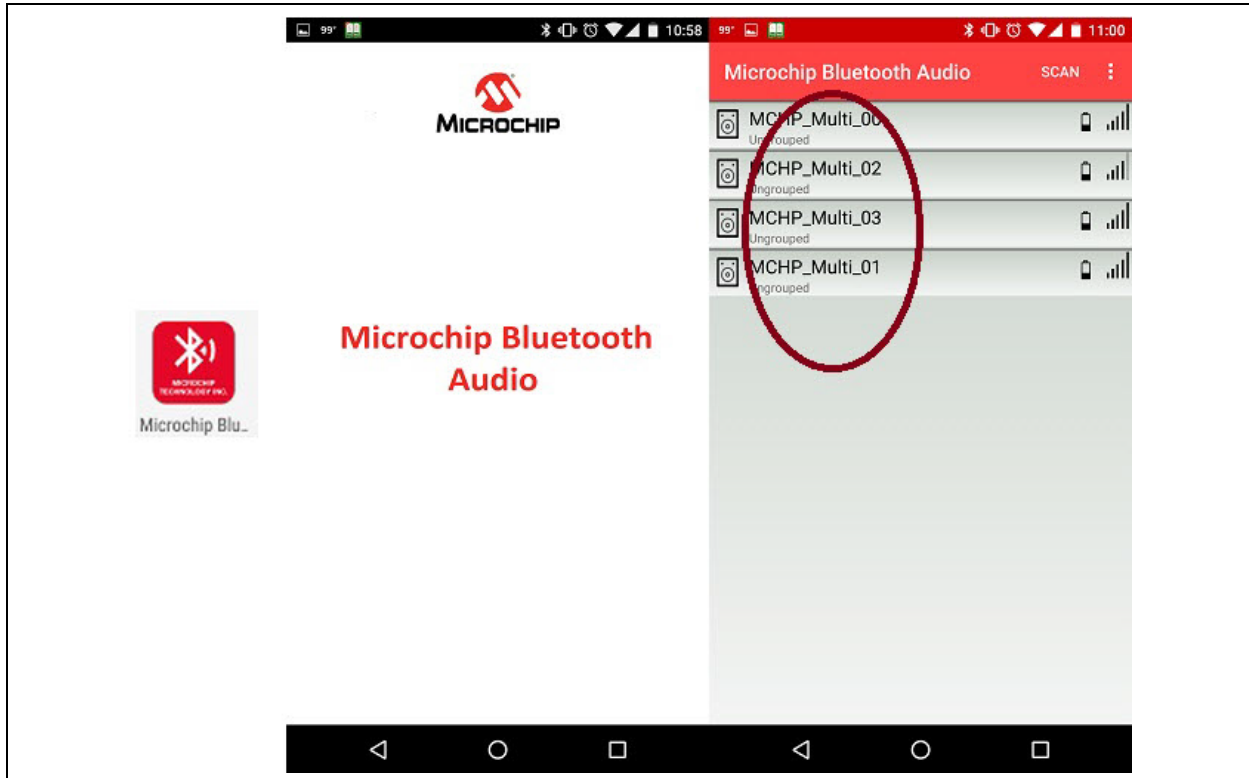

3. A list of connectable BLE devices is displayed. Select any one device **MCHP_Multi_x** (see [Figure 6](#)) and assign the role of master/slave. In

Concert mode, assign one as master and other as slaves. Select **Concert Slave** to assign one of the BM64 EVB as a slave, see [Figure 7](#).

FIGURE 7: SELECTING OPERATIONAL MODE

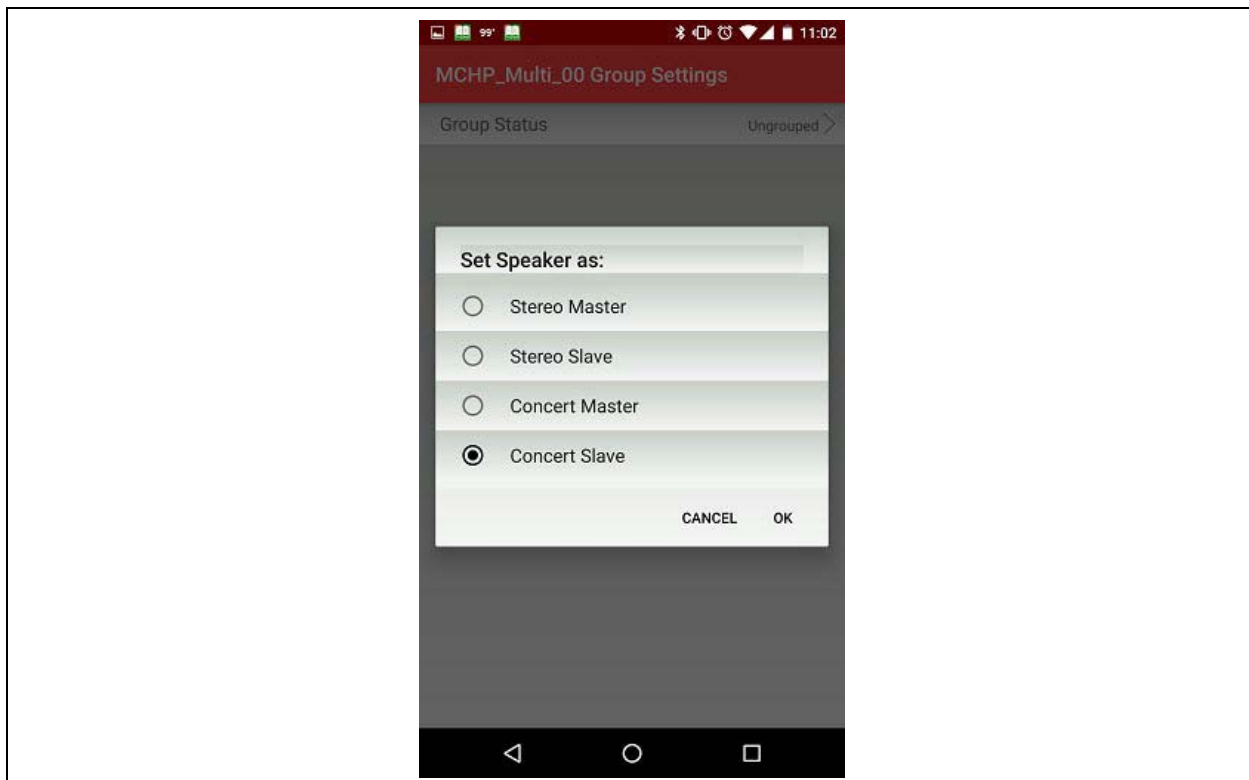

4. When the device is selected as a slave/master, “grouping” is displayed as **Group Status**, see [Figure 8](#). Then the red LED will start flashing on the BM64 EVB. Repeat this step for the other slave EVBs.

FIGURE 8: GROUPING SLAVE/MASTER

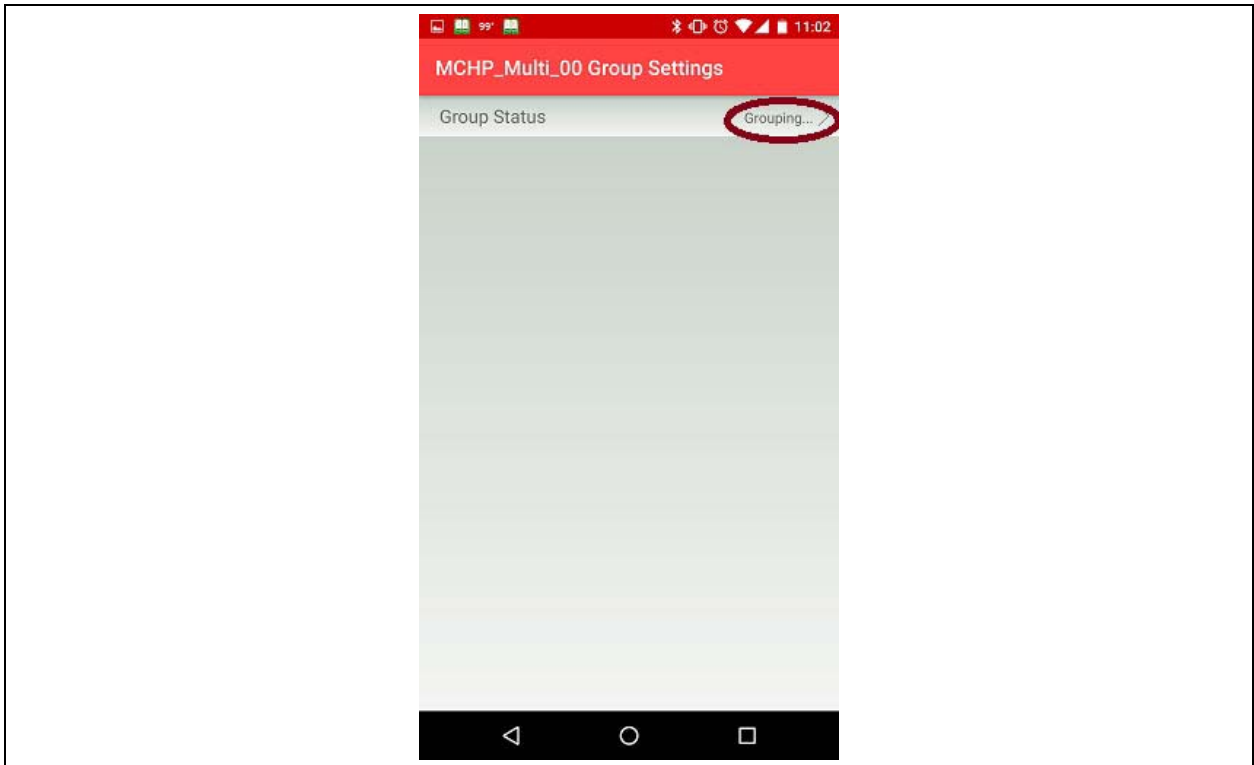

5. Select **Concert Master** to assign one of the BM64 EVB as a master, see [Figure 9](#).

FIGURE 9: SELECTING CONCERT MASTER

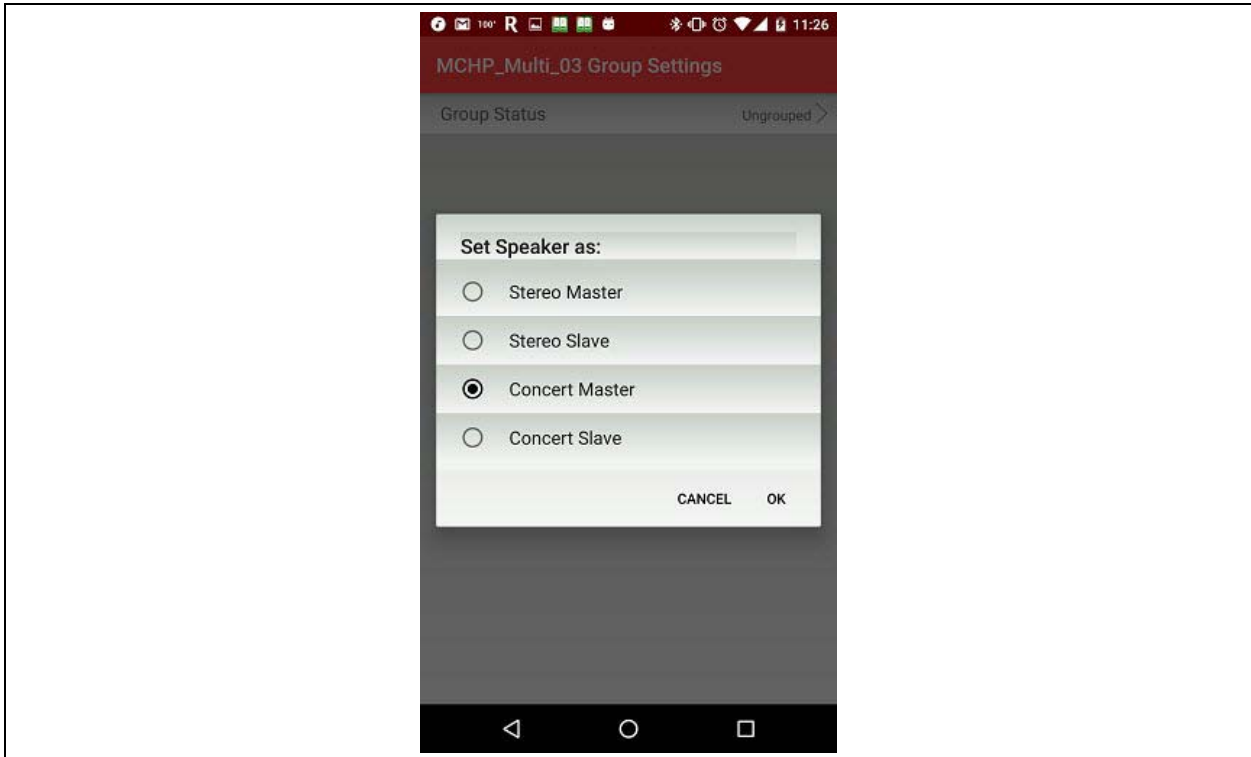

6. The red LED will flash on slave and will be connected to the master with the flashing blue LED. From the app select **Concert Master**, see

Figure 9. The "Concert Master" is assigned to a BM64 EVB, see Figure 10.

FIGURE 10: STATUS CONCERT MASTER

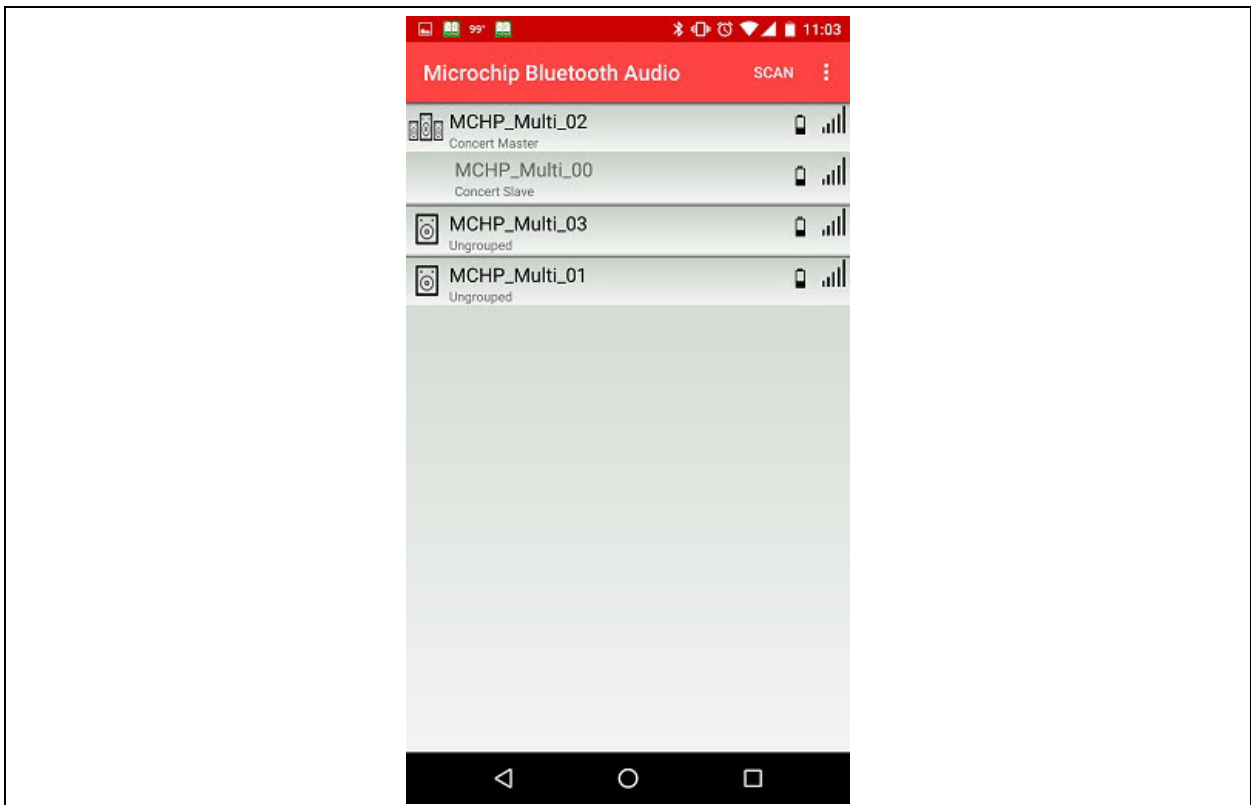

- From the app, click **Audio**, select **Pairing Mode Enter** to enter Pairing mode, see [Figure 11](#). A “ready to pair” voice prompt is played out on master BM64 EVB. Select **Speaker Connection Connect** and a list of discoverable Blue-

tooth devices will be displayed on the Android phone; select the device with name **MCHP_Multi_x** to pair and connect. A “device connected” voice prompt is played out the and flashing blue LED becomes solid blue.

FIGURE 11: AUDIO CONNECTION

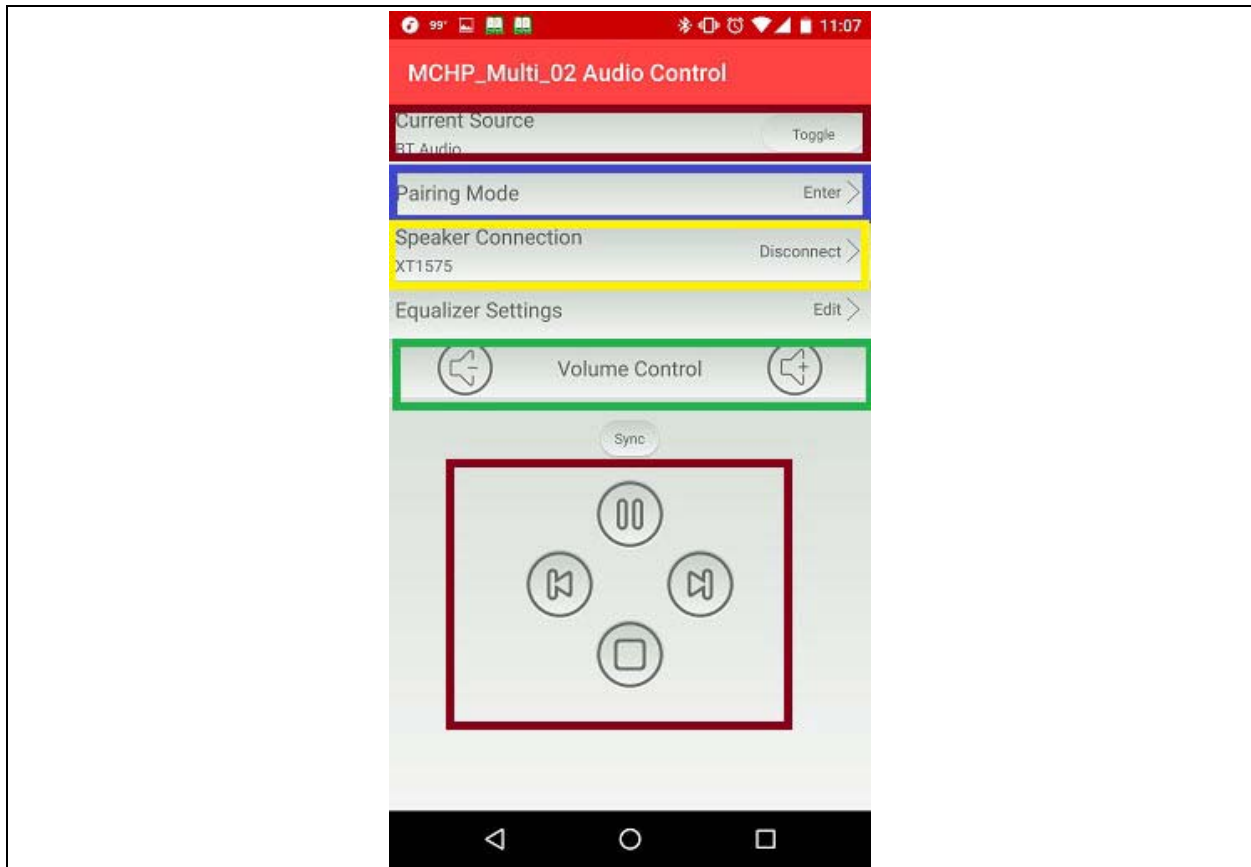

- Control the music from the app through **Music Control**, see [Figure 11](#). Click **Play**, and music will play on both master and slave speakers.
- For AUX-In mode, connect an audio streaming device with the master (solid/flashing blue LED) through audio AUX-In cable and play music. Music will play on both master and slave speakers.
- To toggle the audio source, click the **Toggle** button on the app, as illustrated in [Figure 12](#).

FIGURE 12: TOGGLE AUDIO SOURCE

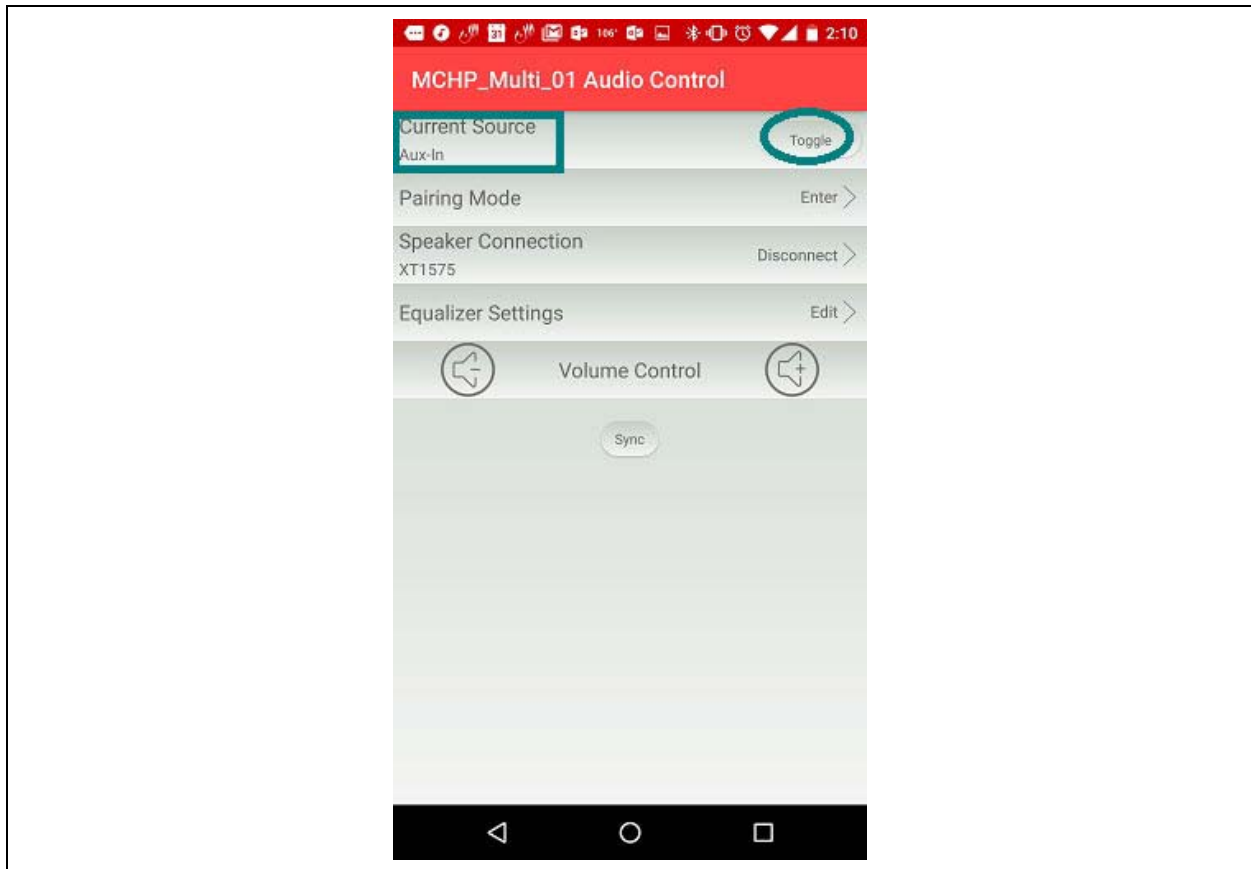

ADDING A NEW SLAVE

1. From the app pause the music play. Click the **Setting** tab, select **Concert Master**. A small window will pop up, select **Add new slave** to add a new slave, see [Figure 13](#).

FIGURE 13: ADDING A NEW SLAVE

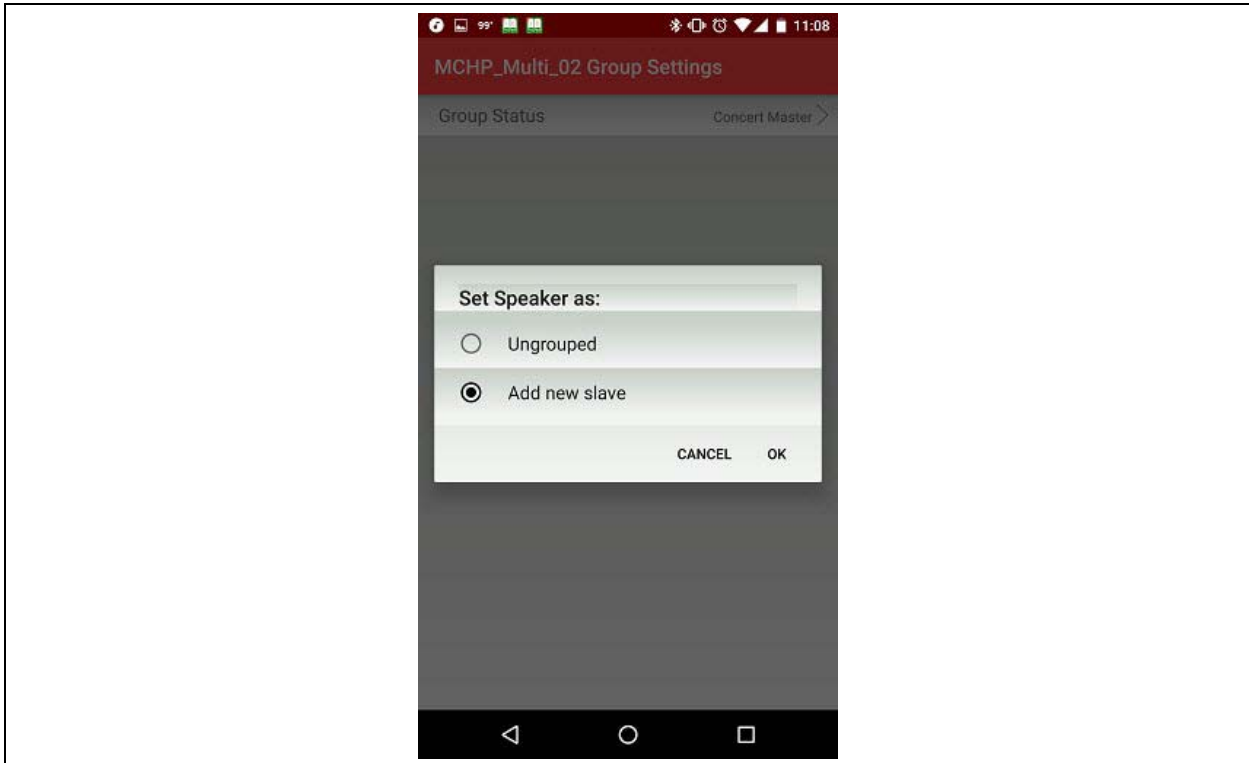

2. Go to Scan mode and click **Scan**. “Waiting for new slave” displays, see [Figure 14](#). Select **Concert Slave** to add as a slave.

FIGURE 14: SCANNING FOR NEW SLAVE

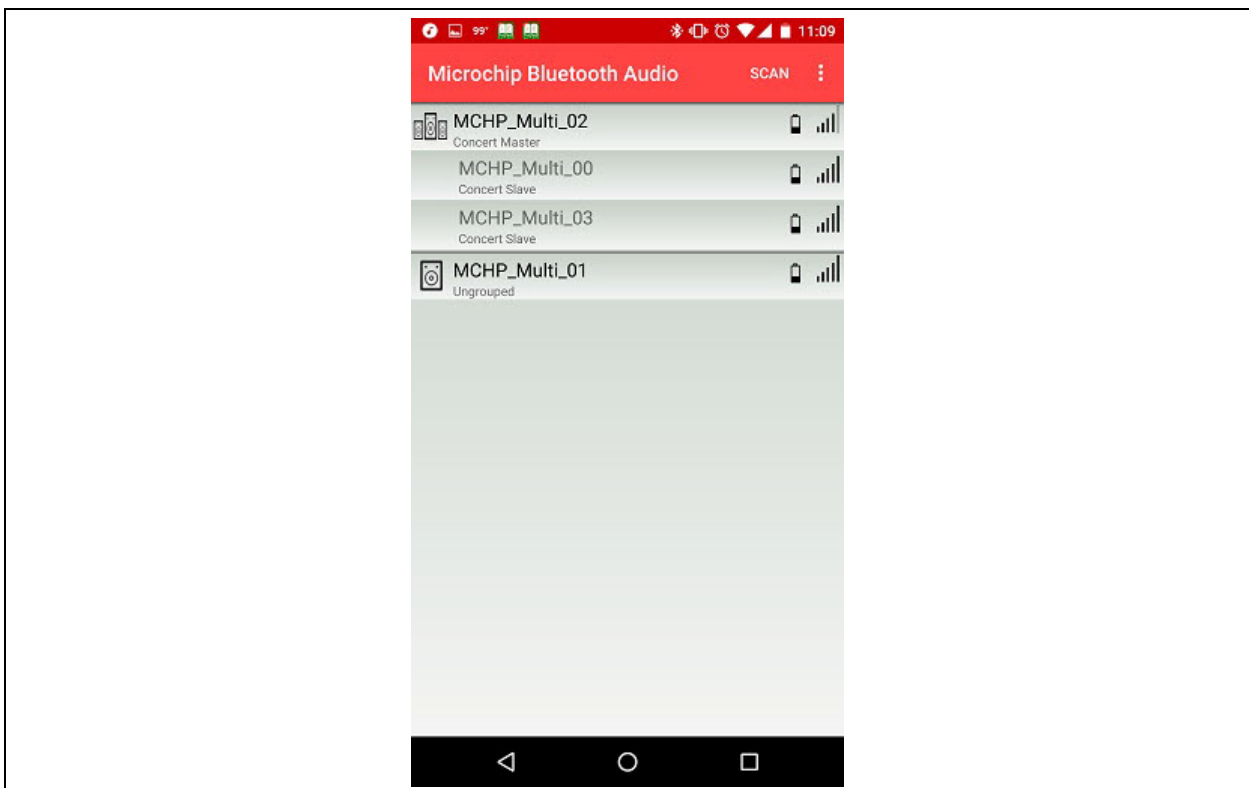

3. New slave is added to the master. Click **Scan** and select **Concert Master**. Play music from the **Audio** tab (see [Figure 11](#)). Music will be heard on master and slave including newly added slave.

STEREO MODE PROVISIONING USING MICROCHIP BLUETOOTH AUDIO ANDROID APP

1. In Stereo mode two speakers are used, one as master and another as slave. Stereo mode provisioning through the Microchip Bluetooth Audio Android App is similar to Concert mode provisioning. Select **Stereo Master** and **Stereo Slave** from the app, see [Figure 15](#), in place of Concert mode master and Concert mode slave in step 1 through step 8 (“**Concert**

Mode Provisioning Using Microchip Bluetooth Audio App”). Slave will have a solid red LED and master will have flashing/solid blue LED.

2. For AUX-In audio, connect master (solid/flashing blue LED) with audio streaming device through AUX-In cable.
3. The AUX-In and the Bluetooth source can be toggled from the app toggle button, as illustrated in [Figure 11](#).

Note: It is not mandatory that the Bluetooth streaming device and provisioning device be the same. Instead, one Android/iOS device can be used for provisioning and another Bluetooth audio device for music play. Provisioning is done through BLE.

FIGURE 15: PROVISIONING STEREO MODE

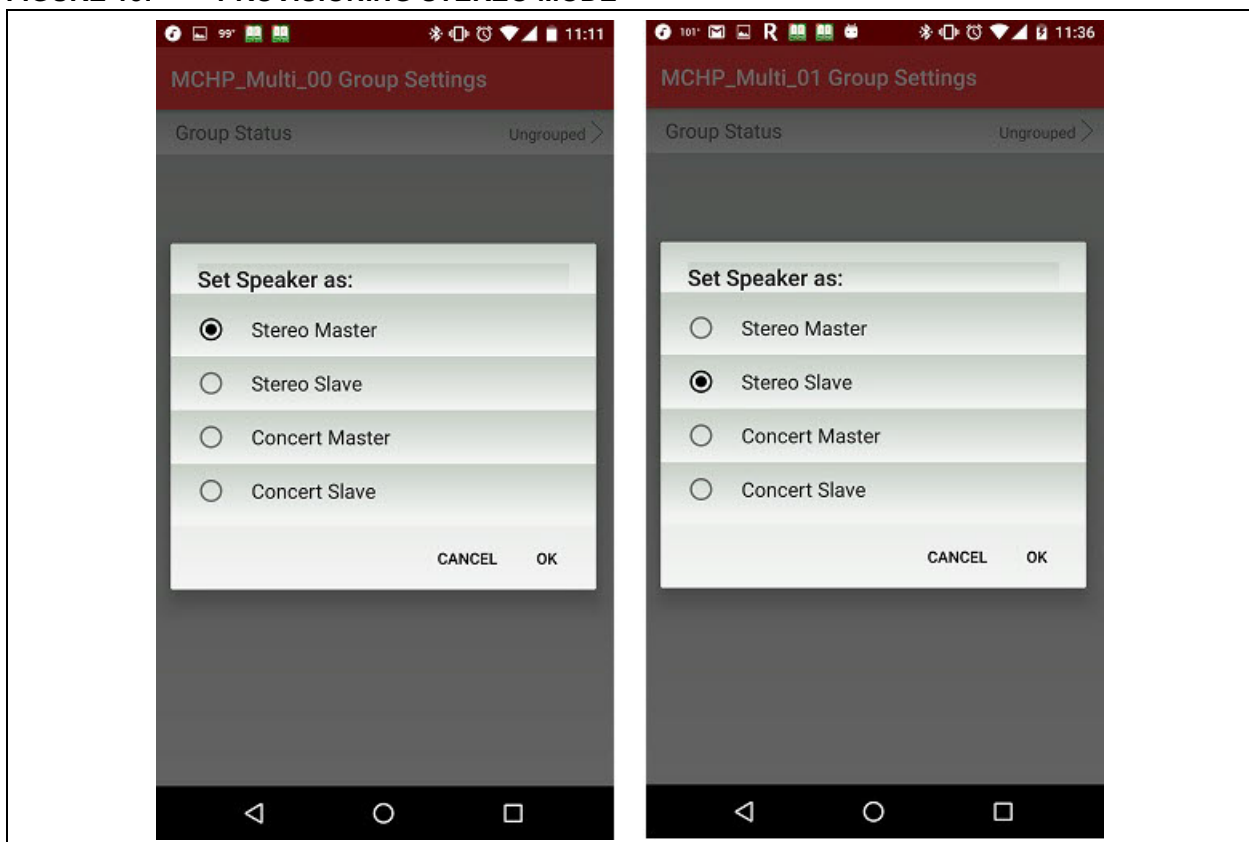

QUICK MASTER/SLAVE SETUP

The Microchip Bluetooth Audio App has added a new feature to establish quick master and slave speakers.

1. From the Microchip Bluetooth Audio App, click **Settings**, as illustrated in [Figure 16](#).

FIGURE 16: QUICK MASTER/SLAVE SETUP

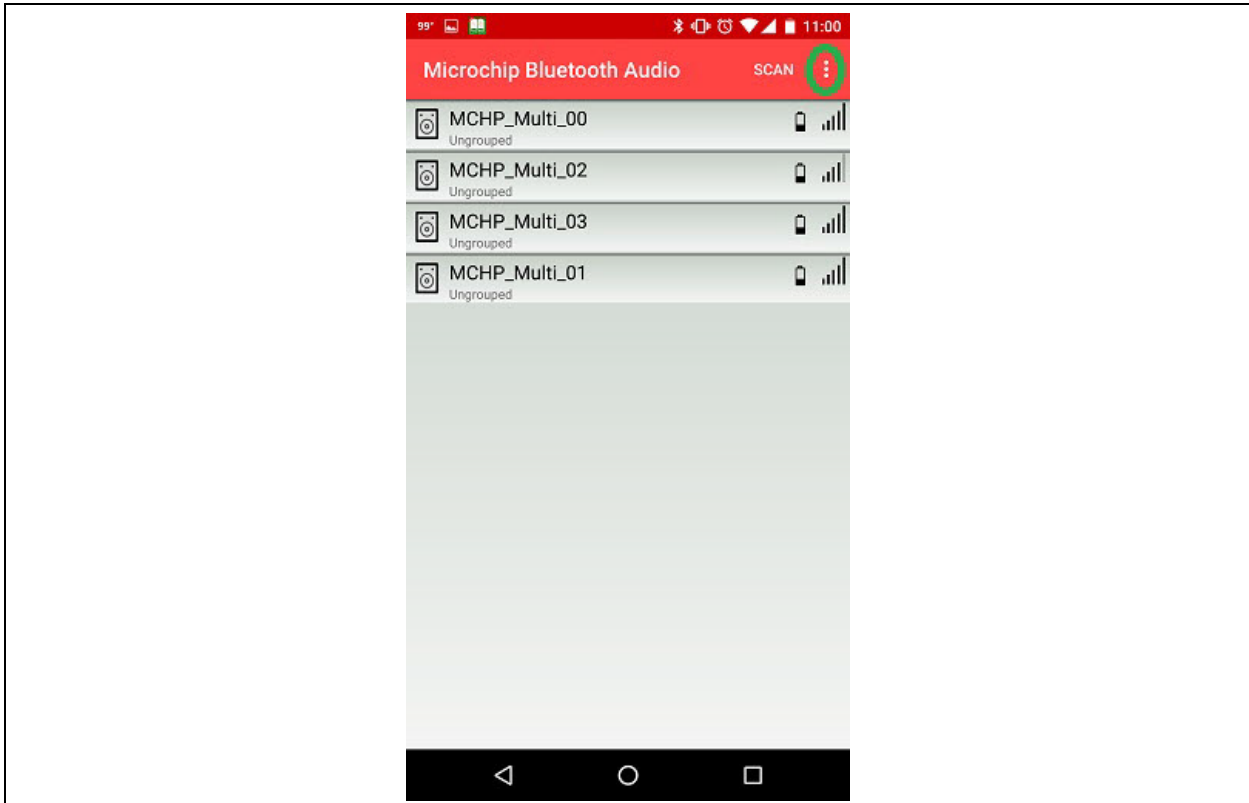

2. Select **Create Personal Group**, as illustrated in [Figure 17](#).

FIGURE 17: CREATING PERSONAL GROUP

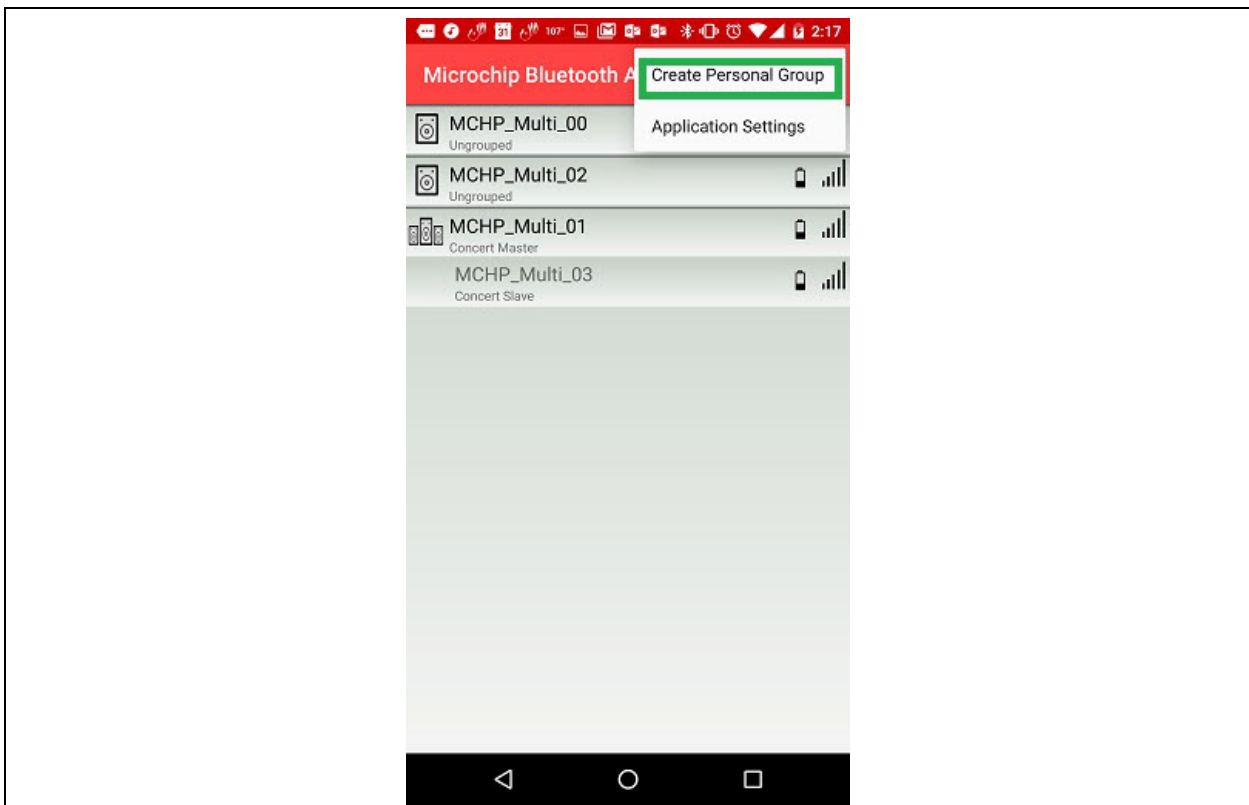

3. Select **Stereo/Concert** mode from the pop-up window, as illustrated in [Figure 18](#).

FIGURE 18: SELECTING STEREO/CONCERT MODE

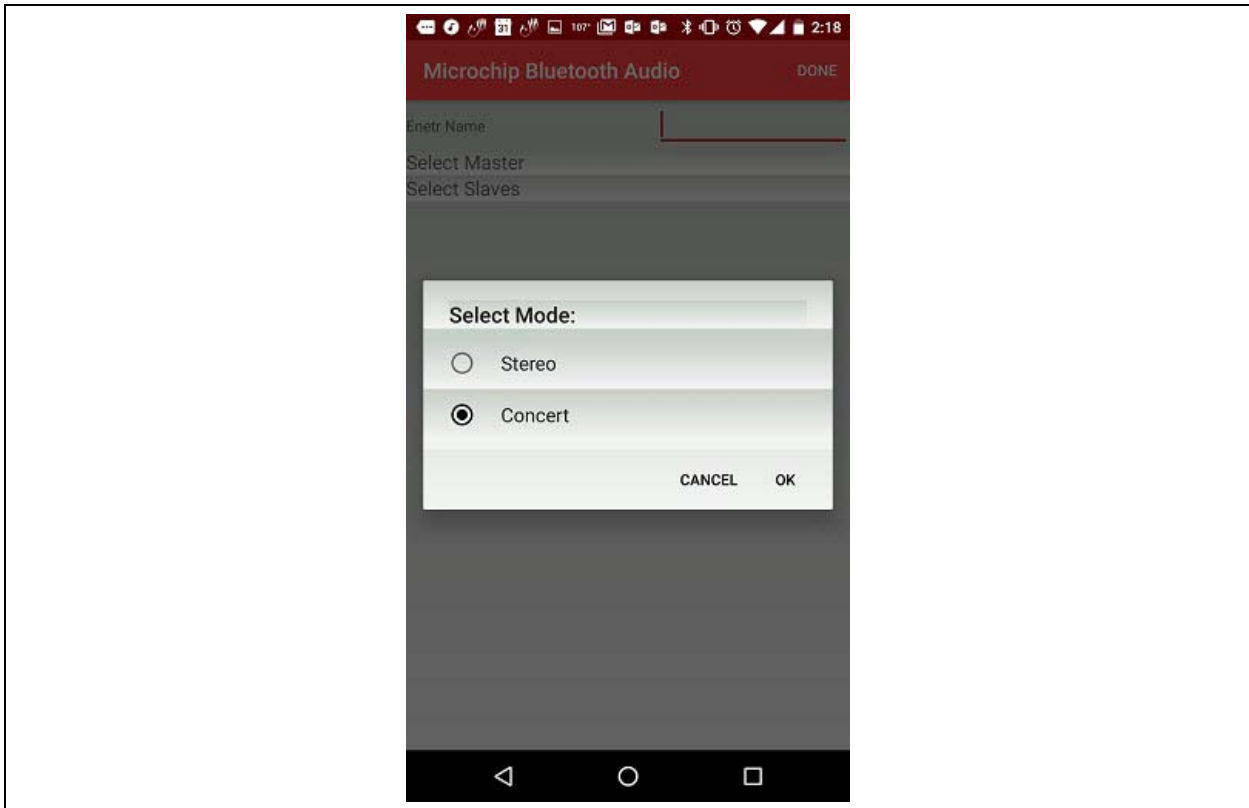

4. After selecting the mode, the Personal Audio group page is displayed. Enter name (any user-defined) and select master and slave speakers, as illustrated in [Figure 19](#).

FIGURE 19: PERSONAL AUDIO GROUP SETTINGS

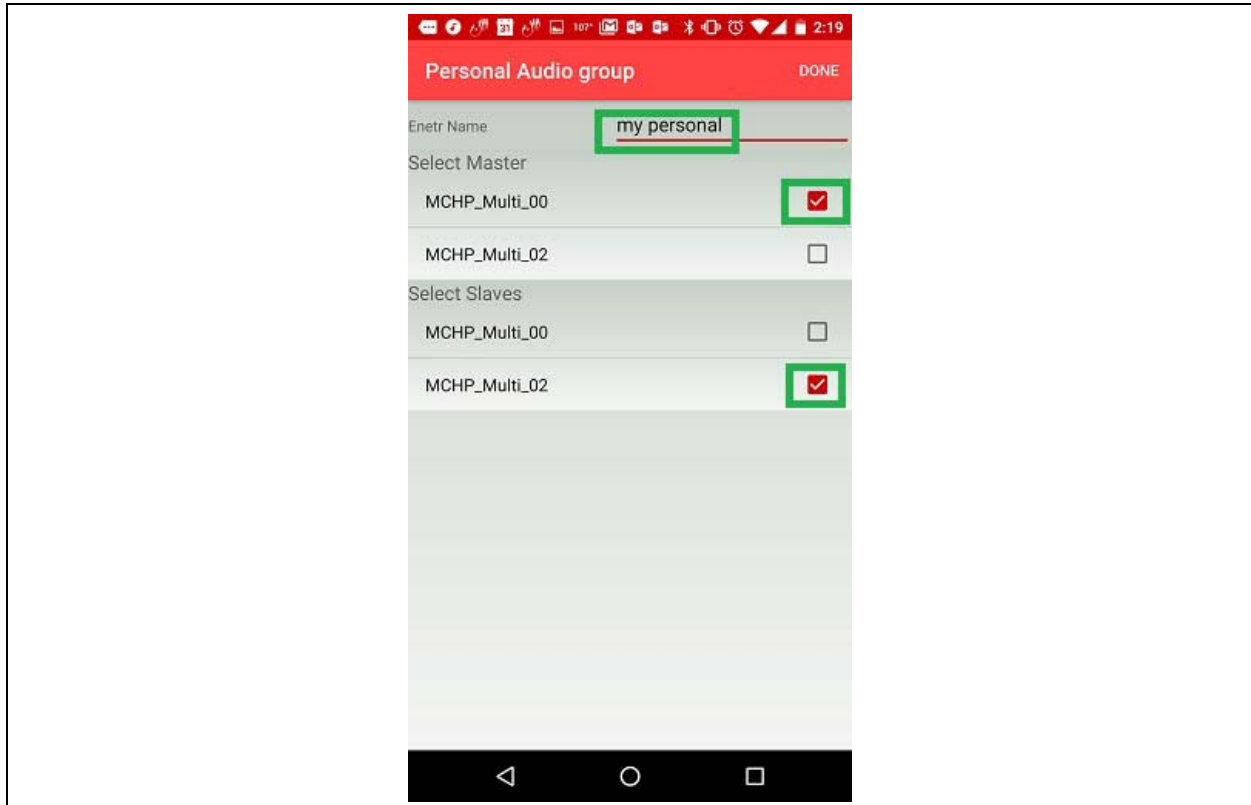

5. Master and slave speakers will be created. To play music, follow step 7 through step 10 from [“Concert Mode Provisioning Using Microchip Bluetooth Audio App”](#).

RENAMING SPEAKER

The speaker name can be changed through the app, as illustrated in [Figure 20](#). The change in speaker name is permanent, i.e. upon power cycle the new speaker name is retained.

FIGURE 20: RENAMING SPEAKER

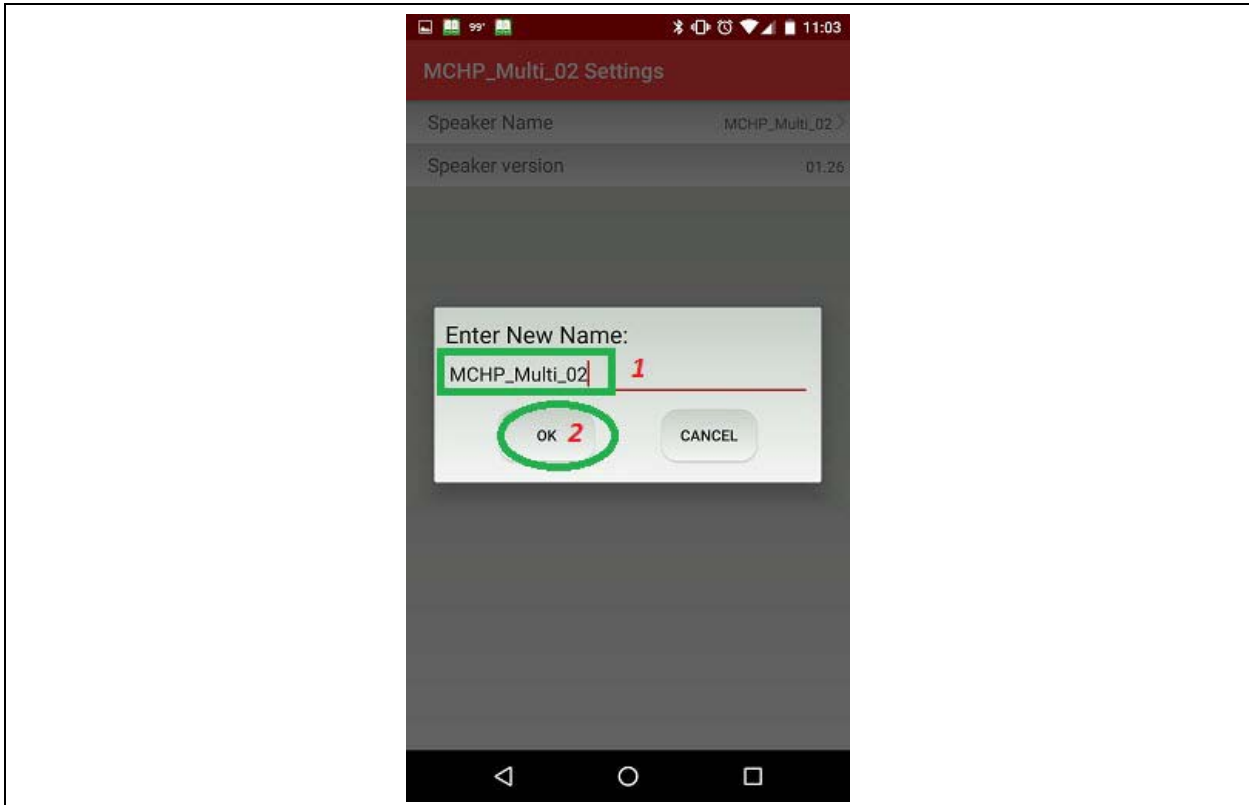

EQUALIZER SETTING

The equalizer parameters can be set/changed from the Microchip Bluetooth Audio App.

1. Select **Equalizer Settings** > **Edit** to edit the equalizer parameters, as illustrated in [Figure 21](#).

FIGURE 21: EDITING EQUALIZER SETTINGS

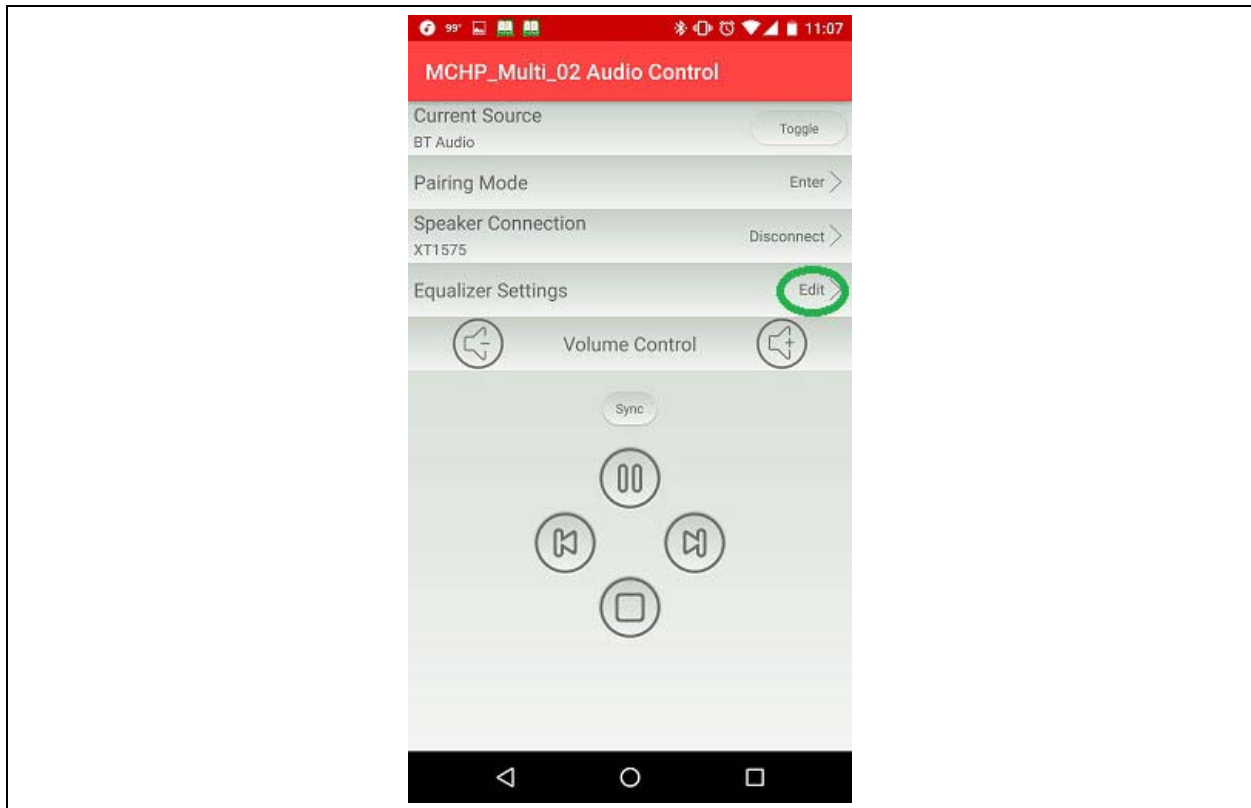

2. Select the standard equalizer parameters from the list, as illustrated in [Figure 22](#).

FIGURE 22: STANDARD EQUALIZER PARAMETERS LIST

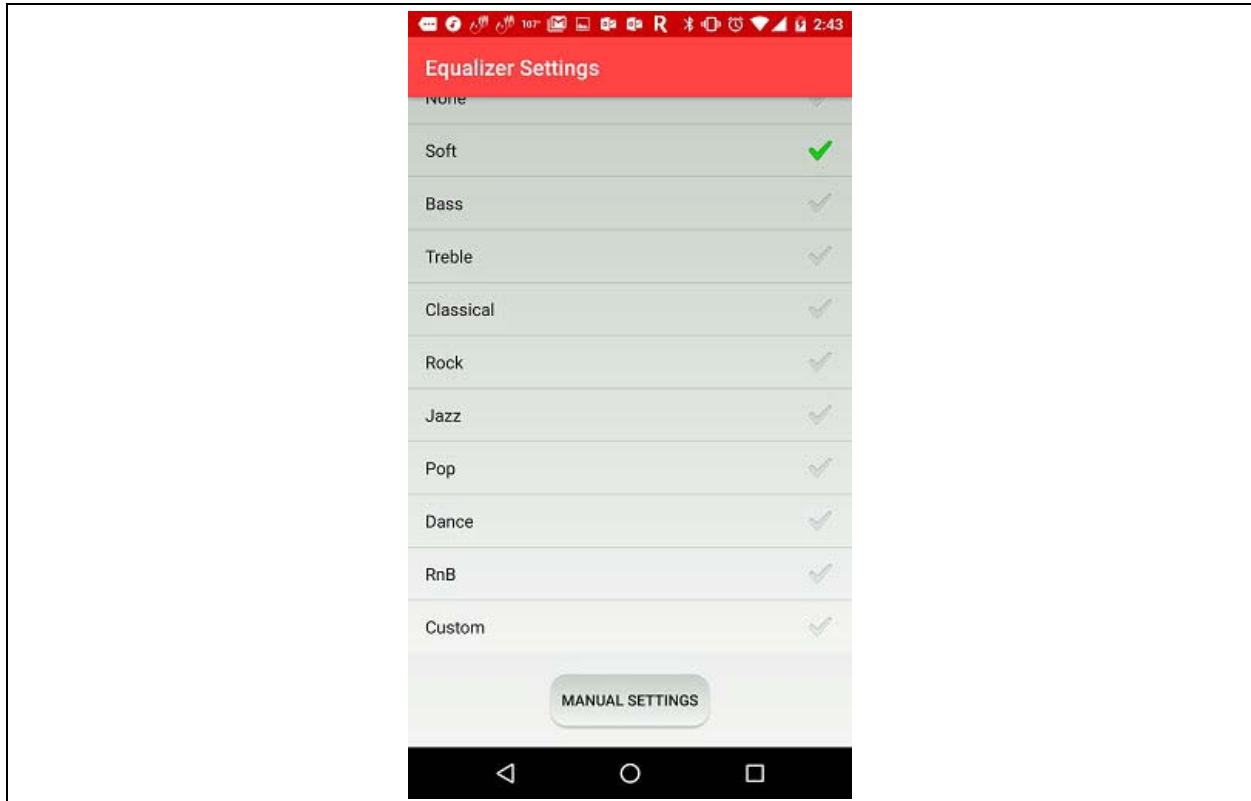

3. Select **Manual Settings** to set the equalizer parameters manually, as illustrated in [Figure 23](#).

FIGURE 23: MANUAL SETTINGS OF EQUALIZER PARAMETERS

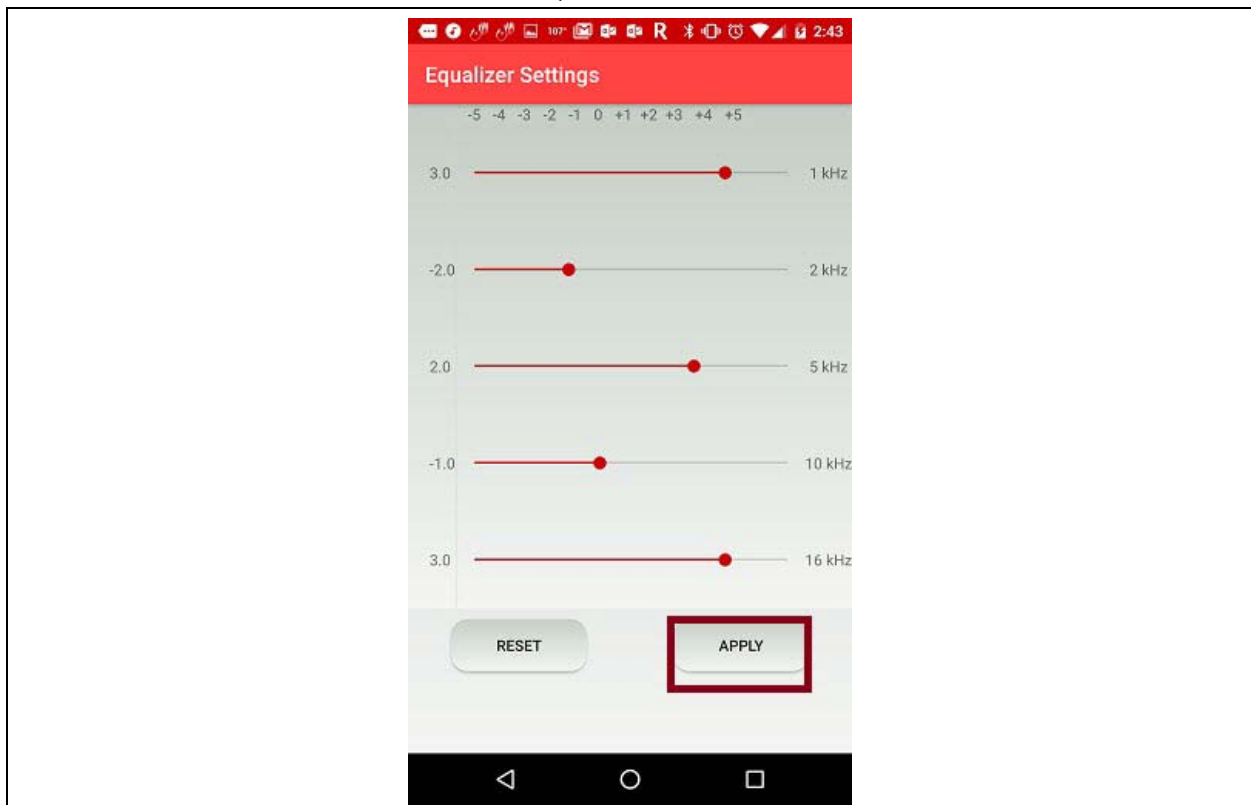

COMMAND PROMPT FEATURE

The Microchip Bluetooth Audio App provides a command prompt feature. Any command can be sent from this command prompt to a connected BM64

device as illustrated in [Figure 24](#). This feature is used to test the customized command such as lighting control, volume control of particular speaker, zone information extraction and reprogramming, etc.

FIGURE 24: COMMAND PROMPT

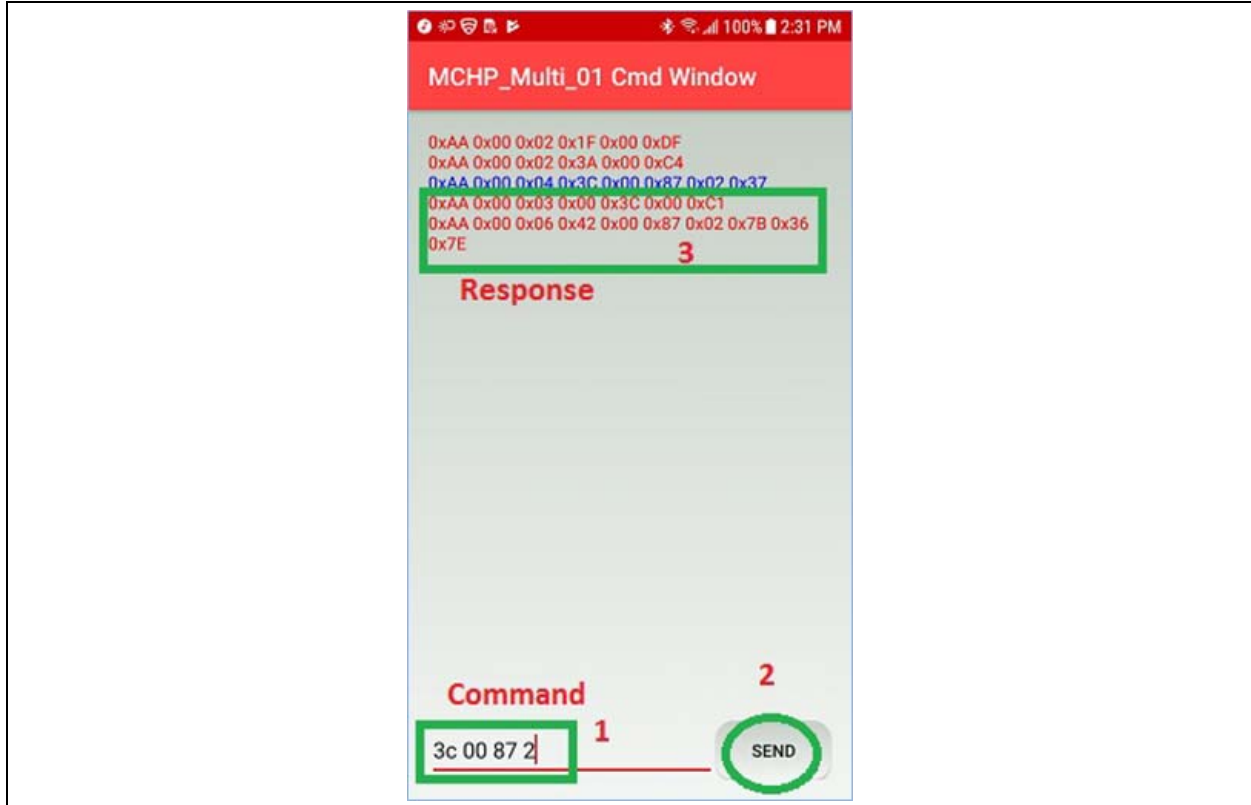

FIRMWARE CAPABILITIES/ FEATURES

The following features are supported in the multi-speaker V1.xx firmware:

Concert Mode

In Concert mode three or more speakers are used. One speaker works as master and rest as slaves, connected to the master through Bluetooth. The master is connected to a Bluetooth-enabled streaming device through Bluetooth (such as smartphone) or to an AUX-In cable. [Figure 1](#) and [Figure 2](#) illustrate a typical Concert mode application. The audio packets are SBC encoded with medium quality setting and audio packet is not ACKed by slave. There is no feedback mechanism between slaves and the master. The button press on the master is communicated to the slave, but the button press on the slave affects only the slave speaker on which the button is pressed. The AUX-In audio is SBC-encoded with medium quality settings by the master. It follows the same procedure of transmission as a Bluetooth packet received by the master. The AUX-In audio to a slave speaker plays on the slave speaker only. It is not transmitted to the master speaker.

Stereo Mode

In Stereo mode two speakers are used. One speaker works as a master and another as a slave connected to the master through Bluetooth. The master speaker is connected to a Bluetooth-enabled streaming device through Bluetooth or through AUX-In cable to an audio streaming device. [Figure 3](#) and [Figure 4](#) illustrate a typical Stereo mode application. The audio packets are SBC-encoded with a high quality setting and every packet is ACKed by slave. The lost packet or NACKed packet is re-transmitted by the master. The button press is synchronized on both the master and slave i.e. play, pause, volume, up/down button press on master and slave speaker has similar effect. The AUX-In audio is SBC-encoded with high quality settings by master. It follows the same procedure of transmission as the Bluetooth packet received by the master. The AUX-In audio on slave speaker plays on the slave speaker and is not transmitted to the master speaker. The auto-reconnect feature has been enabled in stereo mode; i.e., upon the power cycle of master and slave, they reconnect.

Zone/Group

The concept of a zone or group applies when one group of speakers cannot connect with another group of speakers in a multi-speaker system. There is one master speaker and multiple slave speakers in a group. Each group is identified by 2 bytes unique ID. This

unique ID can be programmed into a set of speakers to make them into a group. Many such groups can co-exist without interfering with one another.

Note 1: EEPROM address 0x87 and 0x88 is reserved for storing unique ID. A new UART command has been added to program group ID.

Simultaneous Bluetooth and AUX-In Audio

Both Concert mode and Stereo mode support simultaneous Bluetooth audio and AUX-In audio. The audio source can be toggled by short pressing SW40 on the EVB. This functionality is also available on the Microchip Bluetooth Audio App, see [Figure 12](#).

Programmable AVRCP Version

Audio/Video Remote Control Profile (AVRCP) version can be programmed to v1.6/v1.3. For more details, refer to [Appendix E: “AVRCP Version”](#).

AAC Codec

AAC codec has been enabled. To enable Advanced Audio Coding (AAC) codec, refer to [Appendix F: “AAC Codec”](#). The AAC codec is preferred for iOS devices.

Programmable AUX-In Latency

The AUX-In latency can be programmed from 20 ms to 80 ms. For more details, refer to [Appendix G: “Programming AUX-In Latency”](#).

Auto Reconnect

The Concert/Stereo modes support the auto-reconnect feature i.e. upon power cycle master and slave reconnects.

Voice Prompt and Hands Free Profile

Voice prompt and HFP are mono by default and can be enabled in Stereo mode (L and R channel). Refer to [C.1 “Selecting UI Parameters”](#).

MCU AND CODEC

The MSPK V1.xx code is developed and tested on the BM64 EVB. The BM64 EVB contains the BM64 module, PIC18 MCU and a Yamaha DSP. However, PIC18 and Yamaha DSP can be replaced by another MCU and codec, but the BM6x module is mandatory.

Note: 44.1K to 48K Audio SRC(ASRC) and 8/16K to 48K Voice SRC(VSRC) are supported in MSPK v1.1. Therefore, any Codec/Class D amplifier can be used. ASRC and VSRC can be selected in UI, refer to [C.1 “Selecting UI Parameters”](#).

MCU and BM64 communication

The MCU communicates with the BM64 module through UART. A minimum set of hardware connections is required to interface MCU to the BM64 module. [Figure 25](#) illustrates the minimum connections required by the relevant hardware pins on the BM64 module.

FIGURE 25: MCU AND BM64 EVB INTERFACE

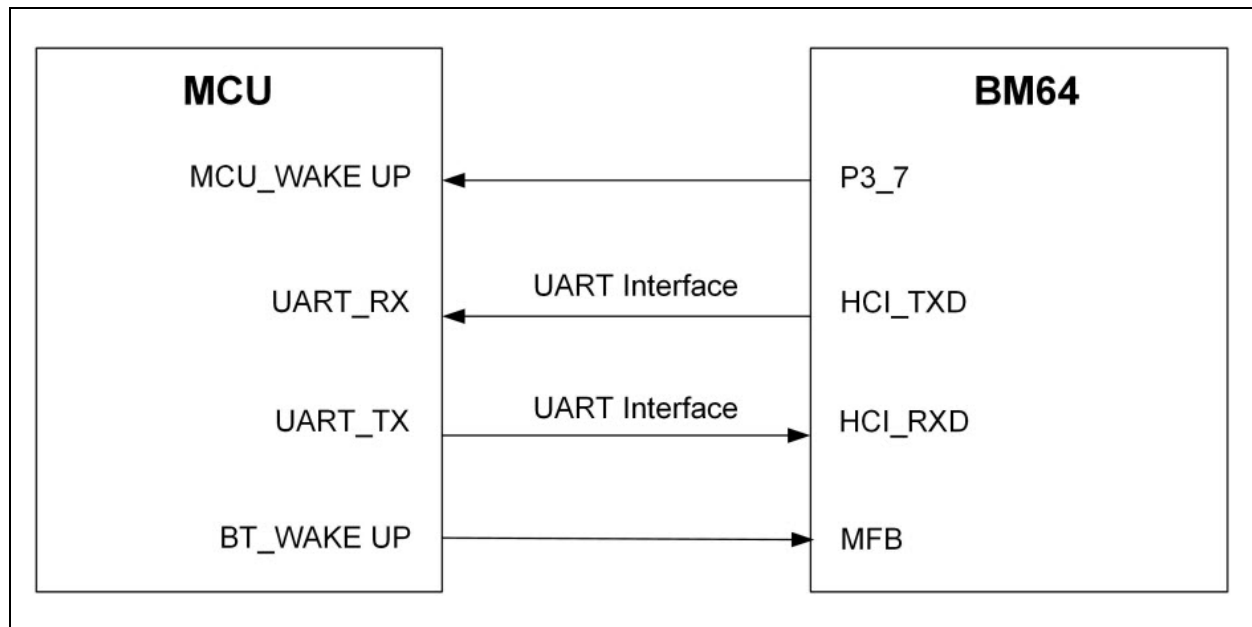

MCU Commands

MCU communicates with the BM64 module through UART commands. A summary of the commands is provided in “AudioUARTCommandSet_Summary_table_V2.0x.xlsx” and details of the commands are provided in “AudioUARTCommandSet_v2_0x.docx”. Both the documents are part of the MSPK V1.xx software package.

PACKAGE CONTENTS

The MSPK V1.xx package contains the following:

1. MSPK Firmware V1.xx(.hex file only)
2. Sample EEPROM table (*.ipf files), UI file (.txt) and DSP file (.txt)
3. PIC18 MCU code (binary and source code)
4. Microchip Bluetooth Audio Android/iOS App and their source code
5. Documentation

- Application Note
- AudioUARTCommandSet_v2_0x.docx
- AudioUARTCommandSet_Summary_table_V2.0x.xlsx
- Release Note
- 6. Tools
 - UI Tool
 - DSP Tool
 - isupdate
 - EEPROM Tool
 - UART Command Set Tool
 - MP Tool

MULTI-SPEAKER USER APPLICATION

- Museum guided tour
- Restaurant
- Outdoor entertainment

- In-home entertainment
- Retail shops
- Latency between audio device connected through AUX-In to the master is programmable between 20 ms to 80 ms

PERFORMANCE METRICS

Latency

- Latency between master and slave speakers is in sub millisecond (<0.3 ms) range
- Latency between Bluetooth streaming device and master is up to 240 ms

Range

The customer can choose Class 1 or Class 2 based upon the end application. [Table 1](#) provides the BM64 module Class 1 and Class 2 part numbers.

TABLE 1: BM64 MODULE CLASS 1 AND CLASS 2 PART NUMBERS

Part No	Description
BM64SPKA1MC1-0001AA	Bluetooth 4.2 Stereo Audio module with BLE, I ² S, Flash, Class 1 without RF shield, built-in antenna
BM64SPKS1MC1-0001AA	Bluetooth 4.2 Stereo Audio module with BLE, I ² S, Flash, Class 1 with RF shield, built-in antenna
BM64SPKS1MC2-0001AA	Bluetooth 4.2 Stereo Audio module with BLE, I ² S, Flash, Class 2 with RF shield, built-in antenna
BM64SPKA1MC2-0001AA	Bluetooth 4.2 Stereo Audio module with BLE, I ² S, Flash, Class 2 without RF shield, built-in antenna

Power Consumption

The Advanced Audio Distribution Profile (A2DP) streaming consumes up to 13 mA. Since the master is re-transmitting and SBC encoding for AUX-In audio, power consumption is doubled; i.e., up to 25 mA. The BLE Beacon consumes between 1.6 mA to 1.99 mA depending upon transmission interval and packet size.

APPENDIX A: ANDROID APP INSTALLATION

To install the application, perform the following steps:

1. Connect the Android phone to the computer

using a mini-B USB connector.

Note: The latest Android version (Android 6.0 and higher) does not show any directory in the phone. Enable “Transfer files” from the phone to access phone memory, as illustrated in [Figure 26](#).

FIGURE 26: USB TRANSFER

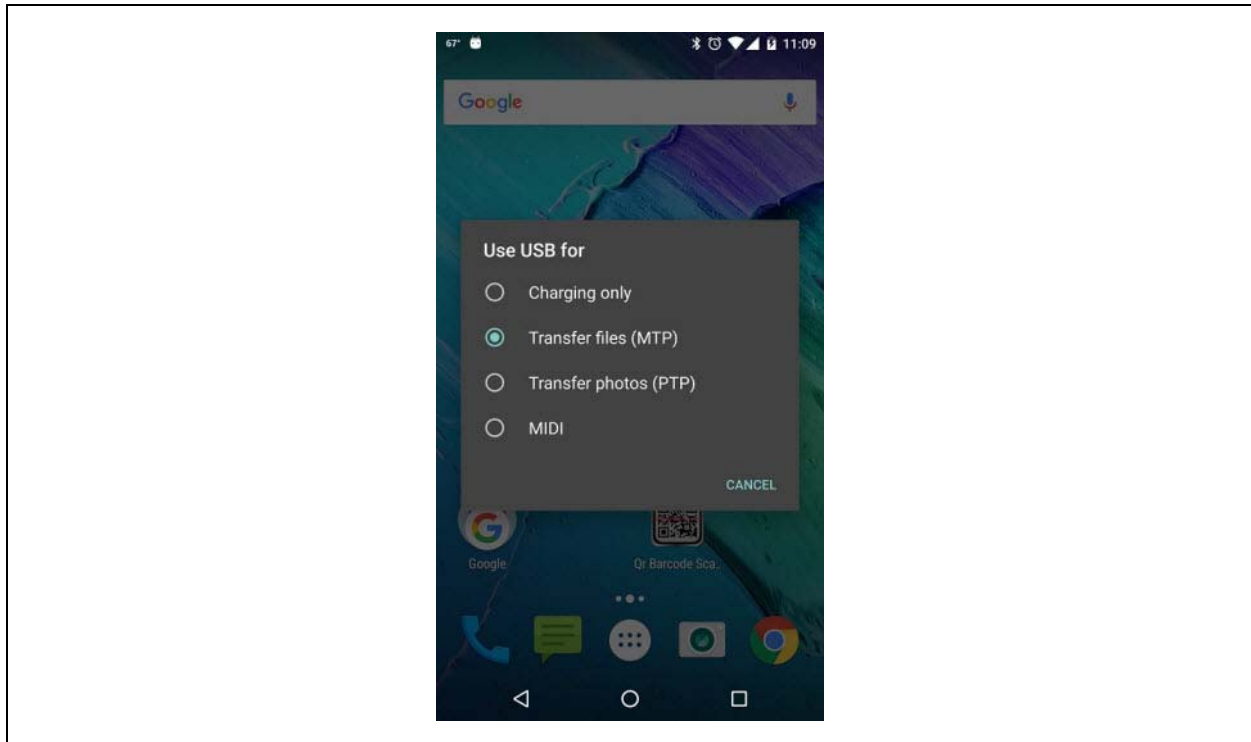

2. It is recommended to copy the Microchip Bluetooth Audio Android App to the

Download folder of the Android mobile device, see [Figure 27](#).

FIGURE 27: DOWNLOAD FOLDER OF THE ANDROID DEVICE

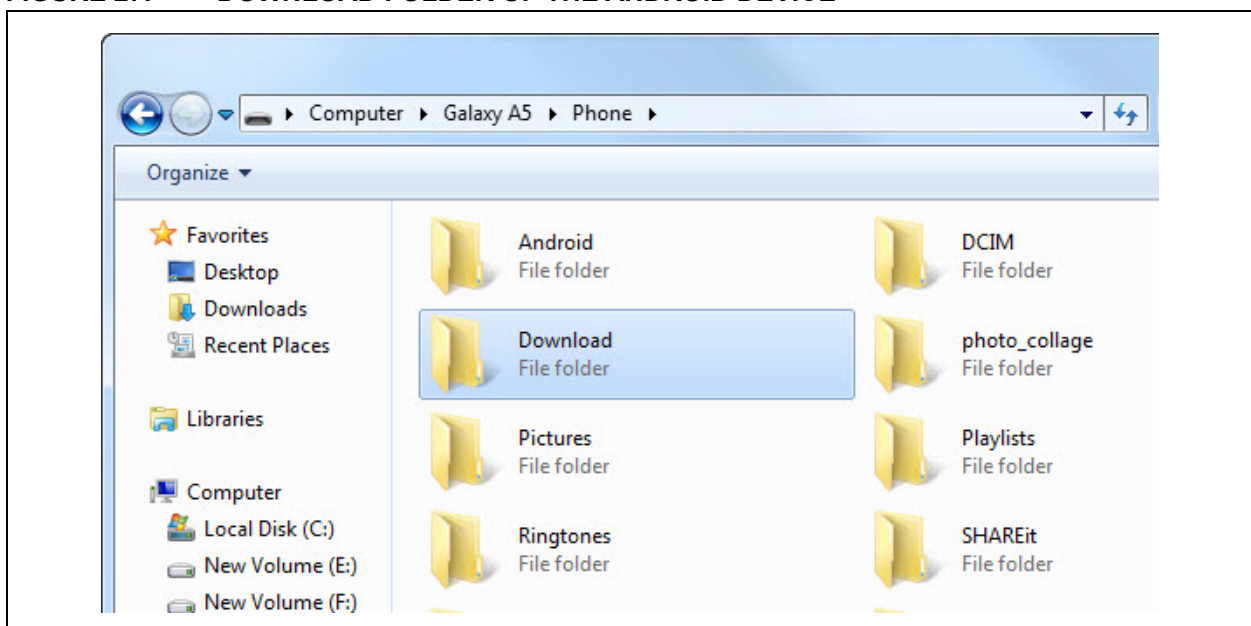

- From the **File Manager** of the mobile device, select *My Files > All Files > Download > MBA1_x_Android.apk*.

After selecting the file, a warning message indicating the installation is blocked is displayed, see [Figure 28](#).

FIGURE 28: WARNING MESSAGE: INSTALL BLOCKED

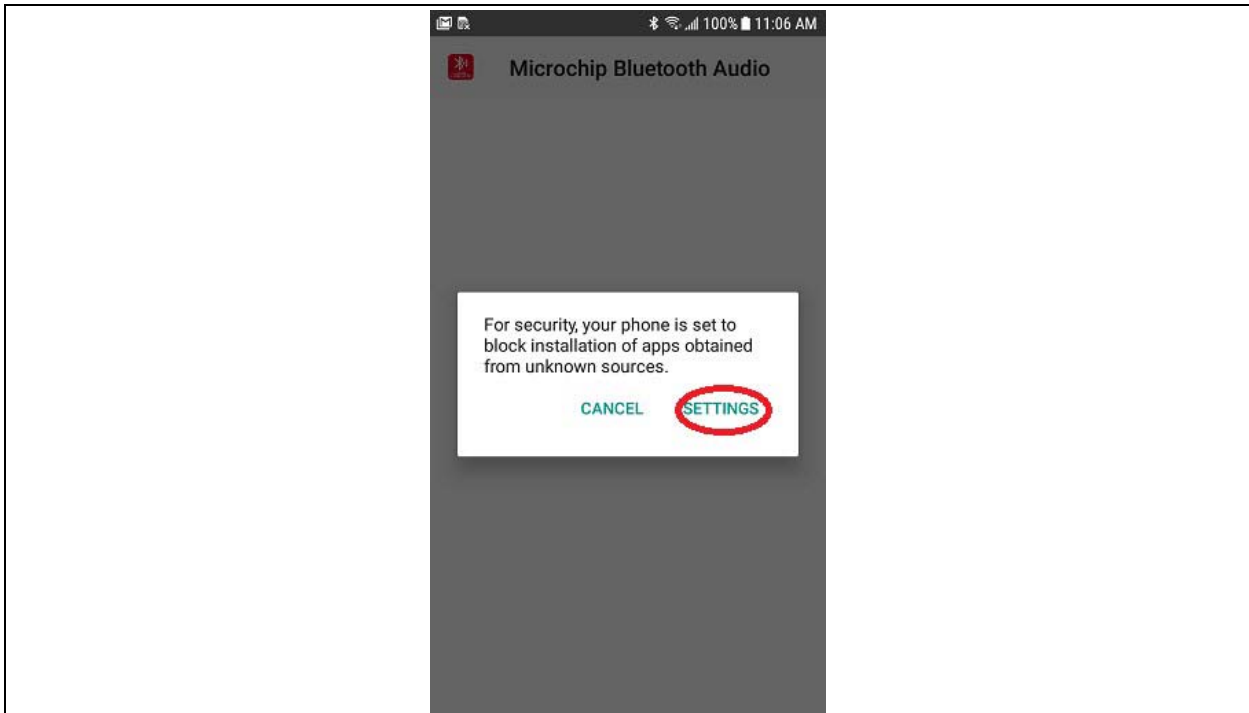

- Go to **Settings** to open the **Security** screen and enable installations from **Unknown sources**,

and then click **OK** to confirm the change, see [Figure 29](#).

FIGURE 29: ENABLE INSTALLATION FROM UNKNOWN SOURCES

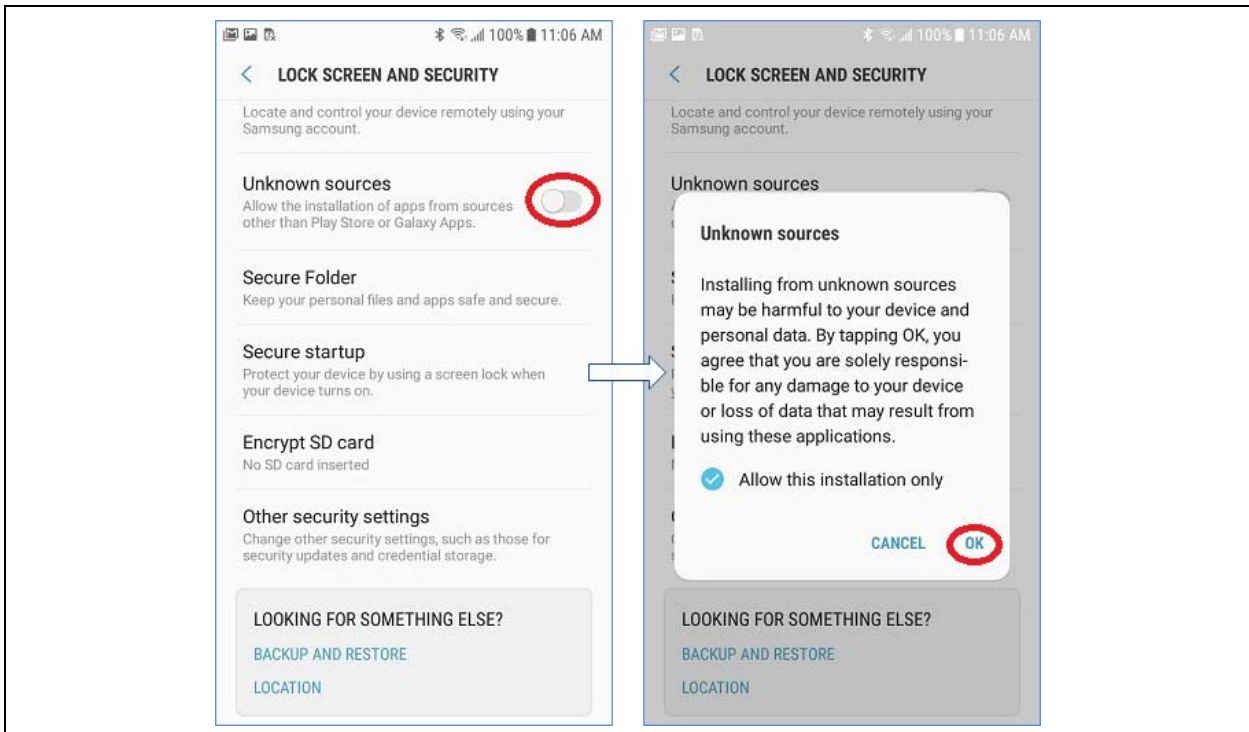

5. A message is displayed requesting whether to install an update to the existing application. Click **Install**. A confirmation screen displays when the

application is installed, and then click **Open** to run the application, see [Figure 30](#).

FIGURE 30: UPDATE AND INSTALL THE APP

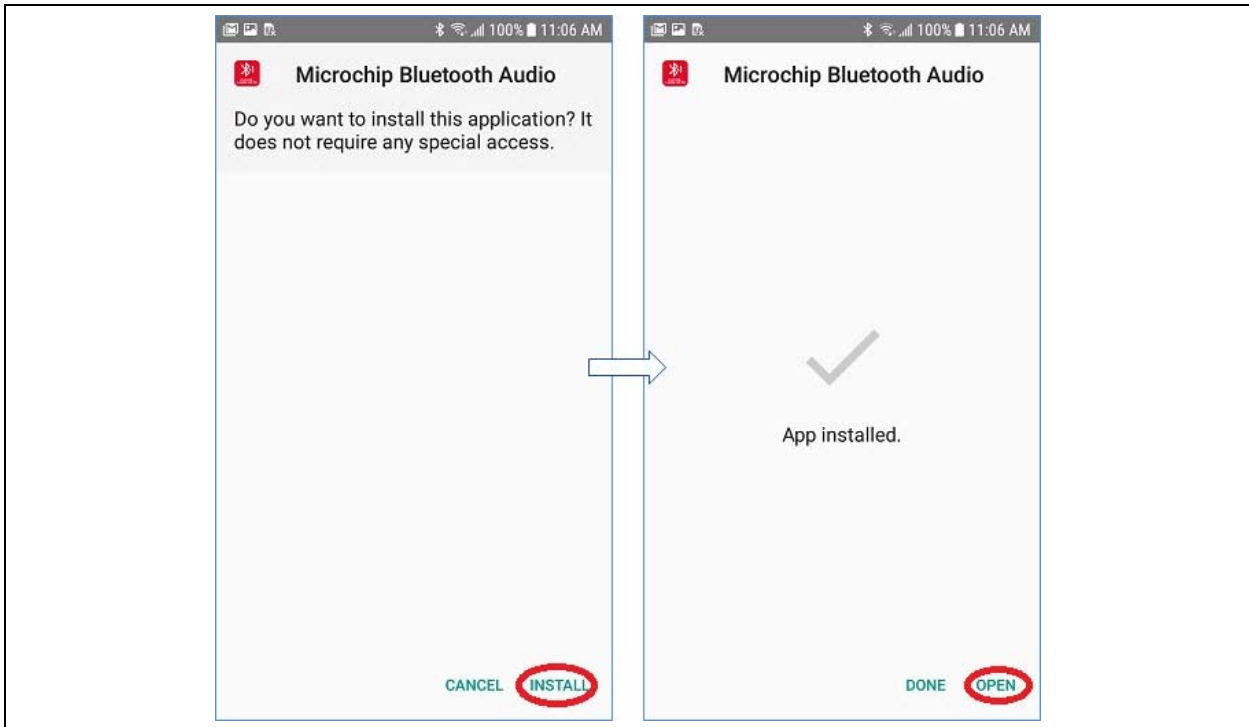

6. The app starts scanning and the timeout is for 30 seconds. A notification is displayed as "This app

needs location access", click **OK** and then select **Allow**, as illustrated in [Figure 31](#).

FIGURE 31: LOCATION ACCESS

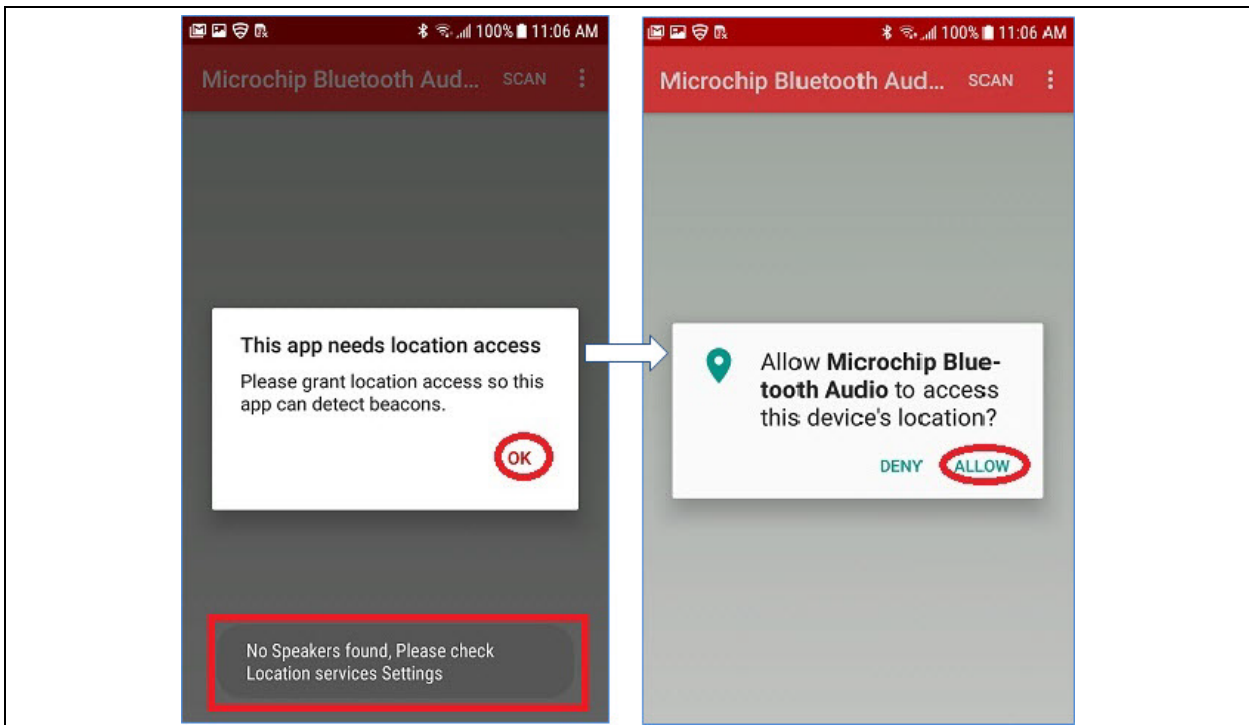

7. Click **SCAN** to see the list of discoverable devices nearby, as illustrated in [Figure 32](#).

FIGURE 32: UPDATE AND INSTALL THE

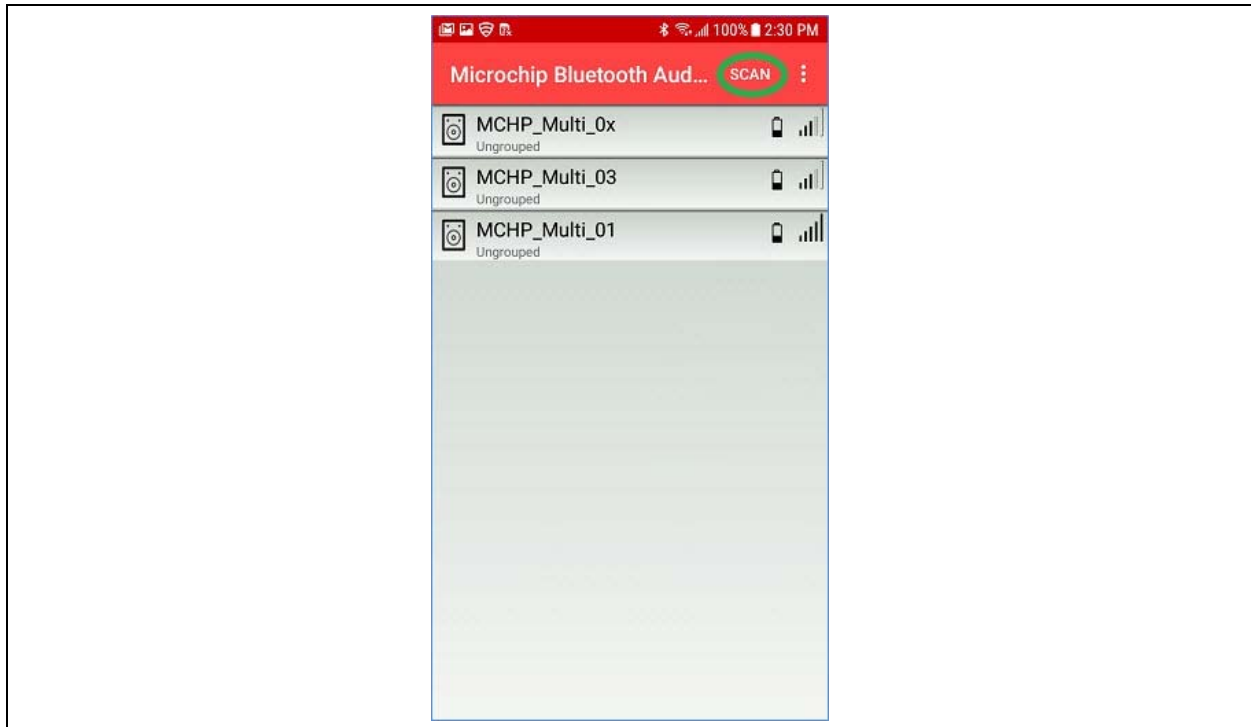

APPENDIX B: CUSTOMIZING UI AND DSP PARAMETERS

1. Open the UI tool, `UITool_IS206xGM_002_nSPK_v1.x.x.exe` from `Tools\UI Tool`. Click **Load** to load `UITool_IS206XGM_002_BM64_EVB.txt` from the same folder path and then click **Open**, see [Figure 33](#).

B.1 Customizing UI Parameters

Perform the following steps to customize the UI parameters:

FIGURE 33: LOADING UI FILE

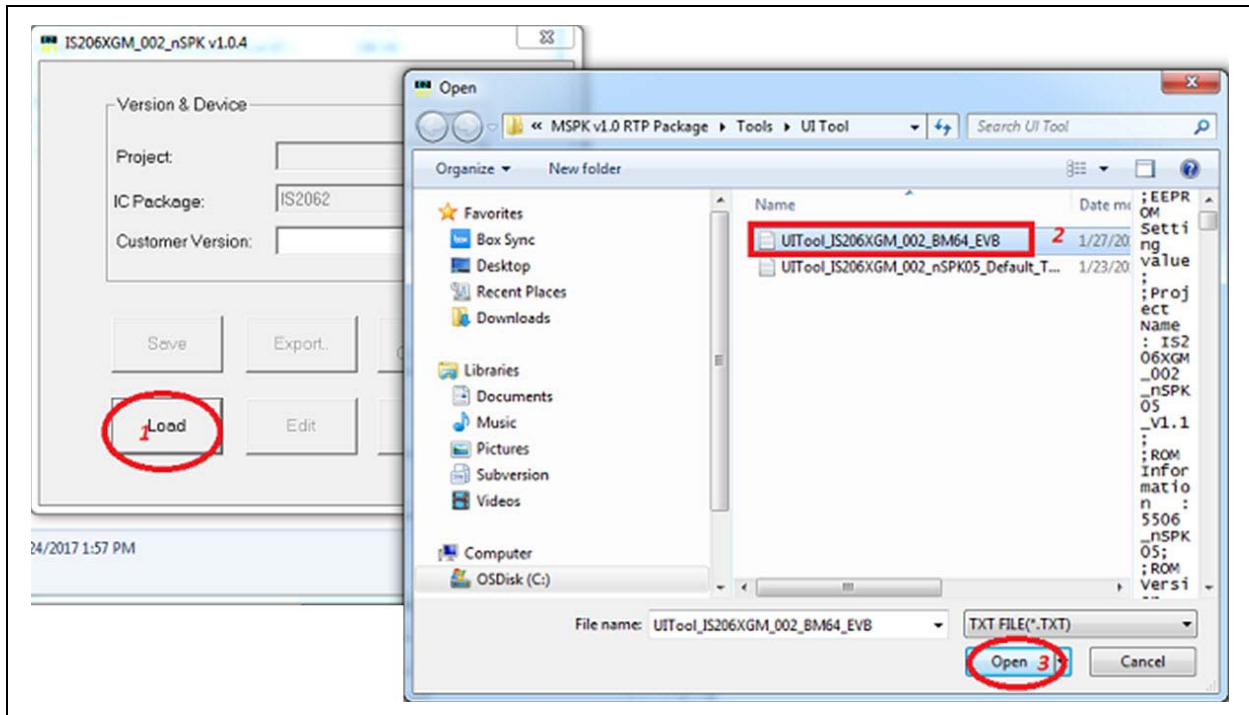

2. From the UI tool, click **Edit**, see [Figure 34](#).

FIGURE 34: EDIT UI PARAMETERS

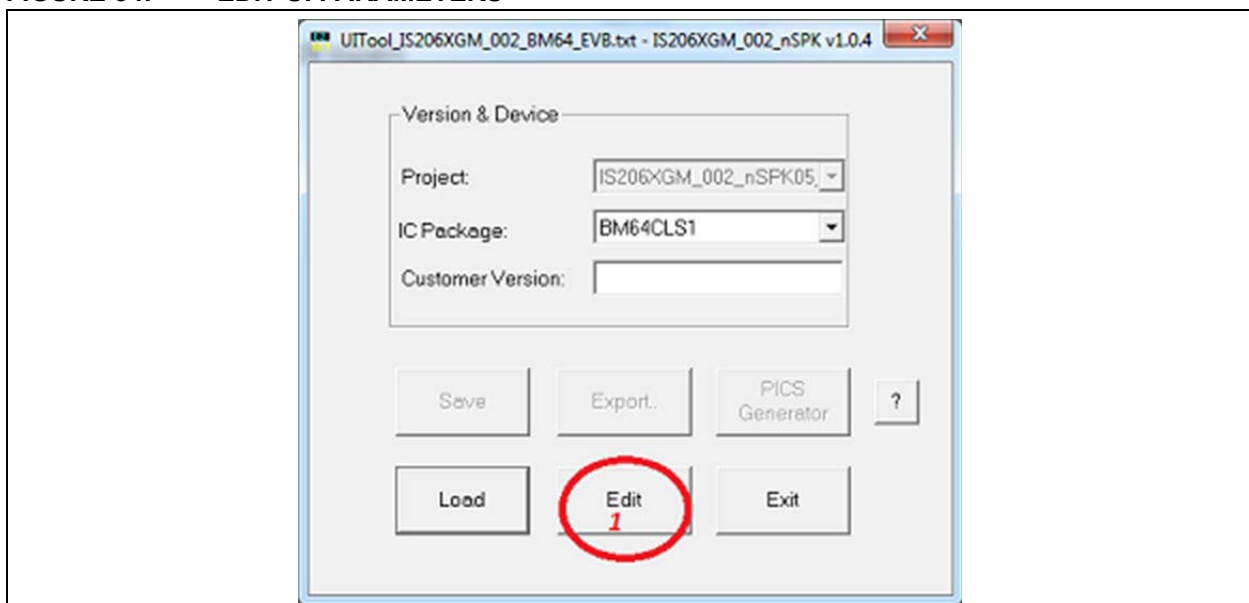

3. A window is displayed, click **Next**, see [Figure 35](#).

FIGURE 35: MAIN FEATURE SETTINGS

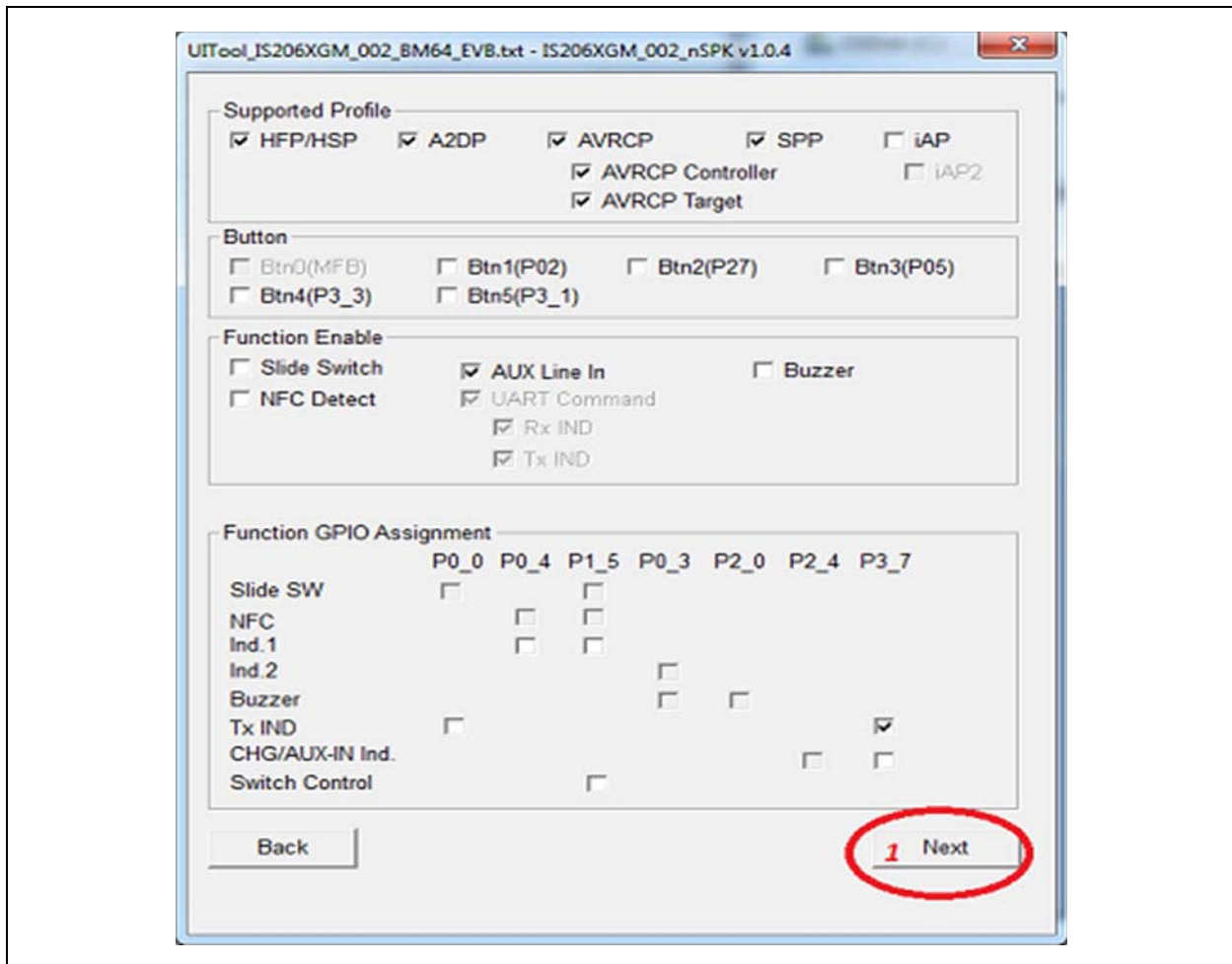

4. Click the **Sys. Setup2** tab to change the speaker name, as illustrated in [Figure 36](#) and then click **Finish**.

FIGURE 36: CHANGING SPEAKER NAME

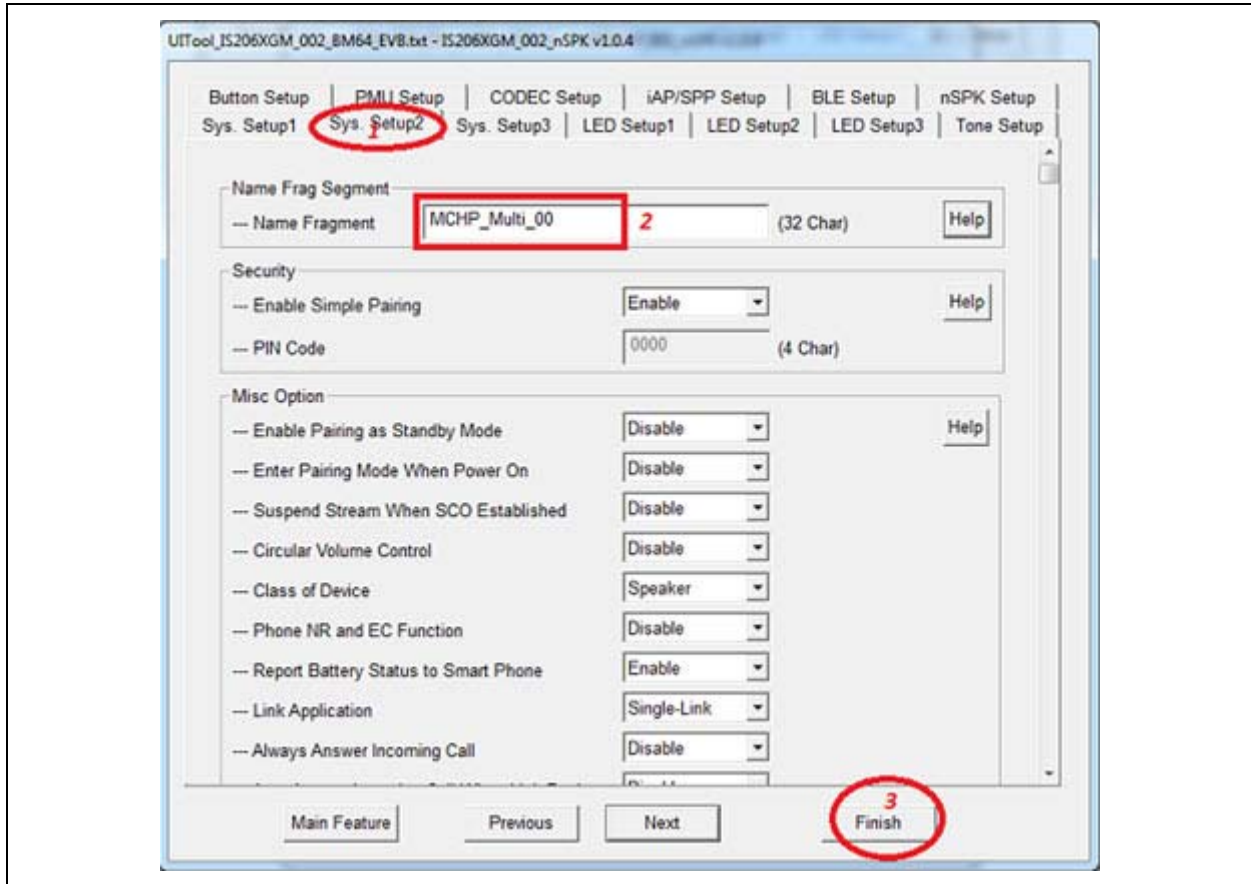

5. Click **Exit**, a window is displayed. From the Save As window, select the file location, and then click **Save**, see [Figure 37](#).

FIGURE 37: SAVING UI PARAMETERS

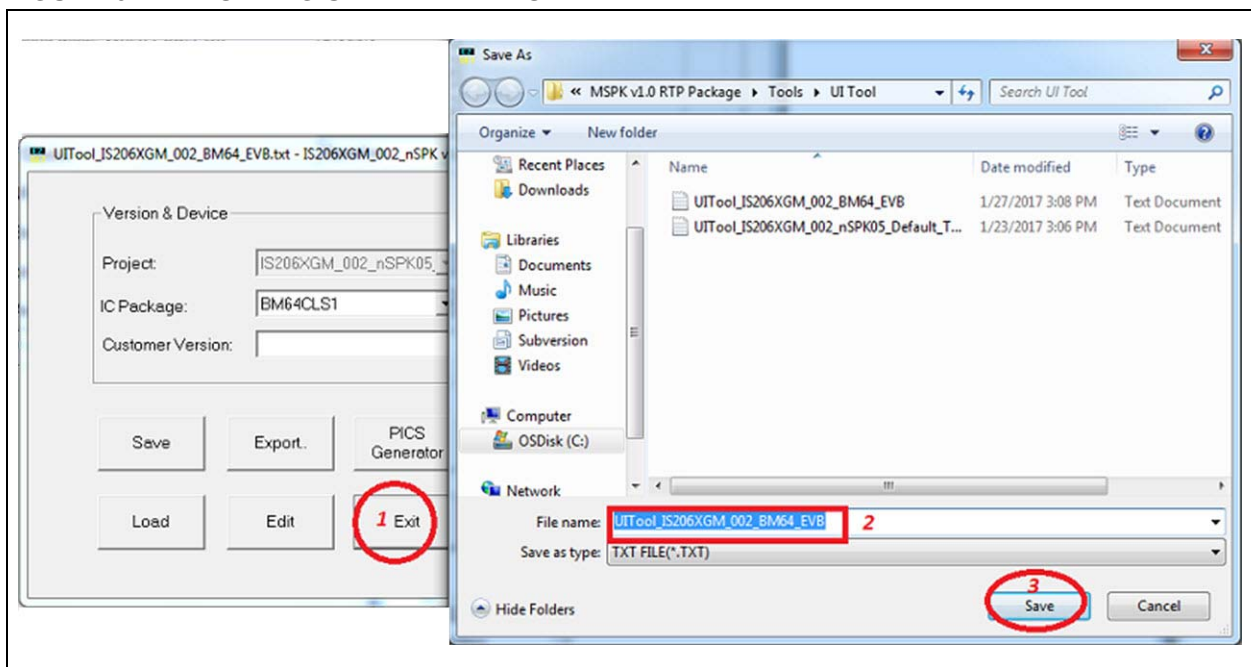

B.2 Customizing DSP Parameters

Perform the following steps to customize the DSP parameters:

1. Open the DSP Tool, DSPTool_IS206XGM_002

_nSPK05_V1.1_DSP_V1.xx.exe from tools\DSP Tool. Click **Load** to load MSPK_BM64_I2S_Master.txt from the same folder path, as illustrated in Figure 38.

FIGURE 38: LOADING DSP PARAMETERS

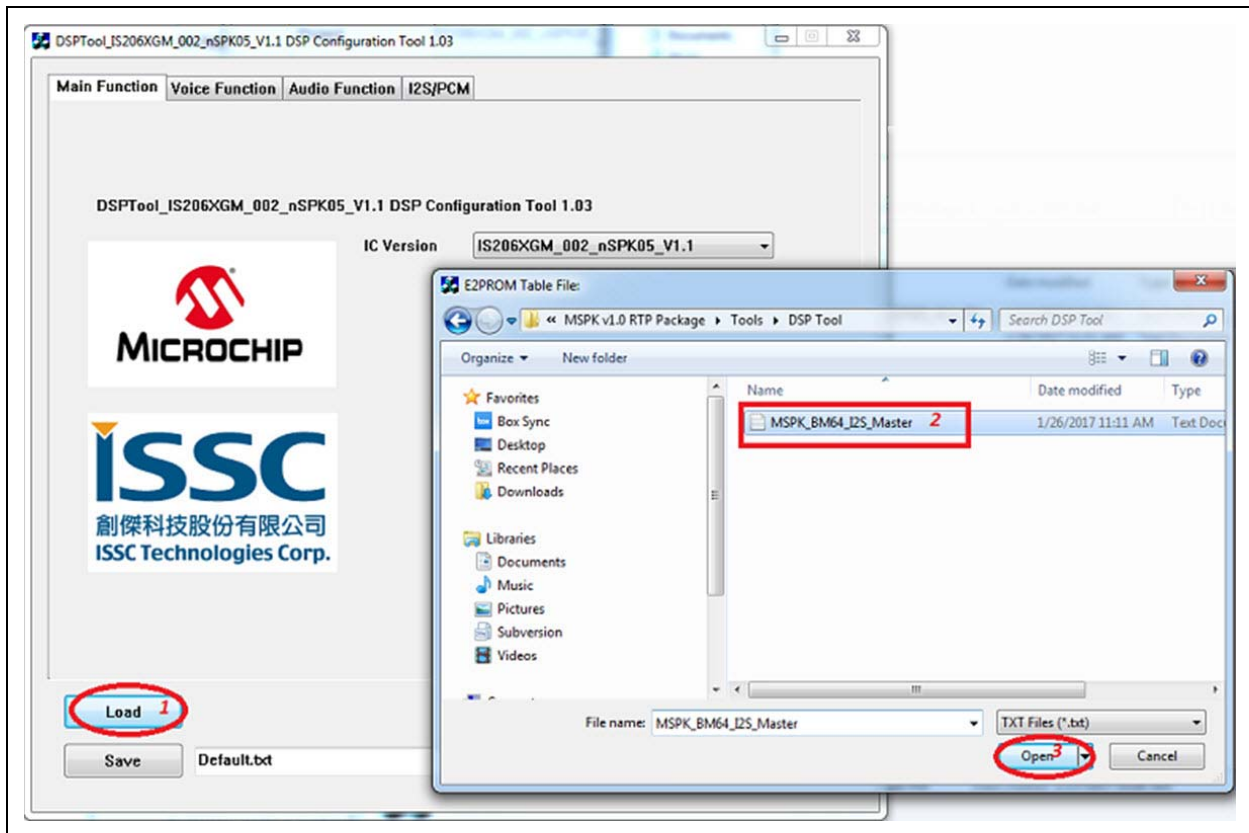

2. Click the **I2S/PCM** tab and perform the I²S related selection, as illustrated in Figure 39.

FIGURE 39: I2S/PCM SETTINGS

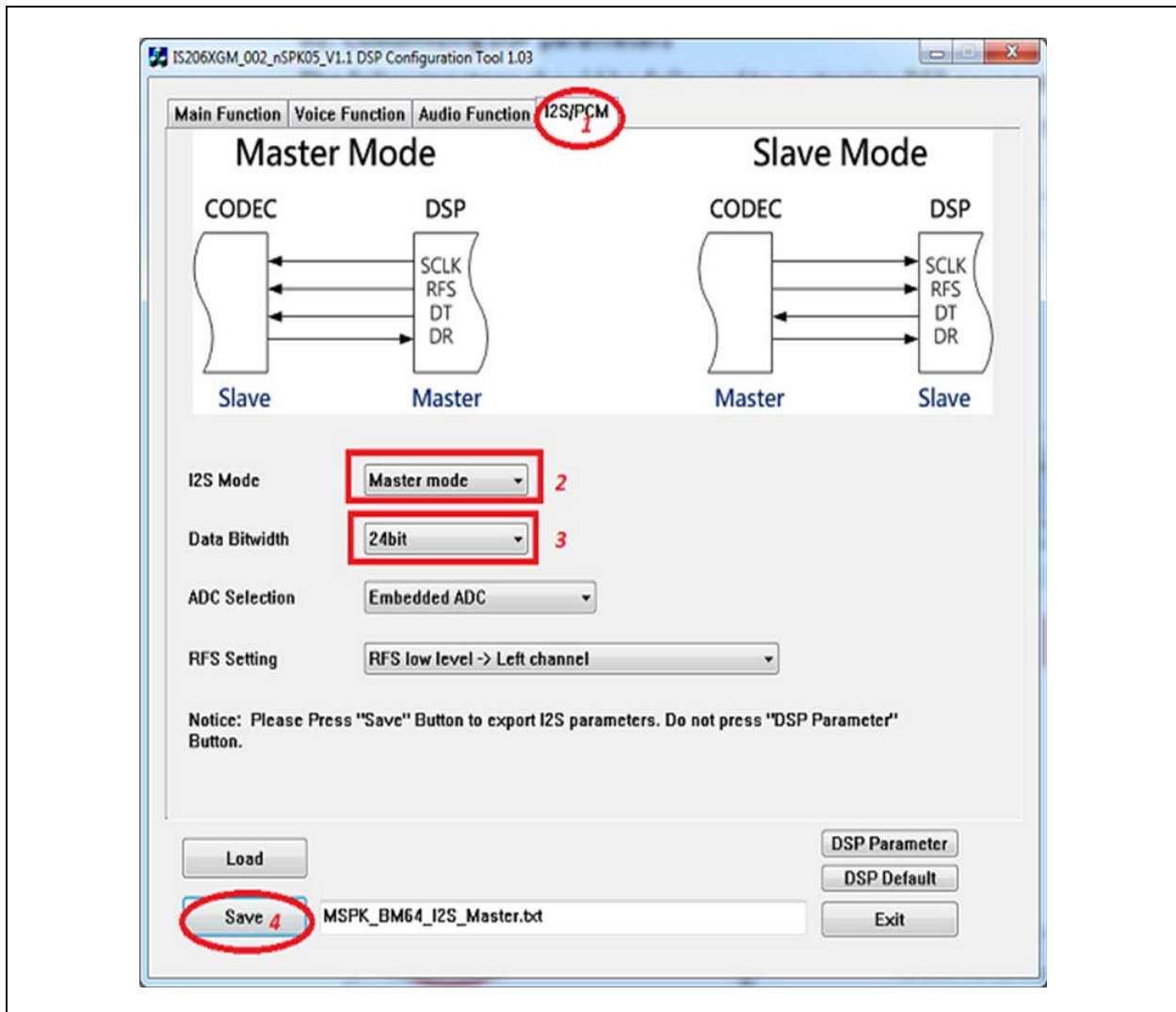

3. Click **Save** to save the settings as a .txt file, as illustrated in Figure 40.

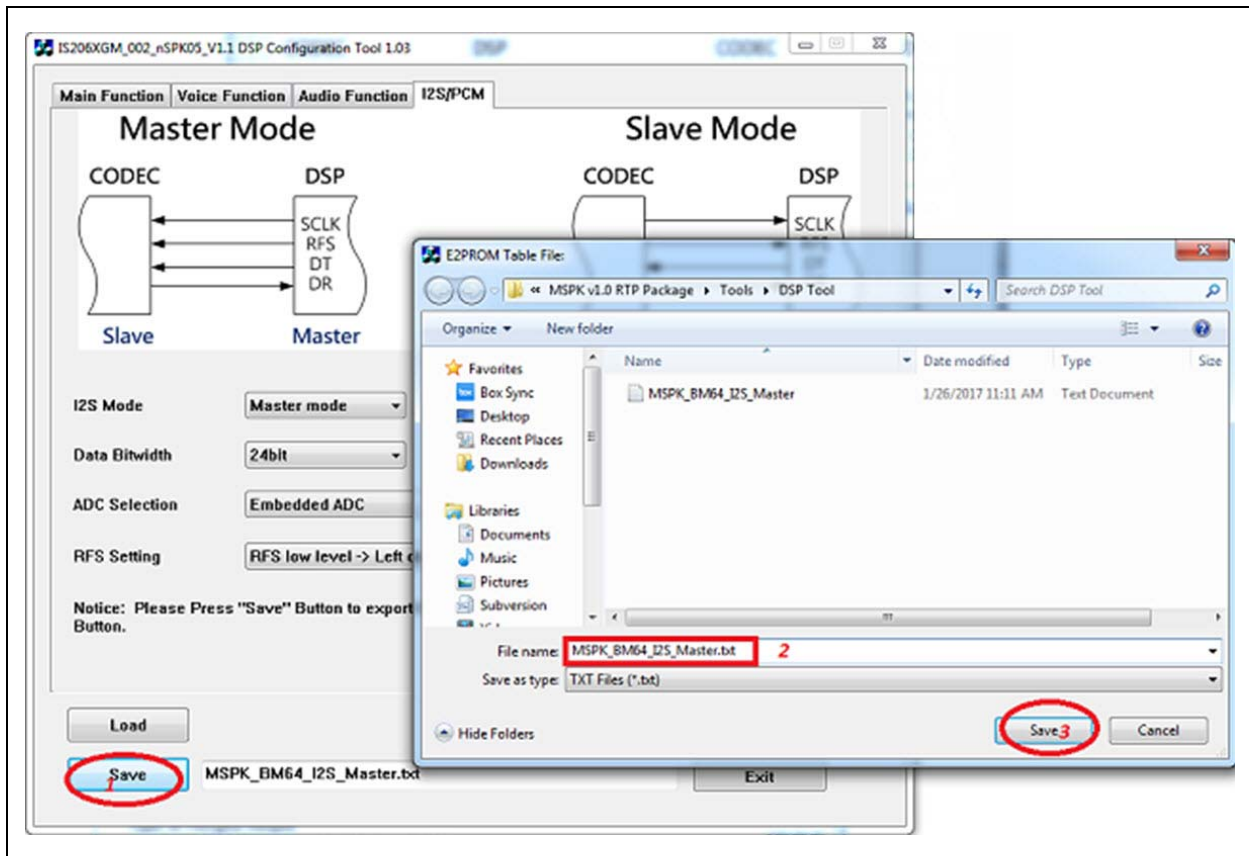
FIGURE 40: SAVING DSP PARAMETERS

B.3 Creating *.ipf file

select **UI Patch Only** and then click **Next**, as illustrated in Figure 41.

Perform the following steps to create *.ipf file:

1. Open MPET tool, MPET.exe from Tools\MP_Tools_V2.1.xx.xxxx folder,

FIGURE 41: SELECTING .ipf OUTPUT FORMAT

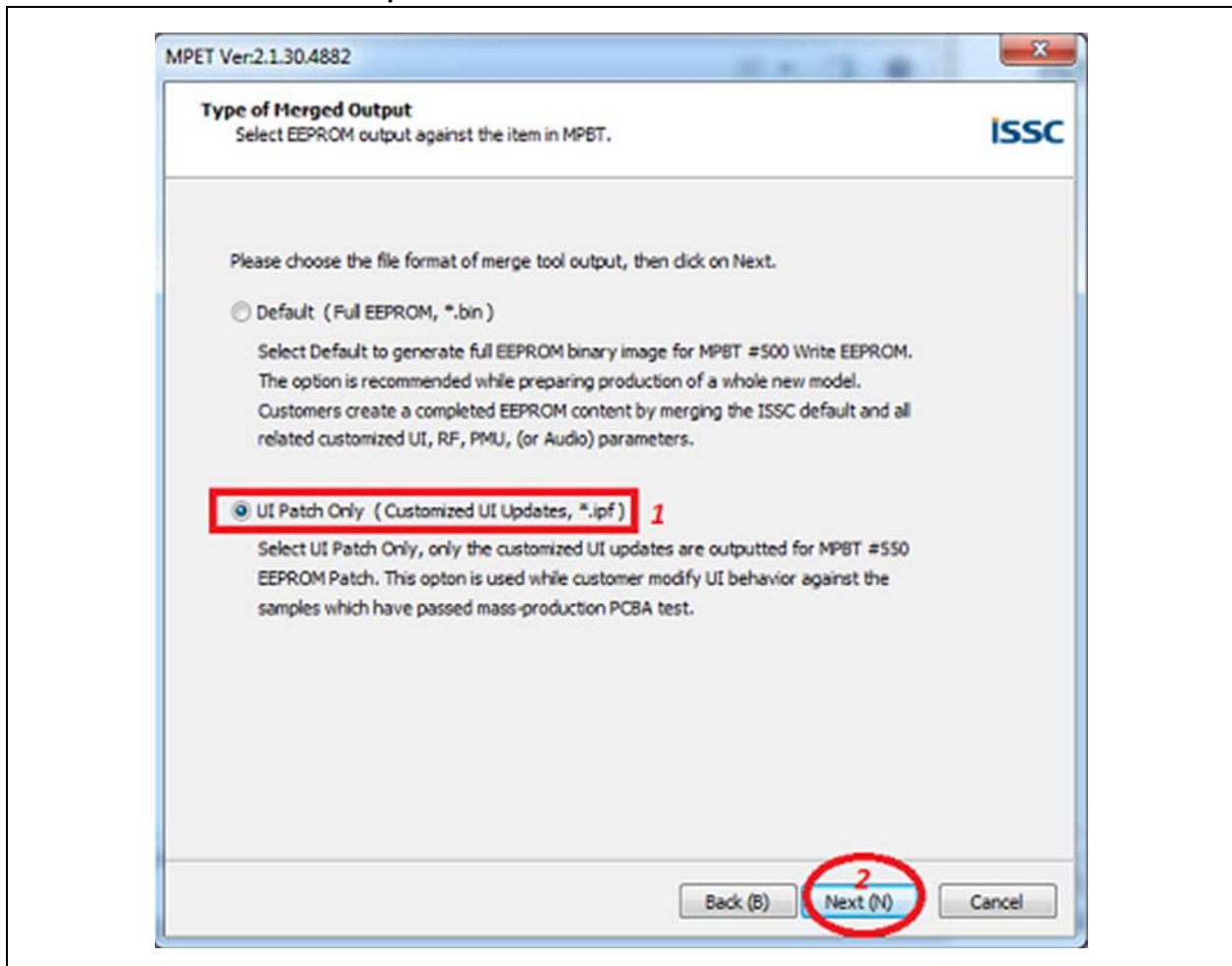

- Click **Browse** and select IS206XGM_002_nSPK05_V1.1_E1.x.x.x_xxxx.bin from Tools\MP_Tools_V2.1.xx.xxxx\issc_default_bin folder. Select the "Load default

bin into IPF" check box and then click **Next**, as illustrated in [Figure 42](#).

FIGURE 42: LOADING DEFAULT BIN FILE

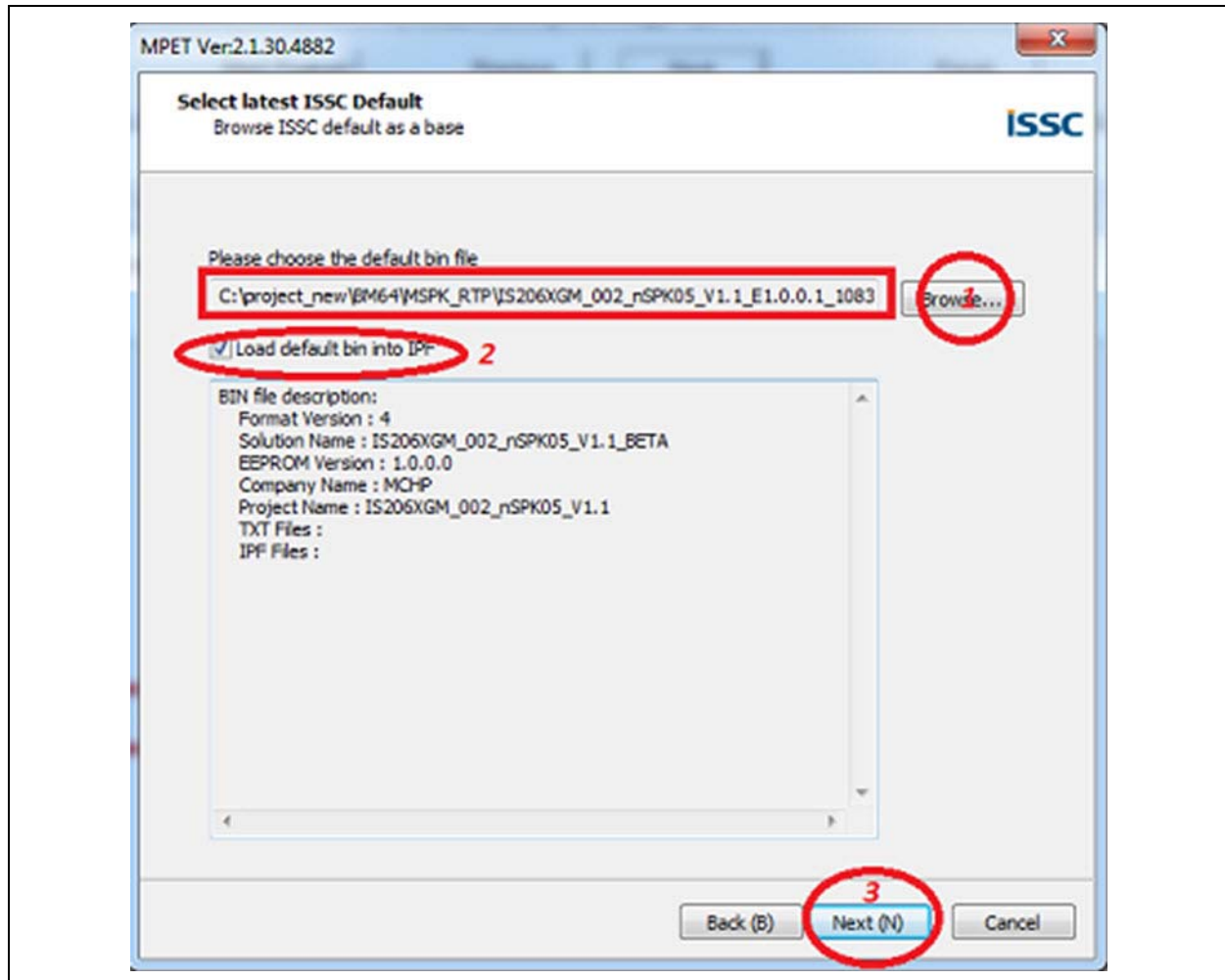

- Click "+" and select MSPK_BM64_I2S_Master.txt and UITool_IS206XGM_002_BM64_EVB.txt, as illustrated in Figure 43 and then click Next.

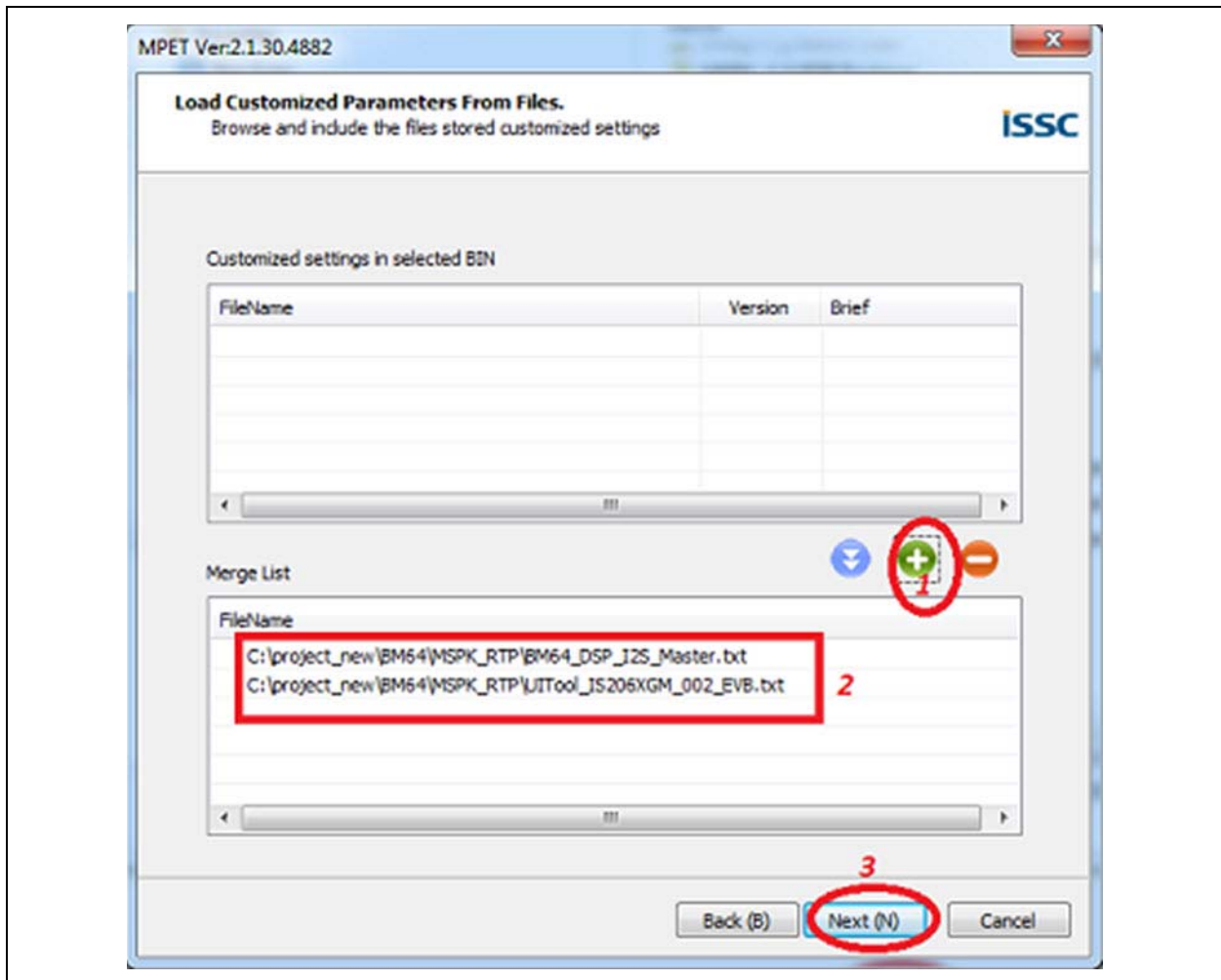
FIGURE 43: LOADING CUSTOMIZED UI AND DSP PARAMETERS

4. Select the output file name and path to create the *.ipf file as illustrated in [Figure 44](#), and then click **Next**.

FIGURE 44: SELECTING OUTPUT FILE NAME AND PATH

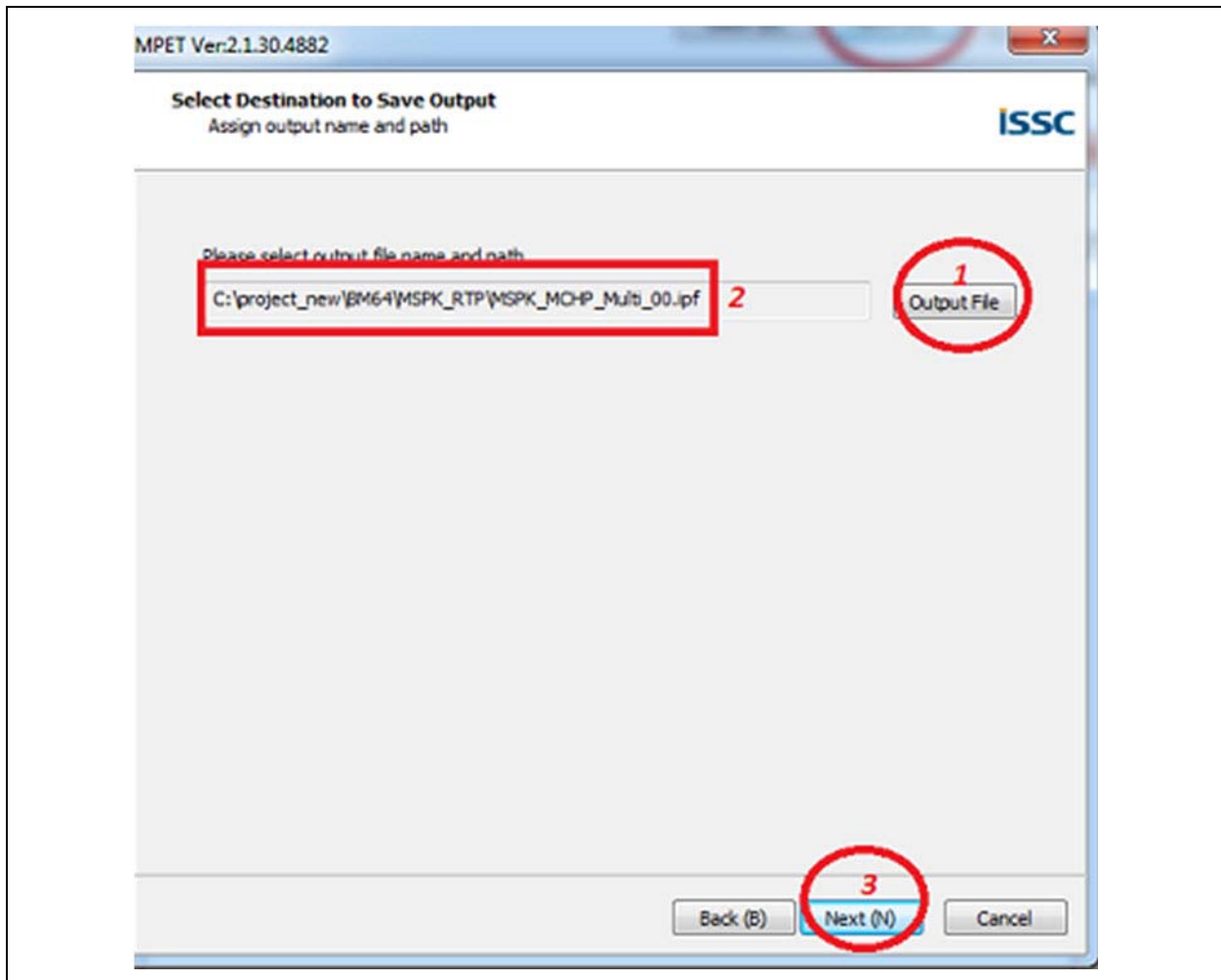

5. Click **Generate** to generate the *.ipf file, as illustrated in Figure 45.

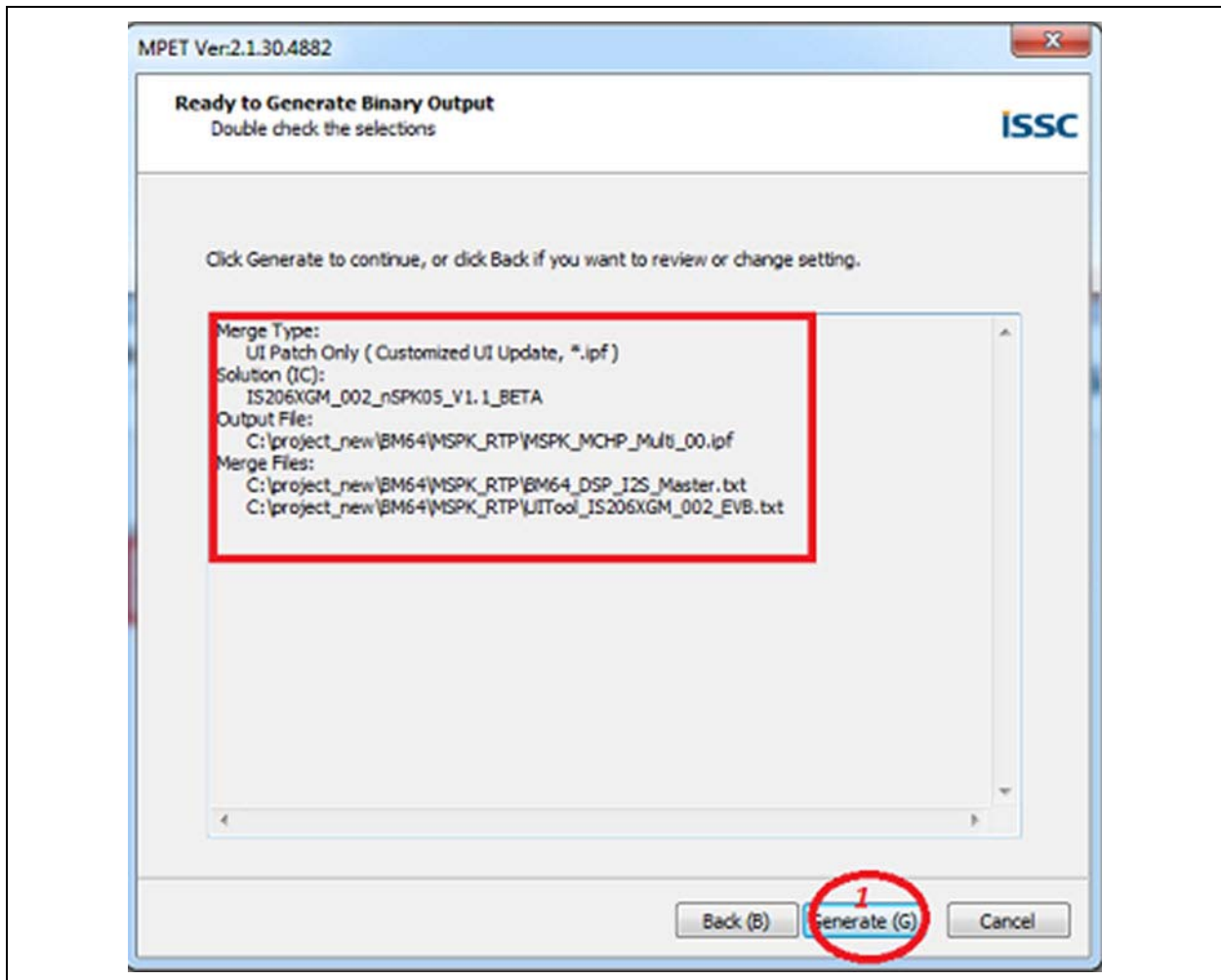
FIGURE 45: GENERATE IPF FILE

6. After generating the *.ipf file, click **Finish**, see [Figure 46](#). The generated *.ipf can be directly programmed into BM64 modules.

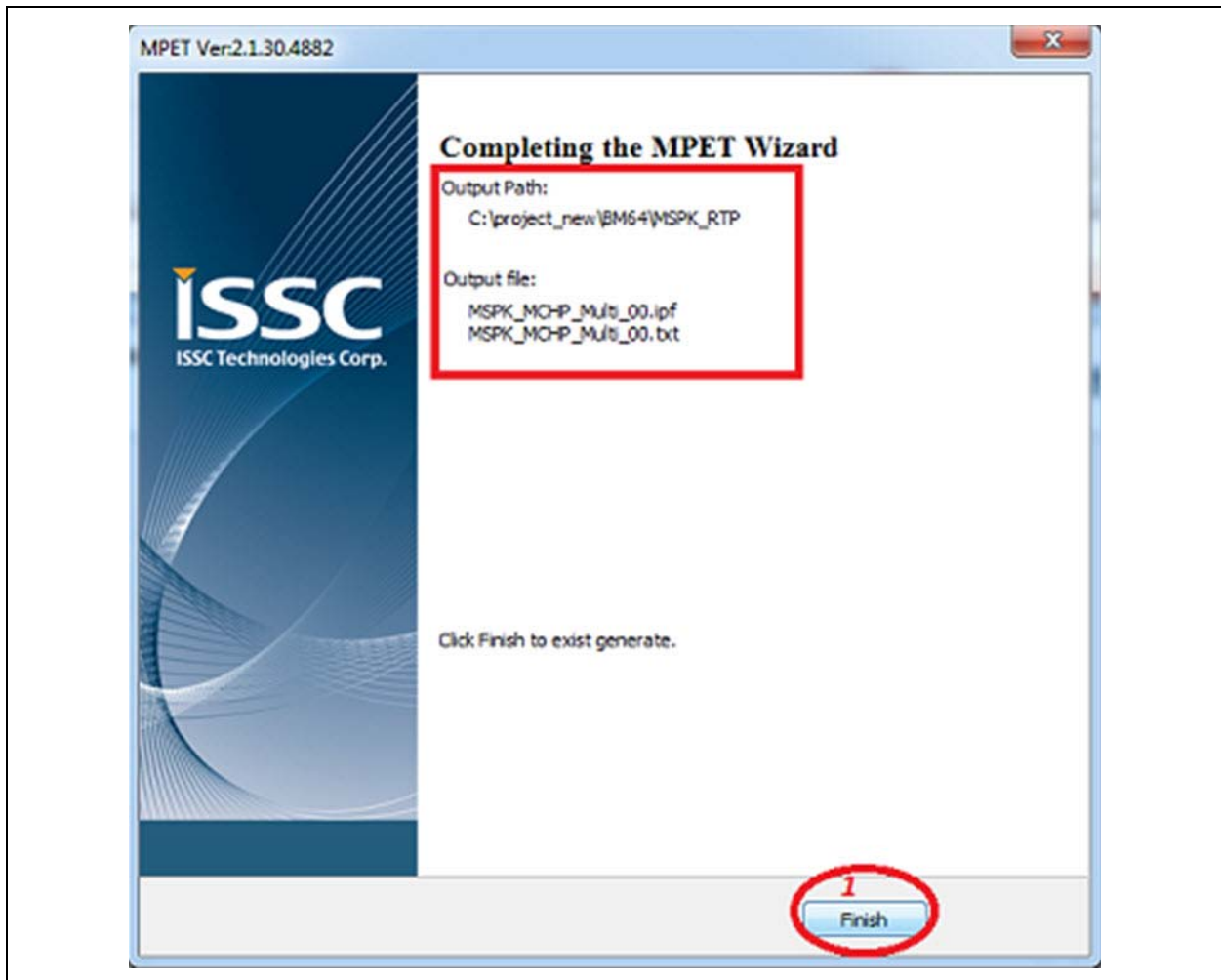
FIGURE 46: IPF FILE GENERATED

APPENDIX C: CONFIGURING BM64 I²S MASTER/SLAVE MODE AT 48 KHZ

BM64 I²S can be configured into I²S Master and I²S Slave modes. [Appendix B: “Customizing UI and DSP Parameters”](#) describes BM64 configured into I²S Master mode. This section describes BM64 configured into I²S Slave mode.

C.1 Selecting UI Parameters

Perform all the steps from [B.1 “Customizing UI Parameters”](#). The only difference is enabling Audio SRC and Voice SRC, as illustrated in [Figure 47](#). Click the **CODEC Setup** tab, enable **Audio SRC**, **Voice SRC** and then select “External CODEC” as **External codec**.

Voice Prompt and HFP can be enabled in Stereo mode. Enable **Tone Stereo** and **Voice Stereo**, as illustrated in [Figure 47](#).

FIGURE 47: CODEC SETUP

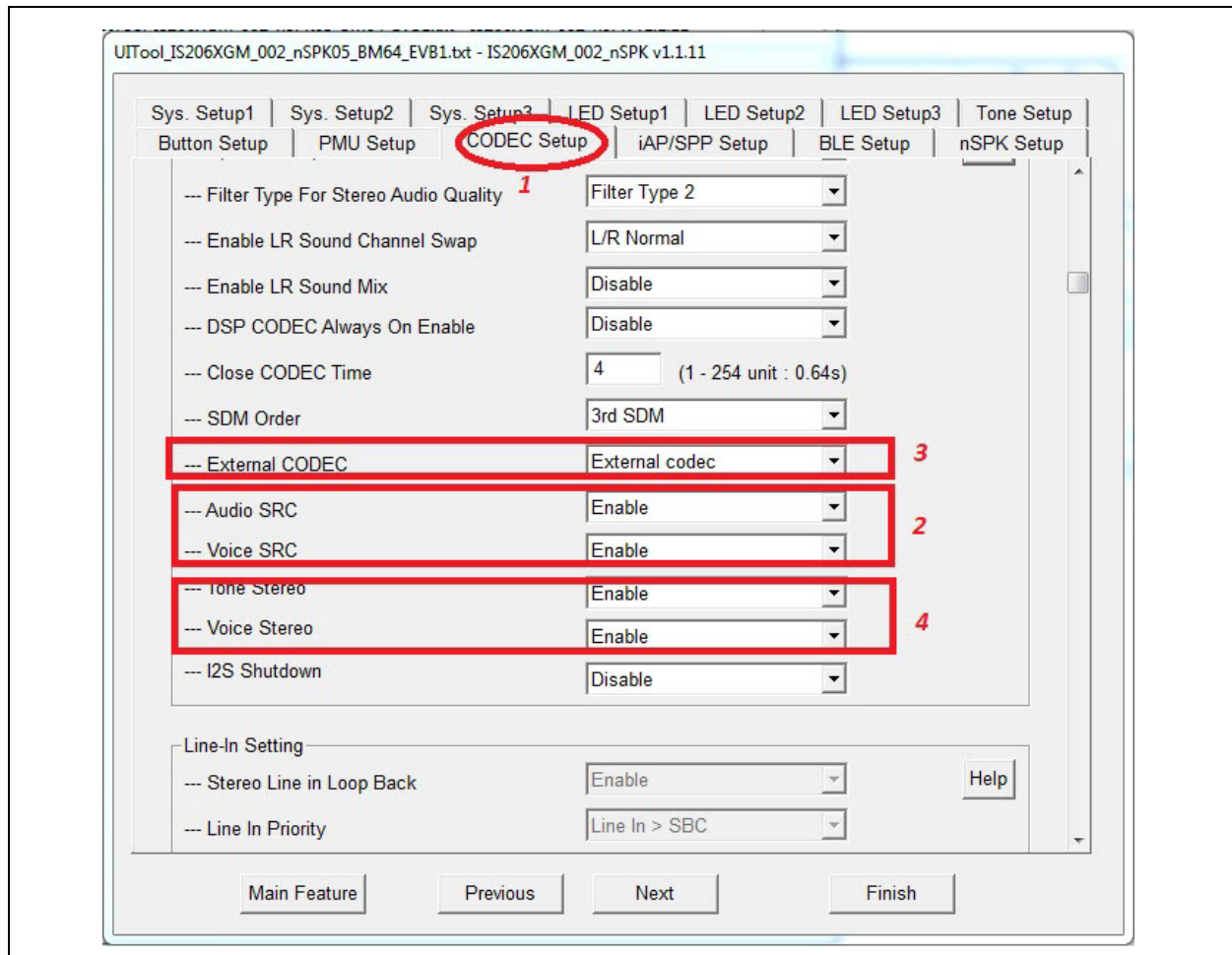

Note 1: If “External CODEC” is selected as internal codec then audio will be routed to analog speaker out.

2: For BM64 I²S Master mode at 48 kHz, refer to [C.1 “Selecting UI Parameters”](#), [B.2 “Customizing DSP Parameters”](#) and [B.3 “Creating *.ipf file”](#).

C.2 Selecting DSP Parameters

Perform all the steps from [B.2 “Customizing DSP Parameters”](#). The only difference is select I²S mode as Slave mode, as illustrated in [Figure 48](#).

FIGURE 48: I²S IN SLAVE MODE

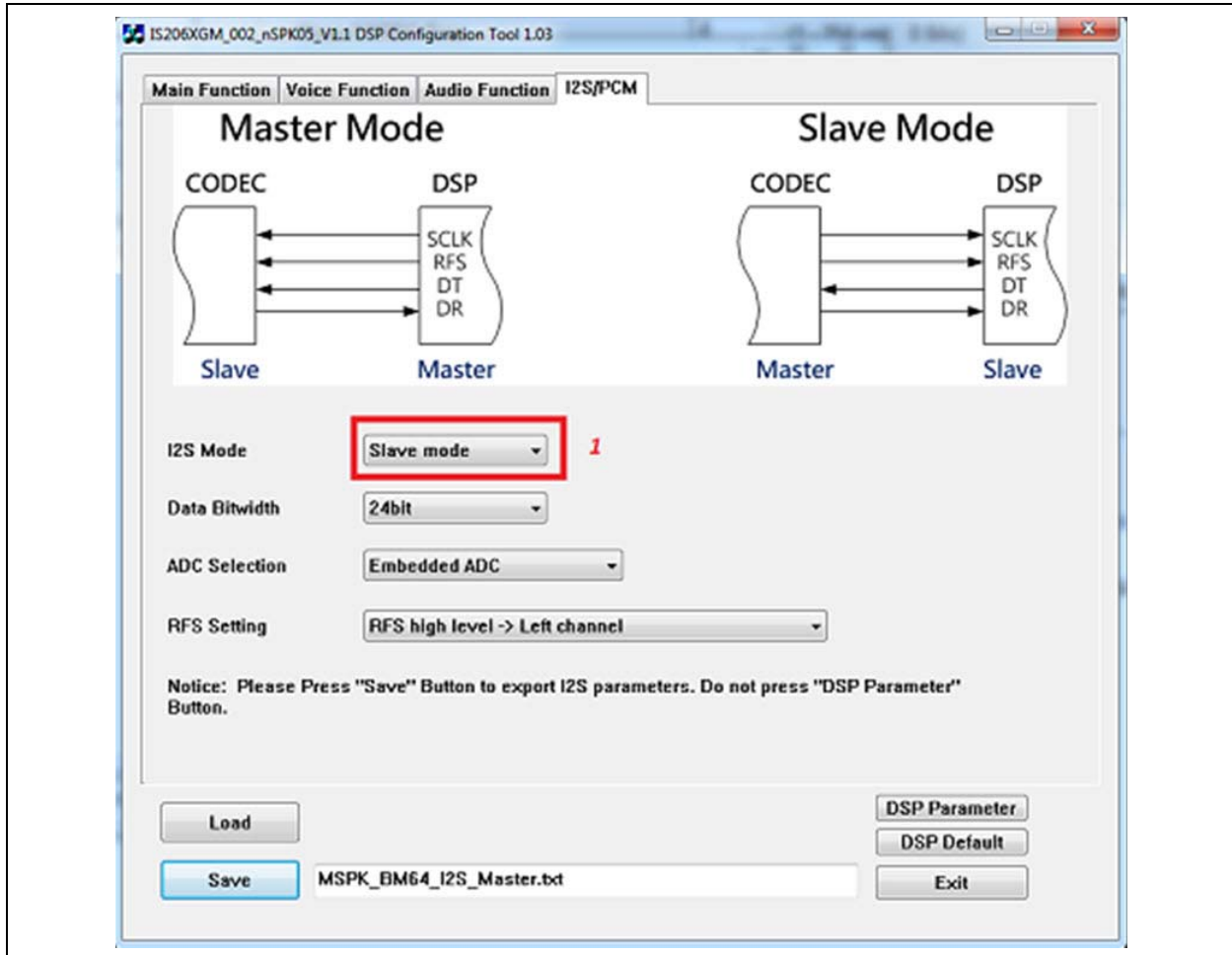

C.3 Creating *.ipf file

For the procedure to create the *.ipf file, refer to [B.3 “Creating *.ipf file”](#).

APPENDIX D: ANDROID APP POWER MODE

Microchip Bluetooth Audio App can also be used for power-on/off for an individual BM64 speaker. Touch **Power** to turn on/off the BM64 speaker, as illustrated in

Figure 49. If power is turned off on the master speaker then it will switch off master and all the connected slave speakers, similar to the short press of MFB on the master speaker.

FIGURE 49: POWER MODE ON/OFF

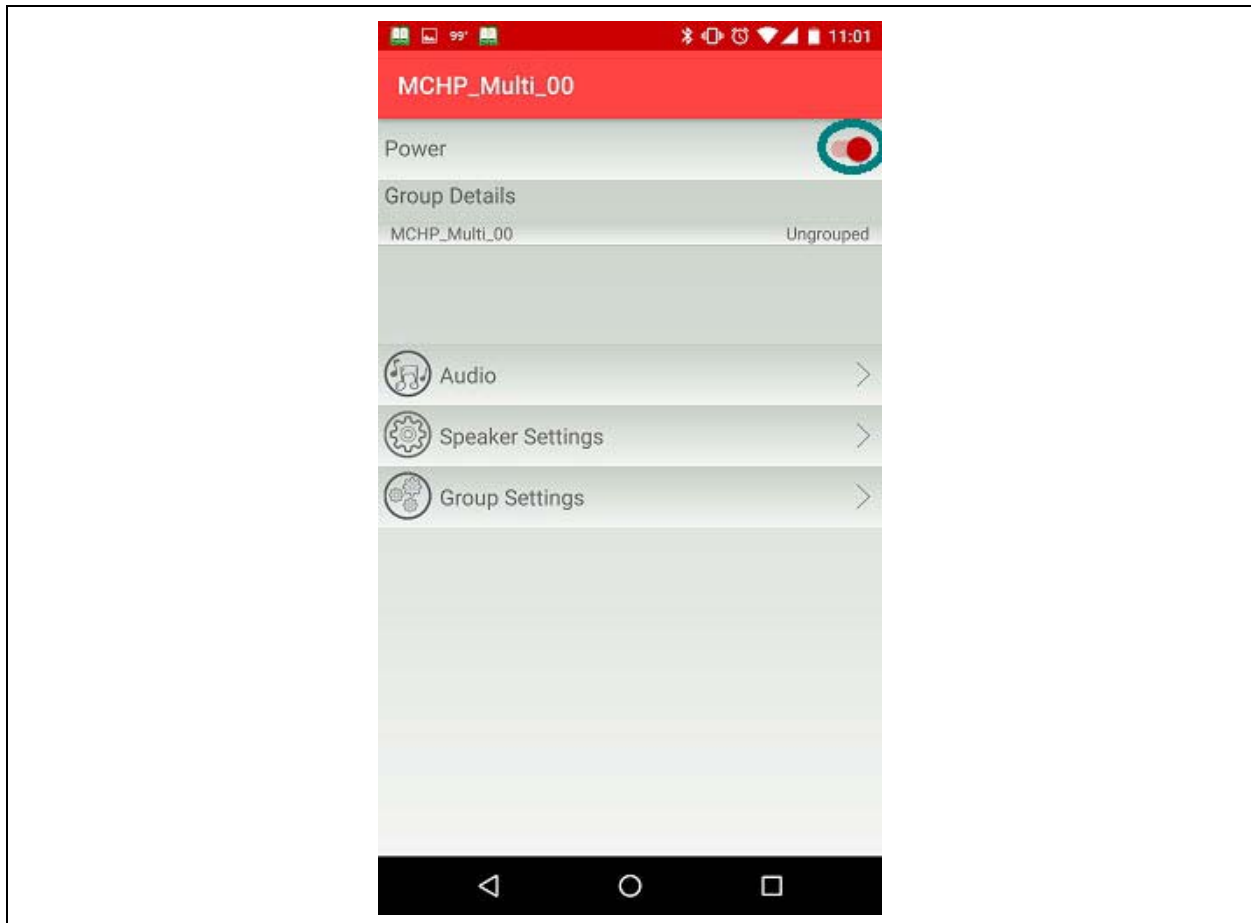

APPENDIX E: AVRCP VERSION

The AVRCP version 1.6/1.3 can be programmed, as illustrated in [Figure 50](#).

The volume control is performed on the source in AVRCP v1.3. The absolute volume is sent to sink in AVRCP v1.6.

FIGURE 50: SELECTING AVRCP VERSION

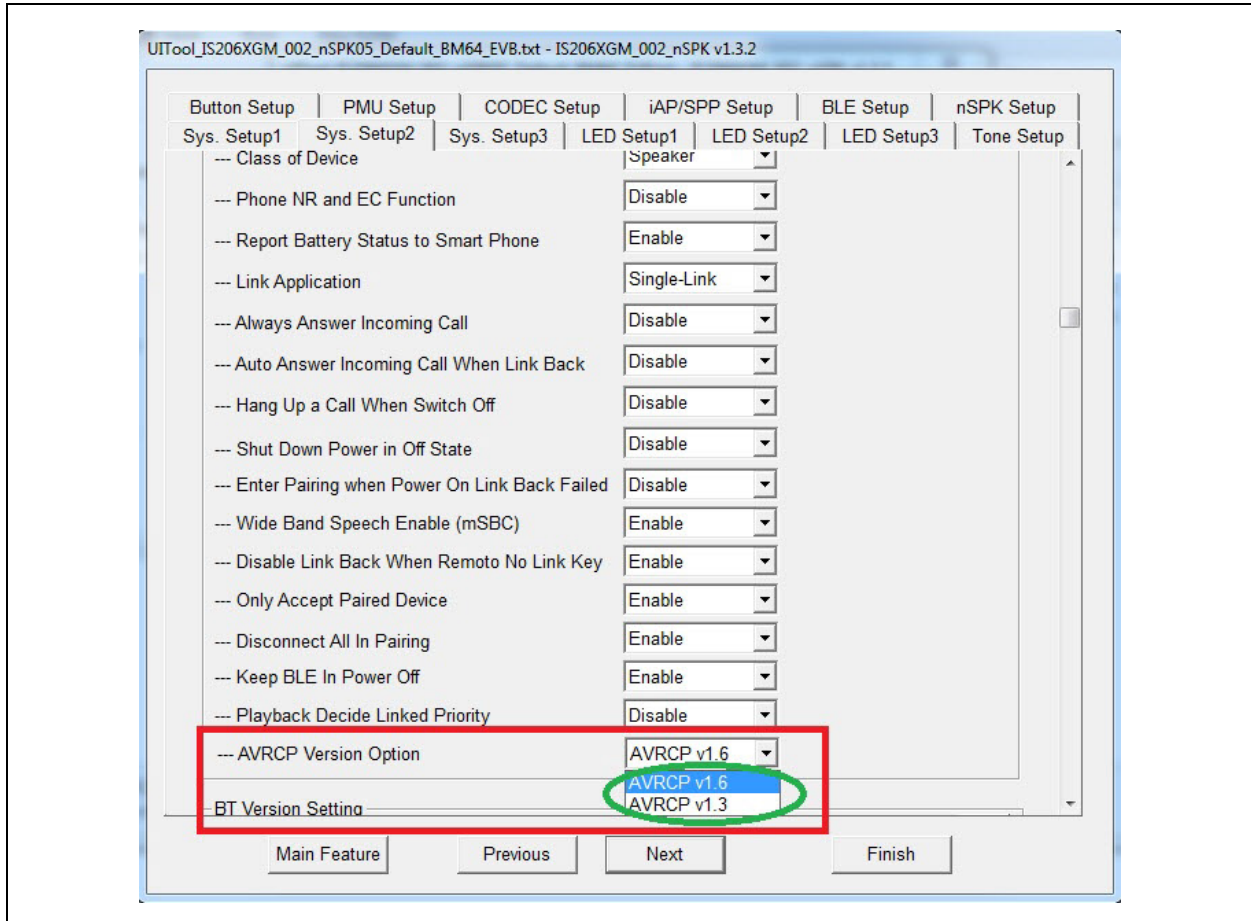

APPENDIX F: AAC CODEC

AAC codec can be enabled, as illustrated in [Figure 51](#).

FIGURE 51: ENABLE AAC CODEC

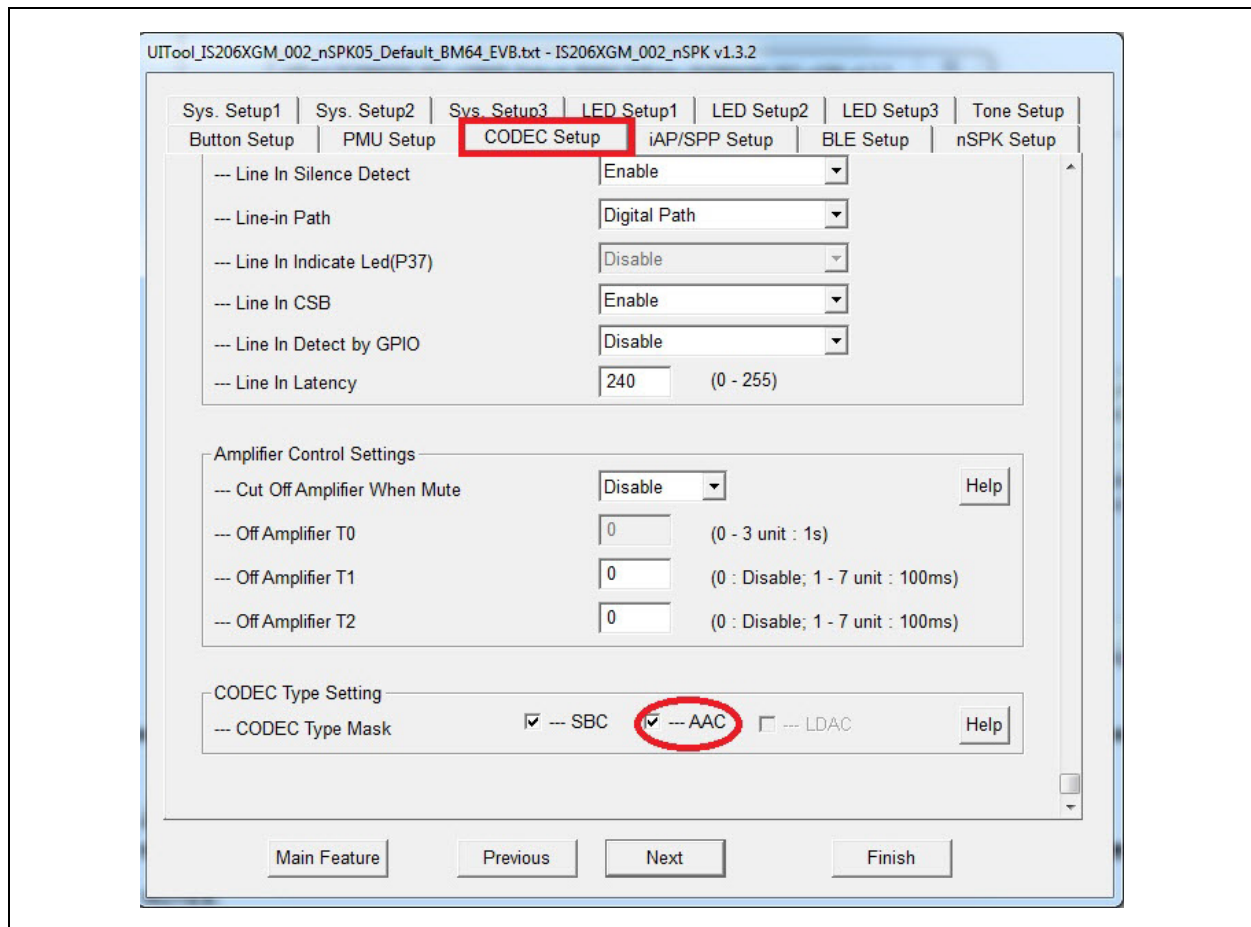

APPENDIX G: PROGRAMMING AUX-IN LATENCY

The value must be 3 times the intended latency value. i.e. for 20 ms delay, Line In Latency = $20 \times 3 = 60$.

The AUX-In latency can be programmed from 20 ms to 80 ms, as illustrated in [Figure 52](#).

FIGURE 52: AUX-IN LATENCY

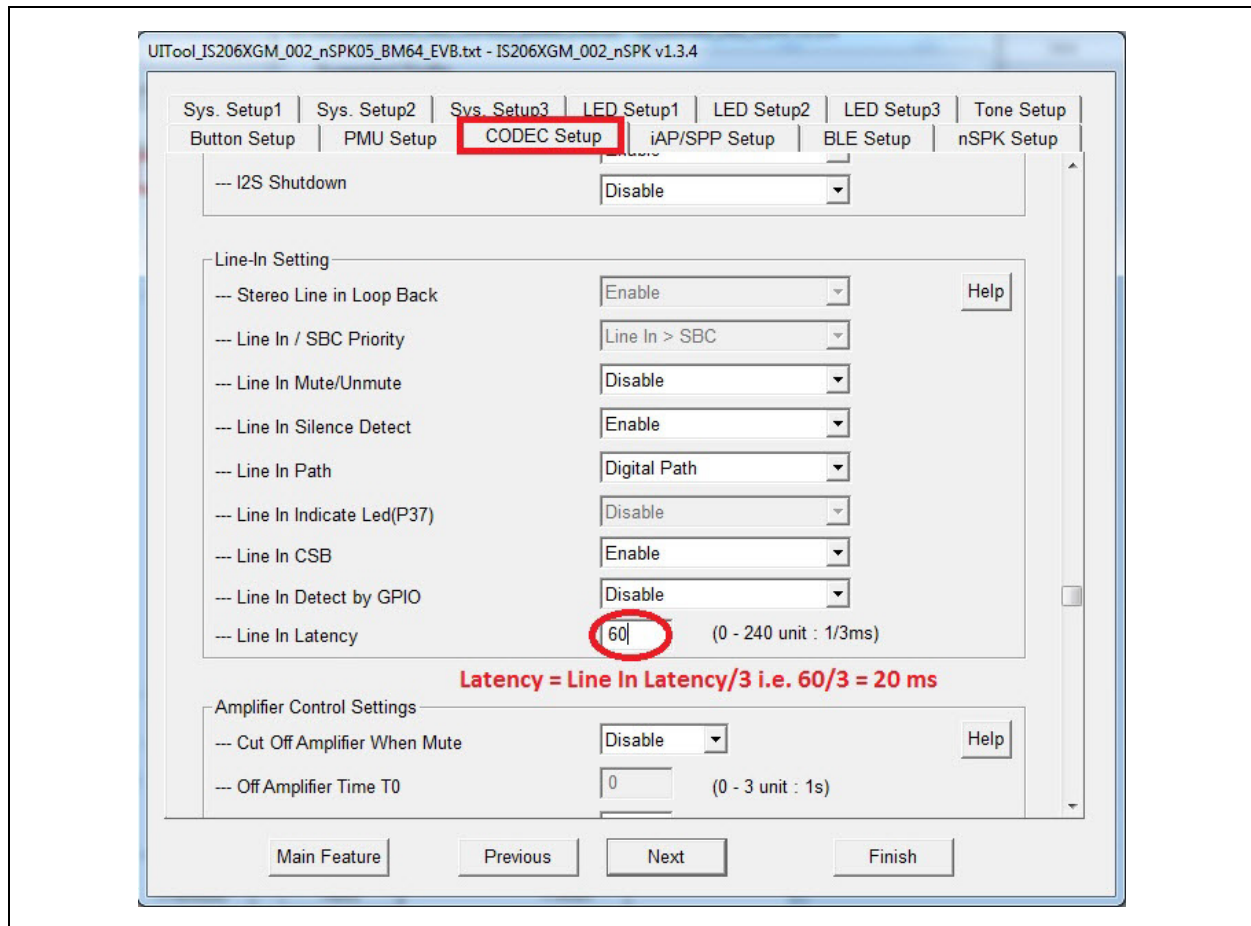

APPENDIX H: REVISION HISTORY

Revision	Description	Date
A	• Initial release	Feb 2018

Note the following details of the code protection feature on Microchip devices:

- Microchip products meet the specification contained in their particular Microchip Data Sheet.
- Microchip believes that its family of products is one of the most secure families of its kind on the market today, when used in the intended manner and under normal conditions.
- There are dishonest and possibly illegal methods used to breach the code protection feature. All of these methods, to our knowledge, require using the Microchip products in a manner outside the operating specifications contained in Microchip's Data Sheets. Most likely, the person doing so is engaged in theft of intellectual property.
- Microchip is willing to work with the customer who is concerned about the integrity of their code.
- Neither Microchip nor any other semiconductor manufacturer can guarantee the security of their code. Code protection does not mean that we are guaranteeing the product as “unbreakable.”

Code protection is constantly evolving. We at Microchip are committed to continuously improving the code protection features of our products. Attempts to break Microchip's code protection feature may be a violation of the Digital Millennium Copyright Act. If such acts allow unauthorized access to your software or other copyrighted work, you may have a right to sue for relief under that Act.

Information contained in this publication regarding device applications and the like is provided only for your convenience and may be superseded by updates. It is your responsibility to ensure that your application meets with your specifications. MICROCHIP MAKES NO REPRESENTATIONS OR WARRANTIES OF ANY KIND WHETHER EXPRESS OR IMPLIED, WRITTEN OR ORAL, STATUTORY OR OTHERWISE, RELATED TO THE INFORMATION, INCLUDING BUT NOT LIMITED TO ITS CONDITION, QUALITY, PERFORMANCE, MERCHANTABILITY OR FITNESS FOR PURPOSE. Microchip disclaims all liability arising from this information and its use. Use of Microchip devices in life support and/or safety applications is entirely at the buyer's risk, and the buyer agrees to defend, indemnify and hold harmless Microchip from any and all damages, claims, suits, or expenses resulting from such use. No licenses are conveyed, implicitly or otherwise, under any Microchip intellectual property rights unless otherwise stated.

Microchip received ISO/TS-16949:2009 certification for its worldwide headquarters, design and wafer fabrication facilities in Chandler and Tempe, Arizona; Gresham, Oregon and design centers in California and India. The Company's quality system processes and procedures are for its PIC® MCUs and dsPIC® DSCs, KEELoQ® code hopping devices, Serial EEPROMs, microperipherals, nonvolatile memory and analog products. In addition, Microchip's quality system for the design and manufacture of development systems is ISO 9001:2000 certified.

**QUALITY MANAGEMENT SYSTEM
CERTIFIED BY DNV
= ISO/TS 16949 =**

Trademarks

The Microchip name and logo, the Microchip logo, AnyRate, AVR, AVR logo, AVR Freaks, BeaconThings, BitCloud, CryptoMemory, CryptoRF, dsPIC, FlashFlex, flexPWR, Heldo, JukeBlox, KEELoQ, KEELoQ logo, Kleer, LANCheck, LINK MD, maXStylus, maXTouch, MediaLB, megaAVR, MOST, MOST logo, MPLAB, OptoLyzer, PIC, picoPower, PICSTART, PIC32 logo, Prochip Designer, QTouch, RightTouch, SAM-BA, SpyNIC, SST, SST Logo, SuperFlash, tinyAVR, UNI/O, and XMEGA are registered trademarks of Microchip Technology Incorporated in the U.S.A. and other countries.

ClockWorks, The Embedded Control Solutions Company, EtherSynch, Hyper Speed Control, HyperLight Load, IntelliMOS, mTouch, Precision Edge, and Quiet-Wire are registered trademarks of Microchip Technology Incorporated in the U.S.A.

Adjacent Key Suppression, AKS, Analog-for-the-Digital Age, Any Capacitor, AnyIn, AnyOut, BodyCom, chipKIT, chipKIT logo, CodeGuard, CryptoAuthentication, CryptoCompanion, CryptoController, dsPICDEM, dsPICDEM.net, Dynamic Average Matching, DAM, ECAN, EtherGREEN, In-Circuit Serial Programming, ICSP, Inter-Chip Connectivity, JitterBlocker, KleerNet, KleerNet logo, Mindi, MiWi, motorBench, MPASM, MPF, MPLAB Certified logo, MPLIB, MPLINK, MultiTRAK, NetDetach, Omniscient Code Generation, PICDEM, PICDEM.net, PICKit, PICtail, PureSilicon, QMatrix, RightTouch logo, REAL ICE, Ripple Blocker, SAM-ICE, Serial Quad I/O, SMART-I.S., SQI, SuperSwitcher, SuperSwitcher II, Total Endurance, TSHARC, USBCheck, VariSense, ViewSpan, WiperLock, Wireless DNA, and ZENA are trademarks of Microchip Technology Incorporated in the U.S.A. and other countries.

SQTP is a service mark of Microchip Technology Incorporated in the U.S.A.

Silicon Storage Technology is a registered trademark of Microchip Technology Inc. in other countries.

GestIC is a registered trademark of Microchip Technology Germany II GmbH & Co. KG, a subsidiary of Microchip Technology Inc., in other countries.

All other trademarks mentioned herein are property of their respective companies.

© 2018, Microchip Technology Incorporated, All Rights Reserved.
ISBN: 978-1-5224-2682-0



MICROCHIP

Worldwide Sales and Service

AMERICAS

Corporate Office
2355 West Chandler Blvd.
Chandler, AZ 85224-6199
Tel: 480-792-7200
Fax: 480-792-7277
Technical Support:
<http://www.microchip.com/support>
Web Address:
www.microchip.com

Atlanta
Duluth, GA
Tel: 678-957-9614
Fax: 678-957-1455

Austin, TX
Tel: 512-257-3370

Boston
Westborough, MA
Tel: 774-760-0087
Fax: 774-760-0088

Chicago
Itasca, IL
Tel: 630-285-0071
Fax: 630-285-0075

Dallas
Addison, TX
Tel: 972-818-7423
Fax: 972-818-2924

Detroit
Novi, MI
Tel: 248-848-4000

Houston, TX
Tel: 281-894-5983

Indianapolis
Noblesville, IN
Tel: 317-773-8323
Fax: 317-773-5453
Tel: 317-536-2380

Los Angeles
Mission Viejo, CA
Tel: 949-462-9523
Fax: 949-462-9608
Tel: 951-273-7800

Raleigh, NC
Tel: 919-844-7510

New York, NY
Tel: 631-435-6000

San Jose, CA
Tel: 408-735-9110
Tel: 408-436-4270

Canada - Toronto
Tel: 905-695-1980
Fax: 905-695-2078

ASIA/PACIFIC

Australia - Sydney
Tel: 61-2-9868-6733

China - Beijing
Tel: 86-10-8569-7000

China - Chengdu
Tel: 86-28-8665-5511

China - Chongqing
Tel: 86-23-8980-9588

China - Dongguan
Tel: 86-769-8702-9880

China - Guangzhou
Tel: 86-20-8755-8029

China - Hangzhou
Tel: 86-571-8792-8115

China - Hong Kong SAR
Tel: 852-2943-5100

China - Nanjing
Tel: 86-25-8473-2460

China - Qingdao
Tel: 86-532-8502-7355

China - Shanghai
Tel: 86-21-3326-8000

China - Shenyang
Tel: 86-24-2334-2829

China - Shenzhen
Tel: 86-755-8864-2200

China - Suzhou
Tel: 86-186-6233-1526

China - Wuhan
Tel: 86-27-5980-5300

China - Xian
Tel: 86-29-8833-7252

China - Xiamen
Tel: 86-592-2388138

China - Zhuhai
Tel: 86-756-3210040

ASIA/PACIFIC

India - Bangalore
Tel: 91-80-3090-4444

India - New Delhi
Tel: 91-11-4160-8631

India - Pune
Tel: 91-20-4121-0141

Japan - Osaka
Tel: 81-6-6152-7160

Japan - Tokyo
Tel: 81-3-6880-3770

Korea - Daegu
Tel: 82-53-744-4301

Korea - Seoul
Tel: 82-2-554-7200

Malaysia - Kuala Lumpur
Tel: 60-3-7651-7906

Malaysia - Penang
Tel: 60-4-227-8870

Philippines - Manila
Tel: 63-2-634-9065

Singapore
Tel: 65-6334-8870

Taiwan - Hsin Chu
Tel: 886-3-577-8366

Taiwan - Kaohsiung
Tel: 886-7-213-7830

Taiwan - Taipei
Tel: 886-2-2508-8600

Thailand - Bangkok
Tel: 66-2-694-1351

Vietnam - Ho Chi Minh
Tel: 84-28-5448-2100

EUROPE

Austria - Wels
Tel: 43-7242-2244-39
Fax: 43-7242-2244-393

Denmark - Copenhagen
Tel: 45-4450-2828
Fax: 45-4485-2829

Finland - Espoo
Tel: 358-9-4520-820

France - Paris
Tel: 33-1-69-53-63-20
Fax: 33-1-69-30-90-79

Germany - Garching
Tel: 49-8931-9700

Germany - Haan
Tel: 49-2129-3766400

Germany - Heilbronn
Tel: 49-7131-67-3636

Germany - Karlsruhe
Tel: 49-721-625370

Germany - Munich
Tel: 49-89-627-144-0
Fax: 49-89-627-144-44

Germany - Rosenheim
Tel: 49-8031-354-560

Israel - Ra'anana
Tel: 972-9-744-7705

Italy - Milan
Tel: 39-0331-742611
Fax: 39-0331-466781

Italy - Padova
Tel: 39-049-7625286

Netherlands - Drunen
Tel: 31-416-690399
Fax: 31-416-690340

Norway - Trondheim
Tel: 47-7289-7561

Poland - Warsaw
Tel: 48-22-3325737

Romania - Bucharest
Tel: 40-21-407-87-50

Spain - Madrid
Tel: 34-91-708-08-90
Fax: 34-91-708-08-91

Sweden - Gothenberg
Tel: 46-31-704-60-40

Sweden - Stockholm
Tel: 46-8-5090-4654

UK - Wokingham
Tel: 44-118-921-5800
Fax: 44-118-921-5820