

---

---

## Hardware Design Checklist

---

---

### 1.0 INTRODUCTION

This document provides a hardware design checklist for the Microchip USB3319. These checklist items should be followed when utilizing the USB3319 in a new design. A summary of these items is provided in [Section 9.0, "Hardware Checklist Summary," on page 13](#). Detailed information on these subjects can be found in the corresponding section:

- [Section 2.0, "General Considerations"](#)
- [Section 3.0, "Power"](#)
- [Section 4.0, "USB"](#)
- [Section 5.0, "Clock Circuit"](#)
- [Section 6.0, "ULPI Interface"](#)
- [Section 7.0, "Startup"](#)
- [Section 8.0, "Miscellaneous"](#)

### 2.0 GENERAL CONSIDERATIONS

#### 2.1 Required References

The USB3319 implementor should have the following documents on hand:

- *USB3319 Data Sheet*
- *AN19.17 ULPI Design Guide*
- *AN18.15 PCB Design Guidelines for QFN and DQFN Packages*
- *AN26.21 USB Device Design Checklist*
- USB 2.0 Specification
- ULPI Specification

#### 2.2 Pin Check

Check the pinout of the part against the data sheet. Ensure that all pins match the data sheet and are configured as inputs, outputs, or bidirectional for error checking.

#### 2.3 Ground

- The ground flag, **GND**, must be connected to the solid ground plane on the board.
- The ground flag is the only circuit ground for power. Other signals that are connected to ground should not be relied upon to provide ground.
- **GND** is also the main path for removing heat from the USB3319. It is therefore important that there are enough vias under the USB3319 connecting it to the ground and that those vias are evenly distributed.
- It is also important that the vias be plugged or vented in such a way as to prevent voids from forming in the solder connection. For details on this topic, see the *AN18.15* and *AN26.21* application notes.

### 3.0 POWER

- USB3319 requires power at:
  - 3.3V for USB analog circuits on **VDD33** pins
  - 1.8V for internal digital circuits on **VDD18** pins

# USB3319

- USB3319 contains internal voltage regulators at 3.3V and 1.8V. The 3.3V regulator is enabled automatically when **VBAT** is supplied. Otherwise, 3.3V must be supplied externally, and the 3.3V regulator is automatically disabled.
    - **VDD18** (pin 21/B3) must have a 0.1  $\mu\text{F}$  filter capacitor attached and connected to ground. One capacitor for both pins is sufficient.
    - **VDD33** (pin 4/D2) must have a 2.2  $\mu\text{F}$  filter capacitor attached if the 3.3V regulator is enabled, having less than 1 $\Omega$  ESR, connected to ground. If the 3.3V regulator is disabled, it should have a 0.1  $\mu\text{F}$  decoupling capacitor attached and connected to ground.
    - **VDD18** and **VDD33** may not be used to supply power to other devices.
  - **VBAT** (pin 3/C2) may be supplied from **VBUS**. In this case, an overvoltage protection should be added to the **VBAT** input for protection from surges on **VBUS**. In addition,  $R_{\text{VBUS}}$  must be added to the **VBUS** input.
- The power and ground connections are shown in [Figure 3-1](#), [Figure 3-2](#), and [Figure 3-3](#).

**FIGURE 3-1: POWER AND GROUND CONNECTIONS, INTERNAL REGULATION**

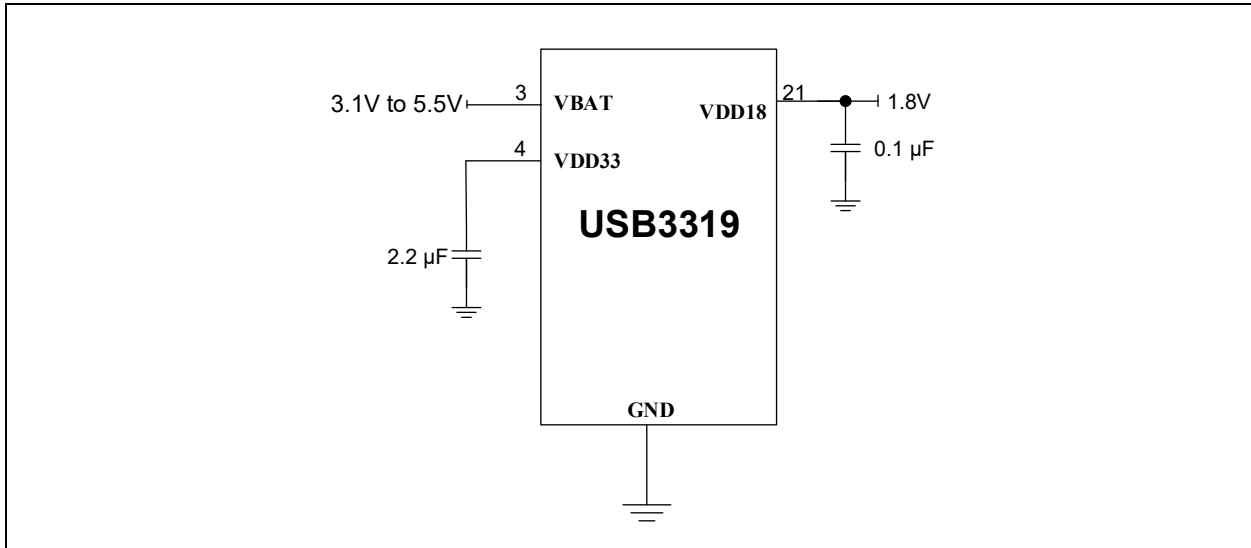

**FIGURE 3-2: POWER AND GROUND CONNECTIONS, EXTERNAL REGULATION**

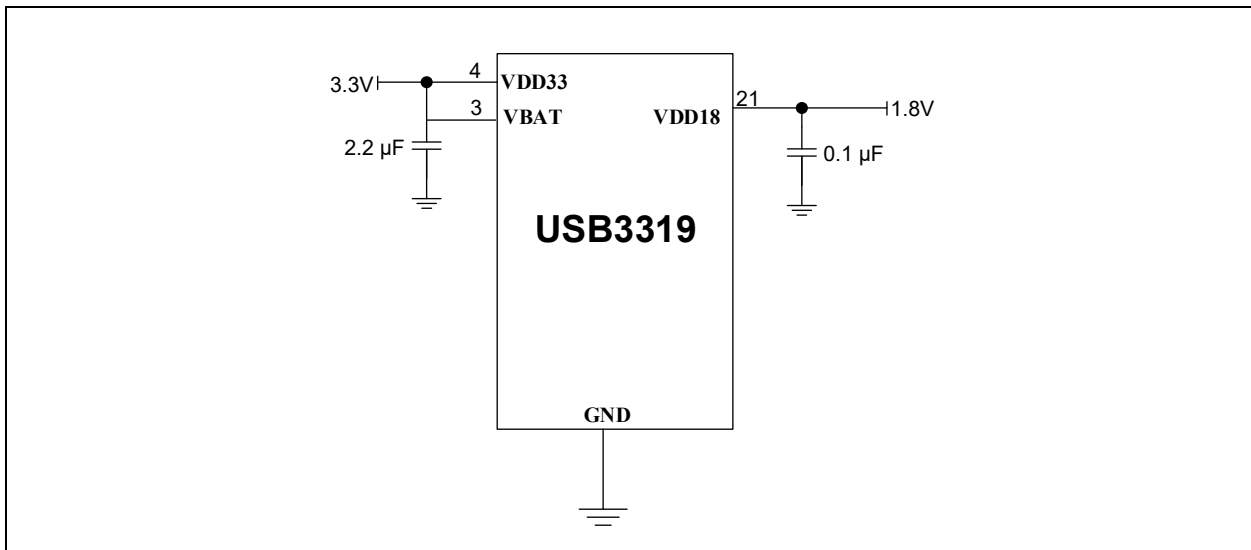

**FIGURE 3-3: POWER AND GROUND CONNECTIONS, VBUS-SUPPLIED**

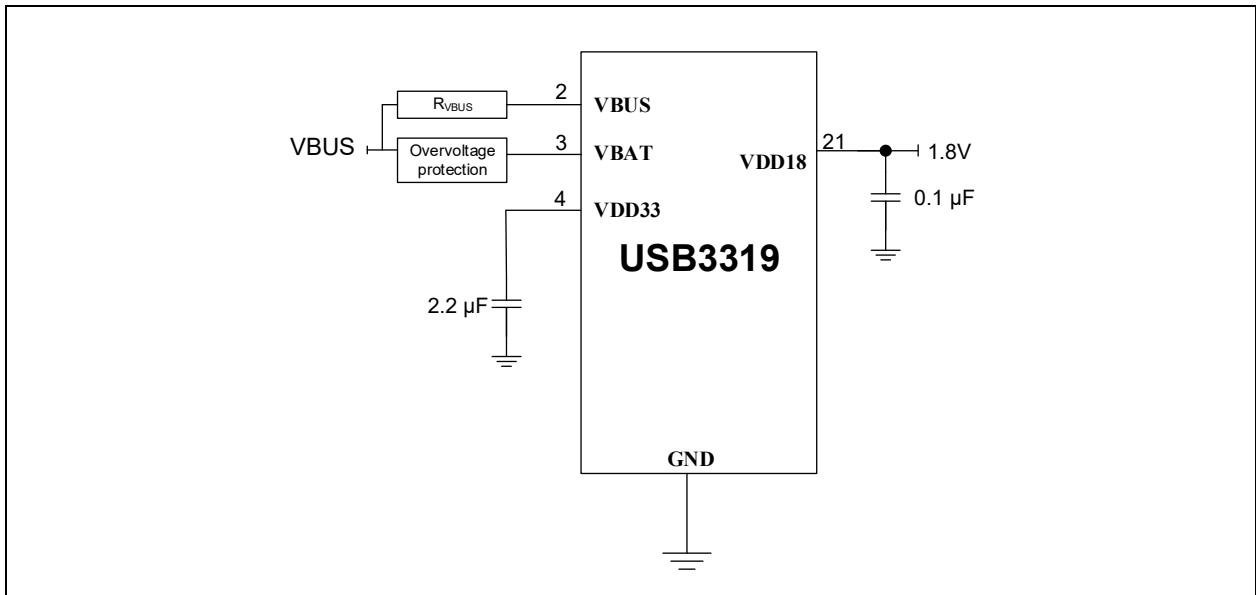

**FIGURE 3-4: VFBGA POWER AND GROUND CONNECTIONS, INTERNAL REGULATION**

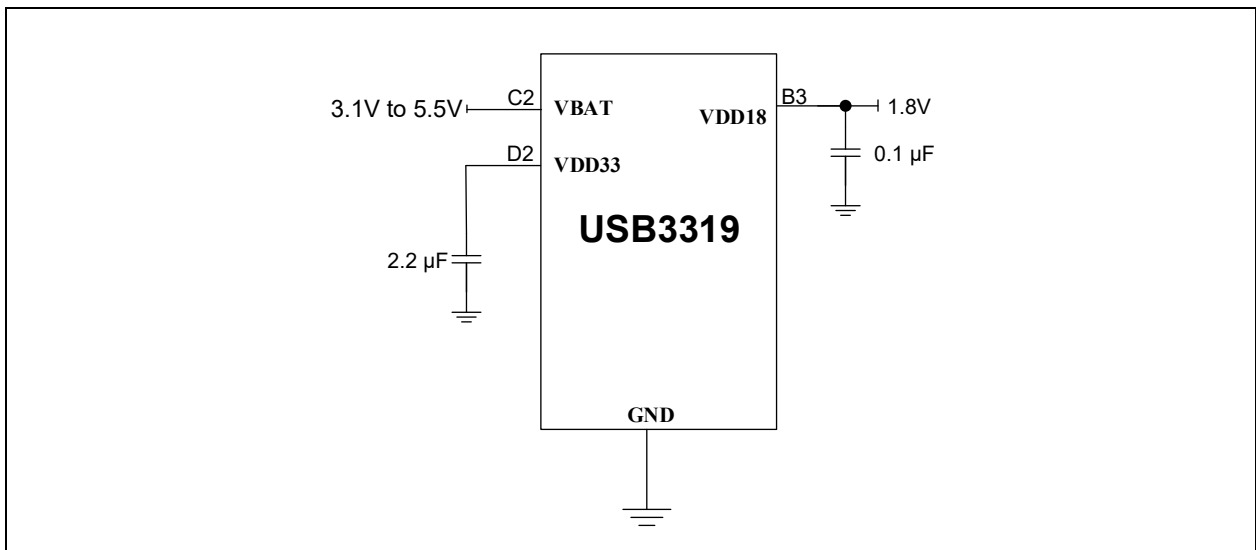

# USB3319

FIGURE 3-5: VFBGA POWER AND GROUND CONNECTIONS, EXTERNAL REGULATION

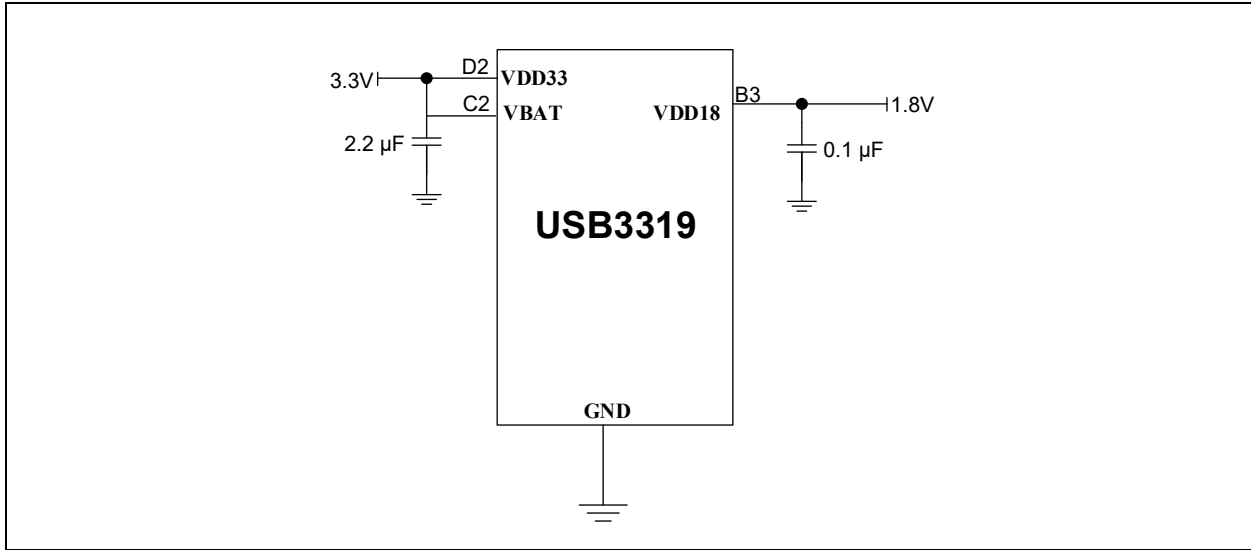
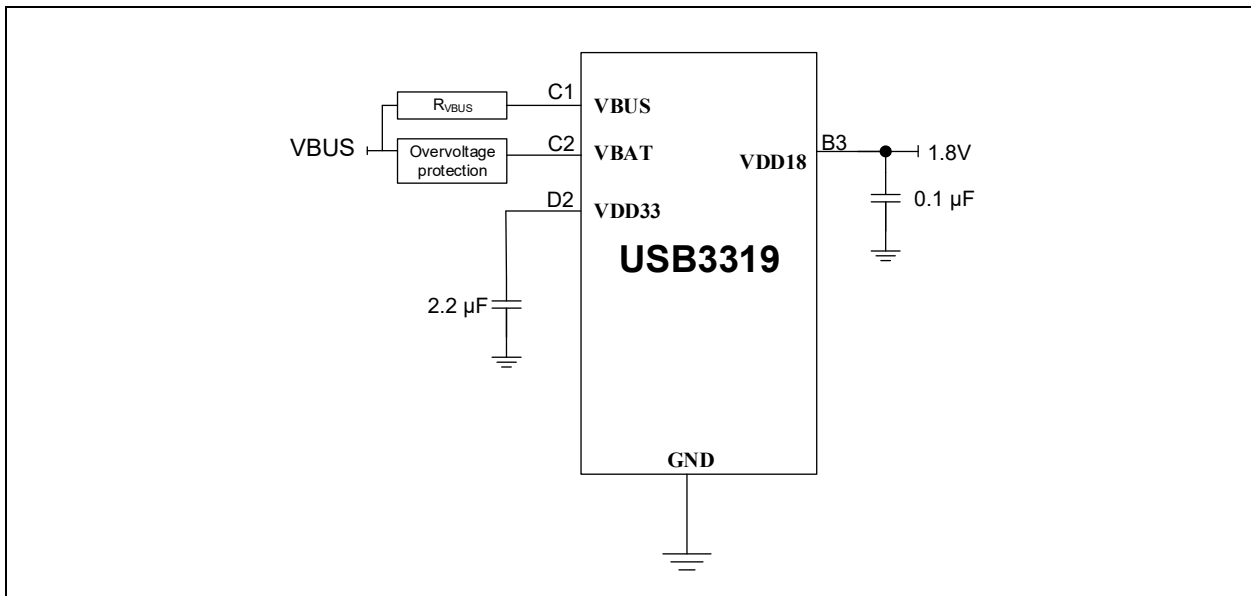

FIGURE 3-6: VFBGA POWER AND GROUND CONNECTIONS, VBUS-SUPPLIED



## 4.0 USB

USB operation is defined by the USB 2.0 Specification. This specification may be obtained from USB Implementers Forum (USB-IF) at [www.usb.org](http://www.usb.org). USB3319 implementors should have a copy of the USB 2.0 Specification and should be familiar with its contents.

The USB3319 can be used for the PHY level of a USB peripheral (device) or a USB host, or a USB On-The-Go (OTG) device (capable as either host or peripheral). The required behaviors of each is defined in the USB 2.0 Specification.

### 4.1 USB Signals

- **DP** (pin 6/E1): This is the positive signal of the USB signal pair.
- **DM** (pin 5/D1): This is the negative signal of the USB signal pair.
  - **DP** and **DM** signals should have controlled impedance. Control the single-ended characteristic impedance ( $Z_0$ ) of USB signals to between  $40\Omega$  and  $55\Omega$ . Control the differential impedance ( $Z_{diff}$ ) of the DP/DM signals to  $90\Omega$ ,  $+5/-10\Omega$ .
- **VBUS** (pin 2/C1): This is the VBUS signal. The USB3319 uses this pin for the VBUS comparator inputs and for VBUS pulsing during session request protocol.
  - $R_{VBUS}$  may be installed in this configuration to assist in protecting the VBUS pin.  $820\Omega$  will protect against VBUS transients up to 8.5V;  $10\text{ k}\Omega$  will protect against transients up to 10V.
  - $C_{VBUS}$  is a transient-suppressing capacitor that is required for USB 2.0 compliance. For a USB 2.0 host, the recommended value for  $C_{VBUS}$  is  $120\ \mu\text{F}$ . For a USB 2.0 device, the recommended value for  $C_{VBUS}$  is  $1\ \mu\text{F}$ .  $C_{VBUS}$  should be located near the USB receptacle and nearer to the receptacle than  $R_{VBUS}$ .
- **ID** (pin 1/B1): This is the ID input, used for USB On-The-Go (OTG) applications. In OTG applications, the ID pin is connected to the ID pin of the OTG-compatible USB Connector and is used to determine the type of USB cable that is connected.
  - When connected to a non-OTG device or an OTG B-Device, this pin floats and is pulled up by an internal resistor.
  - When connected to an OTG A-Device, the ID pin is pulled to the ground by the device.

# USB3319

FIGURE 4-1: USB CONNECTIONS IN A PERIPHERAL APPLICATION

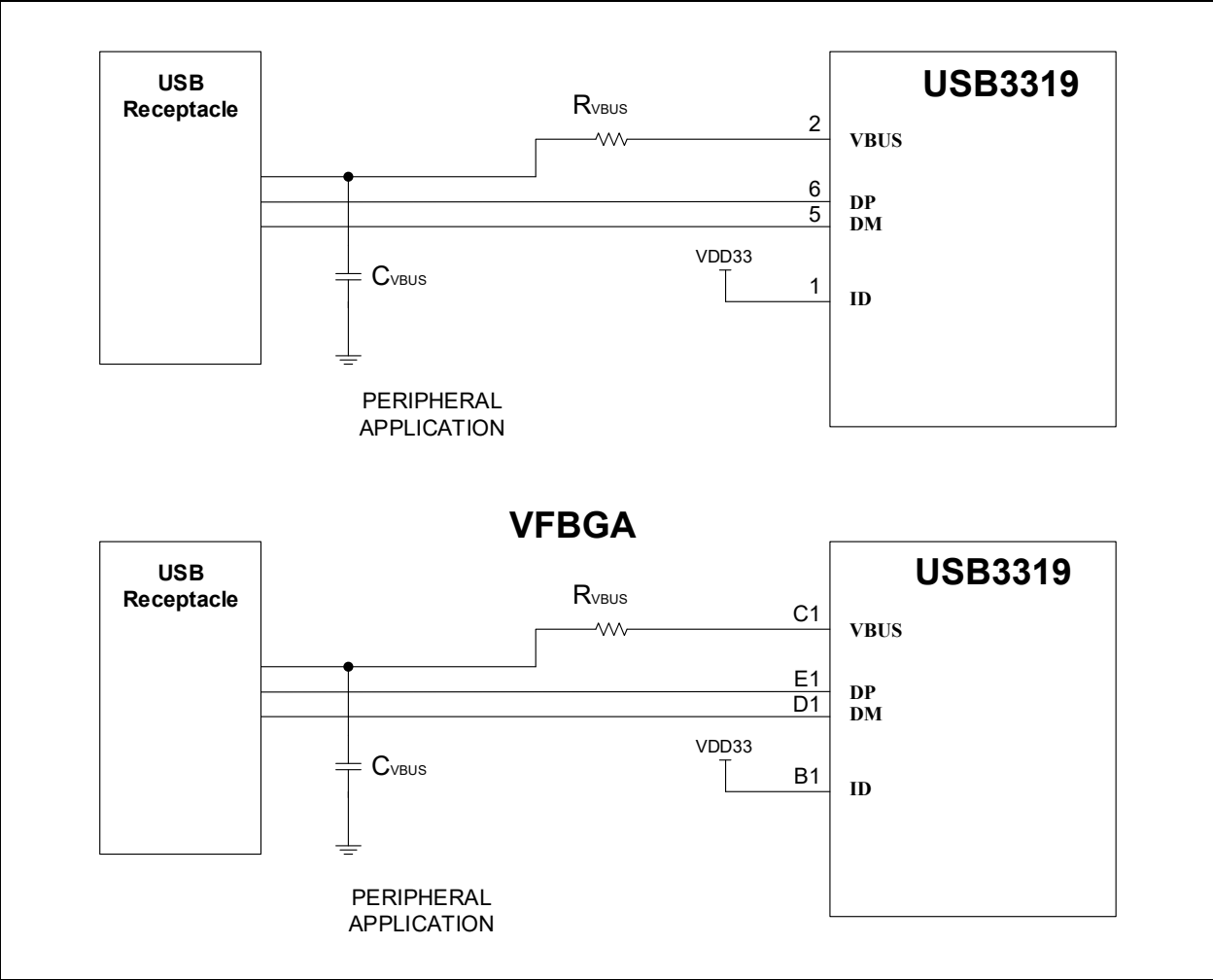

**FIGURE 4-2: USB CONNECTIONS IN A HOST OR OTG APPLICATION**

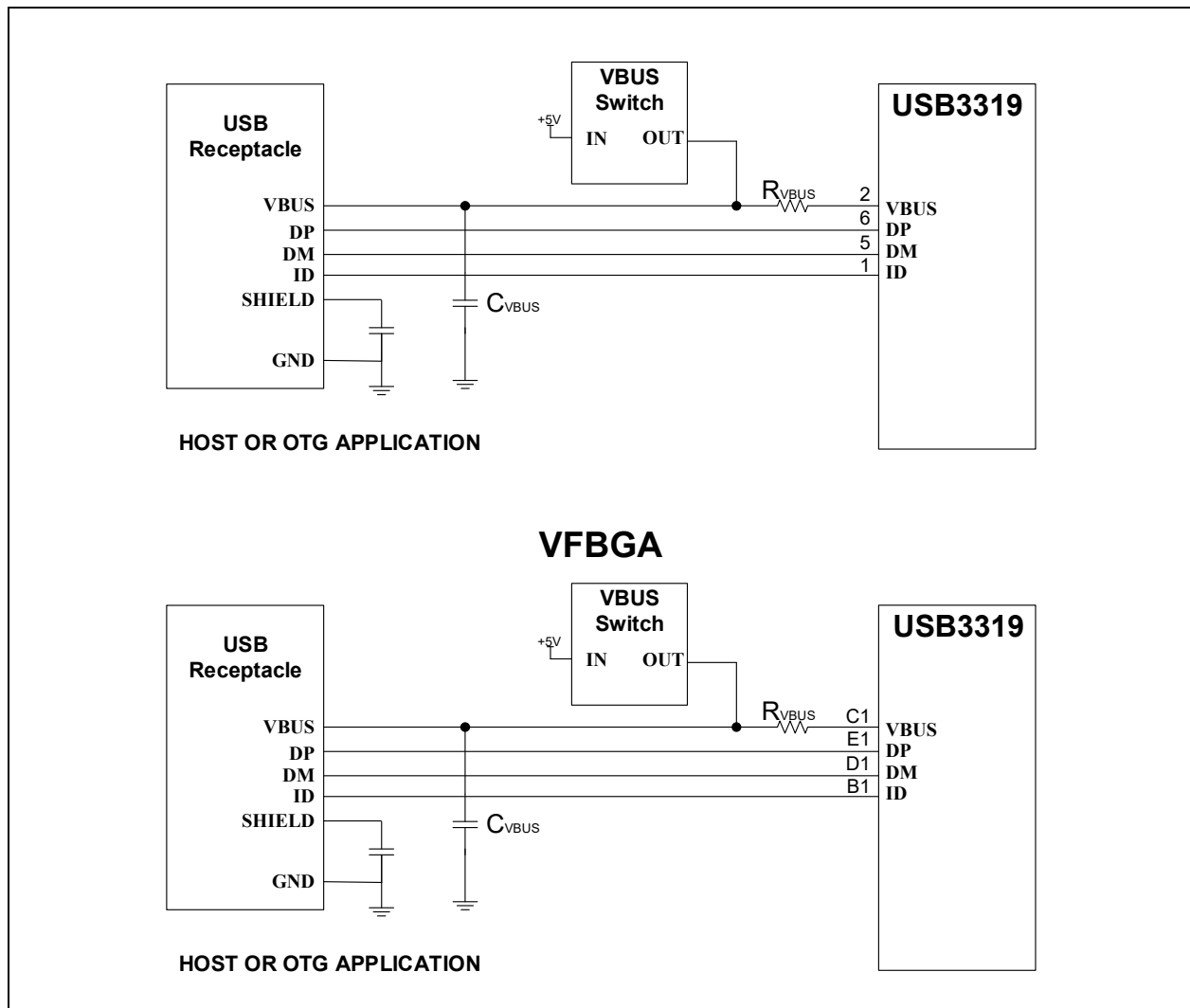

## 4.2 VBUS Switch

USB 2.0 host or OTG applications must be able to provide 5V on VBUS to supply power to USB devices that are attached. The current requirement varies considerably. The USB 2.0 Specification should be consulted for a complete explanation of the VBUS power requirements:

- 100 mA is required for all devices at connection and for low-power bus powered devices.
- 500 mA is required for high-power bus powered devices.
- As much as 5A total may be required for battery charging and other device circuits.

USB3319 supports these requirements by means of an external 5V switch. The VBUS switch connects a 5V supply to VBUS under ULPI register instruction and can detect the current that is supplied through VBUS.

The VBUS switch should feature current detection. To be compliant with the USB 2.0 Specification, the current limit must be no more than 5A.

Factors to consider in selecting a VBUS switch include:

- The current rating of the switch, the current at which the switch asserts the FAULT signal, and the amount of current the system is required to provide
- The capability of the switch to provide protection from reverse currents in the On and Off states

# USB3319

---

The *USB3319 Data Sheet* contains additional detail regarding the operation of an external VBUS switch by the USB3319.

## 4.3 ESD and EMI

The use of external components (diodes, capacitors, and inductors) applied to USB signals is not generally recommended unless there is a specific need for such protection. Such components tend to make USB-IF compliance tests more difficult to pass, which can add time and cost to a project. At the same time, USB3319 is tolerant of protection devices that have been designed specifically for USB 2.0 signal application, and which are guaranteed compliant by their manufacturers.

## 5.0 CLOCK CIRCUIT

### 5.1 ULPI Clock Mode

The USB3319 is designed to operate in one of two available modes: ULPI Input Clock and ULPI Output Clock modes. In the ULPI Input Clock mode, a 60 MHz ULPI clock is driven to the REFCLK pin. In the ULPI Output Clock mode, the USB3319 generates the ULPI clock to the CLKOUT pin. The frequency of the ULPI clock is always 60 MHz.

**FIGURE 5-1: ULPI CLOCK MODE**

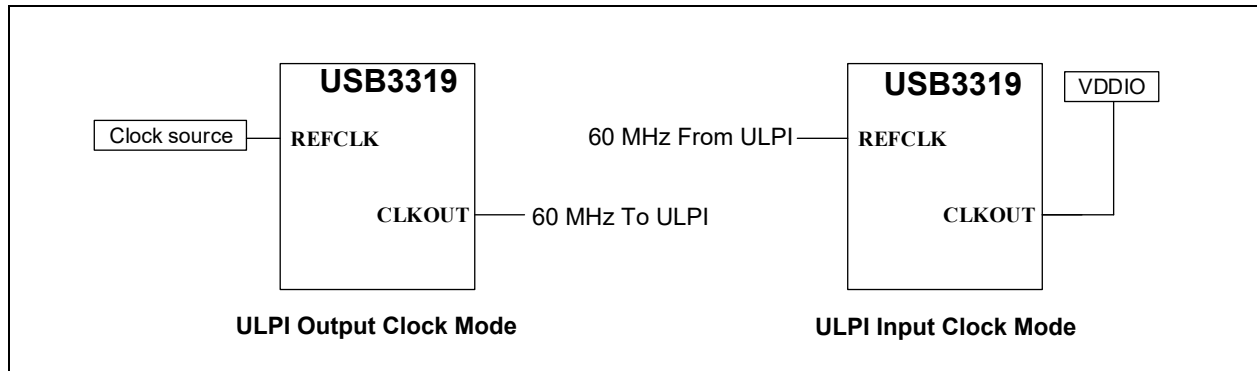

### 5.2 Reference Frequency

The USB3319 can support a 13 MHz crystal oscillator for reference frequency. Alternatively, the USB3319 can receive an external reference frequency. In addition, the USB3319 has the ability to either receive or provide the ULPI clock. When the USB3319 is in the ULPI Input Clock mode, the ULPI clock is applied to REFCLK and the frequency is always 60 MHz.

If a crystal is used, it should be rated for a drive level of at least 500  $\mu$ W.

In ULPI Clock Out mode and implementing a crystal oscillator:

- **REFCLK** (pin 23/A2) is the clock circuit input for the USB3319. This pin requires a capacitor to ground. One side of the crystal connects to this pin.
- Since every system design is unique, the capacitor values are system-dependent, based on the  $C_L$  spec of the crystal and the stray capacitance value. The PCB design, crystal, and layout all contribute to the characteristics of this circuit.

Alternatively, in the ULPI Output Clock mode, a 3.3V clock oscillator may be used to provide the clock source for the USB3319

**FIGURE 5-2: REFCLK AND CLKOUT CONNECTIONS**

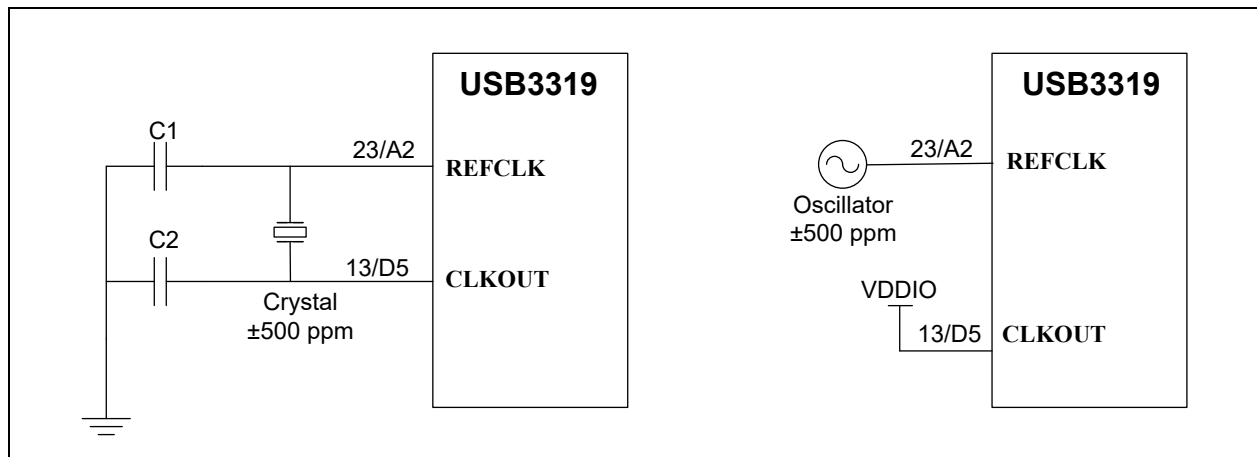

# USB3319

## 6.0 ULPI INTERFACE

- The ULPI interface connects the PHY layer (USB3319) to the LINK layer. The LINK layer consists of an ASIC, FPGA, or other SOC combined with the LINK layer firmware. The ULPI interface is a single-ended, bidirectional bus that operates at 60 MHz.

TABLE 6-1: ULPI SIGNALS

ULPI Signal	Description
DATA[7:0]	Bidirectional data signals
STP	Input from the link layer
DIR	Output to the link layer
NXT	Output to the link layer

FIGURE 6-1: USB3319 ULPI

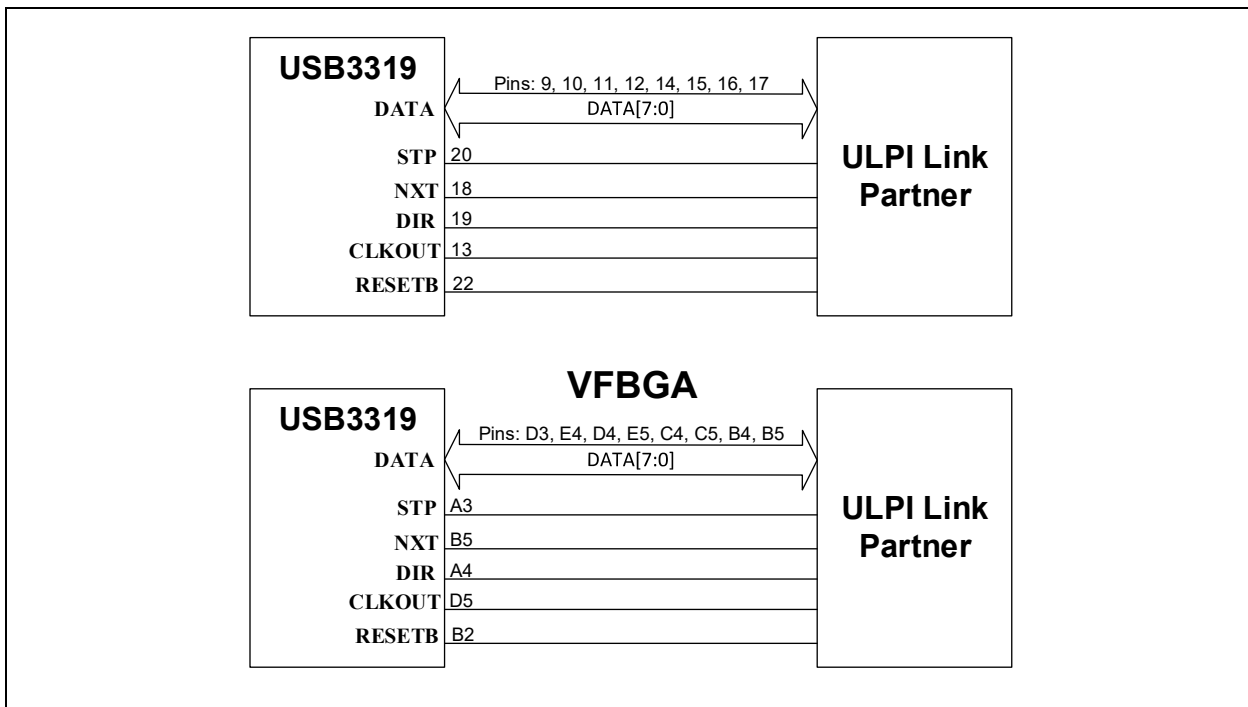

- The ULPI interface is intended to cover short distances between integrated circuits on the same PCB. It is not expected to operate through connectors or a cable.
- ULPI DATA traces should be of similar length, although precisely equal lengths are not required.
- ULPI traces should not have stubs or components to  $V_{CC}$  or ground (such as capacitors).
- ULPI operation is covered in the *USB3319 Data Sheet* and in the *AN19.17* application note.

## 7.0 STARTUP

### 7.1 Reset Circuit

The **RESETB** pin (pin 22/B2) is an active-low transceiver reset. The use of the **RESETB** pin is optional. The state of this pin may be changed asynchronously to the clock signals. When asserted for a minimum of 1 ms and then deasserted, the ULPI registers are reset to their default state and all internal state machines are reset.

The Link must drive the **RESETB** pin to the desired state at all times (including system start-up) or connect the **RESETB** pin to **VDDIO**.

## 8.0 MISCELLANEOUS

### 8.1 RBIAS Resistor

The **RBIAS** pin (pin 24/A1) on the USB3319 must connect to the ground through a 8.06 k $\Omega$  resistor with a tolerance of  $\pm 1.0\%$ . This is essential to the correct setup of critical bias currents.

### 8.2 Connector Selection

The normal connector type selection is based on the role of the USB3319.

- For a host, a Type-A receptacle is used.
- For a device, a Type-B, Mini-B, or Micro-B receptacle is used.
- For a system that implements a Type-C port, either Host or Device mode may be implemented. The system integrator must ensure that the Type-C port role and the mode of operation of the PHY are also in alignment.

For USB 2.0 Specification compliance, the designer should select a USB receptacle to which the USB Integrators Forum has assigned a Test Certification ID (TID). TID numbers that exist for connectors are listed at <https://usb.org/products>.

# USB3319

---

NOTES:

## 9.0 HARDWARE CHECKLIST SUMMARY

TABLE 9-1: HARDWARE DESIGN CHECKLIST

Section	Check	Explanation	√	Notes
Section 2.0, "General Considerations"	Section 2.1, "Required References"	All necessary documents are on hand.		
	Section 2.2, "Pin Check"	The pins match the data sheet.		
Section 3.0, "Power"	Section 3.0, "Power"	Each <b>VDD33</b> pin is supplied between 3.0V and 3.6V.		
		For internal VDD33 regulation, 2.2 $\mu$ F is present on <b>VDD33</b> .		
		For external VDD33 regulation, 2.2 $\mu$ F is present on <b>VDD33</b> .		
		A capacitor of 0.1 $\mu$ F is present on the. <b>VDD18</b> . <b>VDD18</b> is not connected to other devices.		
Section 4.0, "USB"	Section 4.0, "USB"	A copy of the USB 2.0 Specification has been downloaded from www.usb.org.		
	Section 4.1, "USB Signals"	<b>DP</b> and <b>DM</b> are routed with differential impedance of 90 $\Omega$ .		
		<b>DP</b> and <b>DM</b> are routed with single-ended impedance of 40 $\Omega$ -55 $\Omega$ .		
		VBUS is connected to CVBUS of 120 $\mu$ F if host, otherwise 1 $\mu$ F. CVBUS is located near the USB receptacle.		
		VBUS is connected with optional RVBUS no greater than 10 k $\Omega$ .		
	For host, <b>ID</b> pin is connected to the receptacle.			
Section 4.2, "VBUS Switch"	A VBUS switch has been selected according to system requirements.			
Section 5.0, "Clock Circuit"	Section 5.1, "ULPI Clock Mode" and Section 5.2, "Reference Frequency"	For the internal oscillator, the crystal is rated 500 $\mu$ W or greater.		
		For internal oscillator, loading capacitors match the crystal manufacturer specification.		
		For the internal oscillator, the crystal or capacitor traces are short.		
		For external oscillator, crystal frequency is correct per <b>REFSEL</b> settings $\pm$ 500 ppm.		
		For the external oscillator, the signal amplitude is 0V to 3.3V (nominal).		
Section 6.0, "ULPI Interface"	Section 6.0, "ULPI Interface"	ULPI DATA signals are of similar length to the extent practical.		
		ULPI DATA signals have no stubbing (parallel) components connected.		
		No ULPI signal is connected to a header or external connection.		
		ULPI DATA signals do not traverse stubbing vias.		

**TABLE 9-1: HARDWARE DESIGN CHECKLIST (CONTINUED)**

Section	Check	Explanation	√	Notes
Section 7.0, "Startup"	Section 7.1, "Reset Circuit"	If RESET is to be driven, the signal complies with the data sheet, Section 6.1.11.		
		If RESET is not to be driven, the pin is connected to VDD33.		
Section 8.0, "Miscellaneous"	Section 8.0, "Miscellaneous"	RBIAS resistor is 8.06 kΩ ±1.0%.		
		In layout, the ground flag is connected with at least nine vias in a square pattern.		
		In layout, gas blocking or venting techniques have been implemented in the ground flag vias.		
		In layout, the guidance of AN26.21 and AN18.15 has been followed.		
		The USB receptacle has a TID assigned by USB-IF.		

## APPENDIX A: REVISION HISTORY

TABLE A-1: REVISION HISTORY

Revision Level & Date	Section/Figure/Entry	Correction
DS00004452A (03-16-22)	Initial release	

# USB3319

---

## THE MICROCHIP WEB SITE

Microchip provides online support via our WWW site at [www.microchip.com](http://www.microchip.com). This web site is used as a means to make files and information easily available to customers. Accessible by using your favorite Internet browser, the web site contains the following information:

- **Product Support** – Data sheets and errata, application notes and sample programs, design resources, user's guides and hardware support documents, latest software releases and archived software
- **General Technical Support** – Frequently Asked Questions (FAQ), technical support requests, online discussion groups, Microchip consultant program member listing
- **Business of Microchip** – Product selector and ordering guides, latest Microchip press releases, listing of seminars and events, listings of Microchip sales offices, distributors and factory representatives

## CUSTOMER CHANGE NOTIFICATION SERVICE

Microchip's customer notification service helps keep customers current on Microchip products. Subscribers will receive e-mail notification whenever there are changes, updates, revisions or errata related to a specified product family or development tool of interest.

To register, access the Microchip web site at [www.microchip.com](http://www.microchip.com). Under "Support", click on "Customer Change Notification" and follow the registration instructions.

## CUSTOMER SUPPORT

Users of Microchip products can receive assistance through several channels:

- Distributor or Representative
- Local Sales Office
- Field Application Engineer (FAE)
- Technical Support

Customers should contact their distributor, representative or Field Application Engineer (FAE) for support. Local sales offices are also available to help customers. A listing of sales offices and locations is included in the back of this document.

**Technical support is available through the web site at: <http://microchip.com/support>**

---

---

**Note the following details of the code protection feature on Microchip products:**

- Microchip products meet the specifications contained in their particular Microchip Data Sheet.
- Microchip believes that its family of products is secure when used in the intended manner, within operating specifications, and under normal conditions.
- Microchip values and aggressively protects its intellectual property rights. Attempts to breach the code protection features of Microchip product is strictly prohibited and may violate the Digital Millennium Copyright Act.
- Neither Microchip nor any other semiconductor manufacturer can guarantee the security of its code. Code protection does not mean that we are guaranteeing the product is “unbreakable”. Code protection is constantly evolving. Microchip is committed to continuously improving the code protection features of our products.

---

This publication and the information herein may be used only with Microchip products, including to design, test, and integrate Microchip products with your application. Use of this information in any other manner violates these terms. Information regarding device applications is provided only for your convenience and may be superseded by updates. It is your responsibility to ensure that your application meets with your specifications. Contact your local Microchip sales office for additional support or, obtain additional support at <https://www.microchip.com/en-us/support/design-help/client-support-services>.

THIS INFORMATION IS PROVIDED BY MICROCHIP "AS IS". MICROCHIP MAKES NO REPRESENTATIONS OR WARRANTIES OF ANY KIND WHETHER EXPRESS OR IMPLIED, WRITTEN OR ORAL, STATUTORY OR OTHERWISE, RELATED TO THE INFORMATION INCLUDING BUT NOT LIMITED TO ANY IMPLIED WARRANTIES OF NON-INFRINGEMENT, MERCHANTABILITY, AND FITNESS FOR A PARTICULAR PURPOSE, OR WARRANTIES RELATED TO ITS CONDITION, QUALITY, OR PERFORMANCE.

IN NO EVENT WILL MICROCHIP BE LIABLE FOR ANY INDIRECT, SPECIAL, PUNITIVE, INCIDENTAL, OR CONSEQUENTIAL LOSS, DAMAGE, COST, OR EXPENSE OF ANY KIND WHATSOEVER RELATED TO THE INFORMATION OR ITS USE, HOWEVER CAUSED, EVEN IF MICROCHIP HAS BEEN ADVISED OF THE POSSIBILITY OR THE DAMAGES ARE FORESEEABLE. TO THE FULLEST EXTENT ALLOWED BY LAW, MICROCHIP'S TOTAL LIABILITY ON ALL CLAIMS IN ANY WAY RELATED TO THE INFORMATION OR ITS USE WILL NOT EXCEED THE AMOUNT OF FEES, IF ANY, THAT YOU HAVE PAID DIRECTLY TO MICROCHIP FOR THE INFORMATION.

Use of Microchip devices in life support and/or safety applications is entirely at the buyer's risk, and the buyer agrees to defend, indemnify and hold harmless Microchip from any and all damages, claims, suits, or expenses resulting from such use. No licenses are conveyed, implicitly or otherwise, under any Microchip intellectual property rights unless otherwise stated.

**Trademarks**

The Microchip name and logo, the Microchip logo, Adaptec, AnyRate, AVR, AVR logo, AVR Freaks, BesTime, BitCloud, CryptoMemory, CryptoRF, dsPIC, flexPWR, HELDO, IGLOO, JukeBlox, KeeLoq, Klear, LANCheck, LinkMD, maXStylus, maXTouch, MediaLB, megaAVR, Microsemi, Microsemi logo, MOST, MOST logo, MPLAB, OptoLyzer, PIC, picoPower, PICSTART, PIC32 logo, PolarFire, Prochip Designer, QTouch, SAM-BA, SenGenuity, SpyNIC, SST, SST Logo, SuperFlash, Symmetricom, SyncServer, Tachyon, TimeSource, tinyAVR, UNI/O, Vectron, and XMEGA are registered trademarks of Microchip Technology Incorporated in the U.S.A. and other countries.

AgileSwitch, APT, ClockWorks, The Embedded Control Solutions Company, EtherSynch, Flashtec, Hyper Speed Control, HyperLight Load, IntelliMOS, Libero, motorBench, mTouch, Powermite 3, Precision Edge, ProASIC, ProASIC Plus, ProASIC Plus logo, Quiet-Wire, SmartFusion, SyncWorld, Temux, TimeCesium, TimeHub, TimePictra, TimeProvider, TrueTime, WinPath, and ZL are registered trademarks of Microchip Technology Incorporated in the U.S.A.

Adjacent Key Suppression, AKS, Analog-for-the-Digital Age, Any Capacitor, AnyIn, AnyOut, Augmented Switching, BlueSky, BodyCom, CodeGuard, CryptoAuthentication, CryptoAutomotive, CryptoCompanion, CryptoController, dsPICDEM, dsPICDEM.net, Dynamic Average Matching, DAM, ECAN, Espresso T1S, EtherGREEN, GridTime, IdealBridge, In-Circuit Serial Programming, ICSP, INICnet, Intelligent Paralleling, Inter-Chip Connectivity, JitterBlocker, Knob-on-Display, maxCrypto, maxView, memBrain, Mindi, MiWi, MPASM, MPF, MPLAB Certified logo, MPLIB, MPLINK, MultiTRAK, NetDetach, NVMe Express, NVMe, Omniscient Code Generation, PICDEM, PICDEM.net, PICkit, PICtail, PowerSmart, PureSilicon, QMatrix, REAL ICE, Ripple Blocker, RTAX, RTG4, SAM-ICE, Serial Quad I/O, simpleMAP, SimpliPHY, SmartBuffer, SmartHLS, SMART-I.S., storClad, SQI, SuperSwitcher, SuperSwitcher II, Switchtec, SynchroPHY, Total Endurance, TSHARC, USBCheck, VariSense, VectorBlox, VeriPHY, ViewSpan, WiperLock, XpressConnect, and ZENA are trademarks of Microchip Technology Incorporated in the U.S.A. and other countries.

SQTP is a service mark of Microchip Technology Incorporated in the U.S.A.

The Adaptec logo, Frequency on Demand, Silicon Storage Technology, Symmcom, and Trusted Time are registered trademarks of Microchip Technology Inc. in other countries.

GestIC is a registered trademark of Microchip Technology Germany II GmbH & Co. KG, a subsidiary of Microchip Technology Inc., in other countries.

All other trademarks mentioned herein are property of their respective companies.

© 2022, Microchip Technology Incorporated and its subsidiaries.

All Rights Reserved.

ISBN: 978-1-6683-0048-0

For information regarding Microchip's Quality Management Systems, please visit [www.microchip.com/quality](http://www.microchip.com/quality).

---

---



# MICROCHIP

## Worldwide Sales and Service

### AMERICAS

**Corporate Office**  
2355 West Chandler Blvd.  
Chandler, AZ 85224-6199  
Tel: 480-792-7200  
Fax: 480-792-7277  
Technical Support:  
<http://www.microchip.com/support>  
Web Address:  
[www.microchip.com](http://www.microchip.com)

#### Atlanta

Duluth, GA  
Tel: 678-957-9614  
Fax: 678-957-1455

#### Austin, TX

Tel: 512-257-3370

#### Boston

Westborough, MA  
Tel: 774-760-0087  
Fax: 774-760-0088

#### Chicago

Itasca, IL  
Tel: 630-285-0071  
Fax: 630-285-0075

#### Dallas

Addison, TX  
Tel: 972-818-7423  
Fax: 972-818-2924

#### Detroit

Novi, MI  
Tel: 248-848-4000

#### Houston, TX

Tel: 281-894-5983

#### Indianapolis

Noblesville, IN  
Tel: 317-773-8323  
Fax: 317-773-5453  
Tel: 317-536-2380

#### Los Angeles

Mission Viejo, CA  
Tel: 949-462-9523  
Fax: 949-462-9608  
Tel: 951-273-7800

#### Raleigh, NC

Tel: 919-844-7510

#### New York, NY

Tel: 631-435-6000

#### San Jose, CA

Tel: 408-735-9110  
Tel: 408-436-4270

#### Canada - Toronto

Tel: 905-695-1980  
Fax: 905-695-2078

### ASIA/PACIFIC

**Australia - Sydney**  
Tel: 61-2-9868-6733

**China - Beijing**  
Tel: 86-10-8569-7000

**China - Chengdu**  
Tel: 86-28-8665-5511

**China - Chongqing**  
Tel: 86-23-8980-9588

**China - Dongguan**  
Tel: 86-769-8702-9880

**China - Guangzhou**  
Tel: 86-20-8755-8029

**China - Hangzhou**  
Tel: 86-571-8792-8115

**China - Hong Kong SAR**  
Tel: 852-2943-5100

**China - Nanjing**  
Tel: 86-25-8473-2460

**China - Qingdao**  
Tel: 86-532-8502-7355

**China - Shanghai**  
Tel: 86-21-3326-8000

**China - Shenyang**  
Tel: 86-24-2334-2829

**China - Shenzhen**  
Tel: 86-755-8864-2200

**China - Suzhou**  
Tel: 86-186-6233-1526

**China - Wuhan**  
Tel: 86-27-5980-5300

**China - Xian**  
Tel: 86-29-8833-7252

**China - Xiamen**  
Tel: 86-592-2388138

**China - Zhuhai**  
Tel: 86-756-3210040

### ASIA/PACIFIC

**India - Bangalore**  
Tel: 91-80-3090-4444

**India - New Delhi**  
Tel: 91-11-4160-8631

**India - Pune**  
Tel: 91-20-4121-0141

**Japan - Osaka**  
Tel: 81-6-6152-7160

**Japan - Tokyo**  
Tel: 81-3-6880-3770

**Korea - Daegu**  
Tel: 82-53-744-4301

**Korea - Seoul**  
Tel: 82-2-554-7200

**Malaysia - Kuala Lumpur**  
Tel: 60-3-7651-7906

**Malaysia - Penang**  
Tel: 60-4-227-8870

**Philippines - Manila**  
Tel: 63-2-634-9065

**Singapore**  
Tel: 65-6334-8870

**Taiwan - Hsin Chu**  
Tel: 886-3-577-8366

**Taiwan - Kaohsiung**  
Tel: 886-7-213-7830

**Taiwan - Taipei**  
Tel: 886-2-2508-8600

**Thailand - Bangkok**  
Tel: 66-2-694-1351

**Vietnam - Ho Chi Minh**  
Tel: 84-28-5448-2100

### EUROPE

**Austria - Wels**  
Tel: 43-7242-2244-39  
Fax: 43-7242-2244-393

**Denmark - Copenhagen**  
Tel: 45-4485-5910  
Fax: 45-4485-2829

**Finland - Espoo**  
Tel: 358-9-4520-820

**France - Paris**  
Tel: 33-1-69-53-63-20  
Fax: 33-1-69-30-90-79

**Germany - Garching**  
Tel: 49-8931-9700

**Germany - Haan**  
Tel: 49-2129-3766400

**Germany - Heilbronn**  
Tel: 49-7131-72400

**Germany - Karlsruhe**  
Tel: 49-721-625370

**Germany - Munich**  
Tel: 49-89-627-144-0  
Fax: 49-89-627-144-44

**Germany - Rosenheim**  
Tel: 49-8031-354-560

**Israel - Ra'anana**  
Tel: 972-9-744-7705

**Italy - Milan**  
Tel: 39-0331-742611  
Fax: 39-0331-466781

**Italy - Padova**  
Tel: 39-049-7625286

**Netherlands - Drunen**  
Tel: 31-416-690399  
Fax: 31-416-690340

**Norway - Trondheim**  
Tel: 47-7288-4388

**Poland - Warsaw**  
Tel: 48-22-3325737

**Romania - Bucharest**  
Tel: 40-21-407-87-50

**Spain - Madrid**  
Tel: 34-91-708-08-90  
Fax: 34-91-708-08-91

**Sweden - Gothenberg**  
Tel: 46-31-704-60-40

**Sweden - Stockholm**  
Tel: 46-8-5090-4654

**UK - Wokingham**  
Tel: 44-118-921-5800  
Fax: 44-118-921-5820