

High Voltage Amplifier Array

General Description

The Supertex HV256DB1 is a 32-Channel 295V amplifier array with a nominal gain of 72V/V. The purpose of the HV256DB1 is to provide a means to easily evaluate the Supertex HV256FG device. A high voltage supply, V_{PP} , and two low voltage supplies, V_{DD} and V_{NN} , are required. These connections can be made via the J1 header provided on the board. There are 32 pads on the left side of the board for the input signals and 32 pads on the right for the outputs. Be sure to follow the power up/down sequence to avoid damaging the device.

Specifications

Parameter	Value
V_{PP} , High voltage supply:	300V
V_{DD} , Low voltage positive supply	6.0 to 7.5V
V_{NN} , Low voltage negative supply	-4.5 to -6.5V
V_{IN} , Input signal range:	0 to 5.0V
HV_{OUT} , Output voltage swing	0 to 295V
A_v , Closed loop gain	72V/V \pm 5%
SR, Output slew rate into 100pF load	2.0V/ μ s

Board Layout and Connections

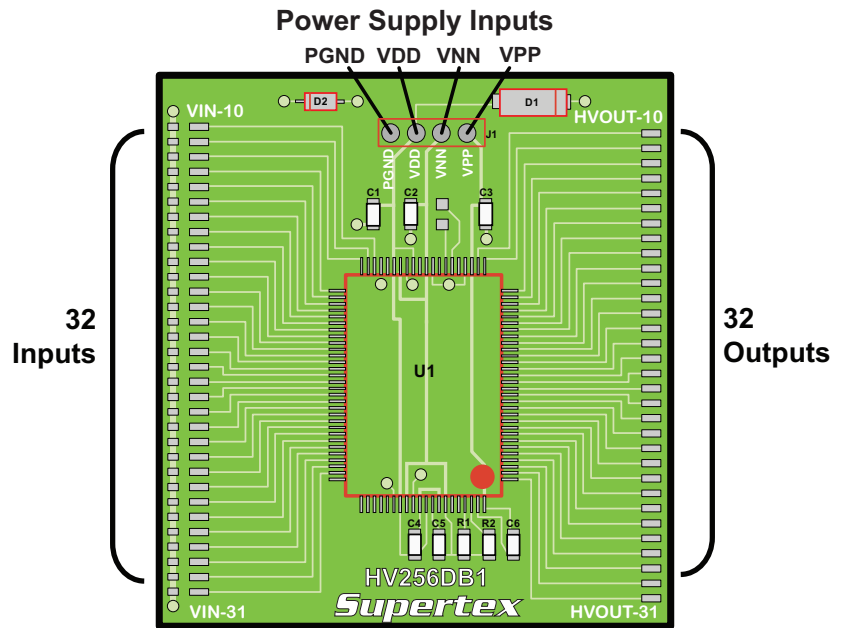
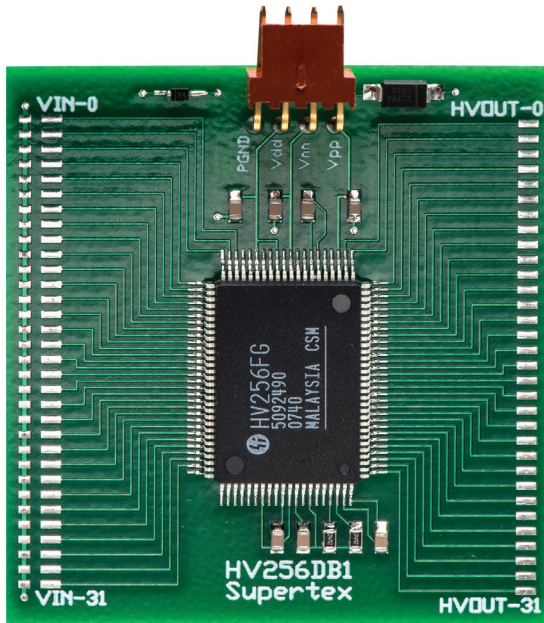

Power Up/Down Sequence

The device can be damaged due to improper power up/down sequence. To prevent damage, please follow the acceptable power up/down sequences. Two external diodes, D1 and D2, are added in the demo board to prevent damage during power Up/Down. The first diode is a high voltage diode across V_{PP} and V_{DD} . Any low current high voltage diode can be used. The second diode can be any low voltage schottky diode across V_{NN} and GND.

Acceptable Power Up Sequences

- 1) V_{PP} 2) V_{NN} 3) V_{DD} 4) Inputs & Anode
- or
- 1) V_{NN} 2) V_{DD} 3) V_{PP} 4) Inputs & Anode

Acceptable Power Down Sequences

- 1) Inputs & Anode 2) V_{PP} 3) V_{DD} 4) V_{NN}
- or
- 1) Inputs & Anode 2) V_{DD} 3) V_{NN} 4) V_{PP}

Inputs and Outputs

The output of the HV256FG will swing from 0 to 295V. The internal closed loop gain is set at 72V/V. An input voltage of 4.096V will give an output of 295V. Input voltages of up to 5.0V can be applied but will cause the amplifier to saturate.

The output current source and sink for all 32 channels can be adjusted using R1 and R2. The limit is approximately 12.5V divided by the resistor value. The demo board uses 24.9k Ω for \pm 500uA limiting.

Temperature Diode

The HV256FG has an integrated silicon diode to help monitor the die temperature if desired. Pin 37 is the anode

and pin 36 is the cathode. Pads are available on the board for these connections.

Circuit Diagram

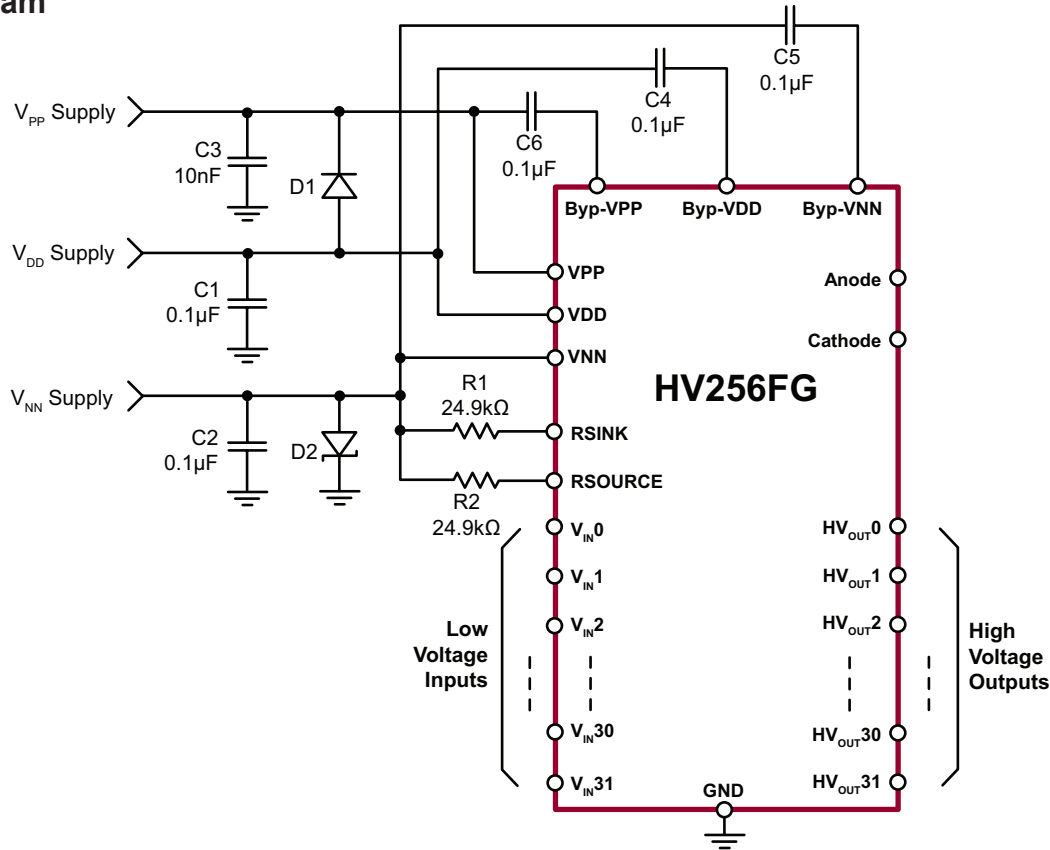

Bill of Materials

Part	Description	Value	Package	Manufacturer	Part Number
C1	X7R chip capacitor	25V, 0.1µF±10%	0805	Tecate	CMC-025104KX0805T
C2	X7R chip capacitor	25V, 0.1µF±10%	0805	Tecate	CMC-025104KX0805T
C3	X7R chip capacitor	500V, 0.01µF±10%	0805	Tecate	CMC-500103KX0805T
C4	X7R chip capacitor	25V, 0.1µF±10%	0805	Tecate	CMC-025104KX0805T
C5	X7R chip capacitor	25V, 0.1µF±10%	0805	Tecate	CMC-025104KX0805T
C6	X7R chip capacitor	25V, 0.1µF±10%	0805	Tecate	CMC-025104KX0805T
R1	Chip resistor	24.9kΩ, ±1%	0805	Any	---
R2	Chip resistor	24.9kΩ, ±1%	0805	Any	---
D1	Rectifier diode	400V, 1.0A	SMA	Diodes Inc	US1G
D2	Schottky diode	20V, 1.0A	SOD-323	Diodes Inc	SD103CWS
U1	Amplifier array	300V	100-Lead MQFP	Supertex	HV256FG
J1	Right Angle 4-pin header	0.100", tin plating	---	Molex	22-05-3041

Supertex inc. does not recommend the use of its products in life support applications, and will not knowingly sell them for use in such applications unless it receives an adequate "product liability indemnification insurance agreement." **Supertex inc.** does not assume responsibility for use of devices described, and limits its liability to the replacement of the devices determined defective due to workmanship. No responsibility is assumed for possible omissions and inaccuracies. Circuitry and specifications are subject to change without notice. For the latest product specifications refer to the **Supertex inc.** (website: <http://www.supertex.com>)