Hardware Design Checklist

1.0 INTRODUCTION

This document provides a hardware design checklist for the Microchip USB2660. These checklist items should be followed when utilizing the USB2660 in a new design. A summary of these items is provided in [Section 9.0, "Hardware Checklist Summary," on page 21](#). Detailed information on these subjects can be found in the corresponding section:

- [Section 2.0, "General Considerations"](#)
- [Section 3.0, "Power"](#)
- [Section 4.0, "USB Signals"](#)
- [Section 5.0, "Card Reader Interface"](#)
- [Section 6.0, "Clock Circuit"](#)
- [Section 7.0, "Power and Startup"](#)
- [Section 8.0, "Configuration Options"](#)

2.0 GENERAL CONSIDERATIONS

2.1 Required References

The USB2660 implementor should have the following documents on hand:

- *USB2660 Data Sheet* (www.microchip.com/DS00001931)
- USB2.0 Specification
- MultiMediaCard™ 4.2 Specification
- Secure Digital™ 2.0 Specification
- Other references on the product page at www.microchip.com

2.2 Pin Check

Check the pinout of the part against the data sheet. Ensure that all pins match the data sheet and are configured as inputs, outputs, or bidirectional for error checking.

2.3 Ground

- The ePad, VSS, should be connected to the solid ground plane on the board.
- It is recommended that all ground connections be tied together to the same ground plane. Separate ground planes are not recommended.

2.4 USB-IF-Compliant USB Connector

- USB-IF-certified USB Connector with a valid Test ID (TID) is required for all USB products to be compliant and pass USB-IF product certification.

USB2660

3.0 POWER

- The 3.3V supply (**VDD33**) is the analog and digital domain power supply inputs. They are located on pins 5, 14, 24, 33, 42, 47, 57 and 64. These pins all require a connection to a regulated 3.3V power plane and each should include 0.1 μF capacitors to decouple the device. The capacitor size should be SMD_0603 or smaller.
- Pins 24 and 64 (**VDD33**) each also require a 4.7 μF bulk capacitor.
- Pin 62 (**PLLFILT**) is a power bypass for the PLL and should connect to an external filter capacitor. A 1.0 μF capacitor is recommended. Do not power external circuitry from this regulator output.
- Pin 23 (**CRFILT**) is a digital core regulator output and should connect to an external filter capacitor. A 1.0 μF capacitor is recommended. Do not power external circuitry from this regulator output.

The power and ground connections are shown in [Figure 3-1](#).

FIGURE 3-1: POWER AND GROUND CONNECTIONS

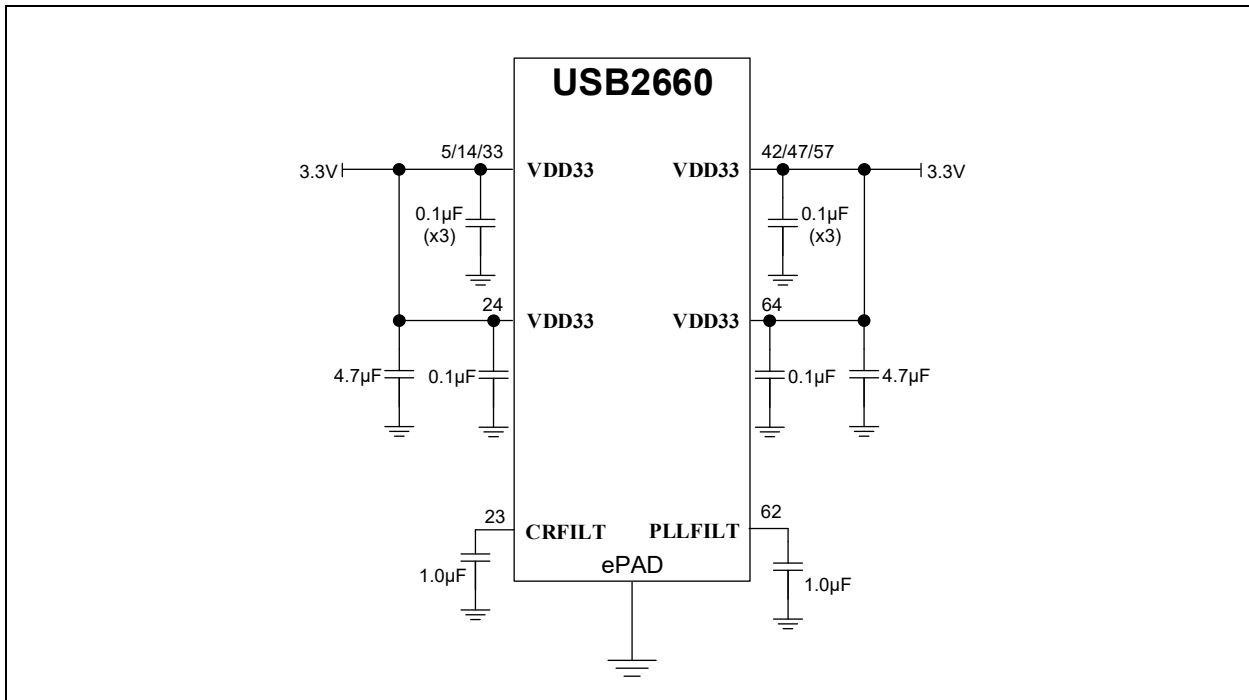

4.0 USB SIGNALS

4.1 USB Interface

- **USB+** (pin 58): This pin is the positive (+) signal of the upstream USB2.0 differential pair. All necessary USB terminations and resistors are included in the IC. This pin can connect directly to the D+/DP pin of a USB connector.
- **USB-** (pin 59): This pin is the negative (-) signal of the upstream USB2.0 differential pair. All necessary USB terminations and resistors are included in the IC. This pin can connect directly to the D-/DM pin of a USB connector.
- **VBUS_DET** (pin 55): This pin is used to detect the presence of a USB host. Since a standard VBUS supply is nominally 5V, VBUS must be divided down to a voltage level the pin can accept. The **VBUS_DET** pin uses 3.3V logic levels, so a resistor divider consisting of two 100 k Ω resistors is generally recommended, although precise values are not critical as long as logical high is presented to the pin when a valid VBUS voltage is present on the USB connector.
 - Optionally, an additional capacitor and/or ferrite bead between the **VBUS** pin of the USB connector and the **VBUS_DET** pin provides some immunity to the device from noise/transients on the VBUS line. It is generally recommended to design in extra population options for series and parallel components, which may be added to the system if additional components are deemed necessary during system testing or qualification.

For transmit and receive channel connection details, refer to [Figure 4-1](#).

FIGURE 4-1: USB DATA SIGNAL CONNECTIONS

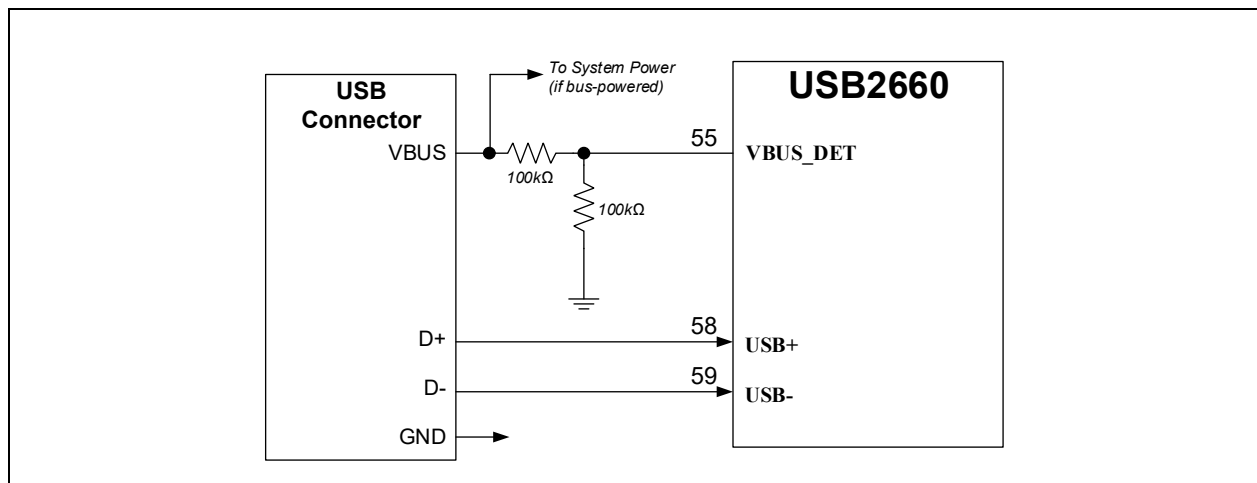

4.2 Downstream USB Ports

4.2.1 USB PHY INTERFACE

- **USBDN_DP_x** (pins 2 and 4): These pins are the positive (+) signals of the downstream ports 2 and 3 USB2.0 differential pairs. All necessary USB terminations and resistors are included in the IC. These pins can connect directly to the D+/DP pin of a USB connector.
- **USBDN_DM_x** (pins 1 and 3): These pins are the negative (-) signals of the downstream ports 2 and 3 USB2.0 differential pairs. All necessary USB terminations and resistors are included in the IC. These pins can connect directly to the D-/DM pin of a USB connector.

Note: The polarity of any of the USB2.0 differential pairs may be inverted either intentionally due to design constraints or to correct a design error using the Microchip PortSwap feature. This feature may be configured via SMBus/I²C configuration registers.

USB2660

For transmit and receive channel connection details, refer to [Figure 4-2](#).

FIGURE 4-2: USB DOWNSTREAM PORT DATA SIGNAL CONNECTIONS

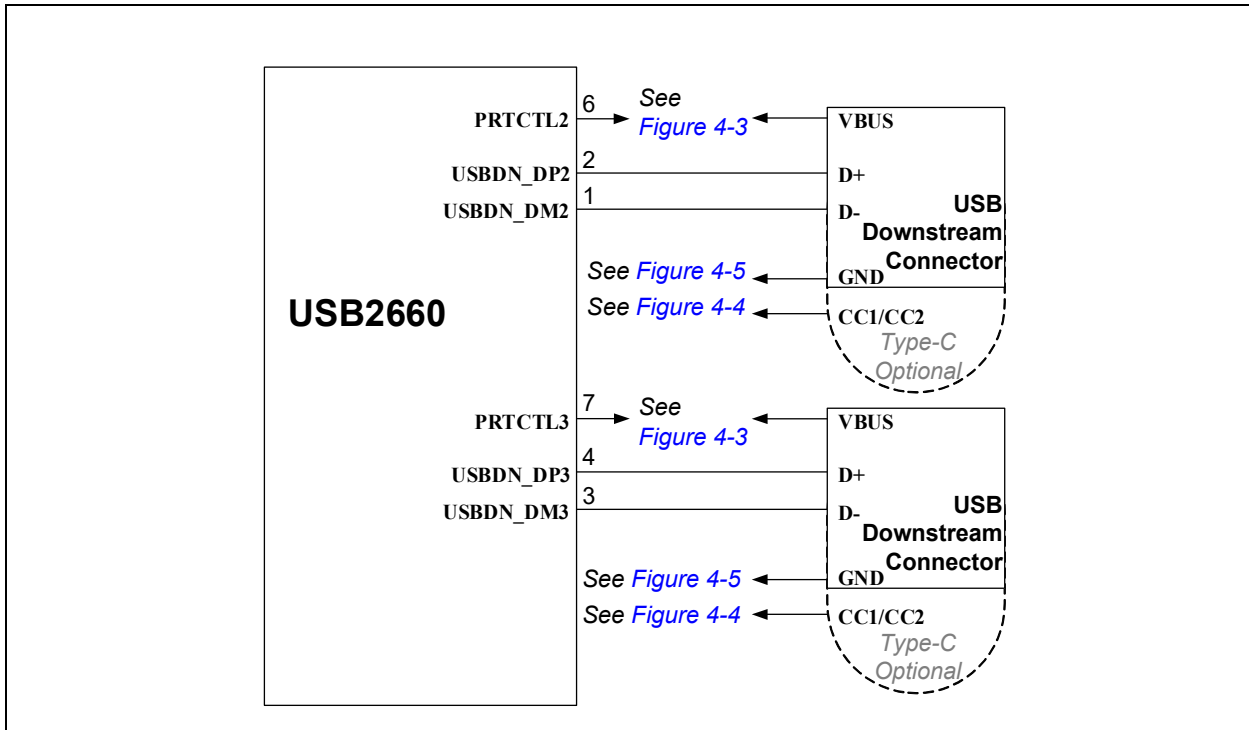

4.2.2 DISABLE DOWNSTREAM PORTS IF UNUSED

If any downstream port of the USB2660 is unused, it should be disabled. This can be achieved through hub configuration (I²C) or through a port disable strap option.

4.2.3 DOWNSTREAM PORT CONTROL SIGNALS (PRTCTLX)

The PRTCTL_x pin is an output pin that has the following states:

- **PORT OFF:** PRTCTL_x is an output and drives low. The PRTCTL_x pin will only transition to the PORT ON state through a specific command from the USB host.
- **PORT ON:** PRTCTL_x enables internal pull-up resistor and switches to Input mode. While in this state, the input buffer monitors for overcurrent events. An overcurrent event is detected if the state of the pin is detected as low (below the V_{ILI} voltage). The port moves to the PORT OFF state after one of the following events:
 - An overcurrent event is sensed when the state of the pin is detected as low (below the V_{ILI} voltage).
 - A command from the USB host is received that instructs the hub to disable power.
 - The hub is reset or experiences a POR event.

To ensure minimal BOM cost and simplicity, select a port power controller device with a 3.3V logic level, active-high enable input, and an open-drain, active-low fault indication output signal. If a device that operates from a 5V logic level is selected, the PRTCTL_x signal may need to be boosted using external logic. If a port power controller with active low input is selected, the PRTCTL_x signal needs to be inverted using external logic.

A typical VBUS port power control implementation is shown in [Figure 4-3](#).

FIGURE 4-3: DOWNSTREAM VBUS AND PRTCTL1 CONNECTIONS

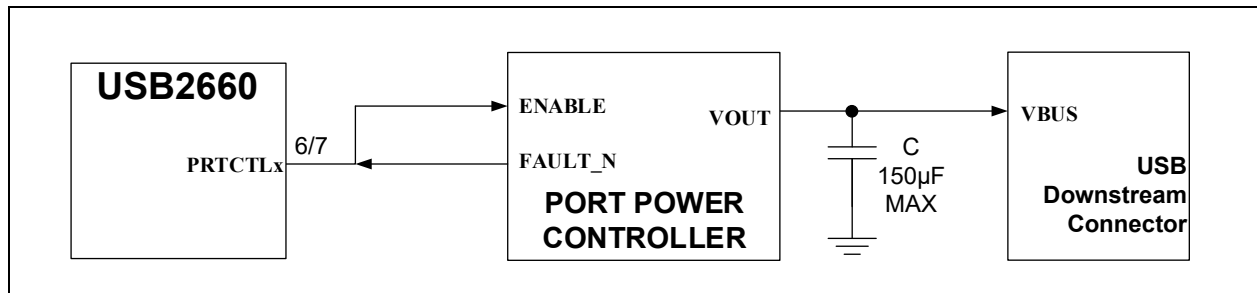

Note: The implementation as shown in [Figure 4-3](#) assumes that the port power controller has an active-high enable input, and an active-low, open-drain style fault indicator. External polarity inversion through buffers or FETs may be required if the port power controller has different I/O characteristics.

4.2.4 DOWNSTREAM PORT TYPE-C SUPPORT

Note: It is not possible to implement a USB Type-C downstream port that is compliant to all USB Type-C specification without utilizing a Type-C port controller device. The required functionality is not practical to achieve solely using discrete analog circuitry.

The USB2660 may be used with Type-C as the downstream port. This requires a Type-C port controller or combined port power controller and Type-C port controller. The USB2660 simply controls the Type-C port controller in same way it would control a standard Type-A port power controller. The USB2660 does not require any kind of Type-C port status information from the Type-C port controller. The PRTCTLx signal should be connected to an enable pin on the Type-C controller, and the fault indicator output of the port power controller should connect back to the PRTCTLx signal as well.

If the Type-C controller and the port power controller are separate devices; the Type-C controller must control the Enable pin of the port power controller switch supplying VBUS to the connection. The PRTCTLx should not directly control the VBUS enable signal of the port power controller.

A Type-C controller may be configured to signal a 500 mA, 1.5A, or 3.0A port power capability. (However, per the USB specification, Type-C ports may not advertise a 500 mA capability. That power level is reserved for legacy port cable adapters alone). The selected port power controller should be sized accordingly.

A typical implementation is shown in [Figure 4-4](#).

FIGURE 4-4: DOWNSTREAM VBUS AND PRTCTL1 CONNECTIONS WITH A TYPE-C PORT

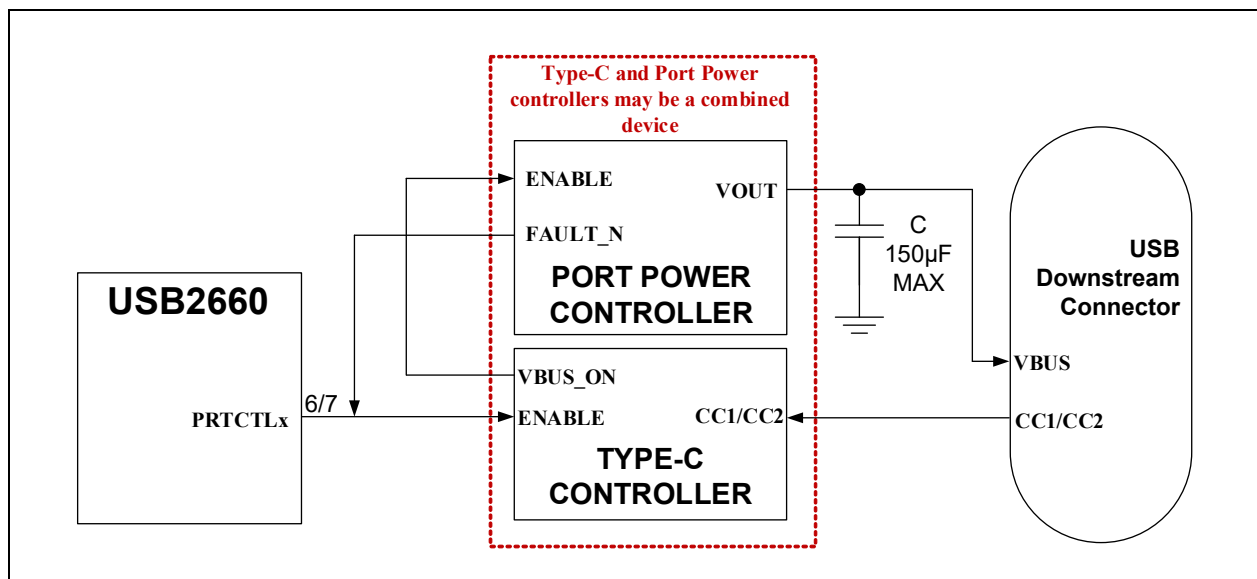

USB2660

Note: The implementation as shown in [Figure 4-4](#) assumes that the Type-C controller has an active-high enable input, and the port power controller has an active-low, open-drain style fault indicator. External polarity inversion through buffers or FETs may be required if the Type-C controller, port power controller, or both have different I/O characteristics.

4.3 USB Protection

The use of external protection circuitry may be required to provide additional ESD protection beyond what is included in the hub IC. These generally are grouped into three categories:

- TVS protection diodes
 - ESD protection for IEC-61000-4-2 system-level tests
- Application-targeted protection ICs or galvanic isolation devices
 - DC overvoltage protection for short-to-battery protection
- Common-mode chokes
 - For EMI reduction

The USB2660 can be used in conjunction with these types of devices, but it is important to understand the negative effect that these devices may have on USB signal integrity and to select components accordingly and to follow the implementation guidelines from the manufacturer of these devices. The following general guidelines may also be used for implementing these devices:

- Select only devices that are designed specifically for high-speed applications. Per the USB specification, a total of 5 pF is budgeted for connector, PCB traces, and protection circuitry.
- Place these devices as close as possible to the USB connector.
- Never branch the USB signals to reach protection devices. Always place the protection devices directly on top of the USB differential traces.
- Always ensure a very low impedance path to a large ground plane. The effectiveness of TVS devices depends heavily on effective grounding.
- Place TVS diodes on the same layer as the USB signal trace. Avoid vias or place vias behind the TVS device if possible.

Note: Microchip PHYBoost configuration options are available for compensating the negative effects of these devices. This feature may help to overcome marginal failures. It is simplest to determine the appropriate setting using lab experiments, such as USB eye diagram tests, on physical hardware.

4.4 GND and SHIELD Recommendations

The GND pins of the USB connector must be connected to the PCB with a low impedance path directly to a large GND plane.

The SHIELD pins of the USB connector may be connected in one of two ways:

- (*Recommended*) To GND through a resistor and capacitor in parallel. An RC filter can help to decouple and minimize EMI between a PCB and a USB cable.
- Directly to the GND plane.

The recommended implementation is shown in [Figure 4-5](#).

FIGURE 4-5: RECOMMENDED USB CONNECTOR GND AND SHIELD CONNECTIONS

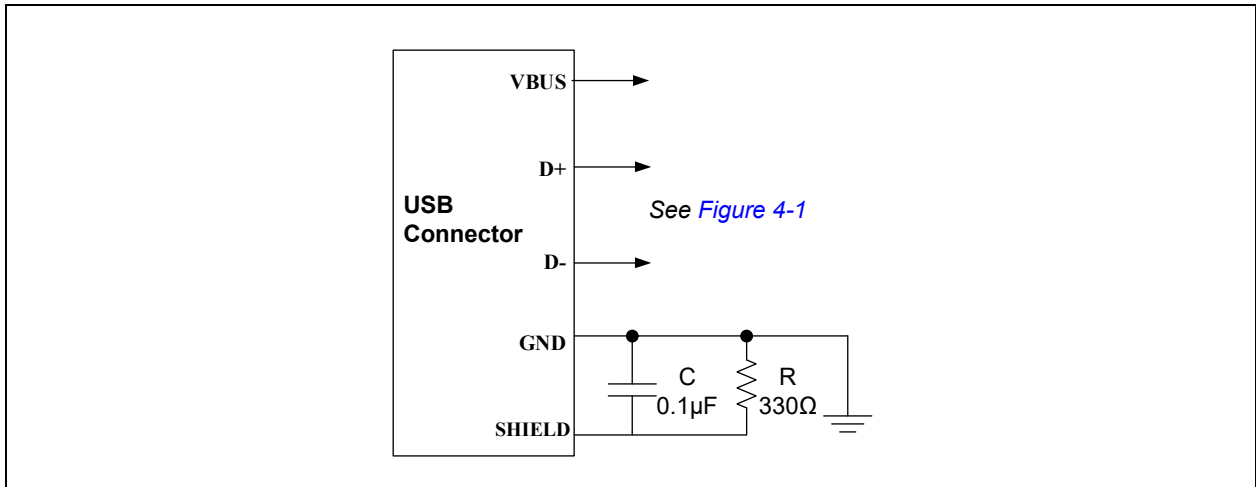

USB2660

5.0 CARD READER INTERFACE

5.1 Secure Digital™/MultiMediaCard™ Slot

The USB2660 supports Secure Digital (SD) 2.0 including HS-SD and SDHC media. Newer media and small form factor SD media (that is, microSD) is also supported due to backwards compatibility requirements on all compliant SD media, though newer features and performance cannot be taken advantage of.

One/Four/Eight-bit MultiMediaCard (MMC) 4.2 is also supported on the same interface and card slot. Newer MMC media and embedded MMC (eMMC) media is also supported due to backwards compatibility requirements on all compliant MMC media, though newer features and performance cannot be taken advantage of.

The USB2660 supports Memory Stick® 1.43, Memory Stick Pro Format 1.02, Memory Stick Pro-HG Duo Format 1.01, Memory Stick Duo 1.10 on the same interface and card slot.

The USB2660 supports xD-Picture Card™ 1.2 on the same interface and card slot.

If designing with a standard SD/MMC card slot, follow [Figure 5-1](#). If designing with an embedded eMMC memory, follow [Figure 5-2](#). If designing with a microSD card slot, follow [Figure 5-3](#).

If designing with a Memory Stick card slot refer to [Figure 5-4](#). If designing with an xD-Picture Card slot, refer to [Figure 5-5](#). If designing an implementation using a standard SD card on slot (2), refer to [Figure 5-6](#).

FIGURE 5-1: SD/MMC MEDIA SLOT 1

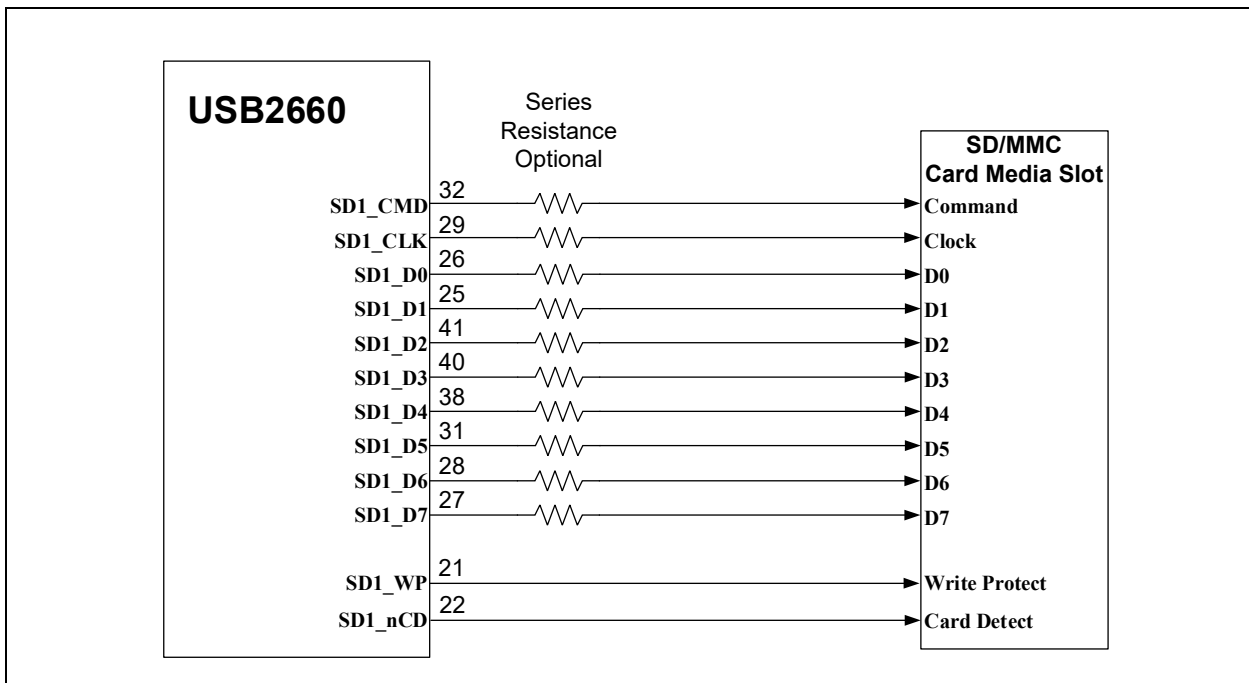
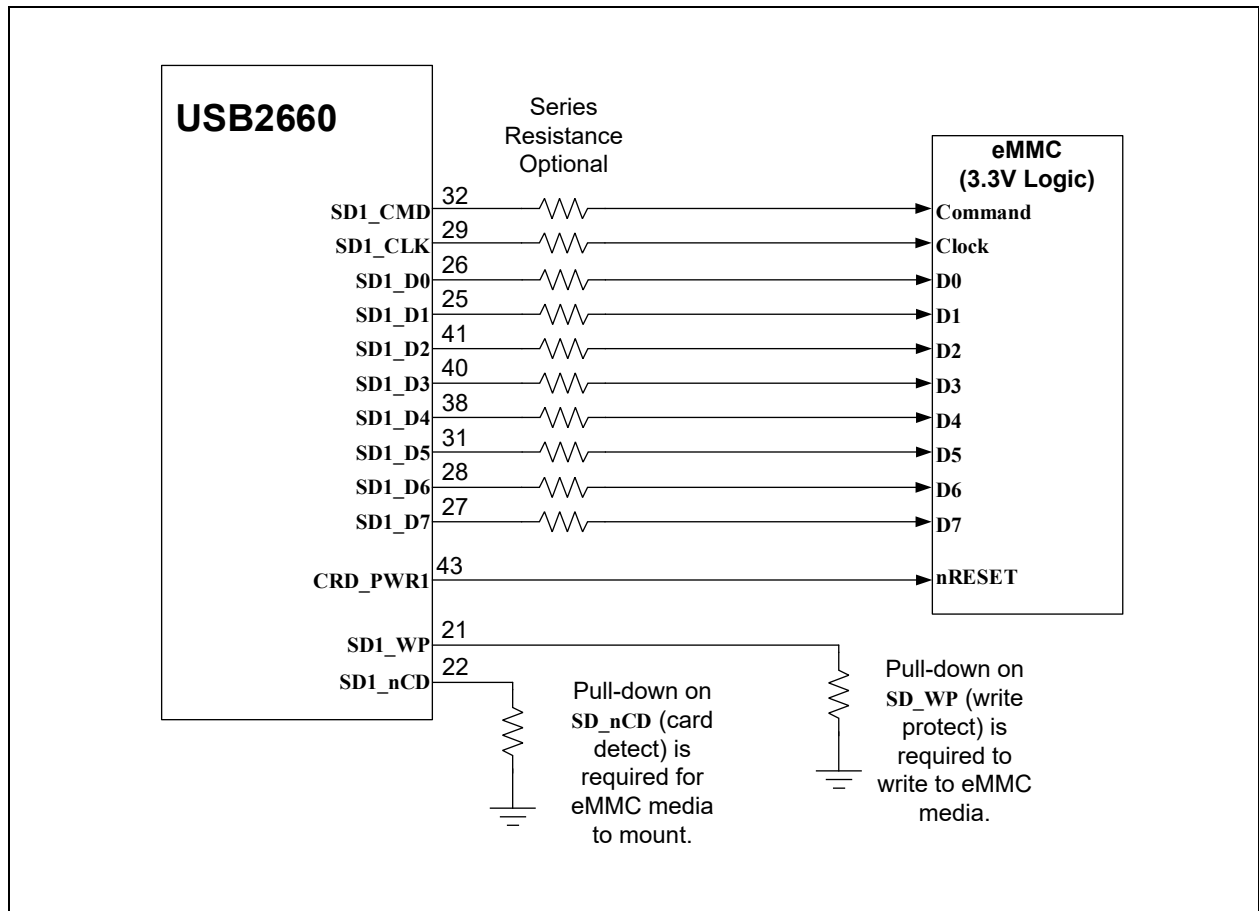

FIGURE 5-2: eMMC MEMORY CONNECTIONS



USB2660

FIGURE 5-3: MICROSD CARD SLOT CONNECTIONS

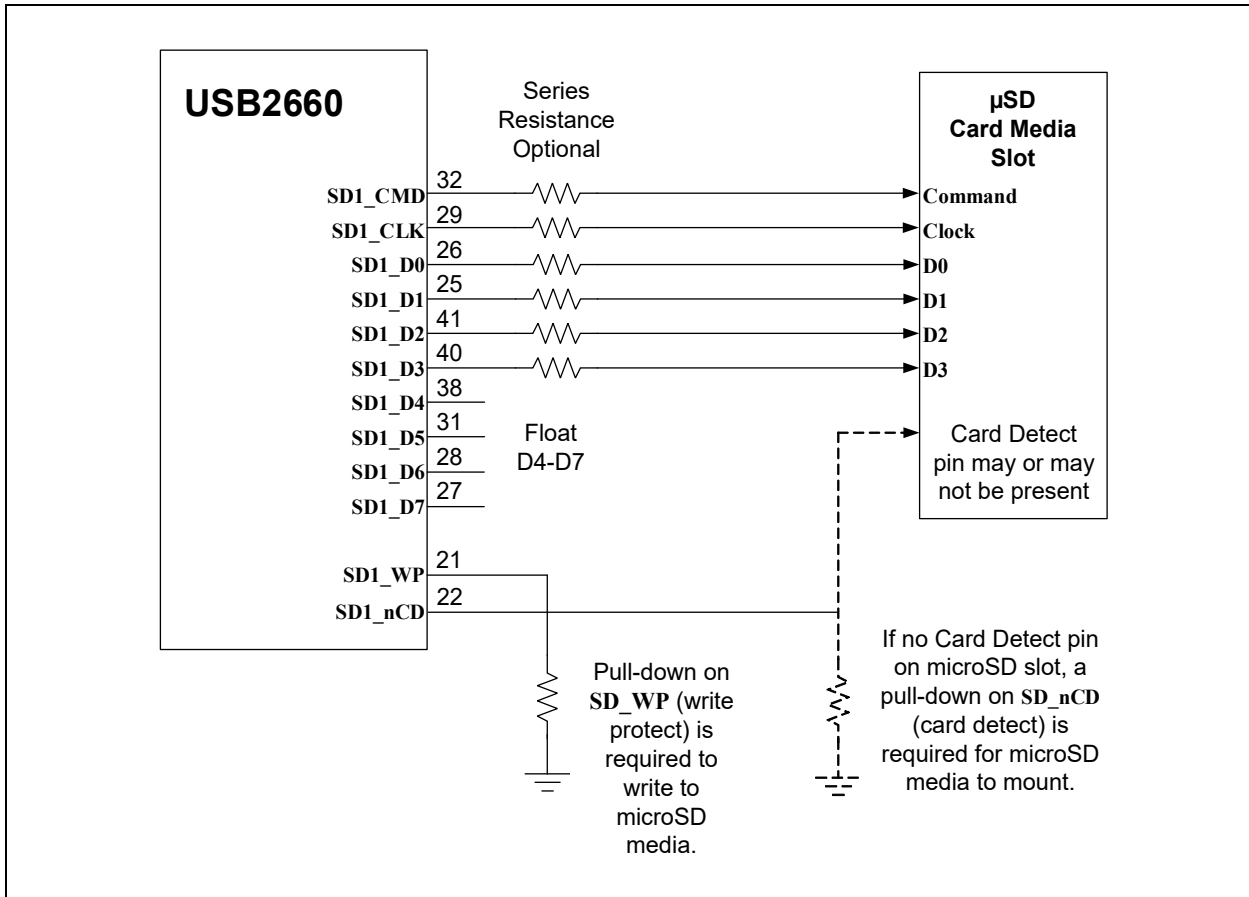

FIGURE 5-4: MEMORY STICK® CARD SLOT CONNECTIONS

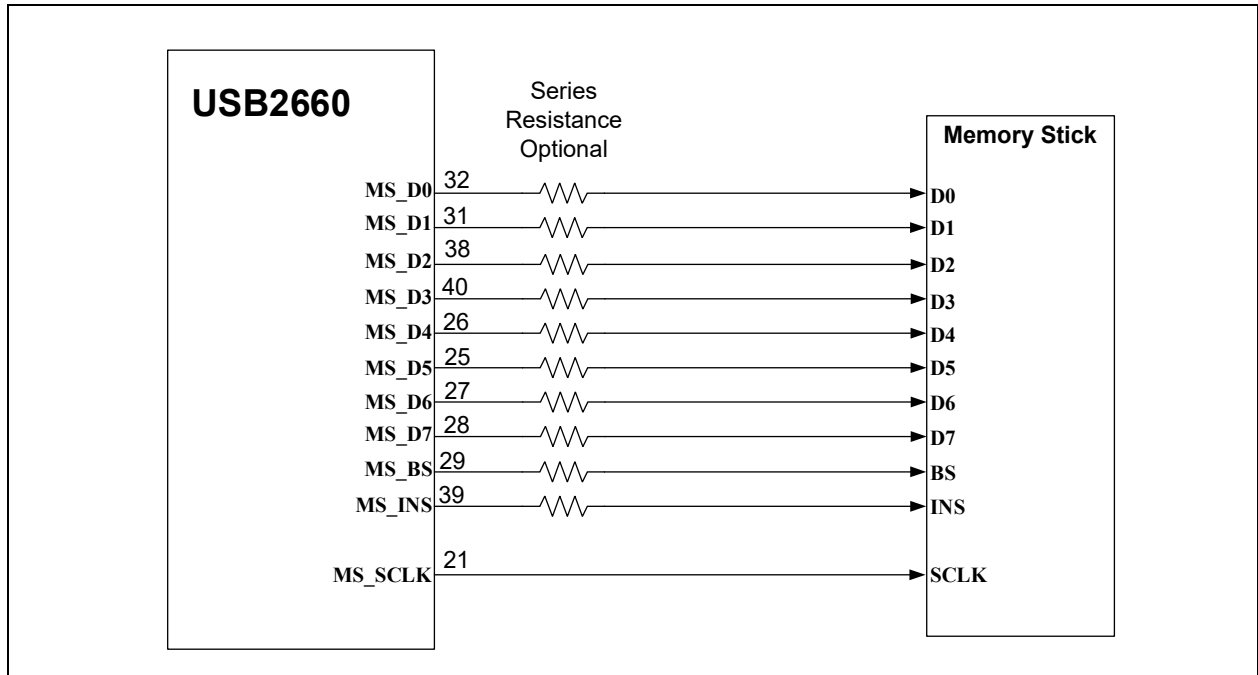
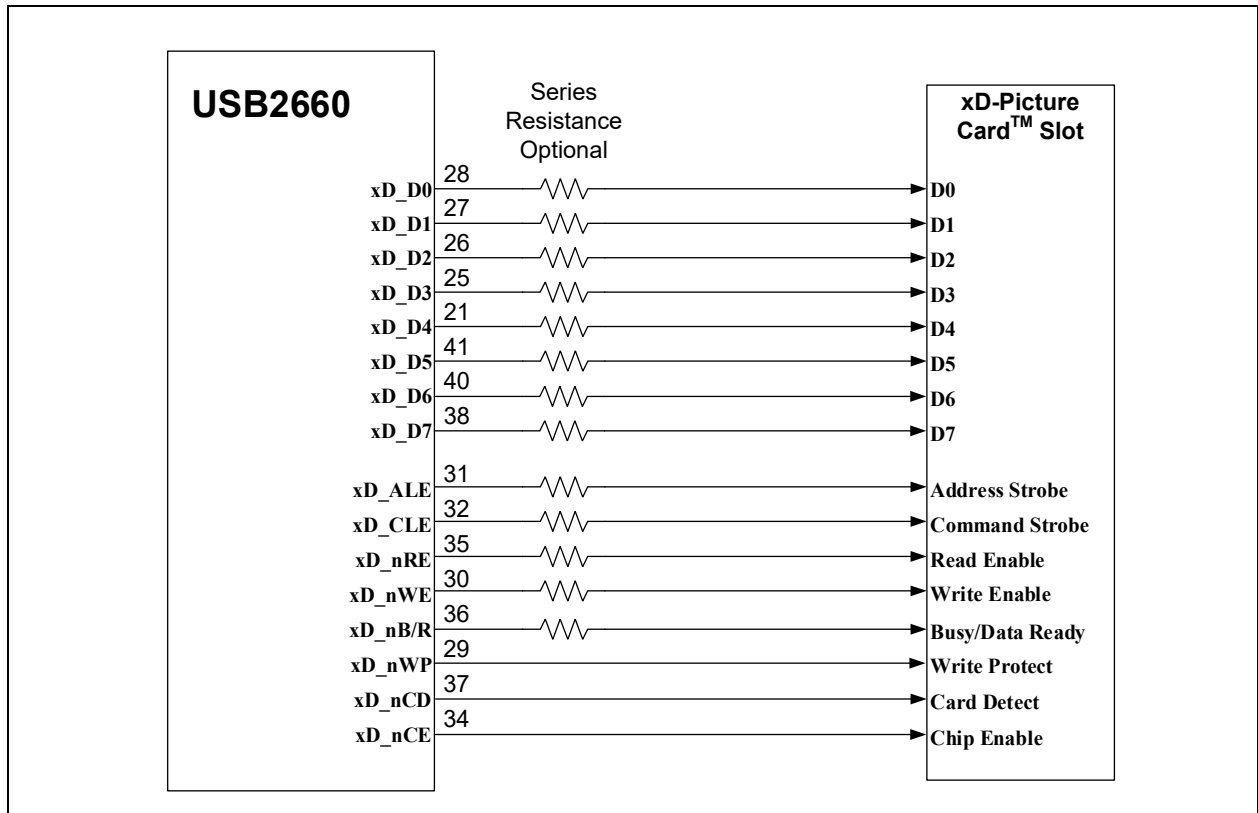
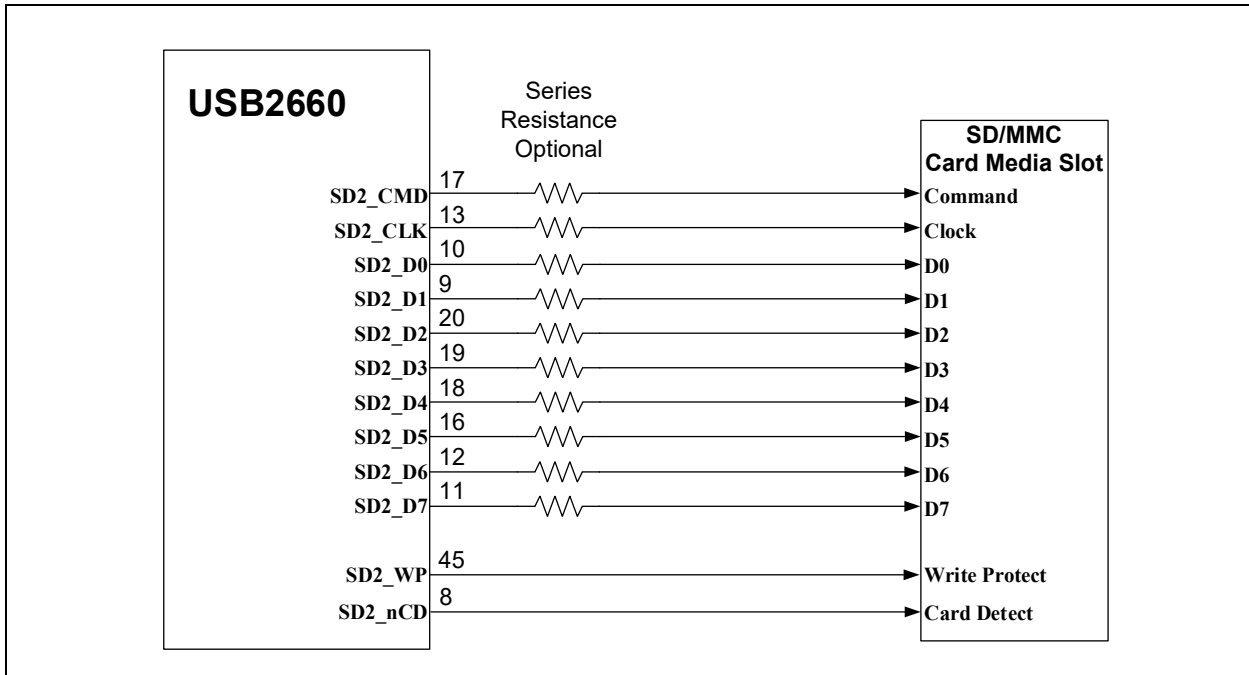

FIGURE 5-5: XD-PICTURE CARD™ SLOT CONNECTIONS



USB2660

FIGURE 5-6: SD CARD SLOT 2 CONNECTIONS



5.2 Card Power Switch

The USB2660 includes an internal 3.3V power switch on CRD_PWR capable of supplying up to 200 mA continuously to the attached media. The card power switch includes fault protection and will automatically shut off the output if current draw exceeds the 200 mA maximum.

Note: The default setting for card power current limit is 200 mA. It may be optionally set to 100 mA via EEPROM configuration if desired.

The card power output should include some bulk capacitance to maintain voltage stability during card use. A 4.7 μF ceramic capacitor is sufficient for most use-cases. Certain high-power media may require more. Smaller capacitances can also be added to filter out high-frequency noise, if present in the system.

An LED may be optionally connected directly to the card power output to give visual indication of card power.

FIGURE 5-7: CRD_PWR CARD MEDIA POWER SUPPLY SWITCH

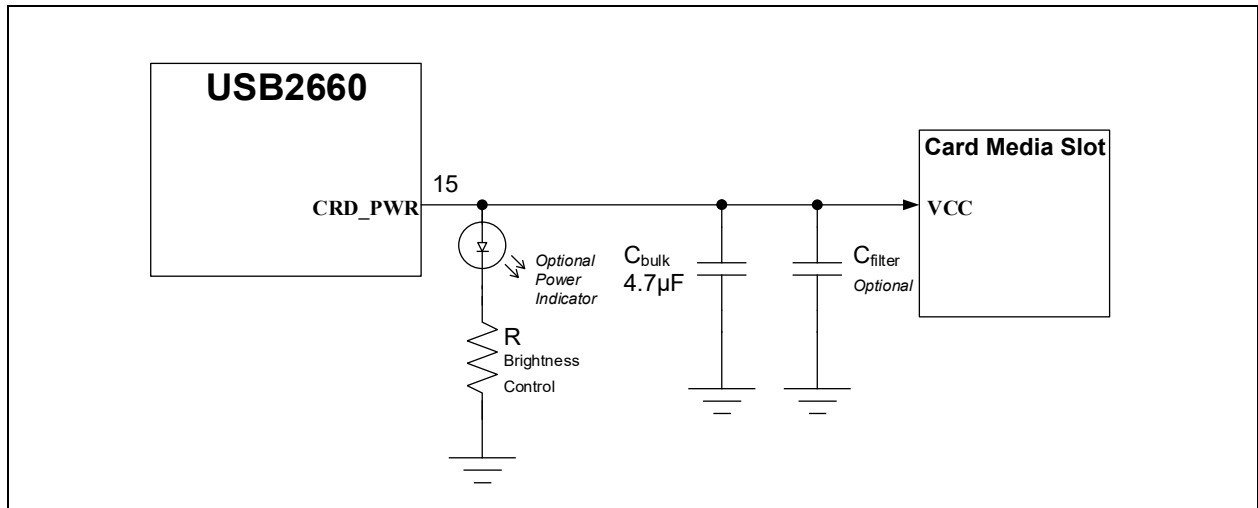

If the internal card power switch is not used, it is still recommended to use the **CRD_PWR** pin to control the supply to the card media slot. This allows the internal logic of the USB2660 to reset power to the card during error recovery attempts.

FIGURE 5-8: EXTERNAL CARD POWER SUPPLY SWITCH RECOMMENDED CONNECTIONS

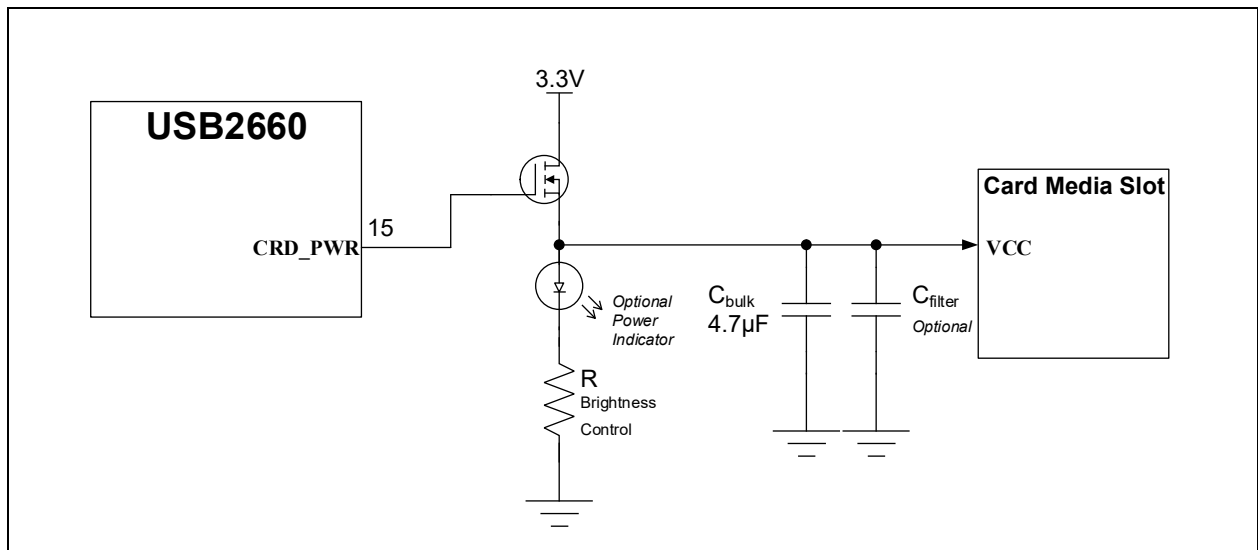

USB2660

6.0 CLOCK CIRCUIT

6.1 Crystal and External Clock Connection

A 24.000 MHz (± 350 ppm) reference clock is the source for the USB interface and for all other functions of the device. For exact specifications and tolerances, refer to the latest revision of the *USB2660 Data Sheet*.

- **XTAL1(CLKIN)** (pin 61) is the clock circuit input for the USB2660. This pin requires a capacitor to ground. One side of the crystal connects to this pin.
- **XTAL2** (pin 60) is the clock circuit output for the USB2660. This pin requires a capacitor to ground. One side of the crystal connects to this pin.
- A 1 megohm resistor (1 M Ω) is required connected across the **XTAL1** and **XTAL2** pins.
- The crystal loading capacitor values are system-dependent, based on the total C_L specification of the crystal and the stray capacitance value. The PCB design, crystal, and layout all contribute to the characteristics of this circuit. A commonly used formula for calculating the appropriate physical C_1 and C_2 capacitor values is:

$$C_L = ((C_{X1})(C_{X2}) / (C_{X1} + C_{X2}))$$

Where: C_L is the specification from the crystal data sheet, $C_{X1} = C_{\text{stray}} + C_1$, $C_{X2} = C_{\text{stray}} + C_2$

Note: C_{stray} is the stray/parasitic capacitance due to PCB layout. It can be assumed to be very small, in the 1-2 pF range, and then verified by physical experiments in the lab if PCB simulation tools are not available.

- Alternately, a 24.000 MHz, 1.2V-3.3V clock oscillator may be supplied to **XTAL1(CLKIN)** to provide the clock source for the USB2660. When using a single-ended clock source, **XTAL2** should be left floating as a No Connect (NC).

FIGURE 6-1: CRYSTAL AND OSCILLATOR CONNECTIONS

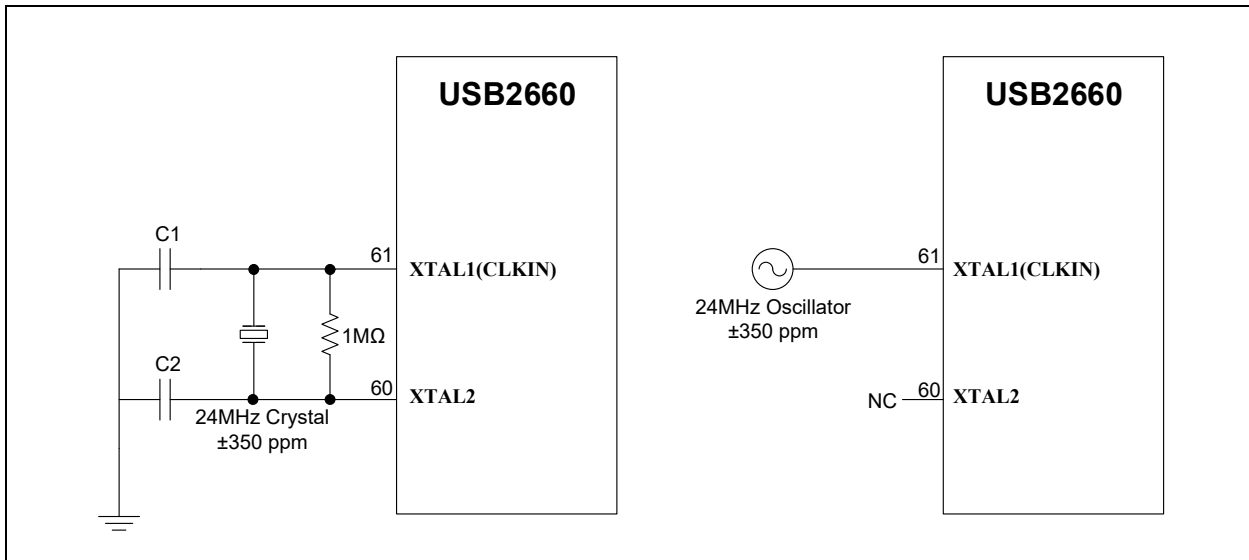

7.0 POWER AND STARTUP

7.1 RBIAS Resistor

RBIAS (pin 63) on the USB2660 must connect to ground through a 12 kΩ resistor with a tolerance of 1.0%. This is used to set up critical bias currents for the internal circuitry. This should be placed as close as possible to the IC pin, and be given a dedicated, low-impedance path to a ground plane.

7.2 Board Power Supplies

7.2.1 POWER RISE TIME

The power rail voltage and rise time should adhere to the supply rise time specification as defined in the *USB2660 Data Sheet*.

If a monotonic/fast power rail rise cannot be assured, then the **RESET_N** signal should be controlled by a reset supervisor and only released when the power rail has reached a stable level.

7.2.2 CURRENT CAPABILITY

It is important to size the 3.3V power rails appropriately. The 3.3V power supply must be capable of supplying sufficient power for the USB2660 (up to 330 mA at 3.3V) as well as the card media supported (up to 200 mA if using the internal card power supply output on **CRD_PWR**).

7.3 Reset Circuit

RESET_N (pin 54) is an active-low reset input. This signal resets all logic and registers within the USB2660. A hardware reset (**RESET_N** assertion) is not required following power-up. Please refer to the latest copy of the *USB2660 Data Sheet* for reset timing requirements. [Figure 7-1](#) shows a recommended reset circuit for powering up the USB2660 when reset is triggered by the power supply. The values for the “R” resistor and “C” capacitor are not critical and may be adjusted per individual system needs or preferences.

FIGURE 7-1: RESET TRIGGERED BY POWER SUPPLY

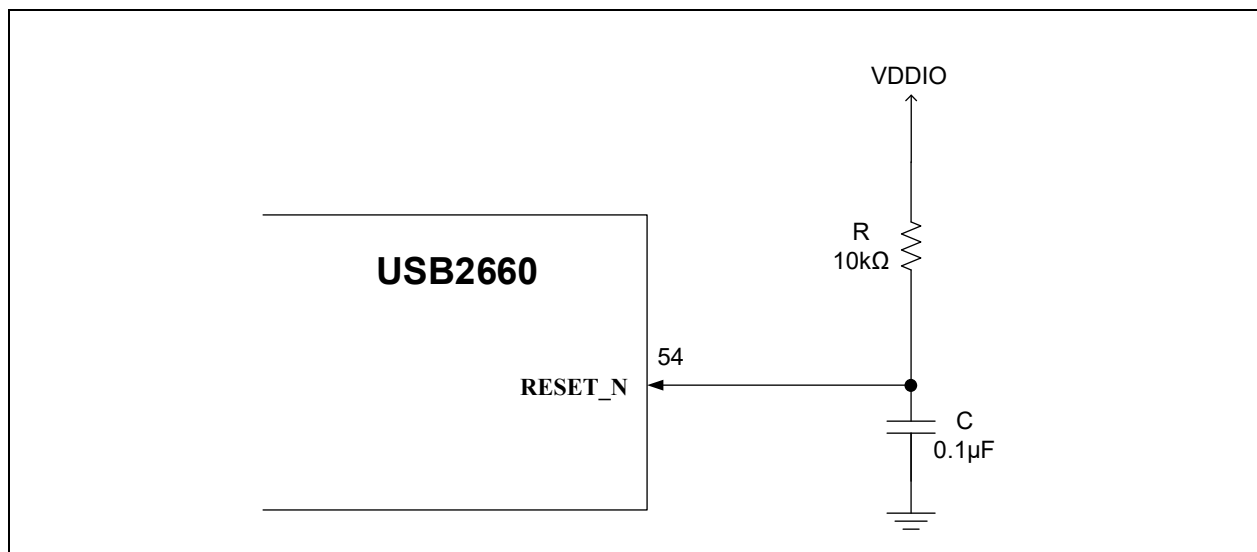

[Figure 7-2](#) details the recommended reset circuit for applications where reset is driven by an external CPU/MCU. The reset out pin (**RST_OUT_N**) from the CPU/MCU provides the warm reset after power-up. The values for the “R” resistor and “C” capacitor are not critical and may be adjusted per individual system needs or preferences.

USB2660

FIGURE 7-2: RESET CIRCUIT INTERFACE WITH CPU/MCU RESET OUTPUT

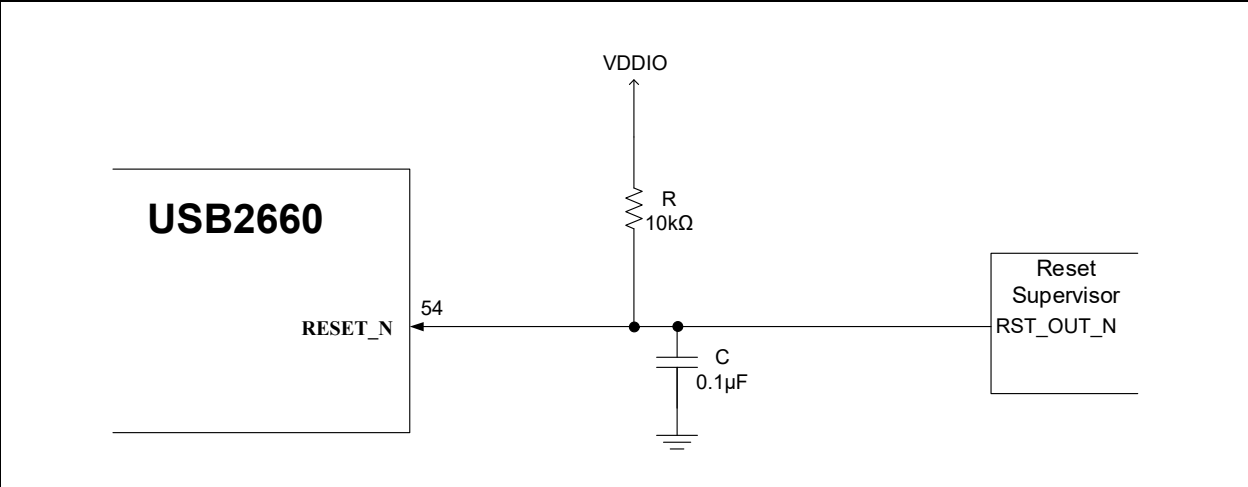

8.0 CONFIGURATION OPTIONS

The USB2660 can be configured to allow for customizable vendor, product, and device IDs, serial number, product string descriptors, and more from one of the following methods:

- I²C 512 Byte (512x8) EEPROM memory device
- SPI interface executing a new firmware image in place

8.1 External EEPROM

An external EEPROM is not required for USB2660 operation — internal defaults may be used for many applications. If the external EEPROM is not detected at boot, internal defaults will be loaded. See [Figure 8-1](#).

FIGURE 8-1: EEPROM CONNECTIONS

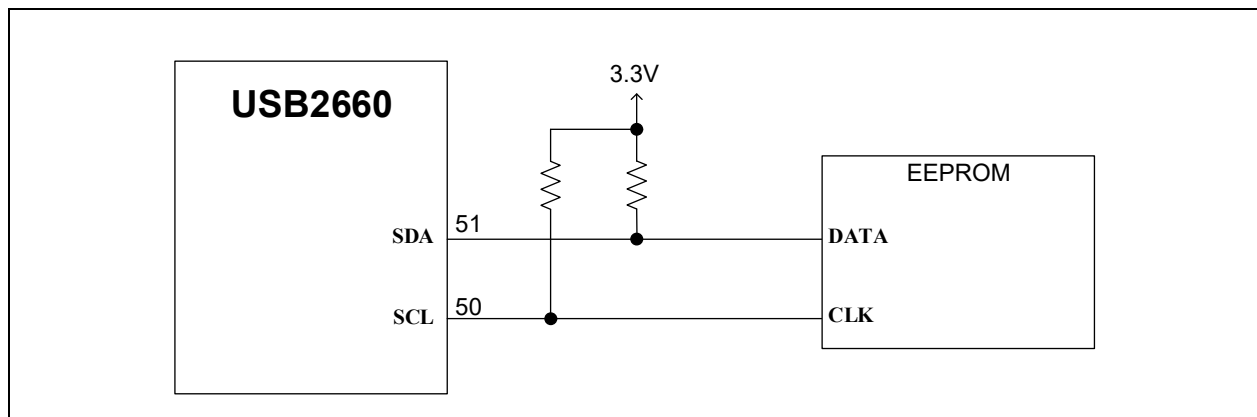

8.2 External SPI Flash Memory

For custom applications, an external SPI Flash device may be used to execute a unique firmware image. In most applications, this functionality is not used.

By default, the USB2660 executes firmware from an internal read only memory (ROM). The USB2660 supports optional firmware execution from an external SPI Flash device. An SPI Flash device is only required if a custom firmware is required for the application.

The following are the key operational parameters:

- The SPI interface can operate at 60 MHz or 30 MHz. The speed is selected by the SPI_SPD_SEL hardware configuration strap.
- The SPI interface can operate in 1-bit or 2-bit mode.
- Mode 0 or Mode 3 SPI Flash memory devices are supported.
- Generally, a 256 kB or larger memory size is required, but the final size is determined by the size of the custom firmware image after all customizations are implemented.

If an external SPI Flash device is used, the recommended schematic connections are shown in [Figure 8-2](#).

USB2660

FIGURE 8-2: DUAL SPI FLASH CONNECTIONS

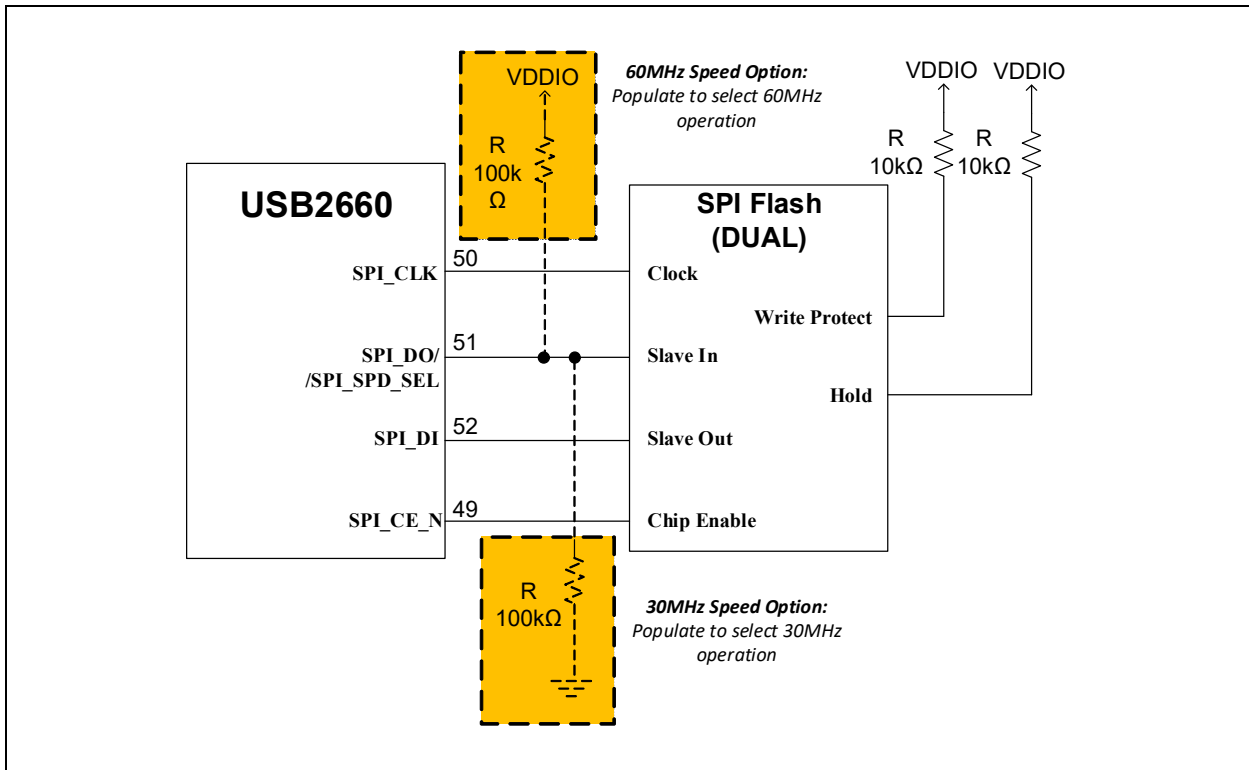

8.3 Non-Removable Port Settings

In a typical USB2660 application, downstream ports are routed to a user-accessible USB connector, and hence the downstream port should be configured as a removable port. By default, all downstream ports are configured as removable ports. If modifying the default settings to reconfigure a port as non-removable, configuration must be handled through either external EEPROM or SPI Flash device.

The following guidelines can be used to determine which setting to use:

- If the port is routed to a user-accessible USB connector, it is *removable*.
- If the port is routed to a permanently-attached and embedded USB device on the same PCB, or non-user-accessible wiring or cable harness, it is *non-removable*.

Note: The removable/non-removable device settings do not impact the operation of the hub in any way. The settings only modify select USB descriptors, which the USB host may use to understand if a port is a user-accessible port, or if the device is a permanently-attached device. Under standard operating conditions, the USB host may or may not modify its operation based upon this information. Certain USB compliance tests are impacted by this setting, so designs that must undergo USB compliance testing and certification must ensure the configuration settings are correct.

8.4 Self-Powered/Bus-Powered Settings

In a typical USB2660 application, the hub should be configured as self-powered, which is the default configuration setting. If modifying the default setting to bus-powered operation, configuration must be handled through either external EEPROM or SPI Flash device.

The following guidelines can be used to determine which setting to use:

- If the entire system (hub included) is powered completely from the Upstream USB connector's **VBUS** pin, and the system is designed to operate using standard USB cabling and any standard USB host, then the hub system is *bus-powered*.
- If the entire system (hub included) is always powered by a separate power connector, then the hub system is *self-powered*.
- If the hub included is part of a larger embedded system with fixed cabling and a fixed USB host, then the hub system is most likely *self-powered* (even if all of the power is derived from the upstream USB connector's **VBUS** pin).

Note: The self-powered/bus-powered device settings do not impact the operation of the hub in any way. The settings only modify select USB descriptors, which the USB host will use to budget power accordingly. Since a standard USB2.0 port is required to supply 500 mA to the downstream port, a self-powered hub and all of its downstream ports must continue to operate within that 500 mA budget. A USB host will typically limit the downstream ports of a self-powered hub to 100 mA. Any device that connects to a self-powered hub which declares it needs more than 100 mA will be prevented from operating by the USB host.

USB2660

NOTES:

9.0 HARDWARE CHECKLIST SUMMARY

TABLE 9-1: HARDWARE DESIGN CHECKLIST

Section	Check	Explanation	√	Notes
Section 2.0, "General Considerations"	Section 2.1, "Required References"	All documents are on hand.		
	Section 2.2, "Pin Check"	Verify that the pins match the data sheet.		
	Section 2.3, "Ground"	Verify that the grounds are tied together.		
	Section 2.4, "USB-IF-Compliant USB Connector"	If present, verify that a USB-IF-compliant USB connector with an assigned TID is used in the design (if USB compliance is required for the design).		
Section 3.0, "Power"		<ul style="list-style-type: none"> Ensure that VDD33 is in the range 3.0V to 3.6V, 0.1 μF capacitors are connected to pins 5, 14, 24, 33, 42, 47, 57 and 64. Ensure that VDD33 (pins 24 and 64) each has a 4.7 μF capacitor to GND. 		
Section 4.0, "USB Signals"	Section 4.1, "USB Interface"	Verify that the upstream port USB data pins are correctly routed to the USB connectors. Pay special attention to the polarity of the USB2.0 D+ and D- data lines. Also verify that VBUS_DET is properly connected and the voltage is divided from nominal 5V VBUS to the 3.3V logic level the hub requires.		
	Section 4.2, "Downstream USB Ports"	Verify that the downstream port USB data pins are correctly routed to the USB connectors. Pay special attention to the polarity of the USB2.0 D+ and D- data lines. If the downstream ports are standard Type-A ports, verify that PRT_CTLx is properly connected to both the 'enable' pin of the downstream port power controller and the fault indicator output of the port power controller. If the downstream ports are standard Type-C ports, verify that PRT_CTLx is properly connected to both the 'enable' pin of the Type-C port controller and the fault indicator output of the port power controller.		
	Section 4.3, "USB Protection"	Verify that ESD/EMI protection devices are designed specifically for high-speed data applications and that the combined parasitic capacitance the protection devices, USB traces, and USB connector do not exceed 5 pF on each USB trace.		
	Section 4.4, "GND and SHIELD Recommendations"	Verify that the USB connector is properly connected to PCB ground on both the GND pins and the SHIELD pins. It is recommended that an RC filter be placed in between the SHIELD pins and PCB ground.		

TABLE 9-1: HARDWARE DESIGN CHECKLIST (CONTINUED)

Section	Check	Explanation	√	Notes
Section 5.0, "Card Reader Interface"	Section 5.1, "Secure Digital/MultiMediaCard™ Slot"	Verify that connections to a standard SD/MMC card slot, embedded MMC memory, microSD card slot, Memory Stick, xD Picture Card slot, or SD card slot 2 are correct and follow the diagrams in Figure 5-1 , Figure 5-2 , Figure 5-3 , Figure 5-4 , Figure 5-5 , or Figure 5-6 .		
	Section 5.2, "Card Power Switch"	Verify that CRD_PWR either connects directly to the card media or card media slot supply power, or CRD_PWR enables an external supply switch if the internal card power switch is not used directly.		
Section 6.0, "Clock Circuit"	Section 6.1, "Crystal and External Clock Connection"	Confirm the crystal or clock is 24.000 MHz (± 350 ppm). If a single-ended clock is used, ensure it is connected to XTAL1 while leaving XTAL2 floating. If a crystal is used, ensure the loading capacitors are appropriately sized for the crystal loading requirement.		
Section 7.0, "Power and Startup"	Section 7.1, "RBIAS Resistor"	Confirm that a 12.0 k Ω 1% resistor is connected between the RBIAS pin and PCB ground.		
	Section 7.2, "Board Power Supplies"	Verify that the board power supplies deliver 3.0V-3.6V to the hub power rails, and that the power-on rise time meets the requirement of the hub as defined in the data sheet. If the rise time requirement cannot be met, ensure that the RESET_N line is held low until the power regulators reach a steady state.		
Section 8.0, "Configuration Options"	Section 7.3, "Reset Circuit"	Ensure that the RESET_N signal has an external pull-up resistor, or is otherwise properly controlled by an external SOC, MCU, or Reset supervisor device.		
	Section 8.1, "External EEPROM"	If an EEPROM memory device is used, verify that the EEPROM is connected according to the diagram in Figure 8-1 .		
	Section 8.2, "External SPI Flash Memory"	Determine if a custom SPI FW image is required, and which mode of operation the selected SPI Flash device must support. If an SPI Flash memory device is used, verify that the SPI Flash device is connected according to the diagram in Figure 8-2 .		
	Section 8.3, "Non-Removable Port Settings"	Verify the application requirements for removable and non-removable USB downstream ports. If any port must be configured as non-removable, then the hub must be configured via EEPROM or SPI Flash device.		
	Section 8.4, "Self-Powered/Bus-Powered Settings"	Verify the application requirements for Self-Powered or Bus-Powered operation. If self-powered operation is required, then no additional configuration or circuitry is required. If bus-powered operation is required, then the hub must be configured via EEPROM or SPI Flash device.		

APPENDIX A: REVISION HISTORY

TABLE A-1: REVISION HISTORY

Revision Level & Date	Section/Figure/Entry	Correction
DS00004692A (08-03-22)	Initial release	

USB2660

THE MICROCHIP WEB SITE

Microchip provides online support via our WWW site at www.microchip.com. This web site is used as a means to make files and information easily available to customers. Accessible by using your favorite Internet browser, the web site contains the following information:

- **Product Support** – Data sheets and errata, application notes and sample programs, design resources, user's guides and hardware support documents, latest software releases and archived software
- **General Technical Support** – Frequently Asked Questions (FAQ), technical support requests, online discussion groups, Microchip consultant program member listing
- **Business of Microchip** – Product selector and ordering guides, latest Microchip press releases, listing of seminars and events, listings of Microchip sales offices, distributors and factory representatives

CUSTOMER CHANGE NOTIFICATION SERVICE

Microchip's customer notification service helps keep customers current on Microchip products. Subscribers will receive e-mail notification whenever there are changes, updates, revisions or errata related to a specified product family or development tool of interest.

To register, access the Microchip web site at www.microchip.com. Under "Support", click on "Customer Change Notification" and follow the registration instructions.

CUSTOMER SUPPORT

Users of Microchip products can receive assistance through several channels:

- Distributor or Representative
- Local Sales Office
- Field Application Engineer (FAE)
- Technical Support

Customers should contact their distributor, representative or Field Application Engineer (FAE) for support. Local sales offices are also available to help customers. A listing of sales offices and locations is included in the back of this document.

Technical support is available through the web site at: <http://microchip.com/support>

Note the following details of the code protection feature on Microchip products:

- Microchip products meet the specifications contained in their particular Microchip Data Sheet.
- Microchip believes that its family of products is secure when used in the intended manner, within operating specifications, and under normal conditions.
- Microchip values and aggressively protects its intellectual property rights. Attempts to breach the code protection features of Microchip product is strictly prohibited and may violate the Digital Millennium Copyright Act.
- Neither Microchip nor any other semiconductor manufacturer can guarantee the security of its code. Code protection does not mean that we are guaranteeing the product is "unbreakable" Code protection is constantly evolving. Microchip is committed to continuously improving the code protection features of our products.

This publication and the information herein may be used only with Microchip products, including to design, test, and integrate Microchip products with your application. Use of this information in any other manner violates these terms. Information regarding device applications is provided only for your convenience and may be superseded by updates. It is your responsibility to ensure that your application meets with your specifications. Contact your local Microchip sales office for additional support or, obtain additional support at <https://www.microchip.com/en-us/support/design-help/client-support-services>.

THIS INFORMATION IS PROVIDED BY MICROCHIP "AS IS". MICROCHIP MAKES NO REPRESENTATIONS OR WARRANTIES OF ANY KIND WHETHER EXPRESS OR IMPLIED, WRITTEN OR ORAL, STATUTORY OR OTHERWISE, RELATED TO THE INFORMATION INCLUDING BUT NOT LIMITED TO ANY IMPLIED WARRANTIES OF NON-INFRINGEMENT, MERCHANTABILITY, AND FITNESS FOR A PARTICULAR PURPOSE, OR WARRANTIES RELATED TO ITS CONDITION, QUALITY, OR PERFORMANCE.

IN NO EVENT WILL MICROCHIP BE LIABLE FOR ANY INDIRECT, SPECIAL, PUNITIVE, INCIDENTAL, OR CONSEQUENTIAL LOSS, DAMAGE, COST, OR EXPENSE OF ANY KIND WHATSOEVER RELATED TO THE INFORMATION OR ITS USE, HOWEVER CAUSED, EVEN IF MICROCHIP HAS BEEN ADVISED OF THE POSSIBILITY OR THE DAMAGES ARE FORESEEABLE. TO THE FULLEST EXTENT ALLOWED BY LAW, MICROCHIP'S TOTAL LIABILITY ON ALL CLAIMS IN ANY WAY RELATED TO THE INFORMATION OR ITS USE WILL NOT EXCEED THE AMOUNT OF FEES, IF ANY, THAT YOU HAVE PAID DIRECTLY TO MICROCHIP FOR THE INFORMATION.

Use of Microchip devices in life support and/or safety applications is entirely at the buyer's risk, and the buyer agrees to defend, indemnify and hold harmless Microchip from any and all damages, claims, suits, or expenses resulting from such use. No licenses are conveyed, implicitly or otherwise, under any Microchip intellectual property rights unless otherwise stated.

Trademarks

The Microchip name and logo, the Microchip logo, Adaptec, AVR, AVR logo, AVR Freaks, BesTime, BitCloud, CryptoMemory, CryptoRF, dsPIC, flexPWR, HELDO, IGLOO, JukeBlox, KeeLoq, Klear, LANCheck, LinkMD, maXStylus, maXTouch, MediaLB, megaAVR, Microsemi, Microsemi logo, MOST, MOST logo, MPLAB, OptoLyzer, PIC, picoPower, PICSTART, PIC32 logo, PolarFire, Prochip Designer, QTouch, SAM-BA, SenGenuity, SpyNIC, SST, SST Logo, SuperFlash, Symmetricom, SyncServer, Tachyon, TimeSource, tinyAVR, UNI/O, Vectron, and XMEGA are registered trademarks of Microchip Technology Incorporated in the U.S.A. and other countries.

AgileSwitch, APT, ClockWorks, The Embedded Control Solutions Company, EtherSynch, Flashtec, Hyper Speed Control, HyperLight Load, Libero, motorBench, mTouch, Powermite 3, Precision Edge, ProASIC, ProASIC Plus, ProASIC Plus logo, Quiet-Wire, SmartFusion, SyncWorld, Temux, TimeCesium, TimeHub, TimePictra, TimeProvider, TrueTime, and ZL are registered trademarks of Microchip Technology Incorporated in the U.S.A.

Adjacent Key Suppression, AKS, Analog-for-the-Digital Age, Any Capacitor, AnyIn, AnyOut, Augmented Switching, BlueSky, BodyCom, Clockstudio, CodeGuard, CryptoAuthentication, CryptoAutomotive, CryptoCompanion, CryptoController, dsPICDEM, dsPICDEM.net, Dynamic Average Matching, DAM, ECAN, Espresso T1S, EtherGREEN, GridTime, IdealBridge, In-Circuit Serial Programming, ICSP, INICnet, Intelligent Paralleling, IntelliMOS, Inter-Chip Connectivity, JitterBlocker, Knob-on-Display, KoD, maxCrypto, maxView, memBrain, Mindi, MiWi, MPASM, MPF, MPLAB Certified logo, MPLIB, MPLINK, MultiTRAK, NetDetach, Omniscient Code Generation, PICDEM, PICDEM.net, PICkit, PICtail, PowerSmart, PureSilicon, QMatrix, REAL ICE, Ripple Blocker, RTAX, RTG4, SAM-ICE, Serial Quad I/O, simpleMAP, SimpliPHY, SmartBuffer, SmartHLS, SMART-I.S., storClad, SQI, SuperSwitcher, SuperSwitcher II, Switchtec, SynchroPHY, Total Endurance, Trusted Time, TSHARC, USBCheck, VariSense, VectorBlox, VeriPHY, ViewSpan, WiperLock, XpressConnect, and ZENA are trademarks of Microchip Technology Incorporated in the U.S.A. and other countries.

SQTP is a service mark of Microchip Technology Incorporated in the U.S.A.

The Adaptec logo, Frequency on Demand, Silicon Storage Technology, and Symmcom are registered trademarks of Microchip Technology Inc. in other countries.

GestIC is a registered trademark of Microchip Technology Germany II GmbH & Co. KG, a subsidiary of Microchip Technology Inc., in other countries.

All other trademarks mentioned herein are property of their respective companies.

© 2022, Microchip Technology Incorporated and its subsidiaries.

All Rights Reserved.

ISBN: 978-1-6683-1013-7

For information regarding Microchip's Quality Management Systems, please visit www.microchip.com/quality.



MICROCHIP

Worldwide Sales and Service

AMERICAS

Corporate Office

2355 West Chandler Blvd.
Chandler, AZ 85224-6199

Tel: 480-792-7200

Fax: 480-792-7277

Technical Support:

[http://www.microchip.com/
support](http://www.microchip.com/support)

Web Address:

www.microchip.com

Atlanta

Duluth, GA

Tel: 678-957-9614

Fax: 678-957-1455

Austin, TX

Tel: 512-257-3370

Boston

Westborough, MA

Tel: 774-760-0087

Fax: 774-760-0088

Chicago

Itasca, IL

Tel: 630-285-0071

Fax: 630-285-0075

Dallas

Addison, TX

Tel: 972-818-7423

Fax: 972-818-2924

Detroit

Novi, MI

Tel: 248-848-4000

Houston, TX

Tel: 281-894-5983

Indianapolis

Noblesville, IN

Tel: 317-773-8323

Fax: 317-773-5453

Tel: 317-536-2380

Los Angeles

Mission Viejo, CA

Tel: 949-462-9523

Fax: 949-462-9608

Tel: 951-273-7800

Raleigh, NC

Tel: 919-844-7510

New York, NY

Tel: 631-435-6000

San Jose, CA

Tel: 408-735-9110

Tel: 408-436-4270

Canada - Toronto

Tel: 905-695-1980

Fax: 905-695-2078

ASIA/PACIFIC

Australia - Sydney

Tel: 61-2-9868-6733

China - Beijing

Tel: 86-10-8569-7000

China - Chengdu

Tel: 86-28-8665-5511

China - Chongqing

Tel: 86-23-8980-9588

China - Dongguan

Tel: 86-769-8702-9880

China - Guangzhou

Tel: 86-20-8755-8029

China - Hangzhou

Tel: 86-571-8792-8115

China - Hong Kong SAR

Tel: 852-2943-5100

China - Nanjing

Tel: 86-25-8473-2460

China - Qingdao

Tel: 86-532-8502-7355

China - Shanghai

Tel: 86-21-3326-8000

China - Shenyang

Tel: 86-24-2334-2829

China - Shenzhen

Tel: 86-755-8864-2200

China - Suzhou

Tel: 86-186-6233-1526

China - Wuhan

Tel: 86-27-5980-5300

China - Xian

Tel: 86-29-8833-7252

China - Xiamen

Tel: 86-592-2388138

China - Zhuhai

Tel: 86-756-3210040

ASIA/PACIFIC

India - Bangalore

Tel: 91-80-3090-4444

India - New Delhi

Tel: 91-11-4160-8631

India - Pune

Tel: 91-20-4121-0141

Japan - Osaka

Tel: 81-6-6152-7160

Japan - Tokyo

Tel: 81-3-6880-3770

Korea - Daegu

Tel: 82-53-744-4301

Korea - Seoul

Tel: 82-2-554-7200

Malaysia - Kuala Lumpur

Tel: 60-3-7651-7906

Malaysia - Penang

Tel: 60-4-227-8870

Philippines - Manila

Tel: 63-2-634-9065

Singapore

Tel: 65-6334-8870

Taiwan - Hsin Chu

Tel: 886-3-577-8366

Taiwan - Kaohsiung

Tel: 886-7-213-7830

Taiwan - Taipei

Tel: 886-2-2508-8600

Thailand - Bangkok

Tel: 66-2-694-1351

Vietnam - Ho Chi Minh

Tel: 84-28-5448-2100

EUROPE

Austria - Wels

Tel: 43-7242-2244-39

Fax: 43-7242-2244-393

Denmark - Copenhagen

Tel: 45-4485-5910

Fax: 45-4485-2829

Finland - Espoo

Tel: 358-9-4520-820

France - Paris

Tel: 33-1-69-53-63-20

Fax: 33-1-69-30-90-79

Germany - Garching

Tel: 49-8931-9700

Germany - Haan

Tel: 49-2129-3766400

Germany - Heilbronn

Tel: 49-7131-72400

Germany - Karlsruhe

Tel: 49-721-625370

Germany - Munich

Tel: 49-89-627-144-0

Fax: 49-89-627-144-44

Germany - Rosenheim

Tel: 49-8031-354-560

Israel - Ra'anana

Tel: 972-9-744-7705

Italy - Milan

Tel: 39-0331-742611

Fax: 39-0331-466781

Italy - Padova

Tel: 39-049-7625286

Netherlands - Drunen

Tel: 31-416-690399

Fax: 31-416-690340

Norway - Trondheim

Tel: 47-7288-4388

Poland - Warsaw

Tel: 48-22-3325737

Romania - Bucharest

Tel: 40-21-407-87-50

Spain - Madrid

Tel: 34-91-708-08-90

Fax: 34-91-708-08-91

Sweden - Gothenberg

Tel: 46-31-704-60-40

Sweden - Stockholm

Tel: 46-8-5090-4654

UK - Wokingham

Tel: 44-118-921-5800

Fax: 44-118-921-5820