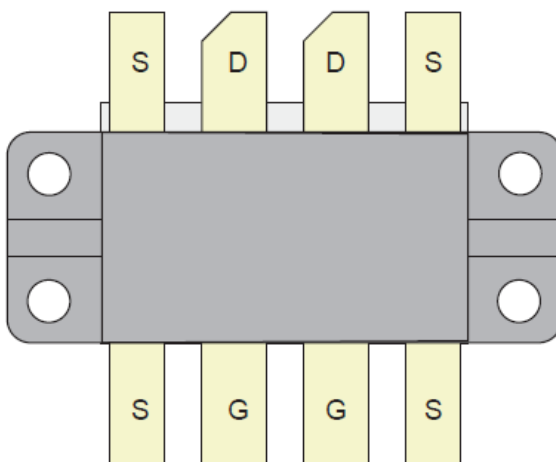

500 V, 900 W, 128 MHz RF Power MOSFET

Product Overview

The ARF476FL is a matched pair of RF power transistors in a common source configuration in a T3C package. It is designed for high-voltage push-pull or parallel operation in narrow band ISM and MRI power amplifiers up to 128 MHz.

**Features**

- Specified 500 V, 128 MHz characteristics:
 - Output power = 900 W peak
 - Gain = 15 dB (Class AB)
 - Efficiency = 50% minimum
- High-performance push-pull RF package
- High-voltage breakdown and large SOA for superior ruggedness
- Low thermal resistance
- RoHS compliant

1. Device Specifications

This section shows the specifications of the ARF476FL device.

1.1 Absolute Maximum Ratings

The following table shows the absolute maximum ratings of the ARF476FL device. $T_C = 25\text{ }^\circ\text{C}$ unless otherwise specified.

Table 1-1. Absolute Maximum Ratings

Symbol	Parameter	Ratings	Unit
V_{DSS}	Drain-source voltage	500	V
V_{DGO}	Drain-gate voltage	500	
I_D	Continuous drain current	10	A
V_{GS}	Gate-source voltage	± 30	V
P_D	Total power dissipation (per side)	910	W
T_J, T_{STG}	Operating and storage junction temperature range	-55 to 175	$^\circ\text{C}$
T_L	Lead temperature: 0.063" from case for 10 seconds	300	

1.2 Electrical Performance

The following table shows the static characteristics of the ARF476FL device. $T_C = 25\text{ }^\circ\text{C}$ unless otherwise specified.

Table 1-2. Static Characteristics

Symbol	Characteristic	Test Conditions	Min	Typ	Max	Unit
$V_{(BR)DSS}$	Drain-source breakdown voltage	$V_{GS} = 0\text{ V}, I_D = 250\text{ }\mu\text{A}$	500			V
$V_{DS(ON)}$	On-state drain voltage ¹	$I_{D(ON)} = 5\text{ A}, V_{GS} = 10\text{ V}$		2.9	4	
I_{DSS}	Zero-gate voltage drain current	$V_{DS} = V_{DSS}, V_{GS} = 0\text{ V}$			100	μA
		$V_{DS} = 50\text{ V}, V_{GS} = 0\text{ V}, T_C = 125\text{ }^\circ\text{C}$			500	
I_{GSS}	Gate-source leakage current	$V_{GS} = \pm 30\text{ V}, V_{DS} = 0\text{ V}$			± 100	nA
g_{fs}	Forward transconductance	$V_{DS} = 15\text{ V}, I_D = 5\text{ A}$	4.2	5.1		S
g_{fs1}/g_{fs2}	Forward transconductance match ratio	$V_{DS} = 15\text{ V}, I_D = 5\text{ A}$	0.9		1.1	S
$V_{GS(th)}$	Gate-source threshold voltage	$V_{DS} = V_{GS}, I_D = 200\text{ mA}$	2	3.3	4	V
$DV_{GS(th)}$	Gate threshold voltage match	$V_{DS} = V_{GS}, I_D = 200\text{ mA}$			0.2	V

Note:

1. Pulse test: Pulse width < 380 μs , Duty Cycle < 2%.

The following table shows the thermal characteristics of the ARF476FL device.

Table 1-3. Thermal Characteristics (per side)

Symbol	Characteristic	Min	Typ	Max	Unit
$R_{\theta JC}$	Junction-to-case thermal resistance		0.15	0.165	°C/W
$R_{\theta JHS}$	Junction-to-sink thermal resistance (Use high-efficiency thermal grease and planar heat sink surface.)		0.30	0.33	

The following table shows the dynamic characteristics of the ARF476FL device. $T_C = 25\text{ }^\circ\text{C}$ unless otherwise specified.

Table 1-4. Dynamic Characteristics (per Section)

Symbol	Characteristic	Test Conditions	Min	Typ	Max	Unit
C_{iss}	Input capacitance	$V_{GS} = 0\text{ V}, V_{DS} = 50\text{ V}, f = 1\text{ MHz}$		740	830	pF
C_{oss}	Output capacitance			125	130	
C_{rss}	Reverse transfer capacitance			7	9	
$t_{d(on)}$	Turn-on delay time	$V_{GS} = 15\text{ V}, V_{DD} = 250\text{ V}, I_D = I_{D[Cont.]}$ at $25\text{ }^\circ\text{C}$, $R_g = 1.6\text{ }\Omega$		5.1	10	ns
t_r	Rise time			4.1	8	
$t_{d(off)}$	Turn-off delay time			12	18	
t_f	Fall time			4.0	7	

The following table shows the functional characteristics of the ARF476FL device. $T_C = 25\text{ }^\circ\text{C}$ unless otherwise specified.

Table 1-5. Functional Characteristics (Push-Pull Configuration)

Parameter	Characteristic	Test Conditions	Min	Typ	Max	Unit
G_{PS}	Common source amplifier power gain	$f = 128\text{ MHz}, V_{DD} = 150\text{ V}, I_{DQ} = 15\text{ mA}, P_{out} = 900\text{ W}, PW = 3\text{ ms}, 10\%$ duty cycle	14	16		dB
η	Drain efficiency		50	55		
Ψ	Electrical ruggedness VSWR 5:1		No degradation in output power			

1.3 Typical Performance Curves

This section shows the typical performance curves of the ARF476FL device per transistor section unless otherwise specified.

Figure 1-1. Output Characteristics

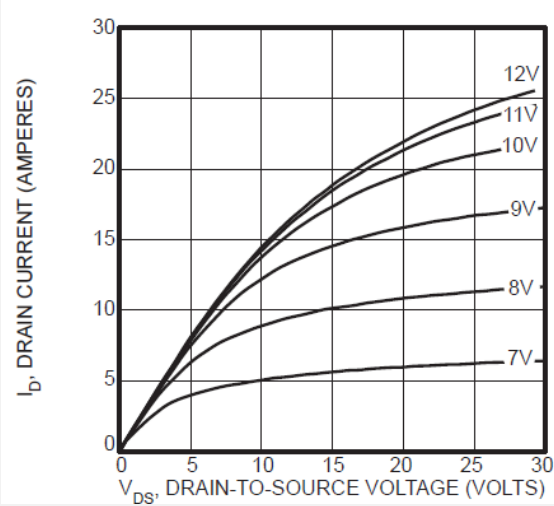

Figure 1-2. Capacitance vs. Drain-to-Source Voltage

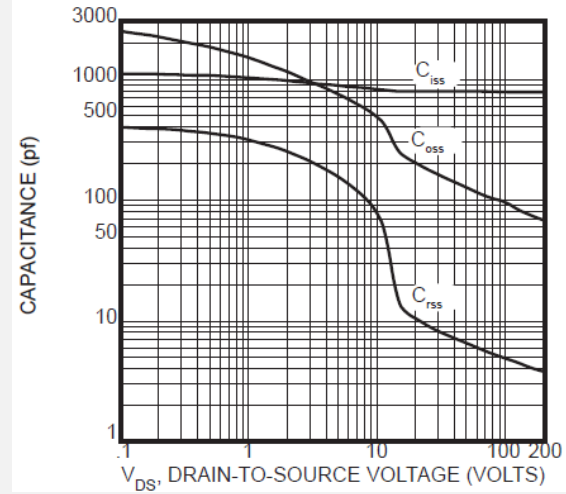

Figure 1-3. Transfer Characteristics

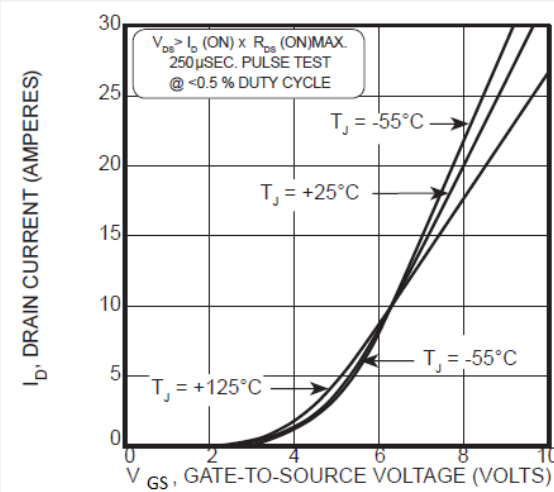

Figure 1-4. Threshold Voltage vs. Temperature

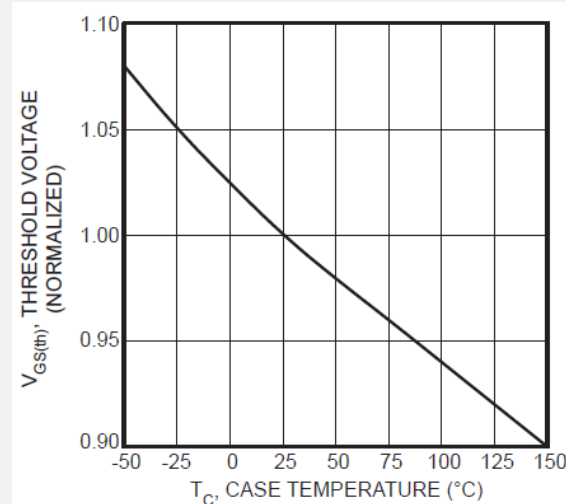

Figure 1-5. Maximum Effective Transient Thermal Impedance Junction-to-Case vs. Pulse Duration

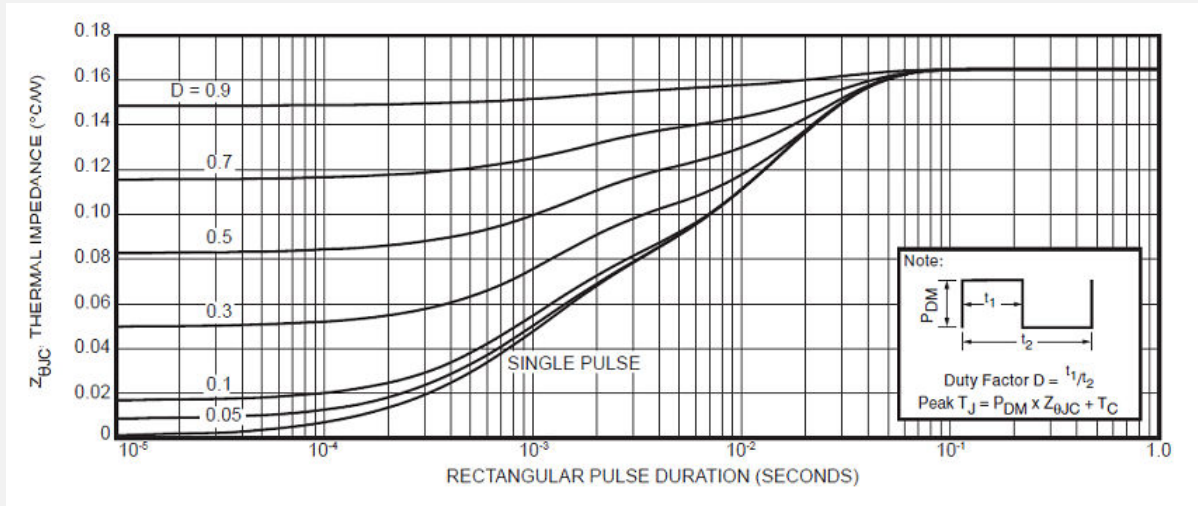

Figure 1-6. Transient Thermal Impedance Model

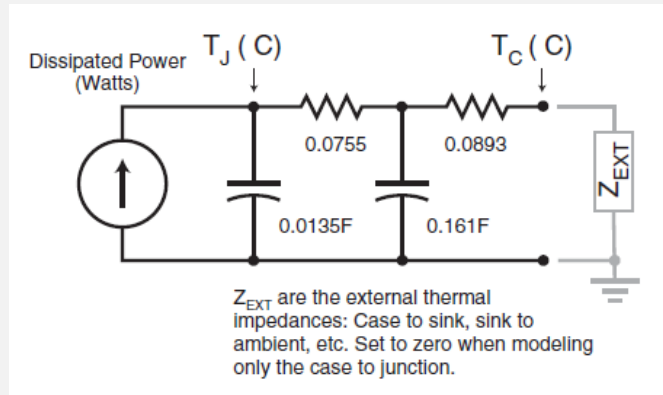
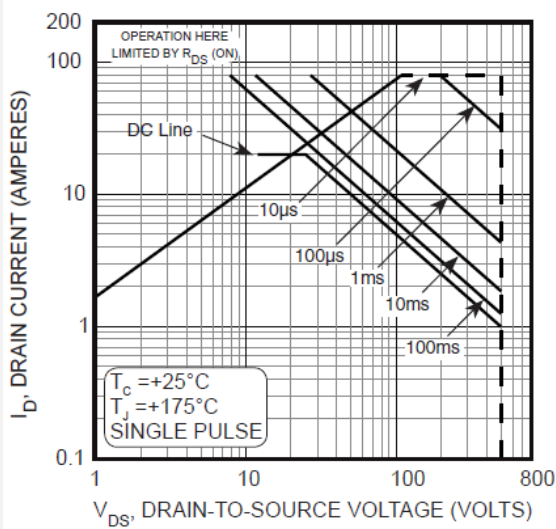

Figure 1-7. Maximum Safe Operating Area



The following table shows the typical Class AB large signal input-output impedance for the ARF476FL device.

Table 1-6. Typical Class AB Large Signal Input–Output Impedance

Frequency (MHz)	Z_{in} Ω Gate-to-Gate	Z_{out} Ω Drain-to-Drain
30	$5.2 - j 10$	$41 - j 20$
60	$1.37 - j 5.2$	$26 - j 25$
90	$0.53 - j 2.6$	$16 - j 23$
120	$0.25 - j 1.0$	$10 - j 20$
150	$0.25 + j 0.2$	$6.7 - j 17$

Notes:

- Z_{in} — Gate shunted with 25 Ω
- $I_{DQ} = 15$ mA each side
- Z_{out} — Conjugate of optimum load for 600 W peak output at $V_{DD} = 150$ V, 25% duty cycle and $PW = 5$ ms

2. Test Circuits

The following figure shows the test circuit of the ARF476FL device.

Figure 2-1. 128 MHz Test Circuit

128MHz Test amplifier
 $P_o = 900W @ 150V$
 3ms pulse 10% Duty Cycle

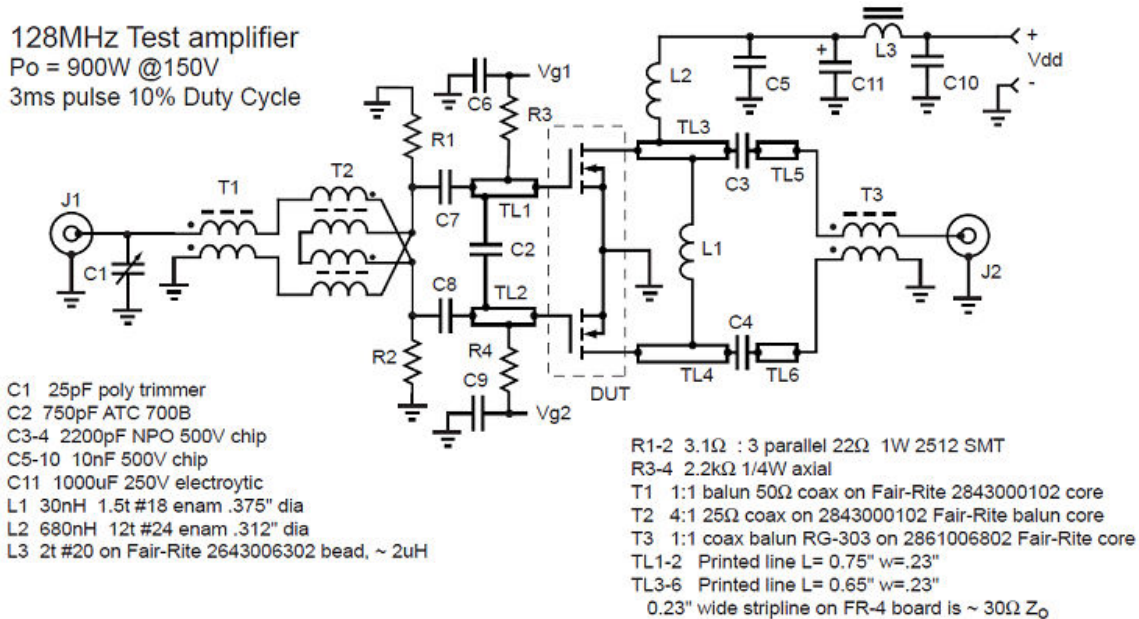

The following image shows the peak output power versus V_{dd} and duty cycle.

Figure 2-2. Peak Output Power vs. V_{dd} and Duty Cycle

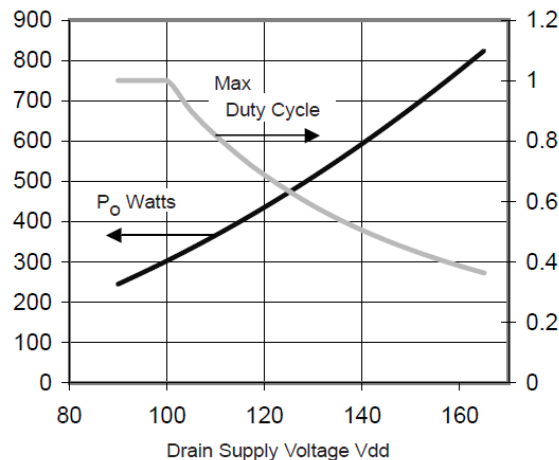

Note: The value of L1 must be adjusted as the supply voltage is changed to maintain resonance in the output circuit. At 128 MHz its value changes from approximately 40 nH at 100 V, to 30 nH at 150 V.

With the 50 Ω drain-to-drain load, the duty cycle above 100 V must be reduced to ensure power dissipation is within the limits of the device. Maximum pulse length should be 100 ms or less.

3. Package Specification

This section shows the package specification of the ARF476FL device.

3.1 Package Outline Drawing

The following figure illustrates the package outline of the ARF476FL device.

Figure 3-1. T3C Package Outline

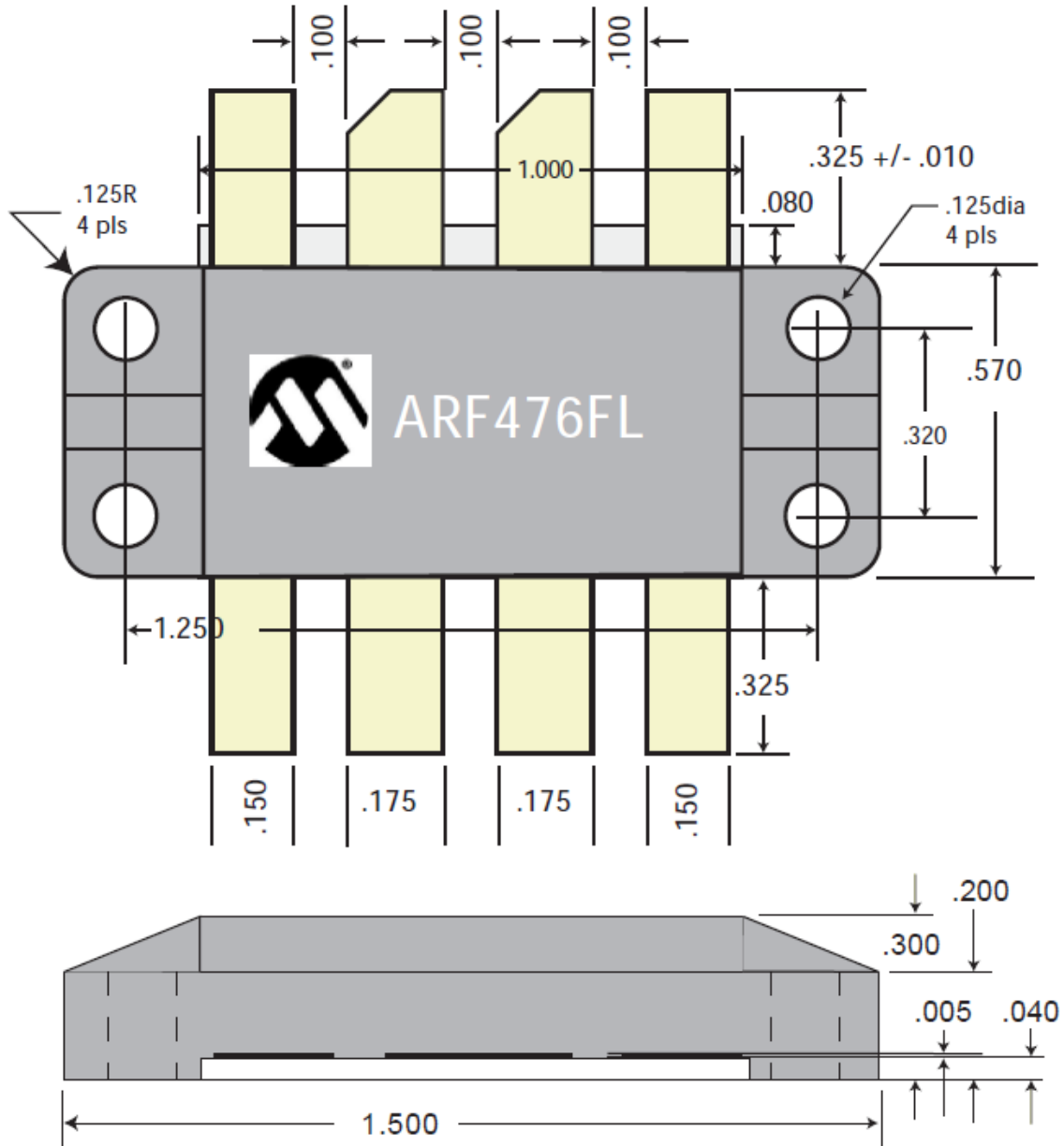

Note: Hazardous Material Warning!

The white ceramic portion of the device between leads and mounting flange is beryllium oxide. Beryllium oxide dust is highly toxic when inhaled. Care must be taken during handling and mounting to avoid damage to this area. These devices must never be thrown away with general industrial or domestic waste.

Note: These devices are sensitive to electrostatic discharge. Proper handling procedures should be followed.

Thermal Considerations and Package Mounting

The rated power dissipation is only available when the package mounting surface is at 25 °C and the junction temperature is 175 °C. The thermal resistance between junctions and case mounting surface is 0.16 °C/W. When installed, an additional thermal impedance of 0.15 °C/W between the package base and the mounting surface is typical. Ensure that the mounting surface is smooth and flat. Thermal joint compound must be used to reduce the effects of small surface irregularities. Use the minimum amount necessary to coat the surface. The heat sink should incorporate a copper heat spreader to obtain best results.

The package design clamps the ceramic base to the heat sink. A clamped joint maintains the required mounting pressure while allowing for thermal expansion of both the base and the heat sink. Four 4-40 (M3) screws provide the required mounting force. T = 3-4 in-lb (0.34 - 0.45 N-m).

4. Revision History

Table 4-1. Revision History

Revision	Date	Description
A	12/2021	<ul style="list-style-type: none"> • Document migrated from Microsemi template to Microchip template; Assigned Microchip literature number DS-00004436A, which replaces the previous Microsemi literature number 050-4931. • Changed g_{fs} minimum value from 3 to 4.2 and typical from 3.6 to 5.1 (changed unit from MHOS to S).
Initial releases (Microsemi Revisions A through E)	02/2006 – 12/2010	Previous releases.

The Microchip Website

Microchip provides online support via our website at www.microchip.com/. This website is used to make files and information easily available to customers. Some of the content available includes:

- **Product Support** – Data sheets and errata, application notes and sample programs, design resources, user's guides and hardware support documents, latest software releases and archived software
- **General Technical Support** – Frequently Asked Questions (FAQs), technical support requests, online discussion groups, Microchip design partner program member listing
- **Business of Microchip** – Product selector and ordering guides, latest Microchip press releases, listing of seminars and events, listings of Microchip sales offices, distributors and factory representatives

Product Change Notification Service

Microchip's product change notification service helps keep customers current on Microchip products. Subscribers will receive email notification whenever there are changes, updates, revisions or errata related to a specified product family or development tool of interest.

To register, go to www.microchip.com/pcn and follow the registration instructions.

Customer Support

Users of Microchip products can receive assistance through several channels:

- Distributor or Representative
- Local Sales Office
- Embedded Solutions Engineer (ESE)
- Technical Support

Customers should contact their distributor, representative or ESE for support. Local sales offices are also available to help customers. A listing of sales offices and locations is included in this document.

Technical support is available through the website at: www.microchip.com/support

Microchip Devices Code Protection Feature

Note the following details of the code protection feature on Microchip products:

- Microchip products meet the specifications contained in their particular Microchip Data Sheet.
- Microchip believes that its family of products is secure when used in the intended manner, within operating specifications, and under normal conditions.
- Microchip values and aggressively protects its intellectual property rights. Attempts to breach the code protection features of Microchip product is strictly prohibited and may violate the Digital Millennium Copyright Act.
- Neither Microchip nor any other semiconductor manufacturer can guarantee the security of its code. Code protection does not mean that we are guaranteeing the product is "unbreakable". Code protection is constantly evolving. Microchip is committed to continuously improving the code protection features of our products.

Legal Notice

This publication and the information herein may be used only with Microchip products, including to design, test, and integrate Microchip products with your application. Use of this information in any other manner violates these terms. Information regarding device applications is provided only for your convenience and may be superseded by updates. It is your responsibility to ensure that your application meets with your specifications. Contact your local Microchip sales office for additional support or, obtain additional support at www.microchip.com/en-us/support/design-help/client-support-services.

THIS INFORMATION IS PROVIDED BY MICROCHIP "AS IS". MICROCHIP MAKES NO REPRESENTATIONS OR WARRANTIES OF ANY KIND WHETHER EXPRESS OR IMPLIED, WRITTEN OR ORAL, STATUTORY OR OTHERWISE, RELATED TO THE INFORMATION INCLUDING BUT NOT LIMITED TO ANY IMPLIED WARRANTIES OF NON-INFRINGEMENT, MERCHANTABILITY, AND FITNESS FOR A PARTICULAR PURPOSE, OR WARRANTIES RELATED TO ITS CONDITION, QUALITY, OR PERFORMANCE.

IN NO EVENT WILL MICROCHIP BE LIABLE FOR ANY INDIRECT, SPECIAL, PUNITIVE, INCIDENTAL, OR CONSEQUENTIAL LOSS, DAMAGE, COST, OR EXPENSE OF ANY KIND WHATSOEVER RELATED TO THE INFORMATION OR ITS USE, HOWEVER CAUSED, EVEN IF MICROCHIP HAS BEEN ADVISED OF THE POSSIBILITY OR THE DAMAGES ARE FORESEEABLE. TO THE FULLEST EXTENT ALLOWED BY LAW, MICROCHIP'S TOTAL LIABILITY ON ALL CLAIMS IN ANY WAY RELATED TO THE INFORMATION OR ITS USE WILL NOT EXCEED THE AMOUNT OF FEES, IF ANY, THAT YOU HAVE PAID DIRECTLY TO MICROCHIP FOR THE INFORMATION.

Use of Microchip devices in life support and/or safety applications is entirely at the buyer's risk, and the buyer agrees to defend, indemnify and hold harmless Microchip from any and all damages, claims, suits, or expenses resulting from such use. No licenses are conveyed, implicitly or otherwise, under any Microchip intellectual property rights unless otherwise stated.

Trademarks

The Microchip name and logo, the Microchip logo, Adaptec, AnyRate, AVR, AVR logo, AVR Freaks, BesTime, BitCloud, CryptoMemory, CryptoRF, dsPIC, flexPWR, HELDO, IGLOO, JukeBlox, KeeLoq, Klear, LANCheck, LinkMD, maXStylus, maXTouch, MediaLB, megaAVR, Microsemi, Microsemi logo, MOST, MOST logo, MPLAB, OptoLyzer, PIC, picoPower, PICSTART, PIC32 logo, PolarFire, Prochip Designer, QTouch, SAM-BA, SenGenuity, SpyNIC, SST, SST Logo, SuperFlash, Symmetricom, SyncServer, Tachyon, TimeSource, tinyAVR, UNI/O, Vectron, and XMEGA are registered trademarks of Microchip Technology Incorporated in the U.S.A. and other countries.

AgileSwitch, APT, ClockWorks, The Embedded Control Solutions Company, EtherSynch, Flashtec, Hyper Speed Control, HyperLight Load, IntellIMOS, Libero, motorBench, mTouch, Powermite 3, Precision Edge, ProASIC, ProASIC Plus, ProASIC Plus logo, Quiet- Wire, SmartFusion, SyncWorld, Temux, TimeCesium, TimeHub, TimePictra, TimeProvider, TrueTime, WinPath, and ZL are registered trademarks of Microchip Technology Incorporated in the U.S.A.

Adjacent Key Suppression, AKS, Analog-for-the-Digital Age, Any Capacitor, AnyIn, AnyOut, Augmented Switching, BlueSky, BodyCom, CodeGuard, CryptoAuthentication, CryptoAutomotive, CryptoCompanion, CryptoController, dsPICDEM, dsPICDEM.net, Dynamic Average Matching, DAM, ECAN, Espresso T1S, EtherGREEN, GridTime, IdealBridge, In-Circuit Serial Programming, ICSP, INICnet, Intelligent Paralleling, Inter-Chip Connectivity, JitterBlocker, Knob-on-Display, maxCrypto, maxView, memBrain, Mindi, MiWi, MPASM, MPF, MPLAB Certified logo, MPLIB, MPLINK, MultiTRAK, NetDetach, NVM Express, NVMe, Omniscient Code Generation, PICDEM, PICDEM.net, PICkit, PICtail, PowerSmart, PureSilicon, QMatrix, REAL ICE, Ripple Blocker, RTAX, RTG4, SAM-ICE, Serial Quad I/O, simpleMAP, SimpliPHY, SmartBuffer, SmartHLS, SMART-I.S., storClad, SQL, SuperSwitcher, SuperSwitcher II, Switchtec, SynchroPHY, Total Endurance, TSHARC, USBCheck, VariSense, VectorBlox, VeriPHY, ViewSpan, WiperLock, XpressConnect, and ZENA are trademarks of Microchip Technology Incorporated in the U.S.A. and other countries.

SQTP is a service mark of Microchip Technology Incorporated in the U.S.A.

The Adaptec logo, Frequency on Demand, Silicon Storage Technology, Symmcom, and Trusted Time are registered trademarks of Microchip Technology Inc. in other countries.

GestIC is a registered trademark of Microchip Technology Germany II GmbH & Co. KG, a subsidiary of Microchip Technology Inc., in other countries.

All other trademarks mentioned herein are property of their respective companies.

© 2022, Microchip Technology Incorporated and its subsidiaries. All Rights Reserved.

ISBN: 978-1-5224-9736-3

Quality Management System

For information regarding Microchip's Quality Management Systems, please visit www.microchip.com/quality.

Worldwide Sales and Service

AMERICAS	ASIA/PACIFIC	ASIA/PACIFIC	EUROPE
<p>Corporate Office 2355 West Chandler Blvd. Chandler, AZ 85224-6199 Tel: 480-792-7200 Tel: 480-792-7277 Technical Support: www.microchip.com/support Web Address: www.microchip.com</p> <p>Atlanta Duluth, GA Tel: 678-957-9614 Fax: 678-957-1455</p> <p>Austin, TX Tel: 512-257-3370</p> <p>Boston Westborough, MA Tel: 774-760-0087 Fax: 774-760-0088</p> <p>Chicago Itasca, IL Tel: 630-285-0071 Fax: 630-285-0075</p> <p>Dallas Addison, TX Tel: 972-818-7423 Fax: 972-818-2924</p> <p>Detroit Novi, MI Tel: 248-848-4000</p> <p>Houston, TX Tel: 281-894-5983</p> <p>Indianapolis Noblesville, IN Tel: 317-773-8323 Fax: 317-773-5453 Tel: 317-536-2380</p> <p>Los Angeles Mission Viejo, CA Tel: 949-462-9523 Fax: 949-462-9608 Tel: 951-273-7800</p> <p>Raleigh, NC Tel: 919-844-7510</p> <p>New York, NY Tel: 631-435-6000</p> <p>San Jose, CA Tel: 408-735-9110 Tel: 408-436-4270</p> <p>Canada - Toronto Tel: 905-695-1980 Fax: 905-695-2078</p>	<p>Australia - Sydney Tel: 61-2-9868-6733</p> <p>China - Beijing Tel: 86-10-8569-7000</p> <p>China - Chengdu Tel: 86-28-8665-5511</p> <p>China - Chongqing Tel: 86-23-8980-9588</p> <p>China - Dongguan Tel: 86-769-8702-9880</p> <p>China - Guangzhou Tel: 86-20-8755-8029</p> <p>China - Hangzhou Tel: 86-571-8792-8115</p> <p>China - Hong Kong SAR Tel: 852-2943-5100</p> <p>China - Nanjing Tel: 86-25-8473-2460</p> <p>China - Qingdao Tel: 86-532-8502-7355</p> <p>China - Shanghai Tel: 86-21-3326-8000</p> <p>China - Shenyang Tel: 86-24-2334-2829</p> <p>China - Shenzhen Tel: 86-755-8864-2200</p> <p>China - Suzhou Tel: 86-186-6233-1526</p> <p>China - Wuhan Tel: 86-27-5980-5300</p> <p>China - Xian Tel: 86-29-8833-7252</p> <p>China - Xiamen Tel: 86-592-2388138</p> <p>China - Zhuhai Tel: 86-756-3210040</p>	<p>India - Bangalore Tel: 91-80-3090-4444</p> <p>India - New Delhi Tel: 91-11-4160-8631</p> <p>India - Pune Tel: 91-20-4121-0141</p> <p>Japan - Osaka Tel: 81-6-6152-7160</p> <p>Japan - Tokyo Tel: 81-3-6880-3770</p> <p>Korea - Daegu Tel: 82-53-744-4301</p> <p>Korea - Seoul Tel: 82-2-554-7200</p> <p>Malaysia - Kuala Lumpur Tel: 60-3-7651-7906</p> <p>Malaysia - Penang Tel: 60-4-227-8870</p> <p>Philippines - Manila Tel: 63-2-634-9065</p> <p>Singapore Tel: 65-6334-8870</p> <p>Taiwan - Hsin Chu Tel: 886-3-577-8366</p> <p>Taiwan - Kaohsiung Tel: 886-7-213-7830</p> <p>Taiwan - Taipei Tel: 886-2-2508-8600</p> <p>Thailand - Bangkok Tel: 66-2-694-1351</p> <p>Vietnam - Ho Chi Minh Tel: 84-28-5448-2100</p>	<p>Austria - Wels Tel: 43-7242-2244-39 Fax: 43-7242-2244-393</p> <p>Denmark - Copenhagen Tel: 45-4485-5910 Fax: 45-4485-2829</p> <p>Finland - Espoo Tel: 358-9-4520-820</p> <p>France - Paris Tel: 33-1-69-53-63-20 Fax: 33-1-69-30-90-79</p> <p>Germany - Garching Tel: 49-8931-9700</p> <p>Germany - Haan Tel: 49-2129-3766400</p> <p>Germany - Heilbronn Tel: 49-7131-72400</p> <p>Germany - Karlsruhe Tel: 49-721-625370</p> <p>Germany - Munich Tel: 49-89-627-144-0 Fax: 49-89-627-144-44</p> <p>Germany - Rosenheim Tel: 49-8031-354-560</p> <p>Israel - Ra'anana Tel: 972-9-744-7705</p> <p>Italy - Milan Tel: 39-0331-742611 Fax: 39-0331-466781</p> <p>Italy - Padova Tel: 39-049-7625286</p> <p>Netherlands - Drunen Tel: 31-416-690399 Fax: 31-416-690340</p> <p>Norway - Trondheim Tel: 47-72884388</p> <p>Poland - Warsaw Tel: 48-22-3325737</p> <p>Romania - Bucharest Tel: 40-21-407-87-50</p> <p>Spain - Madrid Tel: 34-91-708-08-90 Fax: 34-91-708-08-91</p> <p>Sweden - Gothenberg Tel: 46-31-704-60-40</p> <p>Sweden - Stockholm Tel: 46-8-5090-4654</p> <p>UK - Wokingham Tel: 44-118-921-5800 Fax: 44-118-921-5820</p>