

MD-013 ULTRA CLEAN

GNSS (GPS, GLONASS, Galileo)

Disciplined Oscillator Module



Summary

The MD-013 ULTRA CLEAN GNSS Disciplined Oscillator Module features ultra-low phase noise and ultra-low Allan Deviation (ADEV). The module has an embedded 72-channel GNSS receiver for GPS, Galileo and GLONASS services, and it can be configured to use an external reference. The module's ultra-low-phase-noise/ultra-low ADEV reference quartz crystal oscillator is disciplined to the external reference input's GNSS receiver.

Features

- Embedded GNSS receiver—GPS, Galileo, GLONASS
- 1 PPS TTL output signal
- 10 MHz sine wave and square wave outputs
- Adaptive aging correction during holdover
- Barometric pressure correction
- Serial communications interface
- NMEA 0183 V4.1
- Evaluation kit with software

Applications



Airborne



Vehicle Platforms



Radar Systems



LTE and LTE Advanced (LTE-A)



Laboratory Testing



Base Stations



MILSATCOM



Navigation and Position Systems



Radio Communications



UAV/UAS



Manufacturing Testing



Time Synchronization

Functional Block Diagram

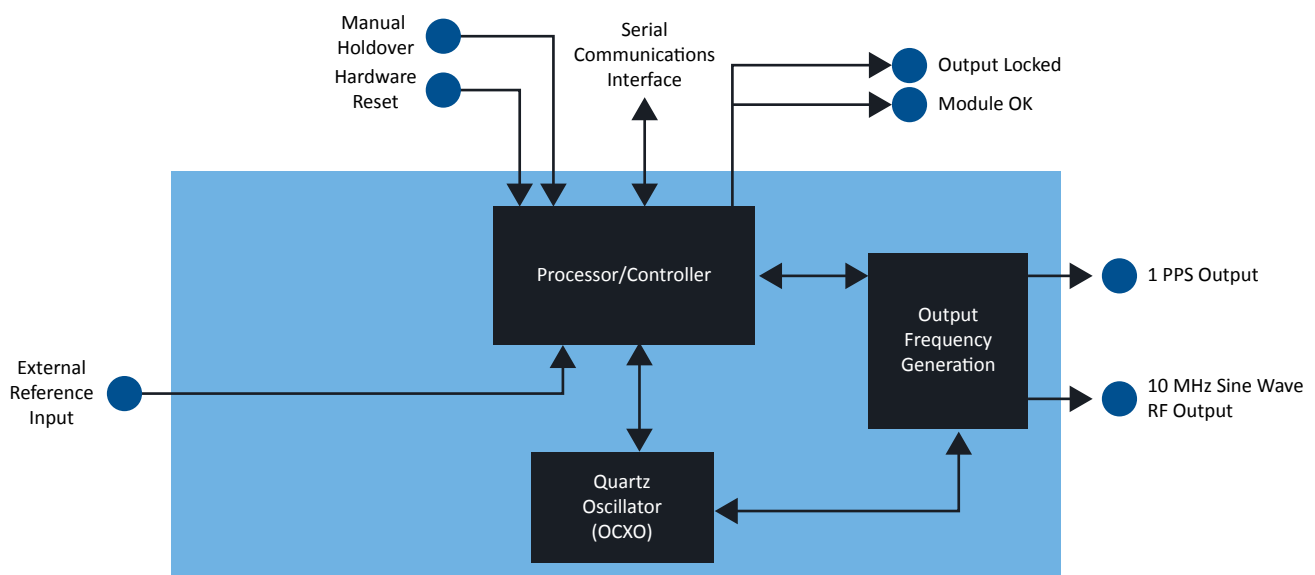

Summary Specifications

Comparative Performance of Standard Modules

| Model | Embedded Oscillator | Typical Uses |
|--------------------|-------------------------|---|
| MD-013 ULTRA CLEAN | Digitally assisted OCXO | Applications requiring low holdover performance |

Holdover Performance¹

| Holdover Time | 10 Minutes | 1 Hour | 1 Hour | 24 Hours |
|--|--------------------------------|--------------------------------|---------------------------------|--------------------------------|
| Holdover Temperature Change | $\Delta T = 2^{\circ}\text{C}$ | $\Delta T = 2^{\circ}\text{C}$ | $\Delta T = 10^{\circ}\text{C}$ | $\Delta T = 2^{\circ}\text{C}$ |
| Maximum Accumulated Holdover (μs) | 0.05 | 0.24 | 0.4 | 4.0 |

Summary Performance Characteristics

| Warmup Time (Min) | Aging/Day (ppb) ¹ | Temperature Stability (ppb) ¹ | Accuracy to UTC (+/-1 σ) (ns) ² | Frequency Accuracy (+/-) ³ | Warmup Power @ 25°C (W) | Steady State Power @ 25°C (W) | Voltage (V) |
|-------------------|------------------------------|--|--|---------------------------------------|-------------------------|-------------------------------|-------------|
| 7 | 0.2 | 1.0 | 10 | < 1E-12 | 11.0 | 5.0 | 12 |

| Phase Noise | | | | | |
|-------------|-------------|-------------|-------------|-------------|-------------|
| -1 Hz | -10 Hz | -100 Hz | -1 kHz | -10 kHz | -100 kHz |
| -119 dBc/Hz | -140 dBc/Hz | -155 dBc/Hz | -160 dBc/Hz | -164 dBc/Hz | -165 dBc/Hz |

| Allen Deviation (ADEV) and Hadamard Deviation (HDEV) | | | | | |
|--|--------|---------|----------|-----------|----------------------------------|
| Parameter | t = 1s | t = 10s | t = 100s | t = 1000s | Condition |
| ADEV (Locking) | 3E-13 | 6E-13 | 9E-13 | 20E-13 | Still air, no temperature change |
| ADEV (Holdover) | 3E-13 | 6E-13 | 9E-13 | 50E-13 | |
| HDEV (Locking) | N/A | 5E-13 | 8E-13 | 12E-13 | |
| HDEV (Holdover) | N/A | 5E-13 | 8E-13 | 20E-13 | |

| GPS Antenna Specifications | | | | | |
|------------------------------|-----|---------|-----|-------|-----------|
| Parameter | Min | Typical | Max | Units | Condition |
| Antenna Bias Voltage | 4.0 | 4.8 | 5.1 | VDC | |
| Antenna Current ³ | | 20 | 100 | mA | |

RF Output Waveform Characteristics (via MCX)

| Parameter | Min | Typical | Max | Units | Condition |
|--------------|-----------|---------|-------|-------|-----------|
| Waveform | Sine wave | | | | |
| Output Power | +3.0 | +9.0 | +11.0 | dBm | 50 Ohms |
| Harmonics | | | -30 | dBc | 50 Ohms |
| Spurious | | | -70 | dBc | 50 Ohms |

RF Output Waveform Characteristics (via Pin 8)

| Parameter | Min | Typical | Max | Units | Condition |
|---------------------------------|-------|---------|-----|-------|---------------|
| Waveform | HCMOS | | | | |
| High-Level Output Voltage (VOH) | 4.0 | | 5.0 | VDC | < 0.5 mA load |
| Low-Level Output Voltage (VOL) | | 0.0 | 0.4 | VDC | < 0.5 mA load |
| Rise/Fall Time | | 3 | 5 | ns | 15 pF |
| Duty Cycle | 40 | 50 | 60 | % | 15 pF |

1 PPS Output Characteristics (via MCX and Pin 2)

| Parameter | Min | Typical | Max | Units | Condition |
|---------------------------------|-----|---------|------|-------|------------------------------------|
| Waveform | TTL | | | | |
| High-Level Output Voltage (VOH) | 3.0 | | 5.0 | VDC | 50 Ohms |
| Low-Level Output Voltage (VOL) | | 0.0 | 0.4 | VDC | 50 Ohms |
| Pulse Width | 9.9 | 10 | 10.1 | μs | Default setting, user programmable |

External 1 PPS Reference Input (Pin 1)

| Parameter | Min | Typical | Max | Units | Condition |
|---------------------------------|-----|---------|-----|-------|-------------------------|
| Waveform | TTL | | | | |
| High-Level Output Voltage (VOH) | 2.0 | | 5.0 | VDC | 50 Ohms input impedance |
| Low-Level Output Voltage (VOL) | | 0.0 | 0.4 | VDC | |
| Pulse Width | 10 | | | μs | |

Lock Status Indicator (Pin 9)⁴

| Parameter | Min | Typical | Max | Units | Condition |
|-------------------|-----|---------|-----|-------|-------------|
| Module Locked | 4.5 | 5.0 | 5.5 | VDC | < 5 mA load |
| Module Not Locked | 0 | | 0.5 | VDC | < 5 mA load |

Module Hardware OK Indicator (Pin 10)⁵

| Parameter | Min | Typical | Max | Units | Condition |
|-------------------------|-----|---------|-----|-------|-------------|
| Module Hardware OK | 4.5 | 5.0 | 5.5 | VDC | < 5 mA load |
| Module Hardware Failure | 0 | | 0.5 | VDC | < 5 mA load |

Module Hardware Reset (Pin 12)

| Parameter | Min | Typical | Max | Units | Condition |
|--------------|-----|---------|-----|-------|-------------------------|
| Reset Module | 0 | | 0.5 | VDC | 10 kOhm internal pullup |

Module Holdover Reset (Pin 11)

| Parameter | Min | Typical | Max | Units | Condition |
|-----------------------|-----|---------|-----|-------|--------------------------|
| Enter Manual Holdover | 0 | | 0.5 | VDC | 5.6 kOhm internal pullup |

Serial Communications Interface^{6,7}

| Parameter | Min | Typical | Max | Units | Condition |
|------------------------------------|------------------------|------------------------------|-----|-------|-------------------|
| Rx High-Level Input Voltage (VIH) | 4.5 | 5.0 | 5.5 | VDC | |
| Rx Low-Level Input Voltage (VIL) | 0 | | 0.5 | VDC | |
| Tx High-Level Output Voltage (VOH) | 4.5 | 5.0 | 5.5 | VDC | |
| Tx Low-Level Output Voltage (VOL) | 0 | | 0.5 | VDC | |
| Update Rate | 1 | | 255 | S | User configurable |
| Communications Protocol | VSIP2.1/NMEA 0183 V4.1 | See VSIP2.1 for full details | | | |

| Supply Voltage (Pin 7, 15, 16) | | | | | |
|--------------------------------|-------|---------|-------|-------|-----------|
| Parameter | Min | Typical | Max | Units | Condition |
| Supply Voltage | +11.4 | +12 | +12.6 | VDC | |

| Absolute Maximum Ratings | | | | | |
|---------------------------|------|---------|-----|-----------------|----------------|
| Parameter | Min | Typical | Max | Units | Condition |
| Supply Voltage | | | 15 | VDC | |
| DC Voltage on Any I/O Pin | -0.5 | | 5.5 | V | |
| Output Load | 10 | | | Ohms | |
| AC Ripple | | | 50 | mV peak to peak | 10 Hz to 1 MHz |

Internal Receiver Characteristics

| Parameter | Value | Condition |
|--|-------------------------|--|
| Type | Timing with self-survey | |
| Number of Channels | 72 | |
| Frequency Bands | GPS L1C/A | |
| | GLONASS L1OF | |
| | Galileo E1B/C | |
| | QZSS L1C/A | |
| | SBAS L1C/A | WAAS, EGNOS, MSAS, GAGAN (Disabled by default) |
| Tracking Capability | 36 SVs | |
| Sensitivity | -167 dBm | Tracking (GPS and GLONASS) |
| | -148 dBm | Cold acquisition (GPS and GLONASS) |
| | -160 dBm | Reacquisition (GPS and GLONASS) |
| Position Accuracy | 2.5m CEP | GPS and GLONASS, static, -130 dBm, > 6 SVs |
| TTFF | 25s | Cold start (GPS and GLONASS) |
| Maximum Navigation Update Rate (User Configurable) | 10 Hz | Single-GNSS |
| | 4 Hz | Multi-GNSS |
| Maximum Velocity | 500 m/s | |
| Maximum Altitude | 50,000m | |
| Maximum Dynamic Acceleration | 4g | |
| Timing Accuracy ² | 20 ns | 1-sigma, fixed position mode, ideal conditions |

| Environmental Conditions | | | | | |
|--------------------------|-----|---------|------|-------|-----------|
| Parameter | Min | Typical | Max | Units | Condition |
| Operating Temperature | -40 | | +85 | °C | |
| Humidity at 40°C | | | 90 | % | |
| Storage Temperature | -45 | | +105 | °C | |

| Physical Characteristics | | | | | |
|--------------------------|-----|---------|-----|-------|-----------|
| Parameter | Min | Typical | Max | Units | Condition |
| Weight | | | 120 | g | |

Microchip qualification includes various aging extreme temperatures, shock and vibration, temperature cycling and IR reflow simulation. The MD-013 family can meet the following qualification tests:

| Environmental Compliance | |
|-------------------------------|---|
| Parameter | Conditions |
| Mechanical Shock | MIL-STD-202, Method 213 Condition B (75G, 6 ms) |
| Mechanical Vibration | MIL-STD-202, Method 204 Condition A (5G peak, 10–400) |
| Resistance to Solvents | MIL-STD-202, Method 215 |
| Altitude | –2,500 to 27,900 feet |
| MTBF | 561,730 hrs ground benign |

Although ESD protection circuitry has been designed into the MD-013, proper precautions should be taken when handling and mounting. Microchip employs a Human Body Model (HBM) and a Charged-Device Model (CDM) for ESD susceptibility testing and design protection evaluation.

| ESD Ratings | | |
|-----------------------------|---------|--------------------------|
| Model | Minimum | Conditions |
| Human Body Model | 1,500V | MIL-STD-883, Method 3015 |
| Charged Device Model | 1,000V | JEDEC, JESD22-C101 |

Notes:

1. Aging performance is after one month of power-on time; temperature and aging rates are when device is not locked; performance is measured in still air
2. Assuming that the user has applied a cable delay correction and allowed the module to lock to GPS for 24 hours
3. Antenna overcurrent flag will be set if maximum current is exceeded as circuit has overcurrent protection
4. The Status Locked indicator indicates when the module is fully locked to a reference
5. The Hardware OK indicator indicates when the module is operating properly without any failures, including hardware, software or parameter out of range
6. The Rx pin is the serial interface input, and the Tx pin is the serial interface output
7. Serial configuration: 8 data bits, 1 stop bit, no parity, no flow control

Package Outline

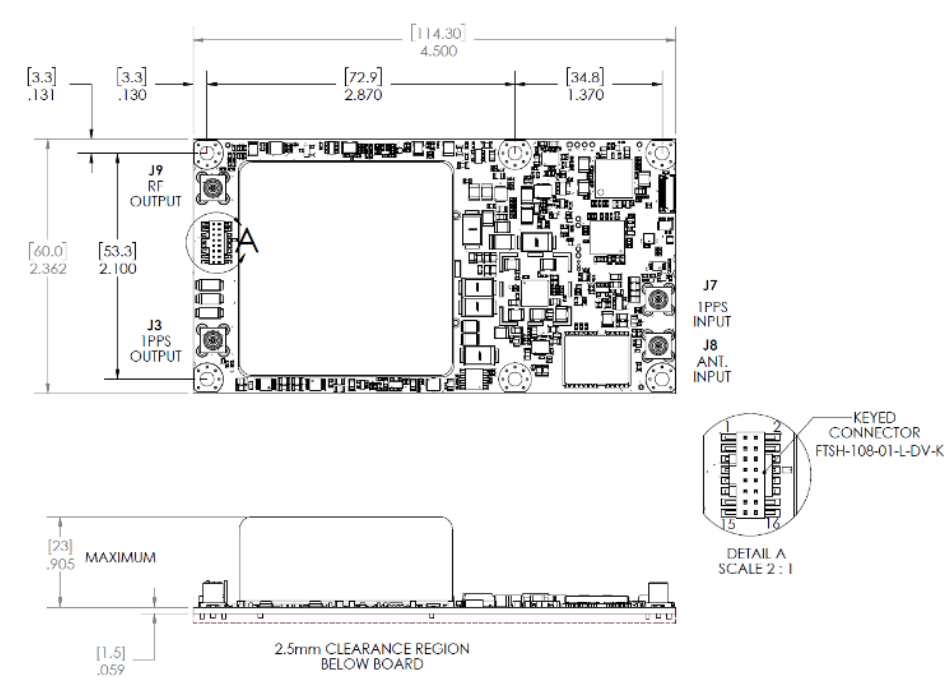

Notes:

- RF and 1 PPS input and output connectors are MCX type (SMA, SMB, MMCX connectors require additional part numbers)
- Keyed connector is Samtec FTSH-108-01-L-DV-K type
- Dimensions in [millimeters] inches
- Module height in part number is the sum of oscillator height, board and clearance

16-Pin I/O Connections

| Number | Name | Description |
|--------|-----------|---|
| 1 | Ref In | External reference input |
| 2 | PPS Out | 1 PPS output |
| 3 | Ground | Ground |
| 4 | Ground | Ground |
| 5 | Rx | Serial communication receive |
| 6 | Tx | Serial communication transmit |
| 7 | VCC | Power supply |
| 8 | RF Out | RF HCMOS output |
| 9 | Locked | Logic high = Output locked to GPS |
| 10 | Module OK | Logic low = Failure with module operation |
| 11 | ManHold | Manual holdover input |
| 12 | Reset | Hardware reset |
| 13 | Ground | Ground |
| 14 | Ground | Ground |
| 15 | VCC | Power supply |
| 16 | VCC | Power supply |

Accessories

| Microchip Part Number | Description |
|-----------------------|---|
| MD-01X_EVAL-KIT | Evaluation kit only (module must be ordered separately) |

Technical Support

North and South America

Microchip Technology Inc.
3870 North First Street San Jose, CA 95134-1702
Toll-free in North America: 1-888-367-7966, option 3
Telephone: 408-428-7907
Email: SJO-FTD.Support@microchip.com
Web: <https://microchipsupport.force.com/s/>

Europe, Middle East, and Africa

Microchip FTS EMEA
Altlaufstrasse 42
85635 Hoehenkirchen-Siegersbrunn Germany
Telephone: +49 700 3288 6435
Email: FTD.EMESupport@microchip.com
Web: <https://microchipsupport.force.com/s/>

Asia

Microchip Technology (India) Pvt. Ltd.
Phase 1, Plot No. 149/B, Block A, EPIP,
Whitefield, Industrial Area, Bengaluru,
Karnataka 560066, India
Email: SJO-FTD.Support@microchip.com
Web: <https://microchipsupport.force.com/s/>

GNSSDO-Specific Technical Support

Timing-Modules-MHS@microchip.com