

Microchip

Filter specification

TFS 365B

Measurement condition

Ambient temperature T_A : 23 °C
 Input power level: 0 dBm
 Terminating impedances at f_C *):
 input: 590 Ω// -6,6 pF
 output: 260 Ω// -5,5 pF

Characteristics

Remark:

The reference level for the relative attenuation a_{rel} of the TFS 365B is the minimum of the pass band attenuation a_{min} . The minimum of the pass band attenuation a_{min} is defined as the insertion loss a_e . The centre frequency f_C is the arithmetic mean value of the upper and lower frequencies at the 0,8 dB filter attenuation level relative to the insertion loss a_e . The nominal frequency f_N is fixed at 365 MHz without any tolerance. The given values for both the relative attenuation a_{rel} and the group delay ripple have to be achieved at the frequencies given below even if the centre frequency f_C is shifted due to the temperature coefficient of frequency TC_f in the operating temperature range and due to a production tolerance for the centre frequency f_C .

D a t a		typ. value	tolerance / limit
Insertion loss (reference level)	a_e	9 dB	max. 14,5 dB
Nominal frequency	f_N	-	365 MHz
Centre frequency at ambient temperature	f_C	365,025 MHz	-
Pass band	PB	-	$f_N \pm 0,5$ MHz
Amplitude ripple within PB		0,3 dB	max. 0,8 dB
In band ripple (in any 112,5 kHz increment within the PB)		0,15 dB	max. 0,5 dB p-p
Relative attenuation	a_{rel}		
f_N $f_N \pm 0,5$ MHz		0,3 dB	max. 0,8 dB
$f_N \pm 1,2$ MHz $f_N \pm 1,5$ MHz		40 dB	min. 35 dB
$f_N - 3,0$ MHz $f_N - 1,5$ MHz		44 dB	min. 40 dB
$f_N + 1,5$ MHz $f_N + 3,2$ MHz		43 dB	min. 40 dB
0,3 MHz $f_N - 3$ MHz		55 dB	min. 50 dB
$f_N + 3,2$ MHz 1,5 GHz		54 dB	min. 50 dB
Group delay at f_N		1,6 µs	max. 2 µs
Group delay ripple in PB (in any 112,5 kHz increment within the PB)		90 ns	max. 120 ns
Phase linearity in PB (in any 112,5 kHz increment within the PB)		1 deg p-p	max. 5 deg p-p
Input power level		-	max. 20 dBm**)
Operating temperature range		-	- 40 °C ... + 70 °C
Storage temperature range		-	- 40 °C ... + 100 °C
Turnover temperature T_o		22 °C	-
Temperature coefficient of frequency TC_f***		-0,04 ppm/K ²	-

*) The terminating impedances depend on parasitics and q-values of matching elements and the board used, and are to be understood as reference values only. Should there be additional questions, do not hesitate to ask for an application note or contact our design team.

***) This power level is only allowed for short term operation (10% of the life time), the max. input power for continuous operation is max.15dBm only

****) $\Delta f(\text{Hz}) = TC_f(\text{ppm/K}^2) \times (T - T_o)^2 \times f_{T0}(\text{MHz})$

generated:

checked / approved:

Microchip Frequency Technology GmbH
Potsdamer Straße 18
D 14 513 TELTOW / Germany
Tel: (+49) 3328 4784-0 / Fax: (+49) 3328 4784-30

Microchip Frequency Technology GmbH reserves the right to make changes to the product(s) and/or information contained herein without notice. No liability is assumed as a result of their use or application. No rights under any patent accompany the sale of any such product(s) or information.

Filter characteristic

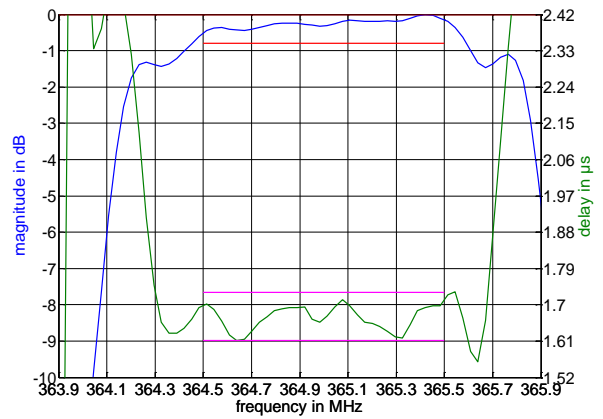
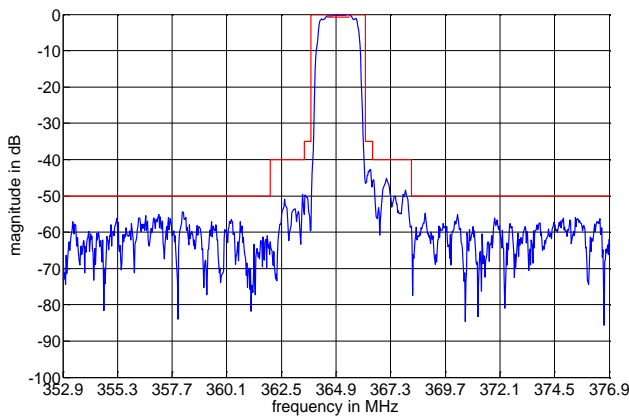

Construction and pin connection

(All dimensions in mm)

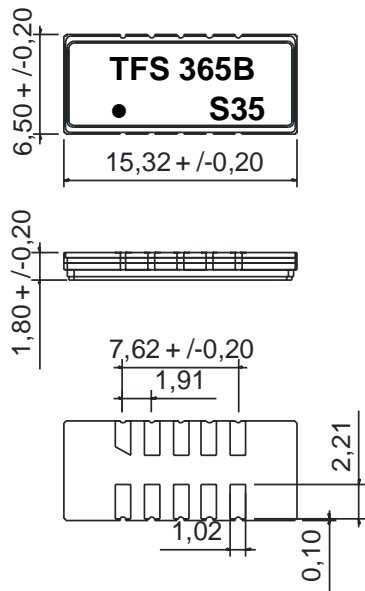

- 1 Input RF Return
- 2 Ground
- 3 Ground
- 4 Ground
- 5 Output
- 6 Output
- 7 Ground
- 8 Ground
- 9 Ground
- 10 Input

Date code: Year + week
 S 2004
 T 2005
 U 2006
 ...

50 Ω Test circuit

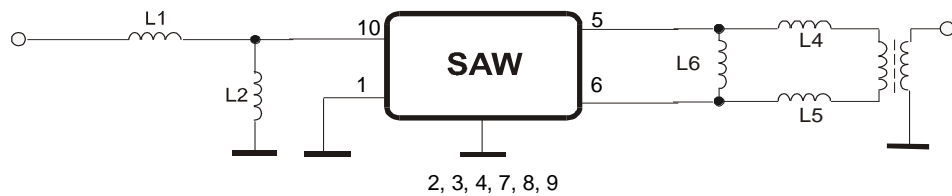

Microchip Frequency Technology GmbH
 Potsdamer Straße 18
 D 14 513 TELTOW / Germany
 Tel: (+49) 3328 4784-0 / Fax: (+49) 3328 4784-30

Microchip Frequency Technology GmbH reserves the right to make changes to the product(s) and/or information contained herein without notice. No liability is assumed as a result of their use or application. No rights under any patent accompany the sale of any such product(s) or information.

Stability Characteristics

After the following tests the filter shall meet the whole specification:

1. Shock: 500g, 18 ms, half sine wave, 3 shocks each plane;
DIN IEC 68 T2 - 27
2. Vibration: 10 Hz to 500 Hz, 0,35 mm or 5g respectively, 1 octave per min, 10 cycles per plan, 3 plans;
DIN IEC 68 T2 - 6
3. Change of temperature: -55 °C to 125°C / 30 min. each / 10 cycles
DIN IEC 68 part 2 – 14 Test N
4. Resistance to solder heat (reflow): reflow possible: twice max.;
for temperature conditions, please refer to the attached "Air reflow temperature conditions" on page 4;

Packing

Tape & Reel: IEC 286 – 3, with exception of value for N and minimum bending radius;
tape type II, embossed carrier tape with top cover tape on the upper side;

max. pieces of filters peer reel:	2000
reel of empty components at start:	min. 300 mm
reel of empty components at start including leader:	min. 500 mm
trailer:	min. 300 mm

Tape (all dimensions in mm)

- W : 24,00 ± 0,3
- Po : 4,00 ± 0,1
- Do : 1,50 +0,1/-0
- E : 1,75 ± 0,1
- F : 11,50 ± 0,1
- G(min) : 0,60
- P2 : 2,00 ± 0,1
- P1 : 12,00 ± 0,1
- D1(min) : 1,50
- Ao : 7,10 ± 0,1
- Bo : 15,90 ± 0,1
- Ct : 21,5 ± 0,1

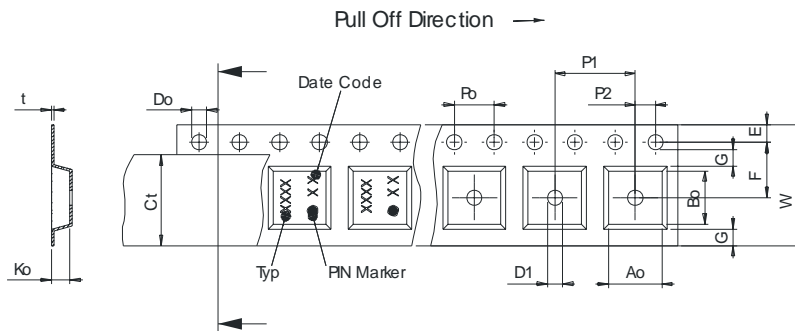

Reel (all dimensions in mm)

- A : 330
- W1 : 24,4 +2/-0
- W2(max) : 30,4
- N(min) : 60
- C : 13,0 +0,5/-0,2

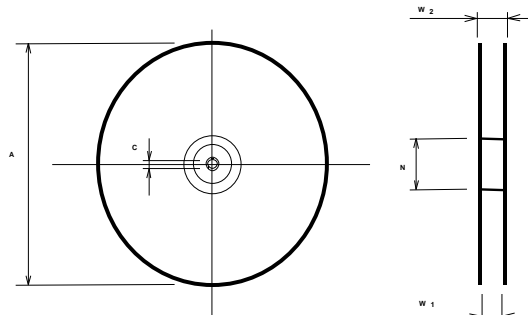

The minimum bending radius is 45 mm.

Microchip Frequency Technology GmbH
Potsdamer Straße 18
D 14 513 TELTOW / Germany
Tel: (+49) 3328 4784-0 / Fax: (+49) 3328 4784-30

Microchip Frequency Technology GmbH reserves the right to make changes to the product(s) and/or information contained herein without notice. No liability is assumed as a result of their use or application. No rights under any patent accompany the sale of any such product(s) or information.

Air reflow temperature conditions

1st and 2nd air reflow profile

Name:	pre-heating periods	main-heating periods	peak temperature
Temperature:	150 °C - 170 °C	over 200 °C	255 °C ± 5 °C
Time:	60 sec. - 90 sec.	20 sec. - 25 sec.	

Air reflow profile

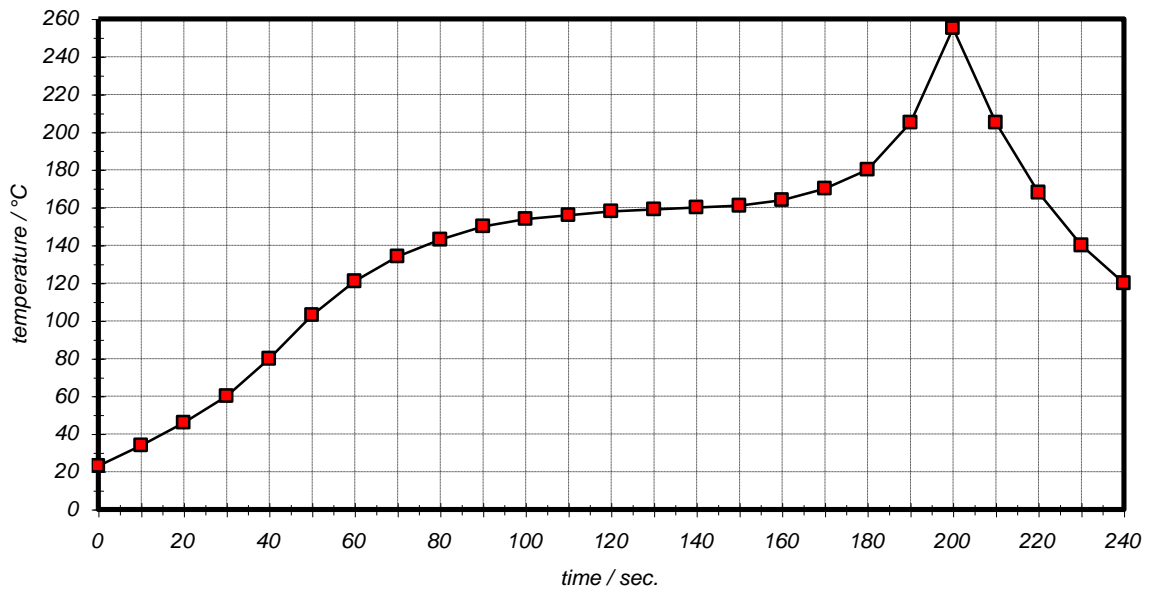

Table for temperature vs. time during the air reflow process

Tolerance of temperatures: ± 5 °C

time / sec.	temperature / °C	time / sec.	temperature / °C
0	23	140	160
10	34	150	161
20	46	160	164
30	60	170	170
40	80	180	180
50	103	190	205
60	121	195	230
70	134	200	255
80	143	205	230
90	150	210	205
100	154	215	180
110	156	220	165
120	158	230	140
130	159	240	120

Microchip Frequency Technology GmbH
Potsdamer Straße 18
D 14 513 TELTOW / Germany
Tel: (+49) 3328 4784-0 / Fax: (+49) 3328 4784-30

Microchip Frequency Technology GmbH reserves the right to make changes to the product(s) and/or information contained herein without notice. No liability is assumed as a result of their use or application. No rights under any patent accompany the sale of any such product(s) or information.

History

Version	Reason of Changes	Name	Date
1.0	Generate development specification	Roizengaft	22.12.2003
1.1	Change of relative attenuation from 39 dB to 35 dB	Dr. Wall	12.01.2004
1.2	Change of relative attenuation in between $f_c + 3\text{MHz}$ $f_c + 3,2\text{ MHz}$	Pfeiffer	16.02.2004
1.3	terminating impedance (preliminary values) and typical vales added triple transit limits removed	Pfeiffer	20.02.2004
1.4	turn over temperature, temperature coefficient and filter characteristic added	Pfeiffer	24.08.2004