

Microchip

Filter specification

TFS 110P

1/5

Measurement condition

Ambient temperature: 23°C
 Input power level: 0 dBm
 Terminating impedances at f_c *:input: 2.9 kΩ || -6.2 pF
 output: 2.8 kΩ || -5.5 pF

Characteristics

Remark:

Reference level for the relative attenuation a_{rel} of the TFS 110P is the minimum of the pass band attenuation a_{min} . The minimum of the pass band attenuation a_{min} is defined as the insertion loss a_e . The reference frequency f_c is the arithmetic mean value of the upper and lower frequencies at the 30 dB filter attenuation level relative to the insertion loss a_e .

D a t a		typ. value		tolerance / limit	
Insertion loss (reference level)	$a_e = a_{min}$	8.3	dB	10	dB
Reference frequency	f_c (30 dB-BW)	110.592	MHz	± 60	kHz
Pass band shape (3 dB-BW)		Gaussian		-	
3 dB bandwidth	BW	1110	kHz	-	
10 dB bandwidth		1695	kHz	-	
20 dB bandwidth		2255	kHz	-	
30 dB bandwidth		2600	kHz	-	
40 dB bandwidth		2820	kHz	-	
Relative attenuation					
f_c	a_{rel}	2	dB	max. 3	dB
$f_c + 475$ kHz	$\dots f_c + 475$ kHz	2	dB	max. 3	dB
$f_c - 425$ kHz	$\dots f_c - 425$ kHz	8.5	dB	max. 10	dB
$f_c + 1200$ kHz	$\dots f_c + 1200$ kHz	8	dB	max. 10	dB
$f_c - 1210$ kHz	$\dots f_c - 1210$ kHz	25	dB	min. 20	dB
$f_c + 1375$ kHz	$\dots f_c + 1375$ kHz	23	dB	min. 20	dB
$f_c - 1395$ kHz	$\dots f_c - 1395$ kHz	36	dB	min. 30	dB
$f_c + 1500$ kHz	$\dots f_c + 1500$ kHz	36	dB	min. 30	dB
$f_c + 5$ MHz	$\dots f_c + 5$ MHz	43	dB	min. 35	dB
$f_c - 1535$ kHz	$\dots f_c - 1535$ kHz	45	dB	min. 30	dB
	$\dots f_c - 10$ MHz	42	dB	min. 40	dB
Group delay ripple within $f_c \pm 576$ kHz		250	ns	max. 400	ns
Temperature coefficient of frequency TC_f **		-0.04	ppm/K ²	-	
Frequency inversion temperature T_o		25	°C		
Operating temperature range				- 20 °C ... + 70 °C	
Storage temperature range				- 40 °C ... + 85 °C	
Input power level				max. 10 dBm	

*) The terminating impedances depend on parasitics and q-values of matching elements and the board used, and are to be understood as reference values only. Should there be additional questions, do not hesitate to ask for an application note or contact our design team

***) $\Delta f(\text{Hz}) = TC_f(\text{ppm/K}^2) \times (T - T_o)^2 \times f_{T_o}(\text{MHz})$

Generated:

Checked / approved:

Microchip Frequency Technology GmbH
Potsdamer Straße 18
D 14 513 TELTOW / Germany
Tel: (+49) 3328 4784-0 / Fax: (+49) 3328 4784-30

Microchip Frequency Technology GmbH reserves the right to make changes to the product(s) and/or information contained herein without notice. No liability is assumed as a result of their use or application. No rights under any patent accompany the sale of any such product(s) or information.

Filter characteristic

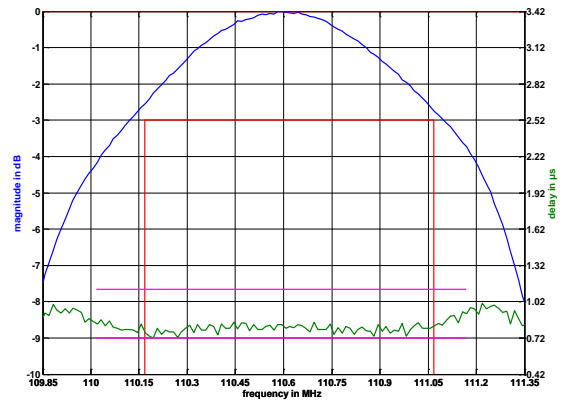
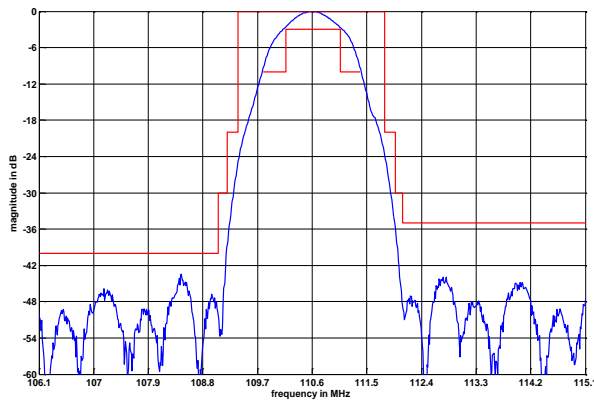

Construction and pin connection

(All dimensions in mm)

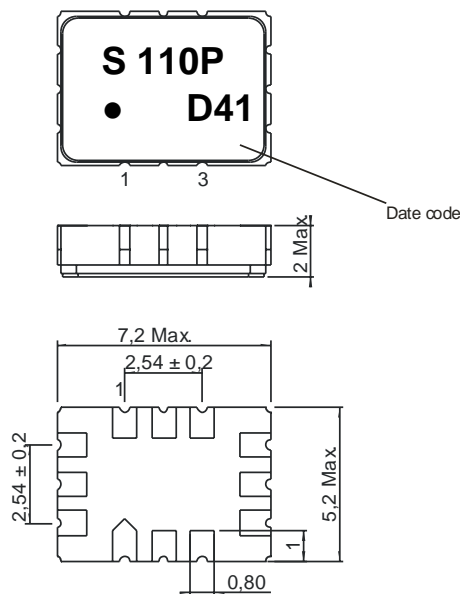

- 1 Ground
- 2 Ground
- 3 Output RF Return
- 4 Output
- 5 Ground
- 6 Ground
- 7 Ground
- 8 Ground
- 9 Input RF Return
- 10 Input
- 11 Ground
- 12 Ground

Date code: Year + week
 D 2013
 E 2014
 F 2015
 ...

50 Ω Test circuit

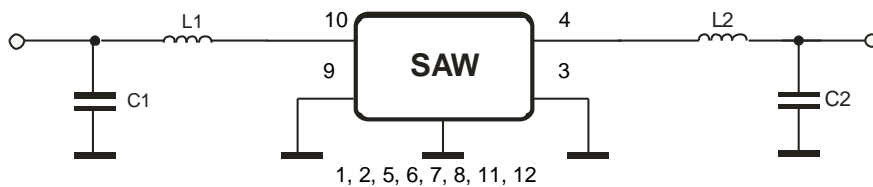

Microchip Frequency Technology GmbH
 Potsdamer Straße 18
 D 14 513 TELTOW / Germany
 Tel: (+49) 3328 4784-0 / Fax: (+49) 3328 4784-30

Microchip Frequency Technology GmbH reserves the right to make changes to the product(s) and/or information contained herein without notice. No liability is assumed as a result of their use or application. No rights under any patent accompany the sale of any such product(s) or information.

Stability characteristics, reliability

After the following tests the filter shall meet the whole specification:

1. Shock: 500g, 1 ms, half sine wave, 3 shocks each plane;
DIN IEC 68 T2 - 27
2. Vibration: 10 Hz to 500 Hz, 0.35 mm or 5 g respectively, 1 octave per min, 10 cycles per plane, 3 planes;
DIN IEC 68 T2 - 6
3. Change of temperature: 55 °C to 125°C / 15 min. each / 100 cycles
DIN IEC 68 part 2 – 14 Test N
4. Resistance to solder heat (reflow): reflow possible: three times max.;
for temperature conditions refer to the attached "Air reflow temperature conditions" on page 4;
5. ESD ANSI/ESD S20.20-1999, class 1A for HBM

This filter is RoHS compliant (2011/65/EU)

Packing

Tape & Reel: IEC 286 – 3, with exception of value for N and minimum bending radius;
tape type II, embossed carrier tape with top cover tape on the upper side;

max. pieces of filters per reel:	3000
reel of empty components at start:	min. 300 mm
reel of empty components at start including leader:	min. 500 mm
trailer:	min. 300 mm

Tape (all dimensions in mm)

- W : 16.00 ± 0.3
- Po : 4.00 ± 0.1
- Do : 1.50 +0.1/-0
- E : 1.75 ± 0.1
- F : 7.50 ± 0.1
- G(min) : 0.60
- P2 : 2.00 ± 0.1
- P1 : 8.00 ± 0.1
- D1(min) : 1.50
- Ao : 5.50 ± 0.1
- Bo : 7.50 ± 0.1
- Ct : 13.5 ± 0.1

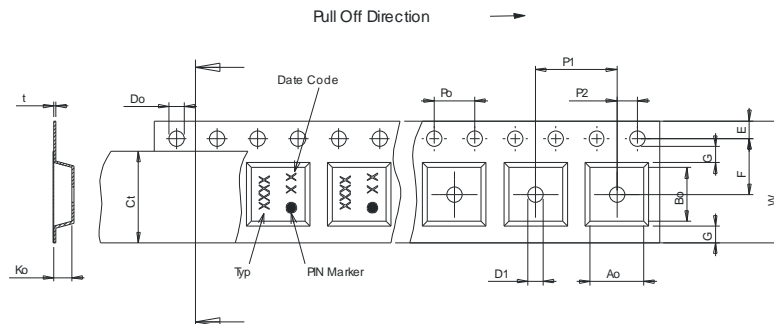

Reel (all dimensions in mm)

- A : 330
- W1 : 16.4 +2/-0
- W2(max) : 22.4
- N(min) : 50
- C : 13.0 +0.5/-0.2

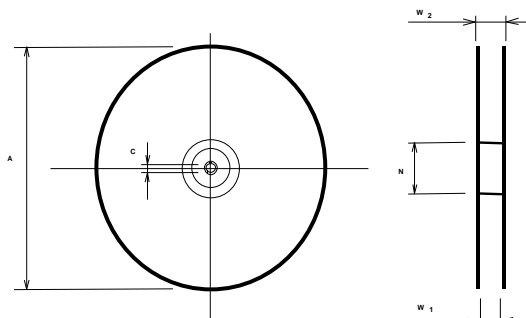

The minimum bending radius is 45 mm.

Microchip Frequency Technology GmbH
Potsdamer Straße 18
D 14 513 TELTOW / Germany
Tel: (+49) 3328 4784-0 / Fax: (+49) 3328 4784-30

Microchip Frequency Technology GmbH reserves the right to make changes to the product(s) and/or information contained herein without notice. No liability is assumed as a result of their use or application. No rights under any patent accompany the sale of any such product(s) or information.

Air reflow temperature conditions

Conditions	Exposure
Average ramp-up rate (30°C to 217°C)	less than 3°C/second
> 100°C	between 300 and 600 seconds
> 150°C	between 240 and 500 seconds
> 217°C	between 30 and 150 seconds
Peak temperature	max. 260°C
Time within 5°C of actual peak temperature	between 10 and 30 seconds
Cool-down rate (Peak to 50°C)	less than 6°C/second
Time from 30°C to Peak temperature	no greater than 300 seconds

Chip-mount air reflow profile

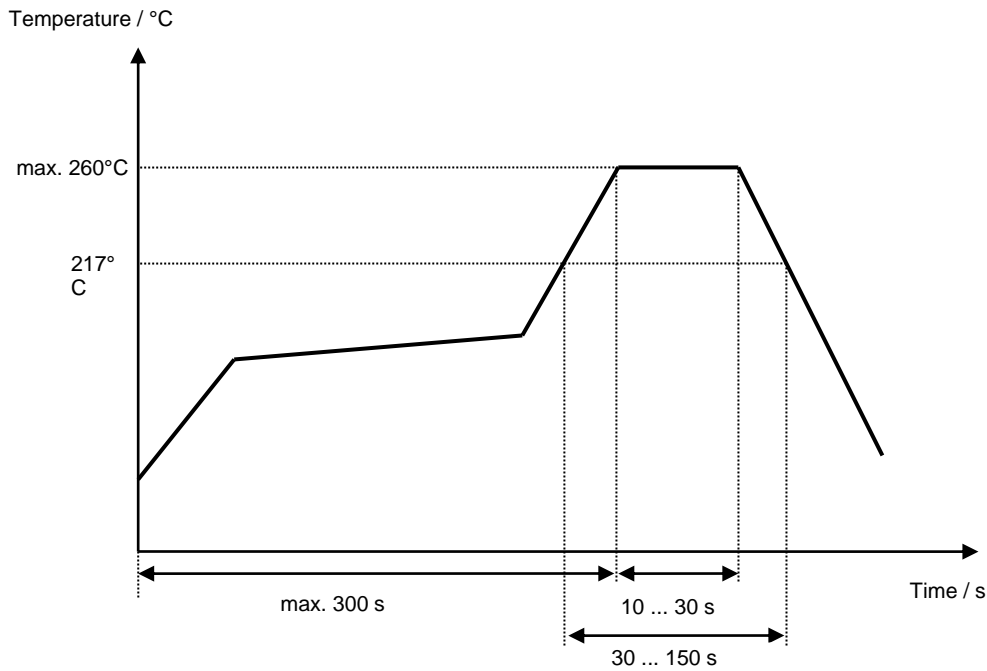

Microchip Frequency Technology GmbH
Potsdamer Straße 18
D 14 513 TELTOW / Germany
Tel: (+49) 3328 4784-0 / Fax: (+49) 3328 4784-30

Microchip Frequency Technology GmbH reserves the right to make changes to the product(s) and/or information contained herein without notice. No liability is assumed as a result of their use or application. No rights under any patent accompany the sale of any such product(s) or information.

Microchip**Filter specification****TFS 110P****5/5****History**

Version	Reason of Changes	Name	Date
2.2	- history added	Braun	12.05.2003
2.3	- change of operating temperature range - add of filter characteristic - stability characteristics and air reflow temperature conditions modified - typical values corrected and added	Pfeiffer	11.10.2006
3.0	- corrected relative attenuation fc + 800 kHz ... fc + 1200 kHz 8.5dB max. 10dB fc - 800 kHz ... fc - 1210 kHz 8dB max. 10dB fc - 1535 kHz ... fc - 10 MHz 42dB min. 40dB to fc + 475 kHz ... fc + 800 kHz 8.5dB max. 10dB fc - 425 kHz ... fc - 800 kHz 8dB max. 10dB fc - 1535 kHz ... fc - 10 MHz 42dB min. 40dB Updated to new format.	TCUK	19.19.2013

Microchip Frequency Technology GmbH
Potsdamer Straße 18
D 14 513 TELTOW / Germany
Tel: (+49) 3328 4784-0 / Fax: (+49) 3328 4784-30

Microchip Frequency Technology GmbH reserves the right to make changes to the product(s) and/or information contained herein without notice. No liability is assumed as a result of their use or application. No rights under any patent accompany the sale of any such product(s) or information.