

Microchip**Filter specification****TFS602****1/5****Measurement condition**

Ambient temperature T_A :	23	°C
Input power level:	0	dBm
Terminating impedance:		
Input:	50	Ω
Output:	50	Ω

Characteristics

Remark:

The maximum attenuation in the pass band is defined as the insertion loss a_e . The nominal frequency f_N is fixed at 602 MHz without any tolerance or limit. The values of absolute attenuation a_{abs} are guaranteed over the whole operating temperature range. The frequency shift of the filter within the operating temperature range OTR3 is included in the production tolerance scheme.

Data	typ. value		tolerance / limit			
Insertion loss within PB (OTR1)	a_e	2.0	dB	max.	3.0	dB
Insertion loss within PB (OTR2)				max.	4.0	dB
Insertion loss within PB (OTR3)				max.	4.5	dB
Nominal frequency	f_N	-			602	MHz
Passband	PB			$f_N \pm$	12	MHz
Absolute attenuation	a_{abs}					
$f_N \pm 80$ MHz ... $f_N \pm 149$ MHz		50	dB	min.	33.5	dB
$f_N + 149$ MHz ... $f_N + 300$ MHz		50	dB	min.	45.0	dB
1 MHz ... 200 MHz		59	dB	min.	50.0	dB
200 MHz ... $f_N - 149$ MHz		64	dB	min.	55.0	dB
Group delay ripple within PB	p-p	11	ns	max.	0.2	μ s
IIP3	*)	-		min.	36	dBm
Input power level		-		max.	10	dBm
Operating temperature range 1	OTR1	-			-10 °C ... +75 °C	
Operating temperature range 2	OTR2	-			-40 °C ... +85 °C	
Operating temperature range 3	OTR3	-			-55 °C ... +95 °C	
Storage temperature range		-			-65 °C ... +125 °C	
Temperature coefficient of frequency	TC_f **)	-76	ppm/K			

*) $f_{in1} = f_C - 14$ MHz; $f_{in2} = f_C - 14.4$ MHz; $P_{in} = 0$ dBm; $f_{measurement1} = f_C - 13.6$ MHz; $f_{measurement2} = f_C - 14.8$ MHz. The centre frequency f_C is the arithmetic mean value of the upper and lower frequencies at the 3 dB filter attenuation level relative to the insertion loss a_e .

**) $\Delta f = TC_f(T - T_A)f_N$

Generated:**Checked / Approved:**

Microchip Frequency Technology GmbH
Potsdamer Straße 18
D 14 513 TELTOW / Germany
Tel: (+49) 3328 4784-0 / Fax: (+49) 3328 4784-30

Microchip Frequency Technology GmbH reserves the right to make changes to the product(s) and/or information contained herein without notice. No liability is assumed as a result of their use or application. No rights under any patent accompany the sale of any such product(s) or information.

Filter characteristic

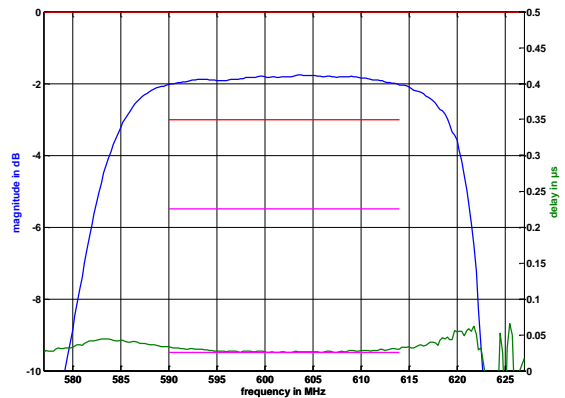
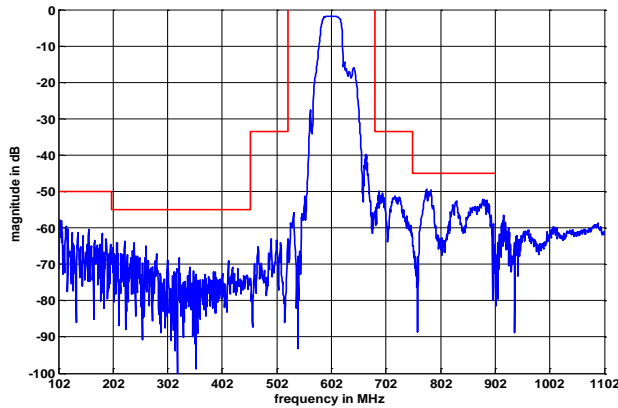

Construction and pin connection

(All dimensions in mm)

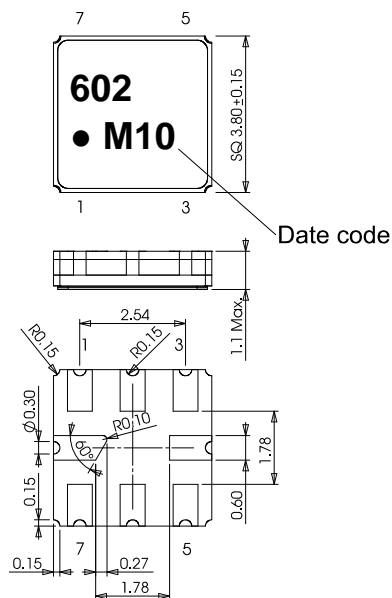

- 1 Ground
- 2 Input
- 3 Ground
- 4 Ground
- 5 Ground
- 6 Output
- 7 Ground
- 8 Ground

Date code: Year + week
 M 2020
 N 2021
 P 2022
 ...

50 Ω Test circuit

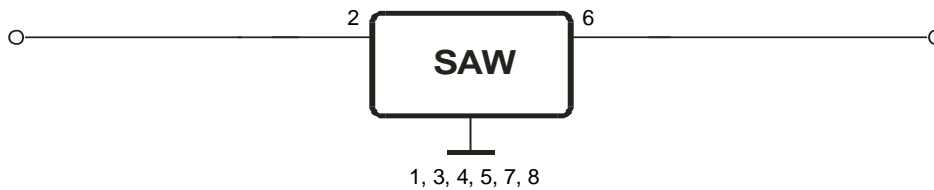

Microchip Frequency Technology GmbH
 Potsdamer Straße 18
 D 14 513 TELTOW / Germany
 Tel: (+49) 3328 4784-0 / Fax: (+49) 3328 4784-30

Microchip Frequency Technology GmbH reserves the right to make changes to the product(s) and/or information contained herein without notice. No liability is assumed as a result of their use or application. No rights under any patent accompany the sale of any such product(s) or information.

Stability characteristics, reliability

After the following tests the filter shall meet the whole specification:

1. Shock: 500 g, 1 ms, half sine wave, 3 shocks each plane;
DIN IEC 60068 T2 - 27
2. Vibration: 10 Hz to 2000 Hz, 0.35 mm or 5 g respectively, 1 octave per min, 10 cycles per plane, 3 planes; DIN IEC 60068 T2 - 6
3. Change of temperature: -55 °C to 125 °C / 15 min. each / 100 cycles
DIN IEC 60068 part 2 – 14 Test N
4. Resistance to solder heat (reflow): reflow possible: three times max.;
for temperature conditions refer to the attached "Air reflow temperature conditions" on page 4;
5. SAW devices are Electrostatic Discharge (ESD) sensitive devices.

This filter is RoHS compliant (2011/65/EU)

Packing

Tape & Reel: IEC 286 – 3, with exception of value for N and minimum bending radius;
tape type II, embossed carrier tape with top cover tape on the upper side;

reel of empty components at start:	min. 300 mm
reel of empty components at start including leader:	min. 500 mm
trailer:	min. 300 mm

Tape (all dimensions in mm)

- W : 12.00 ±0.3
- Po : 4.00 ±0.1
- Do : 1.50 +0.1/-0
- E : 1.75 ±0.1
- F : 5.50 ±0.05
- G(min) : 0.75
- P2 : 2.00 ±0.05
- P1 : 8.00 ±0.1
- D1(min) : 1.50
- Ao : 4.30 ±0.1
- Bo : 4.30 ±0.1
- Ct : 9.2 ±0.1
- Ko : 1.80 ±0.1
- t : 0.30 ±0.05

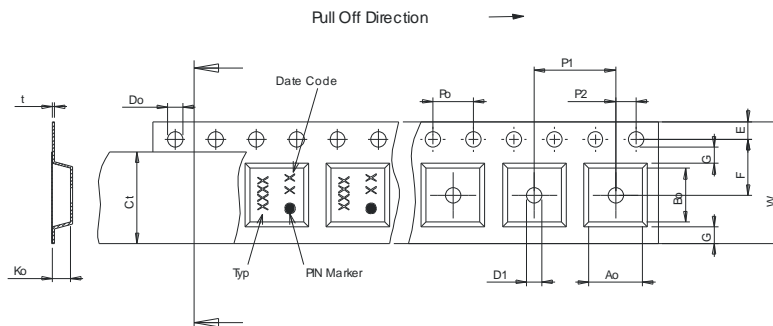

Reel (all dimensions in mm)

- A : 330 or 180
- W1 : 12.4 +2/-0
- W2(max) : 18.40
- N(min) : 50.00
- C : 13.0 +0.5/-0.2

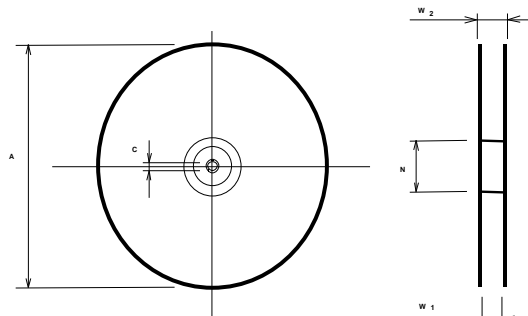

The minimum bending radius is 45 mm.

Microchip Frequency Technology GmbH
Potsdamer Straße 18
D 14 513 TELTOW / Germany
Tel: (+49) 3328 4784-0 / Fax: (+49) 3328 4784-30

Microchip Frequency Technology GmbH reserves the right to make changes to the product(s) and/or information contained herein without notice. No liability is assumed as a result of their use or application. No rights under any patent accompany the sale of any such product(s) or information.

Air reflow temperature conditions

Conditions	Exposure
Average ramp-up rate (30 °C to 217 °C)	less than 3 °C / second
> 100 °C	between 300 and 600 seconds
> 150 °C	between 240 and 500 seconds
> 217 °C	between 30 and 150 seconds
Peak temperature	max. 260 °C
Time within 5 °C of actual peak temperature	between 10 and 30 seconds
Cool-down rate (Peak to 50 °C)	less than 6 °C / second
Time from 30 °C to Peak temperature	no greater than 300 seconds

Chip-mount air reflow profile

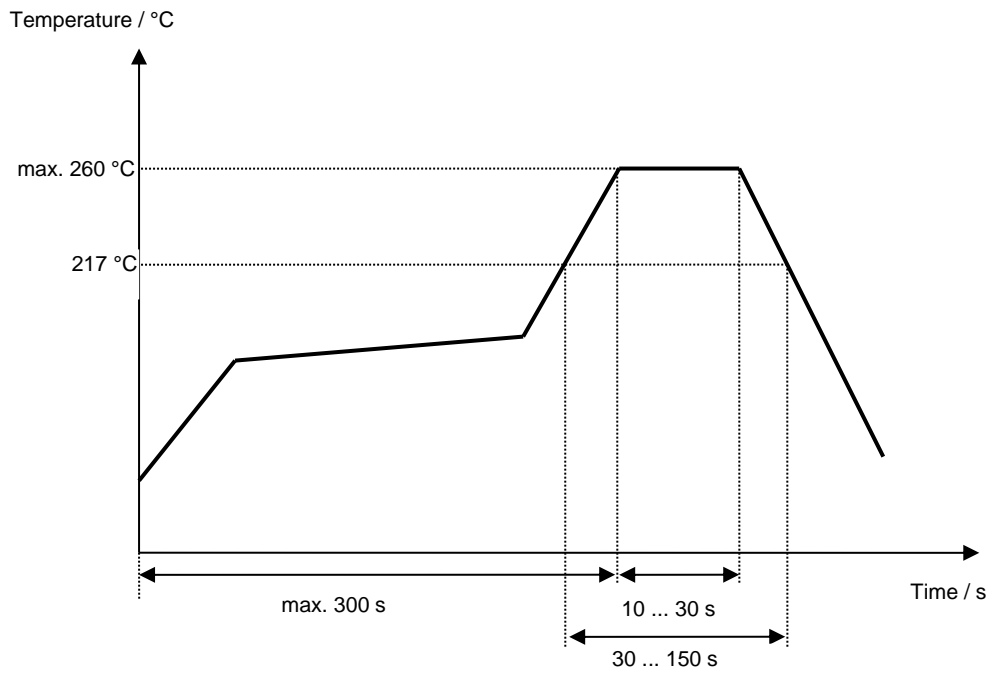

Microchip**Filter specification****TFS602****5/5****History**

Version	Reason of Changes	Name	Date
1.0	Generation of development specification	Springfeldt	14.04.2004
1.1	adjust attenuation and loss to new customer requirements	Noack	26.11.2004
1.2	adjust attenuation and loss to new customer requirements	Martens	29.11.2004
1.3	Change of absolute attenuation	Strehl	20.01.2005
1.4	Change stability characteristics add typical values and filter characteristic generation of filter specification	Strehl	09.05.2005
1.5	Add IIP3 and change stability characteristics	Strehl	19.07.2006
2.0	Add OTR2	S. Channaa	28.06.2011
2.1	Typos corrected	Molke	27.02.2014
3.0	added OTR3 + insertion loss within OTR3 updated construction	P. Jaster	07.02.2020
3.1	updated storage temperature range	P. Jaster	10.02.2020
3.2	corrected typo in pin connection	P. Jaster	02.03.2020

Microchip Frequency Technology GmbH
Potsdamer Straße 18
D 14 513 TELTOW / Germany
Tel: (+49) 3328 4784-0 / Fax: (+49) 3328 4784-30

Microchip Frequency Technology GmbH reserves the right to make changes to the product(s) and/or information contained herein without notice. No liability is assumed as a result of their use or application. No rights under any patent accompany the sale of any such product(s) or information.