

Microchip

Filter specification

TFS 322

1/5

Measurement condition

Ambient temperature (T _a):	23	°C
Input power level:	0	dBm
Terminating impedance: *		
Input:	490 Ω -1.6 pF	
Output:	490 Ω -1.6 pF	
External Coil:	175 nH	

Characteristics

Remark:

The nominal frequency f_N is fixed at 322,5 MHz. The insertion loss a_e is defined as loss value determined at f_N. Reference level for the relative attenuation a_{rel} of the TFS 322 is the insertion loss a_e. The centre frequency f_c is the arithmetic mean value of the upper and lower frequencies at the 3 dB filter attenuation level relative to the insertion loss a_e. All specified data are met within the operating temperature range.

Data		typ. value		tolerance / limit		
Insertion loss (reference level)	a _e	4	dB	max.	6,5	dB
Nominal frequency	f _N	-			322.5	MHz
Centre frequency at T_a	f _c	322.516	MHz	min.	322.471	MHz
				max.	322.585	MHz
Passband		-		f _N	± 70	kHz
Bandwidth	BW					
3 dB		310	kHz	min.	280	kHz
Relative attenuation	a _{rel}					
f _N ± 400 kHz		29	dB	min.	15	dB
f _N ± 400 kHz ... f _N ± 600 kHz		29	dB	min.	27	dB
f _N ± 600 kHz ... f _N ± 13 MHz		42	dB	min.	35	dB
Group delay ripple						
f _N ± 70 kHz		0.8	µs	max.	2	µs
Input power level		-		max.	13	dBm
Operating temperature range	OTR	-			-20 °C ... +70 °C	
Storage temperature range		-			-30 °C ... +85 °C	
Frequency inversion temperature	T _o	25	°C		-	
Temperature coefficient of frequency	TC _f **	-0.032	ppm/K ²		-	

*) The terminating impedances depend on parasitics and q-values of matching elements and the board used, and are to be understood as reference values only. Should there be additional questions do not hesitate to ask for an application note or contact our design team.

***) Δf(Hz) = TC_f(ppm/K²) x (T-T_o)² x f_{T_o}(MHz).

Generated:

Checked / Approved:

Microchip Frequency Technology GmbH
Potsdamer Straße 18
D 14 513 TELTOW / Germany
Tel: (+49) 3328 4784-0 / Fax: (+49) 3328 4784-30

Microchip Frequency Technology GmbH reserves the right to make changes to the product(s) and/or information contained herein without notice. No liability is assumed as a result of their use or application. No rights under any patent accompany the sale of any such product(s) or information.

Stability characteristics, reliability

After the following tests the filter shall meet the whole specification:

1. Shock: 500g, 1 ms, half sine wave, 3 shocks each plane;
DIN IEC 68 T2 - 27
2. Vibration: 10 Hz to 500 Hz, 0.35 mm or 5 g respectively, 1 octave per min, 10 cycles per plane, 3 planes; DIN IEC 68 T2 - 6
3. Change of temperature: -55 °C to 125°C / 15 min. each / 100 cycles
DIN IEC 68 part 2 – 14 Test N
4. Resistance to solder heat (reflow): reflow possible: three times max.;
for temperature conditions, see page 4: "Air reflow temperature conditions"
5. ESD ANSI/ESD S20.20-1999, class 1A for HBM

This filter is RoHS compliant (2011/65/EU)

Packing

Tape & Reel: IEC 286 – 3, with exception of value for N and minimum bending radius;
tape type II, embossed carrier tape with top cover tape on the upper side;

max. pieces of filters per reel:	3000
reel of empty components at start:	min. 300 mm
reel of empty components at start including leader:	min. 500 mm
trailer:	min. 300 mm

Tape (all dimensions in mm)

- W : 12.00
- Po : 4.00
- Do : 1.50
- E : 1.75
- F : 5.50
- G(min) : 0.75
- P2 : 2.00
- P1 : 8.00
- D1(min) : 1.50
- Ao : 5.30
- Bo : 5.30
- Ct : 9.2 ± 0.1

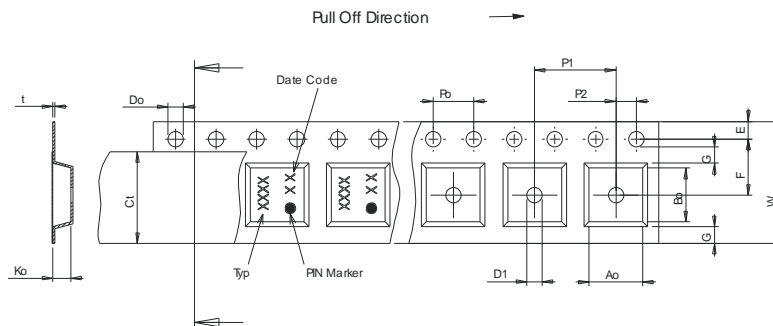

Reel (all dimensions in mm)

- A : 330 or 180
- W1 : 12.4 +2/-0
- W2(max) : 18.4
- N(min) : 50
- C : 13.0

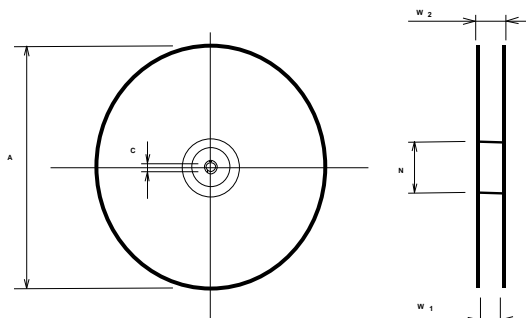

The minimum bending radius is 45 mm.

Microchip Frequency Technology GmbH
Potsdamer Straße 18
D 14 513 TELTOW / Germany
Tel: (+49) 3328 4784-0 / Fax: (+49) 3328 4784-30

Microchip Frequency Technology GmbH reserves the right to make changes to the product(s) and/or information contained herein without notice. No liability is assumed as a result of their use or application. No rights under any patent accompany the sale of any such product(s) or information.

Air reflow temperature conditions

Conditions	Exposure
Average ramp-up rate (30°C to 217°C)	less than 3°C/second
> 100°C	between 300 and 600 seconds
> 150°C	between 240 and 500 seconds
> 217°C	between 30 and 150 seconds
Peak temperature	max. 260°C
Time within 5°C of actual peak temperature	between 10 and 30 seconds
Cool-down rate (Peak to 50°C)	less than 6°C/second
Time from 30°C to Peak temperature	no greater than 300 seconds

Chip-mount air reflow profile

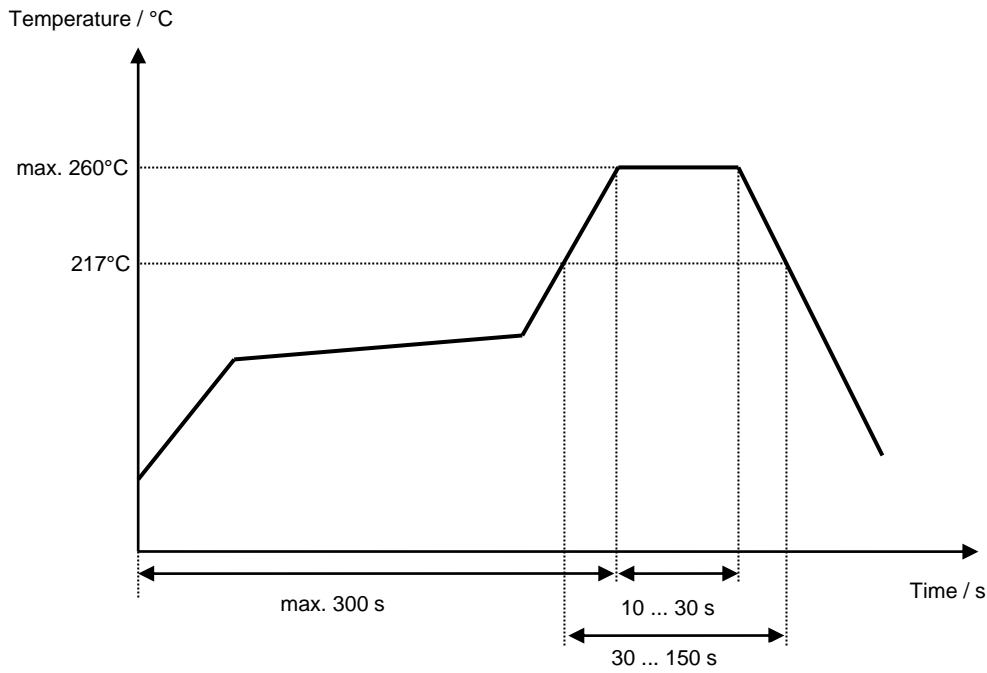

Microchip Frequency Technology GmbH
Potsdamer Straße 18
D 14 513 TELTOW / Germany
Tel: (+49) 3328 4784-0 / Fax: (+49) 3328 4784-30

Microchip Frequency Technology GmbH reserves the right to make changes to the product(s) and/or information contained herein without notice. No liability is assumed as a result of their use or application. No rights under any patent accompany the sale of any such product(s) or information.

Microchip**Filter specification****TFS 322****5/5****History**

Version	Reason of Changes	Name	Date
1.0	Generation of development specification according to customer requirements.	M.Springfeldt	13.04.2004
1.1	Add typical values Replace usable signal bandwidth by passband Correct tape and reel Renew remark of characteristics Fix termination impedances	Dr. Wall	22.06.2004
1.2	Correct stability characteristics Change air reflow temperature conditions Replace characteristics by standard characteristics text	Alawneh	06.03.2006
1.3	Add filter characteristic and generation of filter specification	Strehl	24.08.2006
1.4	Add frequency limits for centre frequency Update footer and header Update tape & reel dimensions	S. Bonnen	07.01.2015

Microchip Frequency Technology GmbH
Potsdamer Straße 18
D 14 513 TELTOW / Germany
Tel: (+49) 3328 4784-0 / Fax: (+49) 3328 4784-30

Microchip Frequency Technology GmbH reserves the right to make changes to the product(s) and/or information contained herein without notice. No liability is assumed as a result of their use or application. No rights under any patent accompany the sale of any such product(s) or information.