

**Microchip**

**Filter specification**

**TFS 254D**

**1/5**

**Measurement condition**

Ambient temperature:	23	°C
Input power level:	0	dBm
Terminating impedance: *		
Input:	108 Ω    -14.3 pF	
Output:	94 Ω    -20 pF	

**Characteristics**

**Remark:**

The reference level for the relative attenuation  $a_{rel}$  of the TFS 254D is the minimum of the pass band attenuation. This value is defined as the insertion loss  $a_e$ . The nominal frequency  $f_N$  is fixed at 254,6 MHz without any tolerance. The values of relative attenuation  $a_{rel}$  are guaranteed for the whole operating temperature range. The frequency shift of the filter in the operating temperature range is included in the production tolerance scheme.

<b>D a t a</b>	<b>typ. value</b>		<b>tolerance / limit</b>						
<b>Insertion loss</b> (reference level)	$a_e$	10	dB	max. 11,0	dB				
<b>Nominal frequency</b>	$f_N$			254,6	MHz				
<b>Passband</b>	PB	30,8	MHz	$f_N \pm$	13,5	MHz			
<b>Pass band ripple</b>	p-p	0,3	dB	max.	1,0	dB			
<b>Amlitude ripple</b> within any 1MHz PB segment		0,2	dB	max.	0,3	dB			
<b>Relative attenuation</b>	$a_{rel}$								
$f_N$	... $f_N \pm$	13,5	MHz	0,3	dB	max. 1	dB		
1	MHz	$f_N -$	244,6	MHz	40	dB	min. 30	dB	
$f_N -$	244,6	MHz	... $f_N -$	82,6	MHz	62	dB	min. 45	dB
$f_N -$	82,6	MHz	... $f_N -$	79,6	MHz	61	dB	min. 55	dB
$f_N -$	79,6	MHz	... $f_N -$	48,7	MHz	51	dB	min. 40	dB
$f_N \pm$	19,0	MHz	... $f_N \pm$	23,5	MHz	7	dB	min. 3	dB
$f_N \pm$	23,5	MHz	... $f_N \pm$	48,7	MHz	6	dB	min. 25	dB
$f_N +$	48,7	MHz	... $f_N +$	62,3	MHz	48	dB	min. 40	dB
$f_N +$	62,3	MHz	... $f_N +$	67,4	MHz	56	dB	min. 50	dB
$f_N +$	67,4	MHz	... $f_N +$	84,4	MHz	59	dB	min. 35	dB
$f_N +$	84,4	MHz	... $f_N +$	500,0	MHz	55	dB	min. 25	dB
<b>Group delay ripple within PB</b>		35	ns	max.	50	ns			
<b>Group delay ripple within any 1MHz PB segment</b>		30	ns	max.	30	ns			
<b>Absolute group delay within PB</b>		440	ns	max.	450	ns			
<b>IIP3</b>	**	47	dBm	min.	36	dBm			
<b>Input power level</b>				max.	20	dBm			
<b>Operating temperature range</b>	OTR			- 35 °C ... + 85 °C					
<b>Storage temperature range</b>				- 40 °C ... + 85 °C					
<b>Temperature coefficient of frequency</b>	$TC_f$ ****	-94	ppm/K		-				

\*) The terminating impedances depend on parasitics and q-values of matching elements and the board used, and are to be understood as reference values only. Should there be additional questions do not hesitate to ask for an application note or contact our design team.

\*\*)  $f_{in1} = 246.6\text{MHz}$ ;  $f_{in2} = 250.6\text{MHz}$ ;  $P_{in} = 0\text{dBm}$ ,  $f_{measurement} = 254.6\text{MHz}$ .

\*\*\*\*)  $\Delta f(\text{Hz}) = TC_f(\text{ppm/K}) \times (T - T_0) \times f_{cat}(\text{MHz})$ .

**Generated:**

**Checked / Approved:**

**Microchip Frequency Technology GmbH**  
**Potsdamer Straße 18**  
**D 14 513 TELTOW / Germany**  
**Tel: (+49) 3328 4784-0 / Fax: (+49) 3328 4784-30**

Microchip Frequency Technology GmbH reserves the right to make changes to the product(s) and/or information contained herein without notice. No liability is assumed as a result of their use or application. No rights under any patent accompany the sale of any such product(s) or information.

**Filter characteristic**

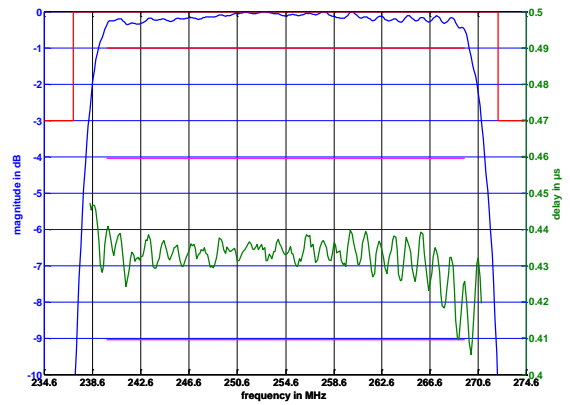
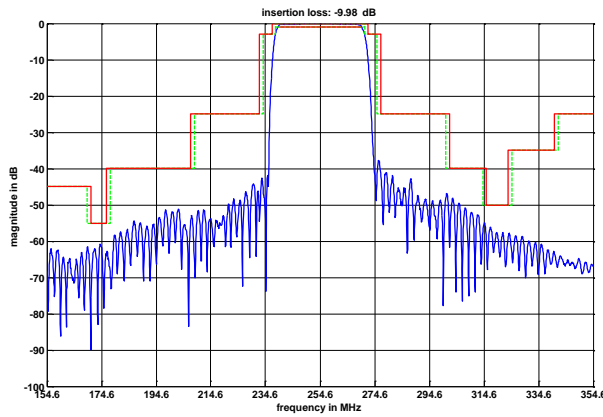

**Construction and pin connection**

(All dimensions in mm)

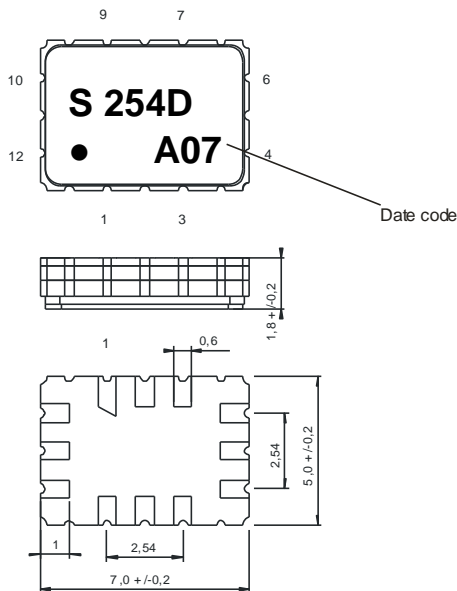

- 1 Ground
- 2 Ground
- 3 Ground
- 4 Output
- 5 Ground
- 6 Output RF Return
- 7 Ground
- 8 Ground
- 9 Ground
- 10 Input
- 11 Ground
- 12 Input RF Return

Date code: Year + week  
 A 2010  
 B 2011  
 C 2012  
 ...

**200 Ω / 150 Ω Test circuit**

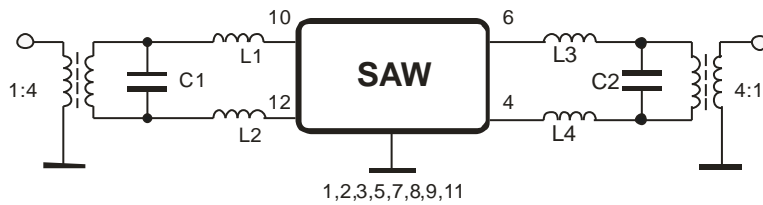

**Microchip Frequency Technology GmbH**  
 Potsdamer Straße 18  
 D 14 513 TELTOW / Germany  
 Tel: (+49) 3328 4784-0 / Fax: (+49) 3328 4784-30

Microchip Frequency Technology GmbH reserves the right to make changes to the product(s) and/or information contained herein without notice. No liability is assumed as a result of their use or application. No rights under any patent accompany the sale of any such product(s) or information.

**Stability characteristics, reliability**

After the following tests the filter shall meet the whole specification:

1. Shock: 500g, 1 ms, half sine wave, 3 shocks each plane;  
DIN IEC 68 T2 - 27
2. Vibration: 10 Hz to 500 Hz, 0,35 mm or 5 g respectively, 1 octave per min, 10 cycles per plan, 3 plans;  
DIN IEC 68 T2 - 6
3. Change of temperature: -55 °C to 125°C / 30 min. each / 10 cycles  
DIN IEC 68 part 2 – 14 Test N
4. Resistance to solder heat (reflow): reflow possible: three times max.;  
for temperature conditions refer to the attached "Air reflow temperature conditions" on page 4;

This filter is RoHS compliant (2002/95/EG, 2005/618/EG)

**Packing**

**Type & Reel:** IEC 286 – 3, with exception of value for N and minimum bending radius;  
tape type II, embossed carrier tape with top cover tape on the upper side;

max. pieces of filters per reel:	3000
reel of empty components at start:	min. 300 mm
reel of empty components at start including leader:	min. 500 mm
trailer:	min. 300 mm

**Tape (all dimensions in mm)**

- W : 16,00 +0,3/-0,1
- Po : 4,00 ± 0,1
- Do : 1,50 +0,1/-0
- E : 1,75 ± 0,1
- F : 7,50 ± 0,1
- G(min) : 0,75
- P2 : 2,00 ± 0,1
- P1 : 8,00 ± 0,1
- D1(min) : 1,50
- Ao : 5,40 ± 0,1
- Bo : 7,60 ± 0,1
- Ct : 13,5 ± 0,1

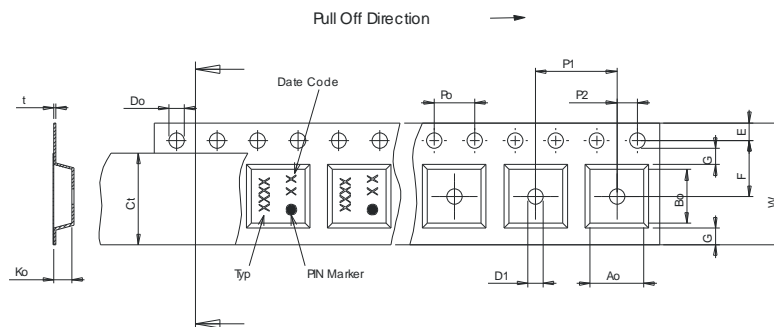

**Reel (all dimensions in mm)**

- A : 330
- W1 : 16,4 +2/-0
- W2(max) : 22,4
- N(min) : 50
- C : 13,0 +0,5/-0,2

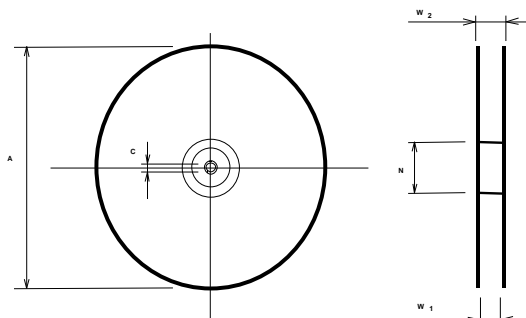

The minimum bending radius is 45 mm.

**Microchip Frequency Technology GmbH**  
**Potsdamer Straße 18**  
**D 14 513 TELTOW / Germany**  
**Tel: (+49) 3328 4784-0 / Fax: (+49) 3328 4784-30**

Microchip Frequency Technology GmbH reserves the right to make changes to the product(s) and/or information contained herein without notice. No liability is assumed as a result of their use or application. No rights under any patent accompany the sale of any such product(s) or information.

**Air reflow temperature conditions**

<b>Conditions</b>	<b>Exposure</b>
Average ramp-up rate (30°C to 217°C)	less than 3°C/second
> 100°C	between 300 and 600 seconds
> 150°C	between 240 and 500 seconds
> 217°C	between 30 and 150 seconds
Peak temperature	max. 260°C
Time within 5°C of actual peak temperature	between 10 and 30 seconds
Cool-down rate (Peak to 50°C)	less than 6°C/second
Time from 30°C to Peak temperature	no greater than 300 seconds

**Chip-mount air reflow profile**

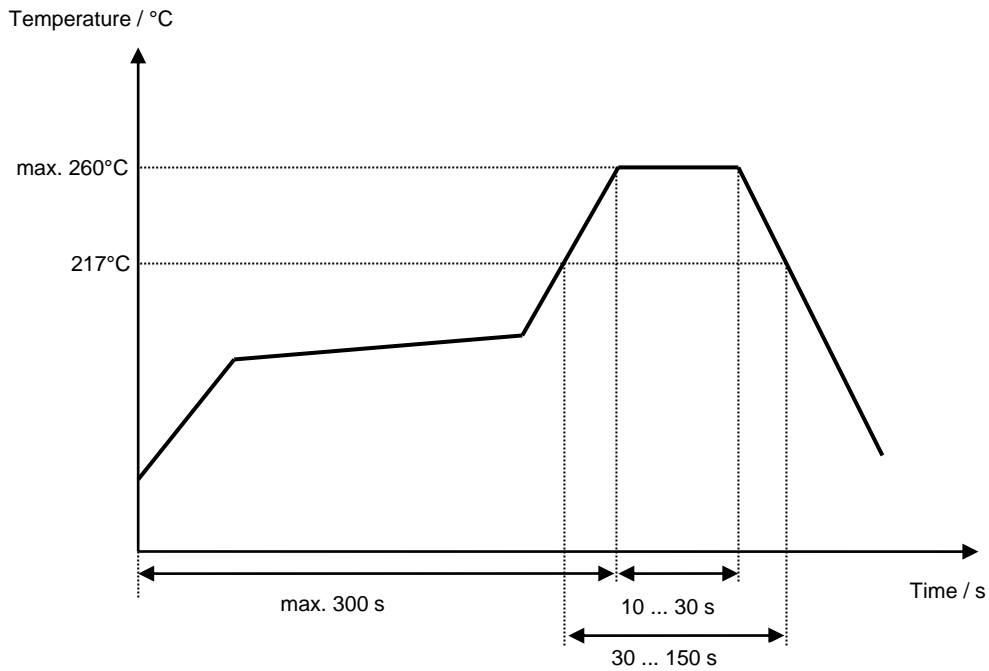

**Microchip Frequency Technology GmbH**  
**Potsdamer Straße 18**  
**D 14 513 TELTOW / Germany**  
**Tel: (+49) 3328 4784-0 / Fax: (+49) 3328 4784-30**

Microchip Frequency Technology GmbH reserves the right to make changes to the product(s) and/or information contained herein without notice. No liability is assumed as a result of their use or application. No rights under any patent accompany the sale of any such product(s) or information.

**Microchip****Filter specification****TFS 254D****5/5****History**

<b>Version</b>	<b>Reason of Changes</b>	<b>Name</b>	<b>Date</b>
1.0	- Generation of development specification	Chilla	16.11.2009
1.1	- Changed insertion loss - Defined absolute group delay (max.)	Chilla	23.11.2009
1.2	- Created Filter specification - Added terminating impedance - Changed relative attenuation - Added typical values - Added filter characteristic - Added filter test circuit	Chilla	08.02.2010
2.0	- Added attenuation at 1MHz.. 10MHz - Added TCF	Chilla	8.02.2010
2.1	- Added IIP3	Chilla	29.09.2011

---

**Microchip Frequency Technology GmbH**  
**Potsdamer Straße 18**  
**D 14 513 TELTOW / Germany**  
**Tel: (+49) 3328 4784-0 / Fax: (+49) 3328 4784-30**

---

Microchip Frequency Technology GmbH reserves the right to make changes to the product(s) and/or information contained herein without notice. No liability is assumed as a result of their use or application. No rights under any patent accompany the sale of any such product(s) or information.