

Microchip**Filter Specification****TFS 280A****1/5****Measurement condition**

Ambient temperature: 23 °C
 Input power level: 0 dBm
 Terminating impedances *)
 for input: 605 Ω // -1.1 pF
 for output: 605 Ω // -1.1 pF

Characteristics**Remark:**

Reference level for the relative attenuation a_{rel} of the TFS 280 A is the minimum of the pass band attenuation a_{min} . The minimum of the pass band attenuation a_{min} is defined as the insertion loss a_e . The centre frequency f_c is the arithmetic mean value of the upper and lower frequencies at the 3 dB filter attenuation level relative to the insertion loss a_e . The nominal frequency f_N is fixed on 280,455 MHz without tolerance. The given values for the relative attenuation a_{rel} and for the group delay ripple have to be reached at the frequencies given below also if the centre frequency f_c is shifted due to the temperature coefficient of frequency TC_f in the operating temperature range and due to a production tolerance for the centre frequency f_c .

D a t a		typ. value		tolerance/limit		
Insertion loss (Reference level)	$a_e = a_{min}$	3,1	dB	max.	5	dB
Nominal frequency	f_N	-			280,455	MHz
Centre frequency	f_c	280,47	MHz		-	
Guaranteed 3 dB signal band width	BW	170	kHz	min.	70	kHz
Relative attenuation $f_N \pm 35$ kHz	a_{rel}	1,2	dB	max.	3	dB
$f_N \pm 200$ kHz		25	dB	min.	10	dB
$f_N \pm 420$ kHz		65	dB	min.	55	dB
Ultimate rejection		60	dB		-	
Group delay ripple $f_N \pm 35$ kHz	GD	1	µs	max.	2	µs
Intermodulation Input IP-3 ($f_N \pm 25$ kHz and $f_N \pm 50$ kHz each of -20 dBm)		-		min.	+15	dBm
Operating temperature range					- 20 °C ... + 85 °C	
Storage temperature range					- 40 °C ... + 85 °C	
Temperature coefficient of frequency**) TC_f		- 0.036	ppm/K ²		-	
Frequency inversion temperature		+ 30	°C		-	

*) The terminating impedances depend on parasitics and q-values of matching elements and the board used, and are to be understood as reference values only. Should there be additional questions do not hesitate to ask for an application note or contact our design team.

***) $\Delta f_c(\text{Hz}) = TC_f(\text{ppm/K}) \times (T - T_o)^2 \times f_{T_o}(\text{MHz})$

Generated: _____**Checked / approved:** _____**Microchip Frequency Technology GmbH****Potsdamer Straße 18****D 14 513 TELTOW / Germany****Tel: (+49) 3328 4784-0 / Fax: (+49) 3328 4784-30**

Microchip Frequency Technology GmbH reserves the right to make changes to the product(s) and/or information contained herein without notice. No liability is assumed as a result of their use or application. No rights under any patent accompany the sale of any such product(s) or information.

Construction, pin configuration and 50 Ω - matching network

(All dimensions in mm)

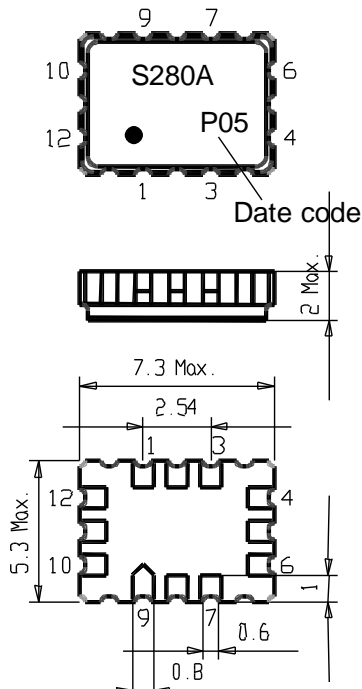

- 1 Output
- 2...6 Package Ground
- 7 Input
- 8...12 Package Ground

Date code: Year+week

- M 2000
- N 2001
- P 2002
- ...

50 Ohm test circuit 1

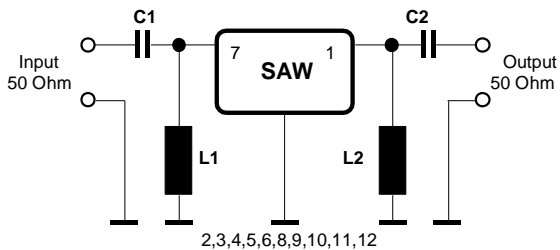

50 Ohm test circuit 2

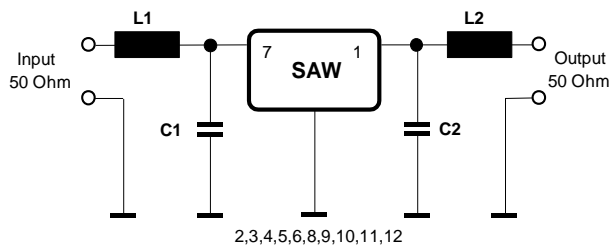

Microchip Frequency Technology GmbH

Potsdamer Straße 18

D 14 513 TELTOW / Germany

Tel: (+49) 3328 4784-0 / Fax: (+49) 3328 4784-30

Microchip Frequency Technology GmbH reserves the right to make changes to the product(s) and/or information contained herein without notice. No liability is assumed as a result of their use or application. No rights under any patent accompany the sale of any such product(s) or information.

Stability Characteristics

After the following tests the filter shall meet the whole specification:

1. Shock: 500g, 18 ms, half sine wave, 3 shocks each plane;
DIN IEC 68 T2 - 27
2. Vibration: 10 Hz to 500 Hz, 1,5 mm or 20g respectively, 1 octave per min, 10 cycles per plan, 3 plans;
DIN IEC 68 T2 - 6
3. Change of temperature: -55 °C to 125°C / 30 min. each / 10 cycles
DIN IEC 68 part 2 – 14 Test N
4. Resistance to solder heat (reflow): reflow possible: twice max.;
for temperature conditions refer to the attached "Air reflow temperature conditions" on page 4;

Packing

Tape & Reel: IEC 286 - 3, with exception of value for N and minimum bending radius;
tape type II, embossed carrier tape with top cover tape on the upper side;

max. pieces of filters per reel: 3000
reel of empty components at start: min 300 mm
reel of empty components at start including leader: min 500 mm
trailer: min 300 mm

Tape (all dimensions in mm)

- W : 16 ± 0,3
- Po : 4 ± 0,1
- Do : 1,5 + 0,1
- E : 1,75 ± 0,1
- F : 7,5 ± 0,1
- G (min) : 0,6
- P2 : 2 ± 0,1
- P1 : 8 ± 0,1
- D1(min) : 1,5
- Ao : 5,5 ± 0,1
- Bo : 7,5 ± 0,1
- CT : 13,5 ± 0,1

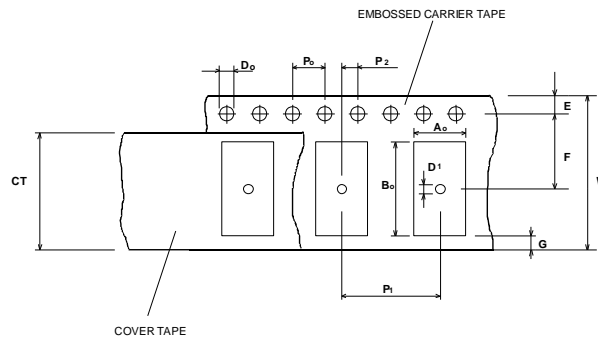

Reel (all dimensions in mm):

- A : 330
- W1 : 16,4 +2
- W2 (max) : 22,4
- N (min) : 50
- C : 13 +0,5 / -0,2

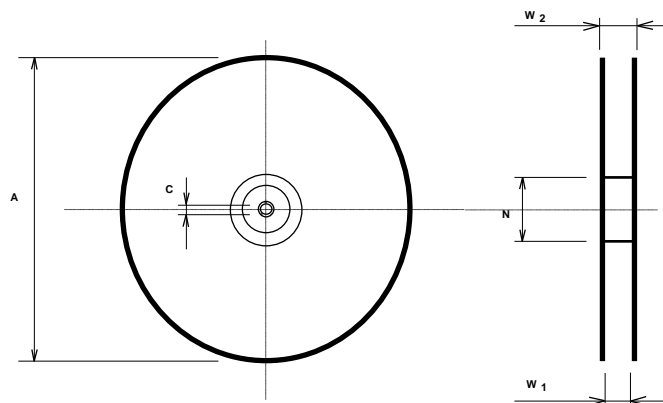

The minimum bending radius is 45 mm. The mounting surface of the filters faces the bottom side of the embossed carrier tape. Markings on the filters can be read if the upper side of the carrier tape is regarded with the sprocket holes on its right.

Microchip Frequency Technology GmbH

Potsdamer Straße 18

D 14 513 TELTOW / Germany

Tel: (+49) 3328 4784-0 / Fax: (+49) 3328 4784-30

Microchip Frequency Technology GmbH reserves the right to make changes to the product(s) and/or information contained herein without notice. No liability is assumed as a result of their use or application. No rights under any patent accompany the sale of any such product(s) or information.

Air reflow temperature conditions

1st and 2nd air reflow profile

Name:	pre-heating periods	main-heating periods	peak temperature
Temperature:	150 °C - 170 °C	over 200 °C	255 °C ± 5 °C
Time:	60 sec. - 90 sec.	20 sec. - 25 sec.	

Chip-mount air reflow profile

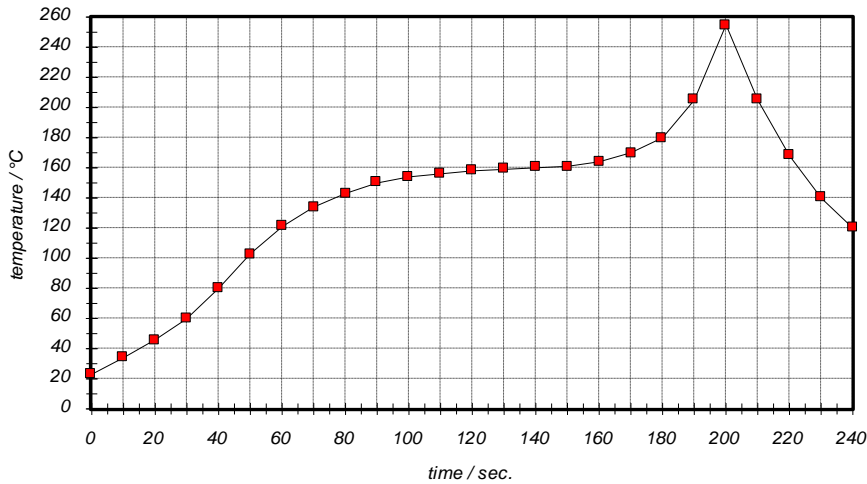

Table for temperature vs. time during the air reflow process

Tolerance of temperatures: ± 5 °C

<u>time / sec.</u>	<u>temperature / °C</u>	<u>time / sec.</u>	<u>temperature / °C</u>
0	23	140	160
10	34	150	161
20	46	160	164
30	60	170	170
40	80	180	180
50	103	190	205
60	121	195	230
70	134	200	255
80	143	205	230
90	150	210	205
100	154	215	180
110	156	220	165
120	158	230	140
130	159	240	120

Microchip Frequency Technology GmbH
Potsdamer Straße 18
D 14 513 TELTOW / Germany
Tel: (+49) 3328 4784-0 / Fax: (+49) 3328 4784-30

Microchip Frequency Technology GmbH reserves the right to make changes to the product(s) and/or information contained herein without notice. No liability is assumed as a result of their use or application. No rights under any patent accompany the sale of any such product(s) or information.

Microchip**Filter Specification****TFS 280A****5/5**

History

Version	Reason of Changes	Name	Date
1.4	Add history. Change date code from monthly to weekly system. Change stability characteristic. Change packing information. Add typical data. Comment terminating impedances.	Dr. Wall	25.01.2002

Microchip Frequency Technology GmbH
Potsdamer Straße 18
D 14 513 TELTOW / Germany
Tel: (+49) 3328 4784-0 / Fax: (+49) 3328 4784-30

Microchip Frequency Technology GmbH reserves the right to make changes to the product(s) and/or information contained herein without notice. No liability is assumed as a result of their use or application. No rights under any patent accompany the sale of any such product(s) or information.