

Microchip	Filter specification	TFS700A	1/5
------------------	-----------------------------	----------------	------------

Measurement condition

Ambient temperature T_A : 23 °C
 Input power level: 0 dBm

Terminating impedance:

Source: 50 Ω
 Load: 50 Ω

 Input: 147.7 Ω || -1.6 pF
 Output: 147.7 Ω || -1.6 pF

Characteristics

Remark:

The reference level for the relative attenuation a_{rel} of the TFS700A is the minimum of the passband attenuation a_{min} . The minimum of the passband attenuation a_{min} is defined as the insertion loss a_e . The centre frequency f_C is the arithmetic mean value of the upper and lower frequencies at the 3 dB filter attenuation level relative to the insertion loss a_e . The nominal frequency f_N is fixed at 700 MHz without any tolerance. The given values for both the relative attenuation a_{rel} and the group delay ripple have to be achieved at the frequencies given below even if the centre frequency f_C is shifted due to the temperature coefficient of frequency TC_f in the operating temperature range and due to a production tolerance for the centre frequency f_C .

D a t a		typ. value		tolerance / limit		
Insertion loss	a_e	2	dB	max.	6	dB
Nominal frequency	f_N	-			700	MHz
Centre frequency	f_C	700	MHz		-	
Passband	PB	-		$f_N \pm$	37.5	kHz
Passband ripple	p-p	0.3	dB	max.	2	dB
Relative attenuation	a_{rel}					
$f_N \pm 1.4$ MHz ... $f_N \pm 5$ MHz		17	dB	min.	6	dB
$f_N \pm 5$ MHz ... $f_N \pm 20$ MHz		28	dB	min.	12	dB
$f_N + 20$ MHz ... $f_N + 180$ MHz		36	dB	min.	30	dB
$f_N - 20$ MHz ... $f_N - 590$ MHz		40	dB	min.	30	dB
Group delay ripple within PB		20	ns	max.	100	ns
Input power level		-		max.	18	dBm
Operating temperature range	OTR	-			-40 °C ... +91 °C	
Storage temperature range		-			-55 °C ... +125 °C	
Frequency inversion temperature	T_0	0	°C		-	
Temperature coefficient of frequency	TC_f *)	-0.040	ppm/K ²		-	

*) $\Delta f = TC_f(T - T_0)^2 f_N$

Generated: _____

Checked / Approved: _____

Microchip Frequency Technology GmbH
Potsdamer Straße 18
D 14 513 TELTOW / Germany
Tel: (+49) 3328 4784-0 / Fax: (+49) 3328 4784-30

Microchip Frequency Technology GmbH reserves the right to make changes to the product(s) and/or information contained herein without notice. No liability is assumed as a result of their use or application. No rights under any patent accompany the sale of any such product(s) or information.

Filter characteristic

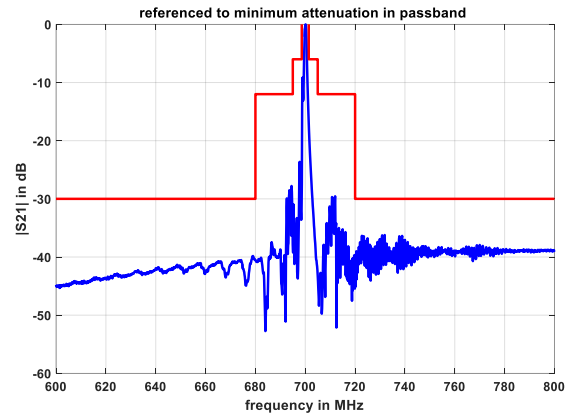
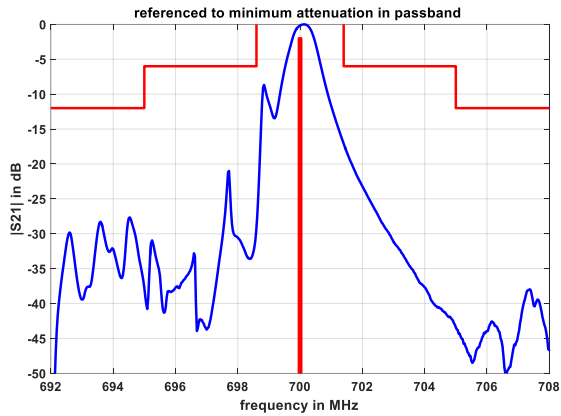

Construction and pin connection

(All dimensions in mm)

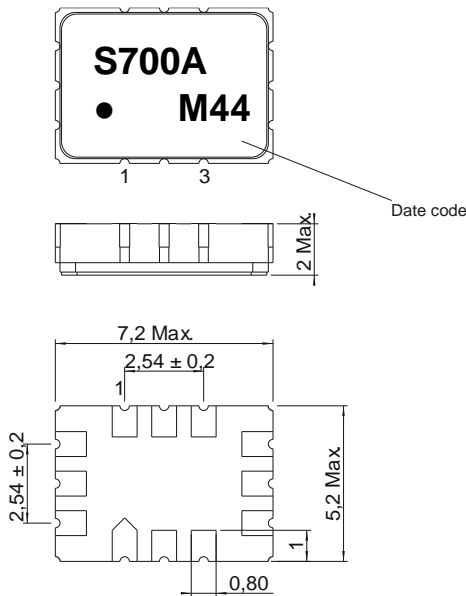

1	Input
2	Ground
3	Ground
4	Ground
5	Ground
6	Ground
7	Output
8	Ground
9	Ground
10	Ground
11	Ground
12	Ground

Date code: Year + week
 M 2020
 N 2021
 P 2022
 ...

50 Ω Test circuit

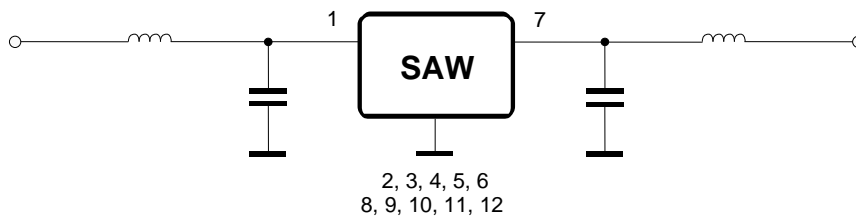

Microchip Frequency Technology GmbH
 Potsdamer Straße 18
 D 14 513 TELTOW / Germany
 Tel: (+49) 3328 4784-0 / Fax: (+49) 3328 4784-30

Microchip Frequency Technology GmbH reserves the right to make changes to the product(s) and/or information contained herein without notice. No liability is assumed as a result of their use or application. No rights under any patent accompany the sale of any such product(s) or information.

Stability characteristics, reliability

After the following tests the filter shall meet the whole specification:

1. Shock: 500g, 1 ms, half sine wave, 3 shocks each plane;
DIN IEC 68 T2 - 27
2. Vibration: 10 Hz to 2000 Hz, 0.35 mm or 5 g respectively, 1 octave per min, 10 cycles per plane, 3 planes; DIN IEC 68 T2 - 6
3. Change of temperature: -55 °C to 125°C / 15 min. each / 100 cycles
DIN IEC 68 part 2 – 14 Test N
4. Resistance to solder heat (reflow): reflow possible: three times max.;
for temperature conditions, see page 4: "Air reflow temperature conditions"

5. SAW devices are Electrostatic Discharge (ESD) sensitive devices.

ESD SIMULATION MODEL	CLASSIFICATION LEVEL	CRITERIA
Human Body Model (HBM) acc. to ANSI/ESDA/JEDEC JS-001-2014	Class 1A	1 positive + 1 negative pulse 125 ... 250 Volts

This filter is RoHS compliant (2011/65/EU+2015/863/EU)

Packing

Tape & Reel: IEC 286 – 3, with exception of value for N and minimum bending radius;
tape type II, embossed carrier tape with top cover tape on the upper side;

reel of empty components at start: min. 300 mm
 reel of empty components at start including leader: min. 500 mm
 trailer: min. 300 mm

Tape (all dimensions in mm)

- W : 16.00 +0.3/-0.1
- Po : 4.00 ±0.1
- Do : 1.50 +0.1/-0
- E : 1.75 ±0.1
- F : 7.50 ±0.1
- G(min) : 0.75
- P2 : 2.00 ±0.1
- P1 : 8.00 ±0.1
- D1(min) : 1.50
- Ao : 5.40 ±0.1
- Bo : 7.60 ±0.1
- Ct : 13.30 ±0.1
- Ko : 2.00 ±0.1
- t : 0.30 ±0.05

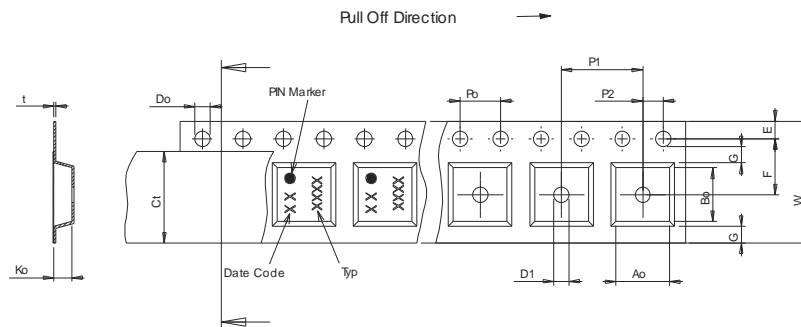

Reel (all dimensions in mm)

- A : 330 or 180
- W1 : 16.4 +2/-0
- W2(max) : 22.40
- N(min) : 50.00
- C : 13.0 +0.5/-0.2

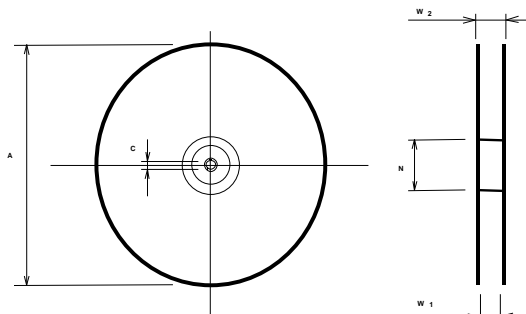

The minimum bending radius is 45 mm.

Microchip Frequency Technology GmbH
Potsdamer Straße 18
D 14 513 TELTOW / Germany
Tel: (+49) 3328 4784-0 / Fax: (+49) 3328 4784-30

Microchip Frequency Technology GmbH reserves the right to make changes to the product(s) and/or information contained herein without notice. No liability is assumed as a result of their use or application. No rights under any patent accompany the sale of any such product(s) or information.

Air reflow temperature conditions

Conditions	Exposure
Average ramp-up rate (30 °C to 217 °C)	less than 3 °C / second
> 100 °C	between 300 and 600 seconds
> 150 °C	between 240 and 500 seconds
> 217 °C	between 30 and 150 seconds
Peak temperature	max. 260 °C
Time within 5 °C of actual peak temperature	between 10 and 30 seconds
Cool-down rate (Peak to 50 °C)	less than 6 °C / second
Time from 30 °C to Peak temperature	no greater than 300 seconds

Chip-mount air reflow profile

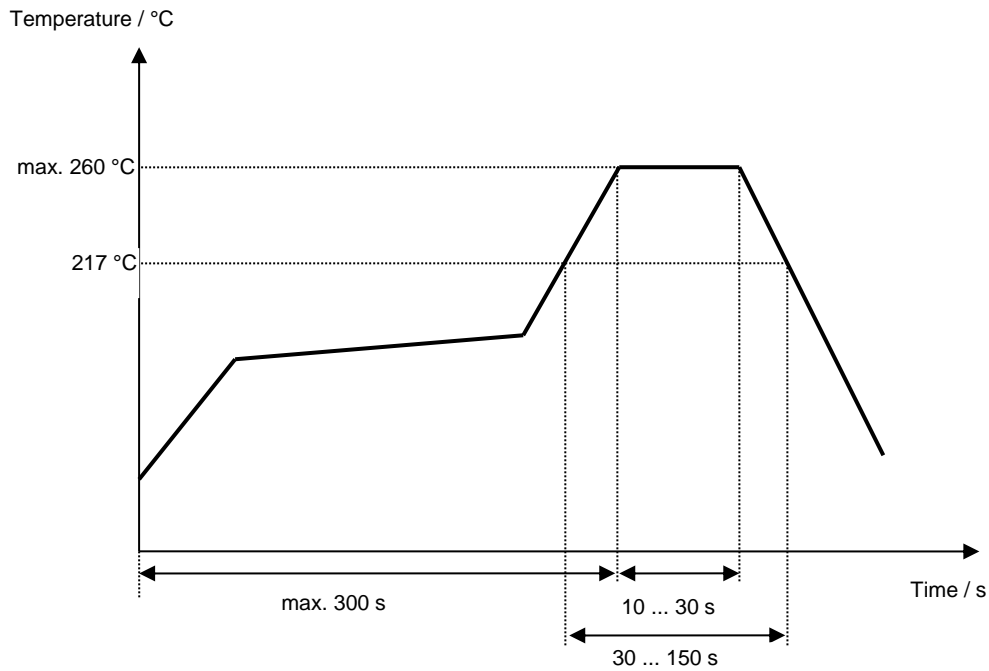

Microchip**Filter specification****TFS700A****5/5**

History

Version	Reason of Changes	Name	Date
1.0	- Generation of development specification	Bonnen	17.12.2019
2.0	- Corrected typo in data section	Bonnen	18.12.2019
3.0	- Change of pin connection	Molke	21.08.2020
3.1	- Update of theoretical matching circuits - Change from development spec to filter spec - Typical values added - Filter characteristic added	Molke	27.10.2020

Microchip Frequency Technology GmbH
Potsdamer Straße 18
D 14 513 TELTOW / Germany
Tel: (+49) 3328 4784-0 / Fax: (+49) 3328 4784-30

Microchip Frequency Technology GmbH reserves the right to make changes to the product(s) and/or information contained herein without notice. No liability is assumed as a result of their use or application. No rights under any patent accompany the sale of any such product(s) or information.