

Microchip**Filter specification****TFS 340****1/5****Measurement condition**

Ambient temperature:	23	°C
Input power level:	0	dBm
Input:	50Ω	
Output:	50Ω	
Source:	162Ω -0.5pF	
Load:	162Ω -0.5pF	

Characteristics**Remark:**

Reference level for the relative attenuation a_{rel} of the TFS340 is the minimum of the pass band attenuation a_{min} . The minimum of the pass band attenuation a_{min} is defined as the insertion loss a_e . The centre frequency f_c is the arithmetic mean value of the upper and lower frequencies at the 3dB filter attenuation level relative to the insertion loss a_e . The nominal frequency f_N is fixed at 340MHz without tolerance. The given values for the relative attenuation a_{rel} and for the group delay ripple have to be reached at the frequencies given below even if the centre frequency f_c is shifted due to the temperature coefficient of frequency TC_f in the operating temperature range and due to a production tolerance for the centre frequency f_c .

D a t a		typ. value	tolerance / limit
Insertion loss (Reference level)	$a_e = a_{min}$	2.6 dB	max. 3 dB
Nominal frequency	f_N	-	340 MHz
Centre frequency	f_c	340.0 MHz	-
Pass band ripple $f_N \pm 10$ MHz		1.4 dB	max. 3 dB **)
Relative attenuation	a_{rel}		
$f_N - 80.0$ MHz ... $f_N - 100.0$ MHz		59 dB	min. 50 dB
$f_N - 35.0$ MHz ... $f_N - 55.0$ MHz		62 dB	min. 30 dB
$f_N + 25.0$ MHz ... $f_N + 57.5$ MHz		23 dB	min. 20 dB
$f_N + 57.5$ MHz ... $f_N + 82.5$ MHz		64 dB	min. 40 dB
$f_N + 127.5$ MHz ... $f_N + 152.5$ MHz		67 dB	min. 50 dB
Intermodulation	IP_3	-	min. 20 dBm ***)
Input power level		-	max. 10 dBm
Permissible DC voltage	V_{DC}	-	max. 12 V
Operating temperature range		-	- 25 °C ... + 75 °C
Temperature coefficient of frequency Tcf		-65 ppm/K	-
Storage temperature range		-	- 40 °C ... + 85 °C

*) The terminating impedances depend on parasitics and q-values of matching elements and the board used, and are to be understood as reference values only. Should there be additional questions, do not hesitate to ask for an application note or contact our design team.

**) -3dB over $f_N \pm 10$ MHz at ambient temperature (23°C).

***) modulation signals: $f_N + 1$ MHz and $f_N + 2$ MHz, each of 10dBm

Generated:**Checked / Approved:**

Microchip Frequency Technology GmbH
Potsdamer Straße 18
D 14 513 TELTOW / Germany
Tel: (+49) 3328 4784-0 / Fax: (+49) 3328 4784-30

Microchip Frequency Technology GmbH reserves the right to make changes to the product(s) and/or information contained herein without notice. No liability is assumed as a result of their use or application. No rights under any patent accompany the sale of any such product(s) or information.

Filter characteristic

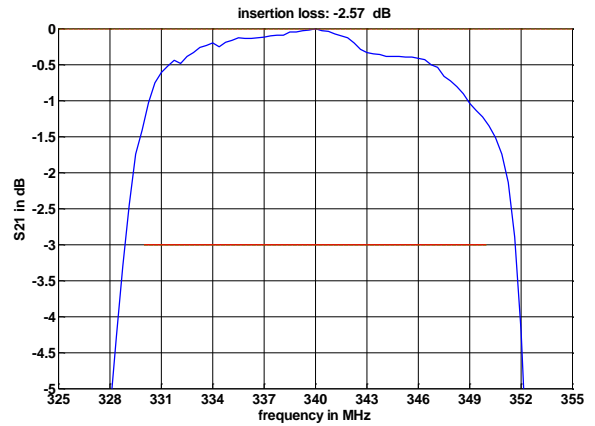
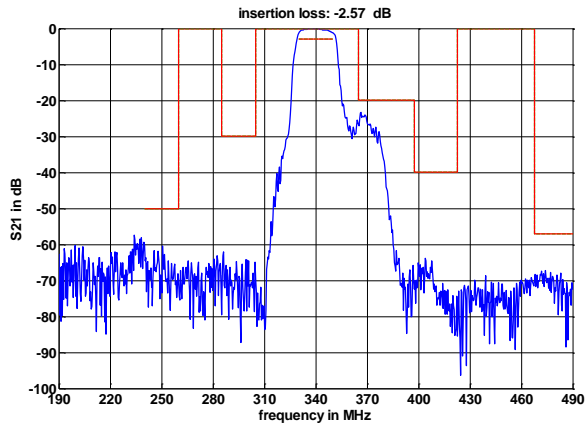

Construction and pin connection

(All dimensions in mm)

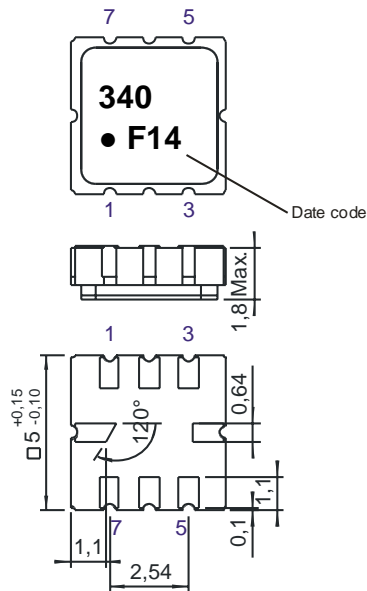

- 1 Input
- 2 Ground
- 3 Ground
- 4 Ground
- 5 Output
- 6 Ground
- 7 Ground
- 8 Ground

Date code: Year + week
 F 2015
 G 2016
 H 2017
 ...

50 Ω Test circuit

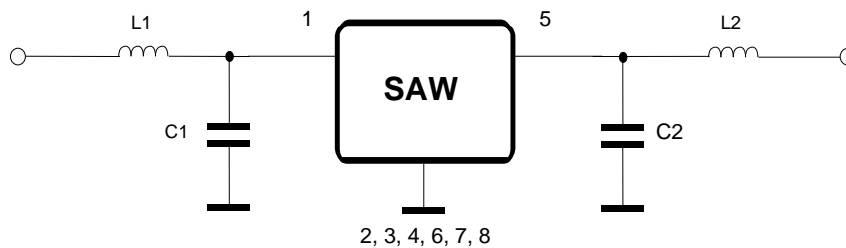

Microchip Frequency Technology GmbH
 Potsdamer Straße 18
 D 14 513 TELTOW / Germany
 Tel: (+49) 3328 4784-0 / Fax: (+49) 3328 4784-30

Microchip Frequency Technology GmbH reserves the right to make changes to the product(s) and/or information contained herein without notice. No liability is assumed as a result of their use or application. No rights under any patent accompany the sale of any such product(s) or information.

Stability characteristics, reliability

After the following tests the filter shall meet the whole specification:

1. Shock: 500g, 1ms, half sine wave, 3 shocks each plane;
DIN IEC 68 T2 - 27
2. Vibration: 10Hz to 500Hz, 0.35 mm or 5g respectively, 1 octave per min, 10 cycles per plane, 3 planes;
DIN IEC 68 T2 - 6
3. Change of temperature: -55 °C to 125°C / 15 min. each / 100 cycles
DIN IEC 68 part 2 – 14 Test N
4. Resistance to solder heat (reflow): reflow possible: three times max.;
for temperature conditions refer to the attached "Air reflow temperature conditions" on page 4;
5. ESD ANSI/ESD S20.20-1999, class 0 for HBM

This filter is RoHS compliant (2011/65/EU)

Packing

Tape & Reel: IEC 286 – 3, with exception of value for N and minimum bending radius;
tape type II, embossed carrier tape with top cover tape on the upper side;

max. pieces of filters per reel: 3000
 reel of empty components at start: min. 300 mm
 reel of empty components at start including leader: min. 500 mm
 trailer: min. 300 mm

Tape (all dimensions in mm)

- W : 12.00
- Po : 4.00
- Do : 1.50
- E : 1.75
- F : 5.50
- G(min) : 0.75
- P2 : 2.00
- P1 : 8.00
- D1(min) : 1.50
- Ao : 5.30
- Bo : 5.30
- Ct : 9.2 ± 0.1

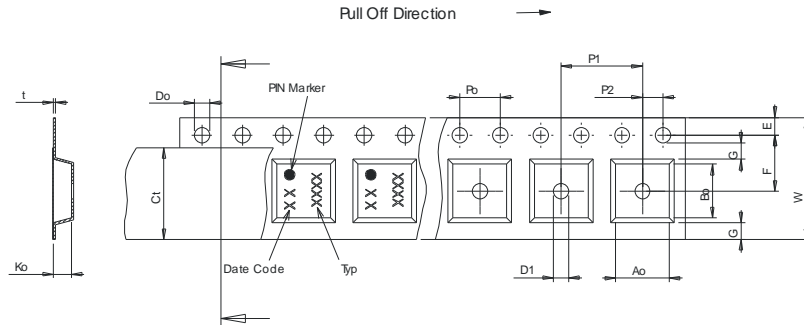

Reel (all dimensions in mm)

- A : 330
- W1 : 12.4 +2/-0
- W2(max) : 18.4
- N(min) : 50
- C : 13.0

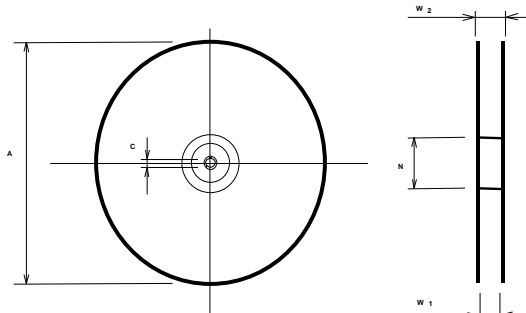

The minimum bending radius is 45 mm.

Microchip Frequency Technology GmbH
Potsdamer Straße 18
D 14 513 TELTOW / Germany
Tel: (+49) 3328 4784-0 / Fax: (+49) 3328 4784-30

Microchip Frequency Technology GmbH reserves the right to make changes to the product(s) and/or information contained herein without notice. No liability is assumed as a result of their use or application. No rights under any patent accompany the sale of any such product(s) or information.

Air reflow temperature conditions

Conditions	Exposure
Average ramp-up rate (30°C to 217°C)	less than 3°C/second
> 100°C	between 300 and 600 seconds
> 150°C	between 240 and 500 seconds
> 217°C	between 30 and 150 seconds
Peak temperature	max. 260°C
Time within 5°C of actual peak temperature	between 10 and 30 seconds
Cool-down rate (Peak to 50°C)	less than 6°C/second
Time from 30°C to Peak temperature	no greater than 300 seconds

Chip-mount air reflow profile

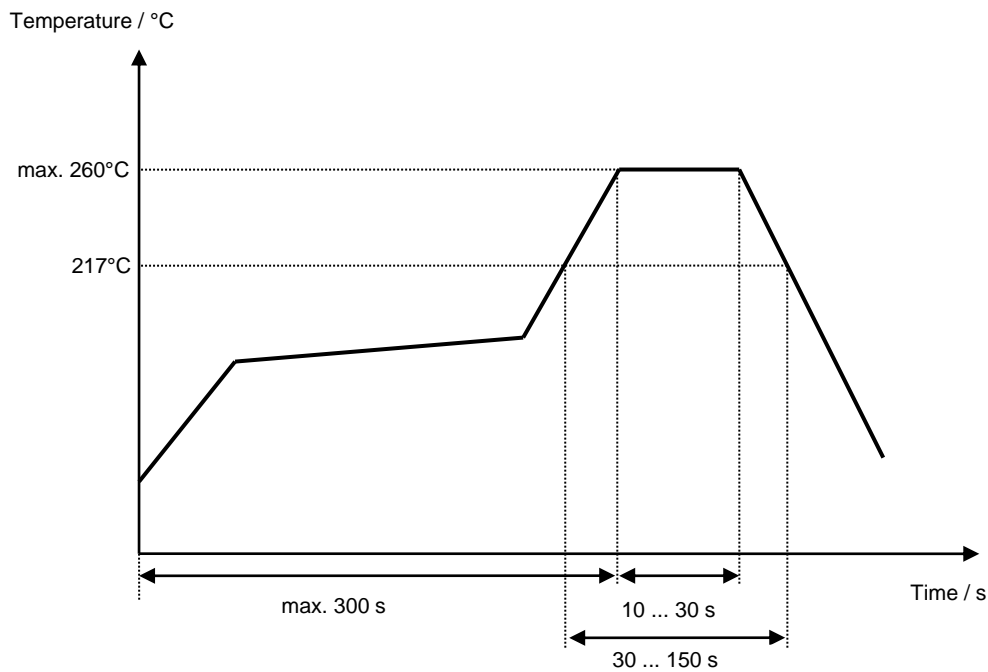

Microchip Frequency Technology GmbH
Potsdamer Straße 18
D 14 513 TELTOW / Germany
Tel: (+49) 3328 4784-0 / Fax: (+49) 3328 4784-30

Microchip Frequency Technology GmbH reserves the right to make changes to the product(s) and/or information contained herein without notice. No liability is assumed as a result of their use or application. No rights under any patent accompany the sale of any such product(s) or information.

Microchip**Filter specification****TFS 340****5/5**

History

Version	Reason of Changes	Name	Date
1.0	- generate according customer requirement specification	Dr. Sabah	02.12.2002
1.1	- filter specification, add of all typical values and terminating impedance	Dr. Sabah	11.02.2003
1.2	- updating specification format and adding typical plots	S.Springfeldt	19.12.2013
1.3	- updating typical values and plots after optimising filter performance	S.Springfeldt	02.04.2015

Microchip Frequency Technology GmbH
Potsdamer Straße 18
D 14 513 TELTOW / Germany
Tel: (+49) 3328 4784-0 / Fax: (+49) 3328 4784-30

Microchip Frequency Technology GmbH reserves the right to make changes to the product(s) and/or information contained herein without notice. No liability is assumed as a result of their use or application. No rights under any patent accompany the sale of any such product(s) or information.