

## FEATURES

- **Low Quiescent Current:**  
     **20 $\mu$ A in Active Mode**  
     **<1 $\mu$ A in Shutdown Mode**
- **Operates with  $V_{IN}$  as Low as 1V**
- Low  $V_{CESAT}$  Switch: 250mV at 300mA
- Uses Small Surface Mount Components
- High Output Voltage: Up to  $-34V$
- Tiny 5-Lead SOT-23 Package

## APPLICATIONS

- LCD Bias
- Handheld Computers
- Battery Backup
- Digital Cameras

## DESCRIPTION

The LT<sup>®</sup>1617/LT1617-1 are micropower inverting DC/DC converters in a 5-lead SOT-23 package. The LT1617 is designed for higher power systems with a 350mA current limit and an input voltage range of 1.2V to 15V, whereas the LT1617-1 is intended for lower power and single-cell applications with a 100mA current limit and an extended input voltage range of 1V to 15V. Otherwise, the two devices are functionally equivalent. Both devices feature a quiescent current of only 20 $\mu$ A at no load, which further reduces to 0.5 $\mu$ A in shutdown. A current limited, fixed off-time control scheme conserves operating current, resulting in high efficiency over a broad range of load current. The 36V switch allows high voltage outputs up to  $-34V$  to be easily generated without the use of costly transformers. The LT1617's low off-time of 400ns permits the use of tiny, low profile inductors and capacitors to minimize footprint and cost in space-conscious portable applications.

LT, LTC and LT are registered trademarks of Linear Technology Corporation.

## TYPICAL APPLICATION

1-Cell Li-Ion to  $-15V$  Inverting Converter

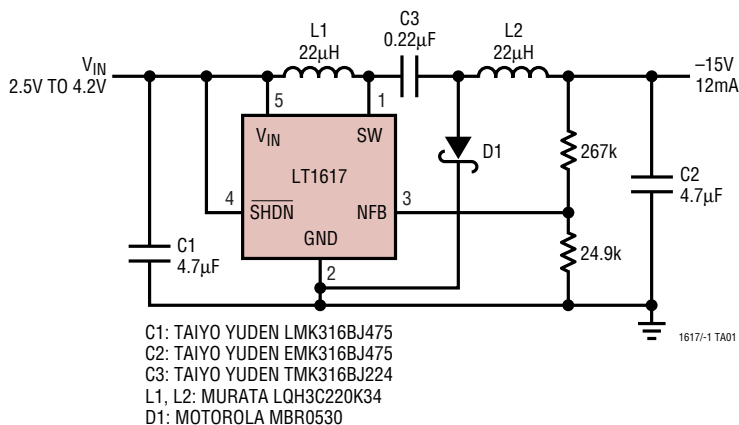

Efficiency

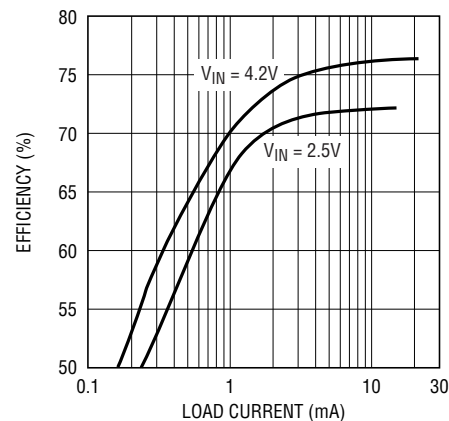

## ABSOLUTE MAXIMUM RATINGS

(Note 1)

$V_{IN}$ , $\overline{SHDN}$ Voltage .....	15V
SW Voltage .....	36V
NFB Voltage .....	-3V
Current into NFB Pin .....	-1mA
Junction Temperature .....	125°C
Operating Temperature Range (Note 2) ..	-40°C to 85°C
Storage Temperature Range .....	-65°C to 150°C
Lead Temperature (Soldering, 10 sec) .....	300°C

## PACKAGE/ORDER INFORMATION

	ORDER PART NUMBER
	LT1617ES5 LT1617ES5-1
	S5 PART MARKING
	LTKF LTKA

Consult factory for Industrial and Military grade parts.

## ELECTRICAL CHARACTERISTICS

The ● denotes the specifications which apply over the full operating temperature range, otherwise specifications are at  $T_A = 25^\circ\text{C}$ .  $V_{IN} = 1.2\text{V}$ ,  $V_{\overline{SHDN}} = 1.2\text{V}$  unless otherwise noted.

PARAMETER	CONDITIONS	MIN	TYP	MAX	UNITS
Minimum Input Voltage	LT1617-1			1.0	V
	LT1617			1.2	V
Quiescent Current	Not Switching $V_{\overline{SHDN}} = 0\text{V}$		20	30	$\mu\text{A}$
				1	$\mu\text{A}$
FB Comparator Trip Point		● -1.205	-1.23	-1.255	V
FB Comparator Hysteresis			8		mV
Output Voltage Line Regulation	$1.2\text{V} < V_{IN} < 12\text{V}$		0.05	0.1	%/V
FB Pin Bias Current (Note 3)	$V_{NFB} = -1.23\text{V}$	● 1.3	2	2.7	$\mu\text{A}$
Switch Off Time			400		ns
Switch $V_{CESAT}$	$I_{SW} = 60\text{mA}$ (LT1617-1) $I_{SW} = 300\text{mA}$ (LT1617)		85	120	mV
			250	350	mV
Switch Current Limit	LT1617-1 LT1617	75	100	125	mA
		300	350	400	mA
$\overline{SHDN}$ Pin Current	$V_{\overline{SHDN}} = 1.2\text{V}$ $V_{\overline{SHDN}} = 5\text{V}$		2	3	$\mu\text{A}$
			8	12	$\mu\text{A}$
$\overline{SHDN}$ Input Voltage High		0.9			V
$\overline{SHDN}$ Input Voltage Low				0.25	V
Switch Leakage Current	Switch Off, $V_{SW} = 5\text{V}$		0.01	5	$\mu\text{A}$

**Note 1:** Absolute Maximum Ratings are those values beyond which the life of a device may be impaired.

**Note 2:** The LT1617 and LT1617-1 are guaranteed to meet specifications from 0°C to 70°C. Specifications over the -40°C to 85°C operating temperature range are assured by design, characterization and correlation with statistical process controls.

**Note 3:** Bias current flows out of the NFB pin.

## TYPICAL PERFORMANCE CHARACTERISTICS

**Switch Saturation Voltage (V<sub>CESAT</sub>)**

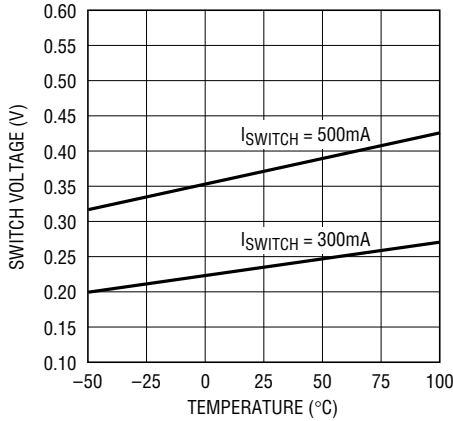

1617-1 G01

**Feedback Pin Voltage and Bias Current**

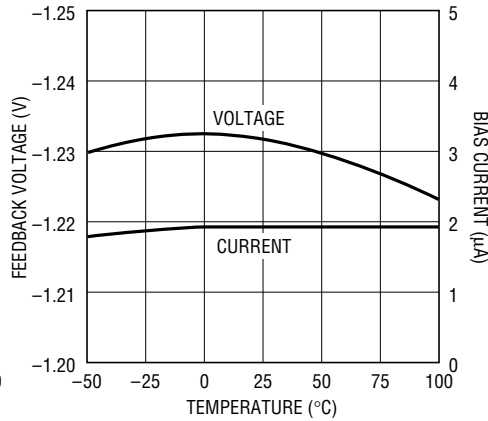

1617-1 G02

**Quiescent Current**

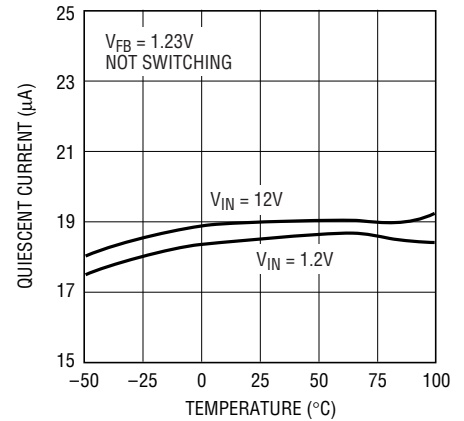

1617-1 G03

**Switch Off Time**

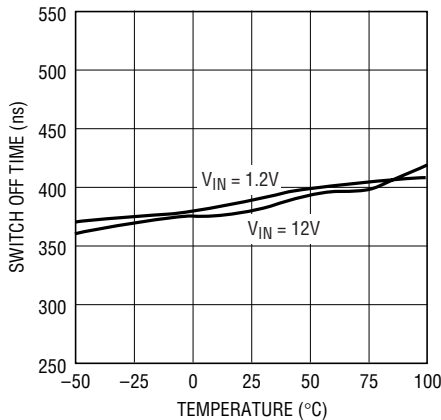

1617-1 G04

**Switch Current Limit**

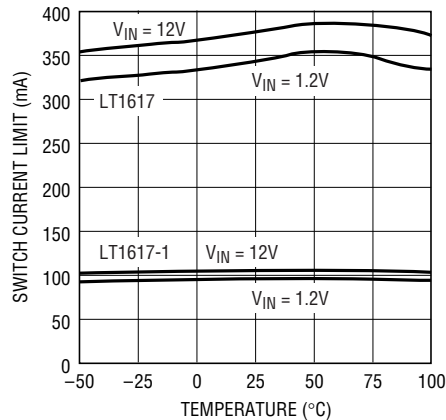

1617-1 G05

**Shutdown Pin Current**

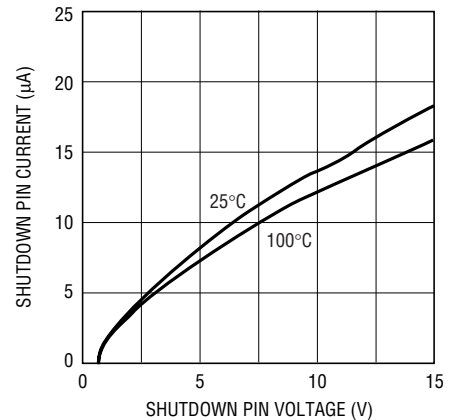

1617-1 G06

## PIN FUNCTIONS

**SW (Pin 1):** Switch Pin. This is the collector of the internal NPN power switch. Minimize the metal trace area connected to this pin to minimize EMI.

**GND (Pin 2):** Ground. Tie this pin directly to the local ground plane.

**NFB (Pin 3):** Feedback Pin. Set the output voltage by selecting values for R1 and R2 (see Figure 1):

$$R1 = \frac{|V_{OUT}| - 1.23}{\frac{1.23}{R2} + (2 \cdot 10^{-6})}$$

**SHDN (Pin 4):** Shutdown Pin. Tie this pin to 0.9V or higher to enable the device. Tie below 0.25V to turn off the device.

**V<sub>IN</sub> (Pin 5):** Input Supply Pin. Bypass this pin with a capacitor as close to the device as possible.

**BLOCK DIAGRAM**

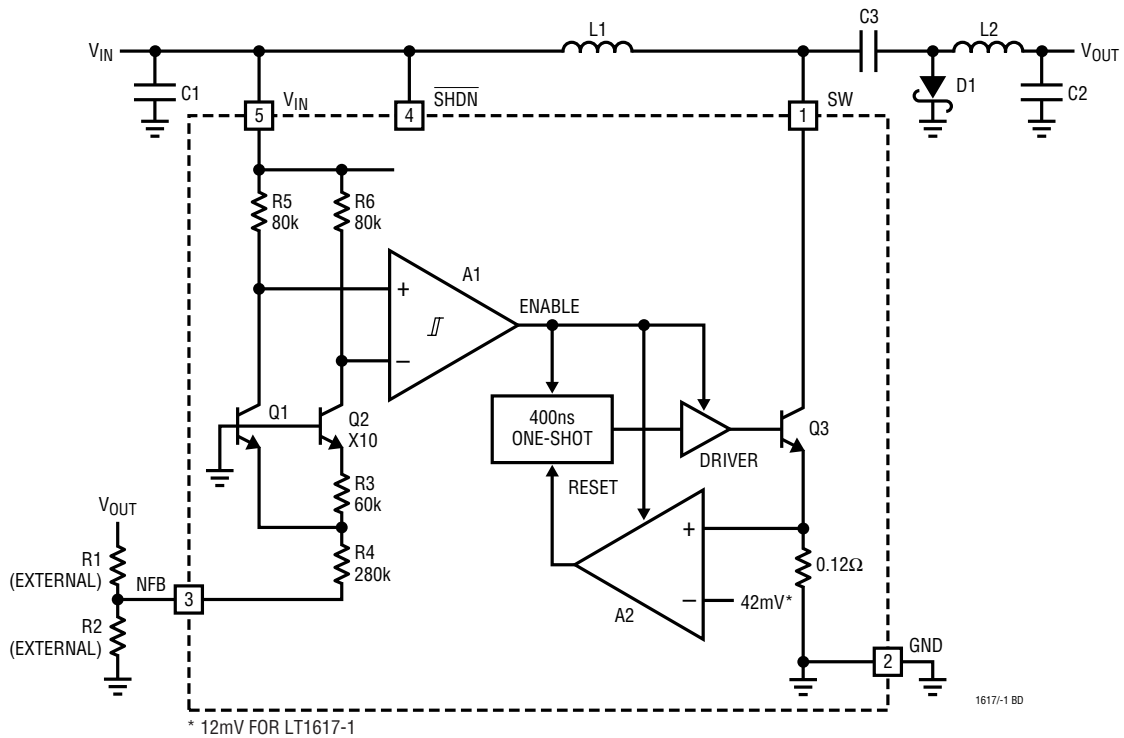

Figure 1. LT1617 Block Diagram

**OPERATION**

The LT1617 uses a constant off-time control scheme to provide high efficiencies over a wide range of output current. Operation can be best understood by referring to the block diagram in Figure 1. Q1 and Q2 along with R3 and R4 form a bandgap reference used to regulate the output voltage. When the voltage at the NFB pin is slightly below  $-1.23\text{V}$ , comparator A1 disables most of the internal circuitry. Output current is then provided by capacitor C2, which slowly discharges until the voltage at the NFB pin goes above the hysteresis point of A1 (typical hysteresis at the NFB pin is  $8\text{mV}$ ). A1 then enables the internal circuitry, turns on power switch Q3, and the current in

inductors L1 and L2 begins ramping up. Once the switch current reaches  $350\text{mA}$ , comparator A2 resets the one-shot, which turns off Q3 for  $400\text{ns}$ . L2 continues to deliver current to the output while Q3 is off. Q3 turns on again and the inductor currents ramp back up until the switch current reaches  $350\text{mA}$ , then A2 again resets the one-shot. This switching action continues until the output voltage is charged up (until the NFB pin reaches  $-1.23\text{V}$ ), then A1 turns off the internal circuitry and the cycle repeats. The LT1617-1 operates in the same manner, except the switch current is limited to  $100\text{mA}$  (the A2 reference voltage is  $12\text{mV}$  instead of  $42\text{mV}$ ).

## APPLICATIONS INFORMATION

### Choosing an Inductor

Several recommended inductors that work well with the LT1617 and LT1617-1 are listed in Table 1, although there are many other manufacturers and devices that can be used. Consult each manufacturer for more detailed information and for their entire selection of related parts. Many different sizes and shapes are available. Use the equations and recommendations in the next few sections to find the correct inductance value for your design.

**Table 1. Recommended Inductors**

PART	VALUE (μH)	MAX DCR (Ω)	VENDOR
LQH3C4R7	4.7	0.26	Murata (714) 852-2001 www.murata.com
LQH3C100	10	0.30	
LQH3C220	22	0.92	
CD43-4R7	4.7	0.11	Sumida (847) 956-0666 www.sumida.com
CD43-100	10	0.18	
CDRH4D18-4R7	4.7	0.16	
CDRH4D18-100	10	0.20	
DO1608-472	4.7	0.09	Coilcraft (847) 639-6400 www.coilcraft.com
DO1608-103	10	0.16	
DO1608-223	22		

### Inductor Selection—Inverting Regulator

The formula below calculates the appropriate inductor value to be used for an inverting regulator using the LT1617 or LT1617-1 (or at least provides a good starting point). This value provides a good tradeoff in inductor size and system performance. Pick a standard inductor close to this value (both inductors should be the same value). A larger value can be used to slightly increase the available output current, but limit it to around twice the value calculated below, as too large of an inductance will increase the output voltage ripple without providing much additional output current. A smaller value can be used (especially for systems with output voltages greater than 12V) to give a smaller physical size. Inductance can be calculated as:

$$L = 2 \left( \frac{|V_{OUT}| + V_D}{I_{LIM}} \right) t_{OFF}$$

where  $V_D = 0.4V$  (Schottky diode voltage),  $I_{LIM} = 350mA$  or  $100mA$ , and  $t_{OFF} = 400ns$ .

For higher output voltages, the formula above will give large inductance values. For a 2V to 20V converter (typical LCD bias application), a 47μH inductor is called for with the above equation, but a 10μH or 22μH inductor could be used without excessive reduction in maximum output current.

### Inductor Selection—Inverting Charge Pump Regulator

For the inverting regulator, the voltage seen by the internal power switch is equal to the sum of the absolute value of the input and output voltages, so that generating high output voltages from a high input voltage source will often exceed the 36V maximum switch rating. For instance, a 12V to -30V converter using the inverting topology would generate 42V on the SW pin, exceeding its maximum rating. For such a system, an inverting charge pump is the best topology.

The formula below calculates the approximate inductor value to be used for an inverting charge pump regulator using the LT1617. As for the boost inductor selection, a larger or smaller value can be used. For designs with varying  $V_{IN}$  such as battery powered applications, use the minimum  $V_{IN}$  value in the equation below.

$$L = \frac{|V_{OUT}| - V_{IN(MIN)} + V_D}{I_{LIM}} t_{OFF}$$

### Current Limit Overshoot

For the constant off-time control scheme of the LT1617, the power switch is turned off only after the 350mA (or 100mA) current limit is reached. There is a 100ns delay between the time when the current limit is reached and when the switch actually turns off. During this delay, the inductor current exceeds the current limit by a small amount. The peak inductor current can be calculated by:

$$I_{PEAK} = I_{LIM} + \left( \frac{V_{IN(MAX)} - V_{SAT}}{L} \right) 100ns$$

Where  $V_{SAT} = 0.25V$  (switch saturation voltage). The current overshoot will be most evident for systems with high input voltages and for systems where smaller induc-

## APPLICATIONS INFORMATION

tor values are used. This overshoot can be beneficial as it helps increase the amount of available output current for smaller inductor values. This will be the peak current seen by the inductor (and the diode) during normal operation. For designs using small inductance values (especially at input voltages greater than 5V), the current limit overshoot can be quite high. Although it is internally current limited to 350mA, the power switch of the LT1617 can handle larger currents without problem, but the overall efficiency will suffer. Best results will be obtained when  $I_{PEAK}$  is kept below 700mA for the LT1617 and below 400mA for the LT1617-1.

### Capacitor Selection

Low ESR (Equivalent Series Resistance) capacitors should be used at the output to minimize the output ripple voltage. Multilayer ceramic capacitors are the best choice, as they have a very low ESR and are available in very small packages. Their small size makes them a good companion to the LT1617's SOT-23 package. Solid tantalum capacitors (like the AVX TPS, Sprague 593D families) or OS-CON capacitors can be used, but they will occupy more board area than a ceramic and will have a larger ESR. Always use a capacitor with a sufficient voltage rating.

Ceramic capacitors also make a good choice for the input decoupling capacitor, which should be placed as close as possible to the LT1617. A 4.7 $\mu$ F input capacitor is sufficient for most applications. Table 2 shows a list of several capacitor manufacturers. Consult the manufacturers for more detailed information and for their entire selection of related parts.

### Diode Selection

For most LT1617 applications, the Motorola MBR0520 surface mount Schottky diode (0.5A, 20V) is an ideal choice. Schottky diodes, with their low forward voltage drop and fast switching speed, are the best match for the LT1617. For higher output voltage applications the 30V MBR0530 can be used. Many different manufacturers make equivalent parts, but make sure that the component is rated to handle at least 0.5A. For LT1617-1 applications, a Phillips BAT54 or a Central Semiconductor CMDSH-3 works well.

### Lowering Output Voltage Ripple

Using low ESR capacitors will help minimize the output ripple voltage, but proper selection of the inductor and the output capacitor also plays a big role. The LT1617 provides energy to the load in bursts by ramping up the inductor current, then delivering that current to the load. If too large of an inductor value or too small of a capacitor value is used, the output ripple voltage will increase because the capacitor will be slightly overcharged each burst cycle. To reduce the output ripple, increase the output capacitor value or add a 100pF feed-forward capacitor in the feedback network of the LT1617 (see the circuits in the Typical Applications section). Adding this small, inexpensive 100pF capacitor will greatly reduce the output voltage ripple.

**Table 2. Recommended Capacitors**

CAPACITOR TYPE	VENDOR
Ceramic	Taiyo Yuden (408) 573-4150 www.t-yuden.com
Ceramic	AVX (803) 448-9411 www.avxcorp.com
Ceramic	Murata (714) 852-2001 www.murata.com

TYPICAL APPLICATIONS

5V to -5V Inverting Converter

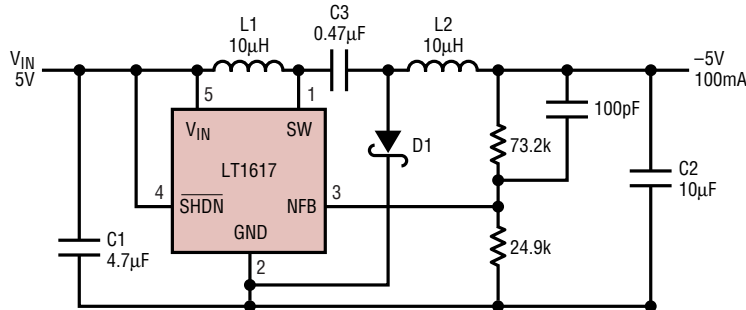

- C1: TAIYO YUDEN LMK316BJ475 (408) 573-4150  
 C2: TAIYO YUDEN JMK316BJ106 (408) 573-4150  
 C3: TAIYO YUDEN EMK212BJ474 (408) 573-4150  
 L1, L2: MURATA LQH3C100K24 (814) 237-1431  
 D1: MOTOROLA MBR0520 (800) 441-2447

-33V Inverting Charge Pump Converter

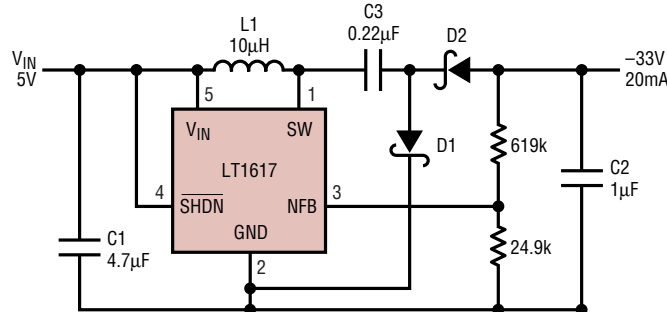

- C1: TAIYO YUDEN LMK316BJ475 (408) 573-4150  
 C2: TAIYO YUDEN GMK316BJ105 (408) 573-4150  
 C3: TAIYO YUDEN GMK212BJ224 (408) 573-4150  
 L1: MURATA LQH3C100K24 (814) 237-1431  
 D1: MOTOROLA MBR0540 (800) 441-2447

1-Cell to -9V Inverting Converter

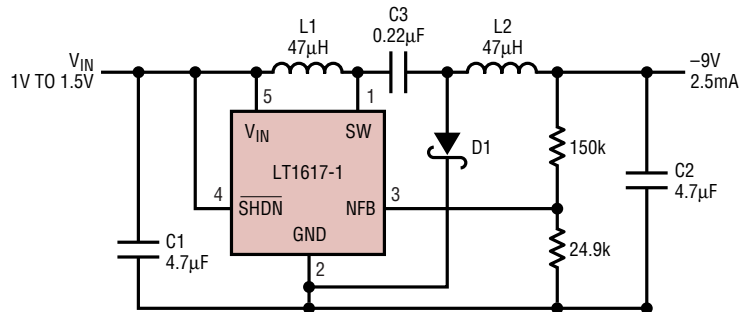

- C1: TAIYO YUDEN LMK316BJ475 (408) 573-4150  
 C2: TAIYO YUDEN EMK316BJ475 (408) 573-4150  
 C3: TAIYO YUDEN TMK316BJ224 (408) 573-4150  
 L1, L2: MURATA LQH3C470K34 (814) 237-1431  
 D1: CENTRAL SEMICONDUCTOR CMDSH-3 (516) 435-1110

## TYPICAL APPLICATIONS

±20V Dual Output Converter with Load Disconnect

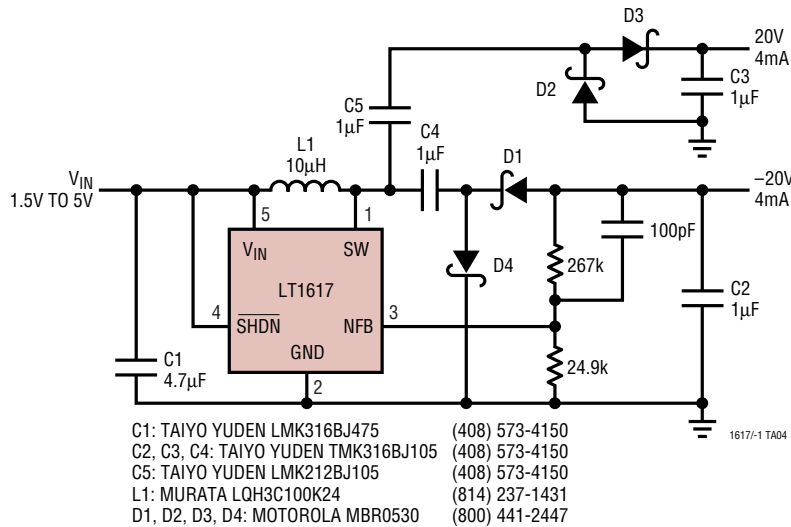

## PACKAGE DESCRIPTION Dimensions in millimeters (inches) unless otherwise noted.

**S5 Package**  
**5-Lead Plastic SOT-23**  
 (LTC DWG # 05-08-1633)

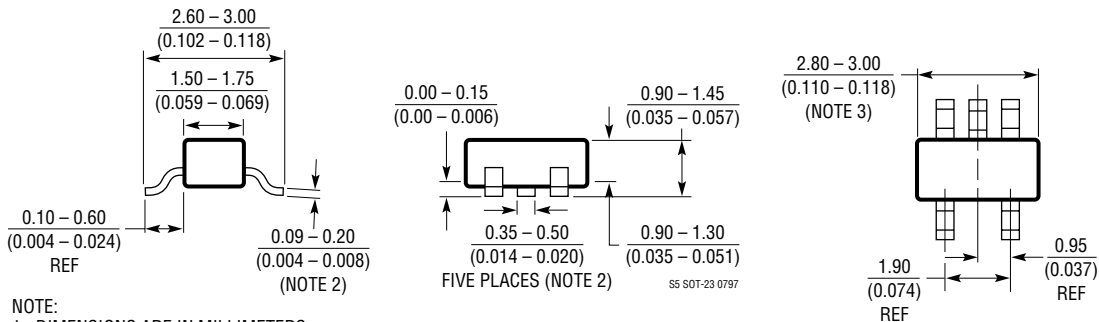

## RELATED PARTS

PART NUMBER	DESCRIPTION	COMMENTS
LT1307	Single-Cell Micropower 600kHz PWM DC/DC Converter	3.3V at 75mA from One Cell, MSOP Package
LT1316	Burst Mode™ Operation DC/DC with Programmable Current Limit	1.5V Minimum, Precise Control of Peak Current Limit
LT1317	2-Cell Micropower DC/DC with Low-Battery Detector	3.3V at 200mA from Two Cells, 600kHz Fixed Frequency
LT1610	Single-Cell Micropower DC/DC Converter	3V at 30mA fro 1V, 1.7MHz Fixed Frequency
LT1611	1.4MHz Inverting Switching Regulator in 5-Lead SOT-23	-5V at 150mA from 5V Input, Tiny SOT-23 Package
LT1613	1.4MHz Switching Regulator in 5-Lead SOT-23	5V at 200mA from 3.3V Input, Tiny SOT-23 Package
LT1615	Micropower DC/DC Converter in 5-Lead SOT-23	20V at 12mA from 2.5V Input, Tiny SOT-23 Package

Burst Mode is a trademark of Linear Technology Corporation

# Mouser Electronics

Authorized Distributor

Click to View Pricing, Inventory, Delivery & Lifecycle Information:

## [Analog Devices Inc.:](#)

[LT1617ES5](#) [LT1617ES5-1#PBF](#) [LT1617ES5#TRM](#) [LT1617ES5-1#TR](#) [LT1617ES5-1#TRPBF](#) [LT1617ES5#TRMPBF](#)  
[LT1617ES5#TRPBF](#) [LT1617ES5#TR](#) [LT1617ES5-1#TRM](#) [LT1617ES5-1](#) [LT1617ES5-1#TRMPBF](#) [LT1617ES5#PBF](#)