

5V Low Power RS232 Transceiver with 2 Receivers Active in Shutdown

FEATURES

- Operates from a Single 5V Supply
- Low Supply Current: $I_{CC} = 220\mu A$
- $I_{CC} = 35\mu A$ in Shutdown Mode with Both Receivers Kept Alive
- ESD Protection Over $\pm 10kV$
- Uses Small Capacitors: $0.1\mu F$
- Operates to 120kbaud
- Output Overvoltage Does Not Force Current Back into Supplies
- RS232 I/O Lines Can Be Forced to $\pm 25V$ Without Damage
- Pin Compatible with LT1180A

APPLICATIONS

- Notebook Computers
- Palmtop Computers

DESCRIPTION

The LTC[®]1384 is an ultra-low power 2-driver/2-receiver RS232 transceiver that operates from a single 5V supply. The charge pump requires only four space-saving $0.1\mu F$ capacitors.

The transceiver operates in one of two modes, Normal and Shutdown. In the Normal mode, I_{CC} is only $220\mu A$ with the driver outputs unloaded. In the Shutdown mode, the charge pump is turned off, the driver outputs are forced into three-state, both receivers are kept active and I_{CC} drops to $35\mu A$. The receiver outputs may be forced into three-state at any time using the receiver enable (RX \overline{EN}) pin.

The LTC1384 is fully compliant with all data rate and overvoltage RS232 specifications. The transceiver can operate up to 120kbaud with a $2500pF$, $3k\Omega$ load. Both driver outputs and receiver inputs can be forced to $\pm 25V$ without damage and can survive multiple $\pm 10kV$ ESD strikes.

LT, LTC and LT are registered trademarks of Linear Technology Corporation.

TYPICAL APPLICATION

2-Drivers/2-Receivers with Shutdown and Receiver Enable

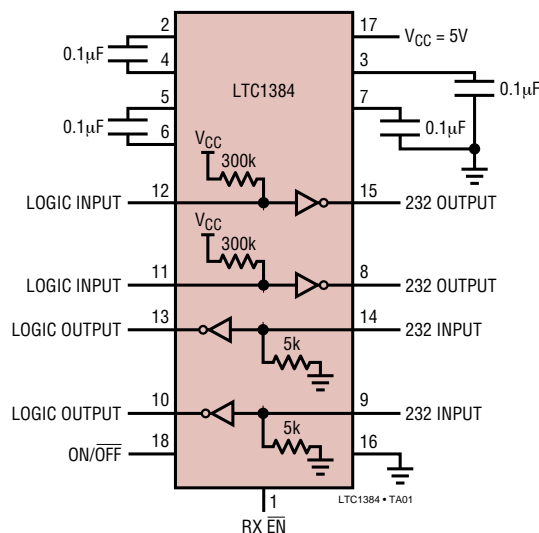

Quiescent and Shutdown Supply Current vs Temperature

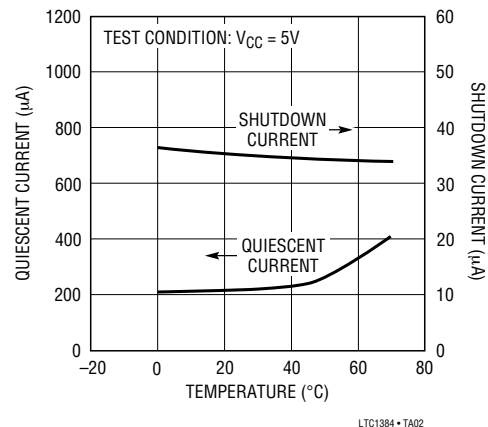

LTC1384 • TA02

ABSOLUTE MAXIMUM RATINGS

Supply Voltage (V_{CC})	6V	Short-Circuit Duration	
Input Voltage		V^+	30 sec
Driver	-0.3V to $V_{CC} + 0.3V$	V^-	30 sec
Receiver	-25V to 25V	Driver Output	Indefinite
Digital Input	-0.3V to $V_{CC} + 0.3V$	Receiver Output	Indefinite
Output Voltage		Operating Temperature Range	
Driver	-25V to 25V	LTC1384C	0°C to 70°C
Receiver	-0.3V to $V_{CC} + 0.3V$	LTC1384I	-40°C to 85°C
		Storage Temperature Range	-65°C to 150°C
		Lead Temperature (Soldering, 10 sec)	300°C

PACKAGE/ORDER INFORMATION

<p>TOP VIEW</p> <p>RX EN 1, C1+ 2, V+ 3, C1- 4, C2+ 5, C2- 6, V- 7, TR2 OUT 8, RX2 IN 9, NC 10, 20 ON/OFF, 19 VCC, 18 GND, 17 TR1 OUT, 16 RX1 IN, 15 RX1 OUT, 14 TR1 IN, 13 TR2 IN, 12 RX2 OUT, 11 NC</p> <p>G PACKAGE 20-LEAD SSOP</p> <p>$T_{JMAX} = 125^{\circ}C, \theta_{JA} = 135^{\circ}C/W$</p>	<p>ORDER PART NUMBER</p> <p>LTC1384CG LTC1384IG</p>	<p>TOP VIEW</p> <p>RX EN 1, C1+ 2, V+ 3, C1- 4, C2+ 5, C2- 6, V- 7, TR2 OUT 8, RX2 IN 9, 18 ON/OFF, 17 VCC, 16 GND, 15 TR1 OUT, 14 RX1 IN, 13 RX1 OUT, 12 TR1 IN, 11 TR2 IN, 10 RX2 OUT</p> <p>N PACKAGE 18-LEAD PDIP</p> <p>SW PACKAGE 18-LEAD PLASTIC SO</p> <p>$T_{JMAX} = 125^{\circ}C, \theta_{JA} = 65^{\circ}C/W$ $T_{JMAX} = 125^{\circ}C, \theta_{JA} = 85^{\circ}C/W$</p>	<p>ORDER PART NUMBER</p> <p>LTC1384CN LTC1384CSW LTC1384IN LTC1384ISW</p>
---	---	--	---

Consult LTC Marketing for parts specified with wider operating temperature ranges.

DC ELECTRICAL CHARACTERISTICS

The ● denotes specifications which apply over the full operating temperature range. $V_{CC} = 5V$, $C1 = C2 = C3 = C4 = 0.1\mu F$, $V_{ON/OFF} = V_{CC}$, $RX\ EN = 0V$, unless otherwise noted.

PARAMETER	CONDITIONS	MIN	TYP	MAX	UNITS	
Any Driver						
Output Voltage Swing	3k to GND	Positive ● Negative ●	5.0 7.0	-5.0 -6.5	V V	
Logic Input Voltage Level	Input Low Level ($V_{OUT} = High$) Input High Level ($V_{OUT} = Low$)	●	1.4	0.8	V	
Logic Input Current	$V_{IN} = V_{CC}$ $V_{IN} = 0V$	●	-20	5	μA μA	
Output Short-Circuit Current	$V_{OUT} = 0V$		±9	±12	mA	
Output Leakage Current	Shutdown or $V_{CC} = 0V$ (Note 3), $V_{OUT} = \pm 10V$	●	±10	±500	μA	
Any Receiver						
Input Voltage Thresholds	Input Low Threshold Input High Threshold	●	0.8	1.3	V	
		●	1.7	2.4	V	
Hysteresis		●	0.1	0.4	1	V
Input Resistance	$-10V \leq V_{IN} \leq 10V$		3	5	7	k Ω
Output Voltage	Output Low, $I_{OUT} = -1.6mA$ ($V_{CC} = 5V$) Output High, $I_{OUT} = 160\mu A$ ($V_{CC} = 5V$)	●	0.2	0.4	V	
		●	3.0	3.2	V	

1384fa

DC ELECTRICAL CHARACTERISTICS The ● denotes specifications which apply over the full operating temperature range. $V_{CC} = 5V$, $C1 = C2 = C3 = C4 = 0.1\mu F$, $V_{ON/OFF} = V_{CC}$, $R_X \bar{E}N = 0V$, unless otherwise noted.

PARAMETER	CONDITIONS	MIN	TYP	MAX	UNITS
Output Short-Circuit Current	Sinking Current, $V_{OUT} = V_{CC}$	-15	-40		mA
	Sourcing Current, $V_{OUT} = 0V$	10	20		mA
Output Leakage Current	$\bar{E}N = V_{CC}$, $0V \leq V_{OUT} \leq V_{CC}$	●	1	10	μA
Power Supply Generator					
V^+ Output Voltage	$I_{OUT} = 0mA$		8.0		V
	$I_{OUT} = 8mA$		7.5		V
V^- Output Voltage	$I_{OUT} = 0mA$		-8.0		V
	$I_{OUT} = -8mA$		-7.0		V
Supply Rise Time	Shutdown to Turn-On		0.2		ms
Power Supply					
V_{CC} Supply Current	No Load (Note 2), $0^\circ C$ to $70^\circ C$	●	0.22	0.5	mA
	No Load (Note 2), $-40^\circ C$ to $85^\circ C$	●	0.35	1.0	mA
Supply Leakage Current (V_{CC})	Shutdown (Note 3)	●	35	50	μA
Digital Input Threshold Low		●	1.4	0.8	V
Digital Input Threshold High		●	2.0	1.4	V

AC CHARACTERISTICS The ● denotes specifications which apply over the full operating temperature range. $V_{CC} = 5V$, $C1 = C2 = C3 = C4 = 0.1\mu F$, unless otherwise noted.

PARAMETER	CONDITIONS	MIN	TYP	MAX	UNITS
Slew Rate	$R_L = 3k$, $C_L = 51pF$		8	30	V/ μS
	$R_L = 3k$, $C_L = 2500pF$	3	5		V/ μS
Driver Propagation Delay (TTL to RS232)	t_{HLD} (Figure 1)	●	2	3.5	μS
	t_{LHD} (Figure 1)	●	2	3.5	μS
Receiver Propagation Delay (RS232 to TTL)	t_{HLR} (Figure 2)	●	0.3	0.8	μS
	t_{LHR} (Figure 2)	●	0.3	0.8	μS

Note 1: Absolute Maximum Ratings are those values beyond which the life of the device may be impaired.

Note 3: Measurements made in the Shutdown mode are performed with $V_{ON/OFF} = 0V$.

Note 2: Supply current is measured with driver and receiver outputs unloaded.

TYPICAL PERFORMANCE CHARACTERISTICS

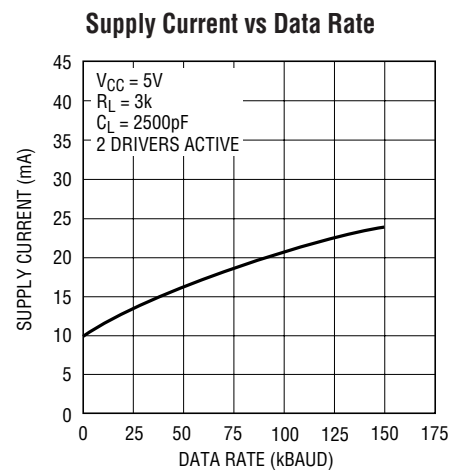
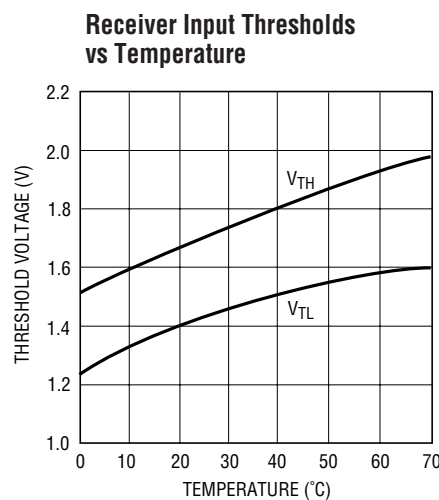
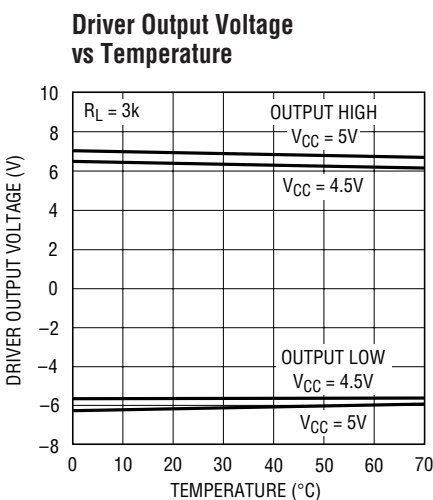

TYPICAL PERFORMANCE CHARACTERISTICS

V_{CC} Supply Current vs Temperature

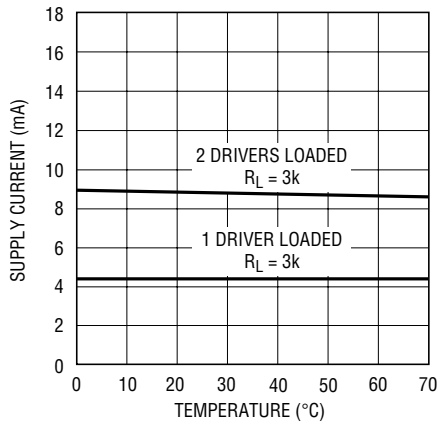

LTC1384 • TPC04

Driver Short-Circuit Current vs Temperature

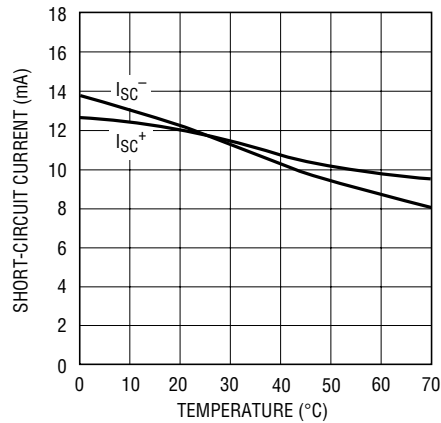

LTC1384 • TPC05

Receiver Short-Circuit Current vs Temperature

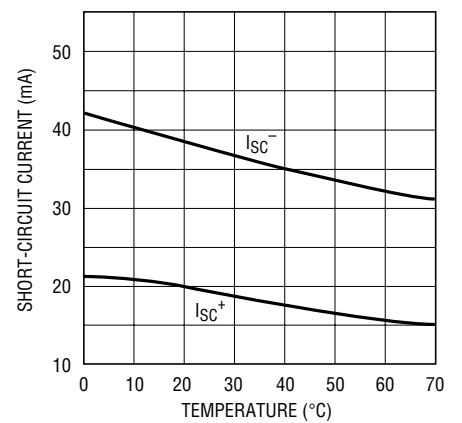

LTC1384 • TPC06

Driver Leakage in Shutdown vs Temperature

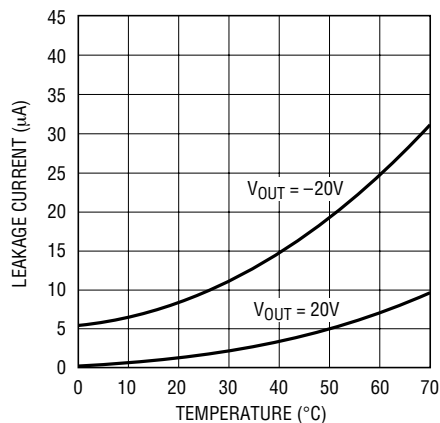

LTC1384 • TPC07

Driver Output Waveforms

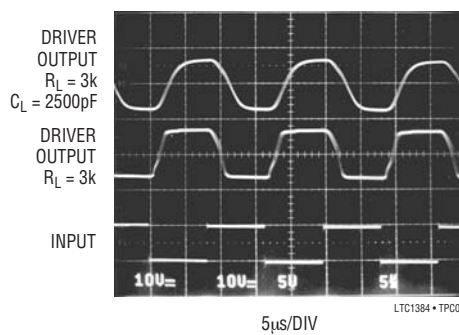

LTC1384 • TPC08

Receiver Output Waveforms

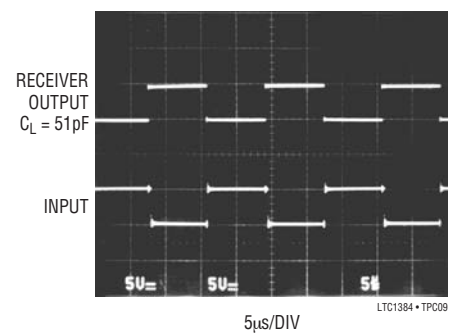

LTC1384 • TPC09

PIN FUNCTIONS

V_{CC}: 5V Input Supply Pin. This pin should be decoupled with a 0.1 μ F ceramic capacitor.

GND: Ground Pin.

ON/OFF: TTL/CMOS Compatible Shutdown Pin. A logic low puts the device in the Shutdown mode independent of the RX $\overline{\text{EN}}$ pin. The supply current of the device drops to 35 μ A (two receivers alive) and both driver outputs are forced into three-state.

RX $\overline{\text{EN}}$: TTL/CMOS Compatible Receiver Enable Pin. A logic high forces the receiver outputs into three-state. A logic low enables the receiver outputs.

V⁺: Positive Supply Output (RS232 Drivers). $V^+ \cong 2V_{CC} - 2V$. This pin requires an external capacitor $C = 0.1\mu\text{F}$ for charge storage. The capacitor may be tied to ground or V_{CC} . With multiple devices, the V^+ and V^- pins may share a common capacitor. For large numbers of devices, increasing the size of the shared common storage capacitors is recommended to reduce ripple.

V⁻: Negative Supply Output (RS232 Drivers). $V^- \cong -(2V_{CC} - 2V)$. This pin requires an external capacitor $C = 0.1\mu\text{F}$ for charge storage.

C1⁺, C1⁻, C2⁺, C2⁻: Commutating Capacitor Inputs. These pins require two external capacitors $C = 0.1\mu\text{F}$: one from C1⁺ to C1⁻ and another from C2⁺ to C2⁻. To maintain charge pump efficiency, the capacitor's effective series resistance should be less than 2 Ω .

TR IN: RS232 Driver Input Pins. Inputs are TTL/CMOS compatible. The inputs of unused drivers can be left unconnected since 300k input pull-up resistors to V_{CC} are included on chip. To minimize power consumption, the internal driver pull-up resistors are disconnected from V_{CC} in the Shutdown mode.

TR OUT: Driver Outputs at RS232 Voltage Levels. Outputs are in a high impedance state when in the Shutdown or $V_{CC} = 0V$. The driver outputs are protected against ESD to $\pm 10\text{kV}$ for human body model discharges.

RX IN: Receiver Inputs. These pins can be forced to $\pm 25V$ without damage. The receiver inputs are protected against ESD to $\pm 10\text{kV}$ for human body model discharges. Each receiver provides 0.4V of hysteresis for noise immunity.

RX OUT: Receiver Outputs with TTL/CMOS Voltage Levels. A logic high at RX $\overline{\text{EN}}$ puts the outputs into three-state.

SWITCHING TIME WAVEFORMS

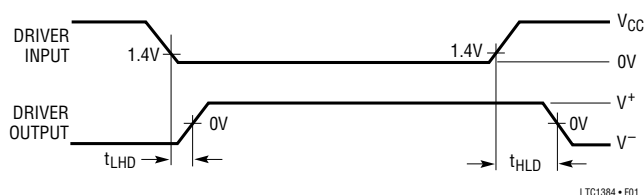

Figure 1. Driver Propagation Delay Timing

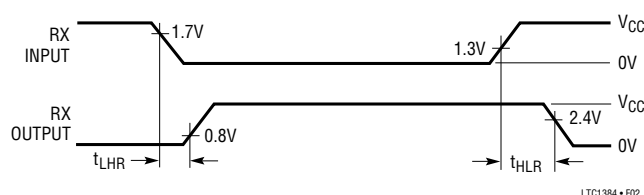
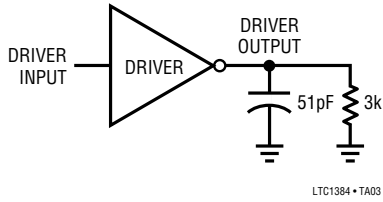

Figure 2. Receiver Propagation Delay Timing

TEST CIRCUITS

Driver Timing Test Load



Receiver Timing Test Load

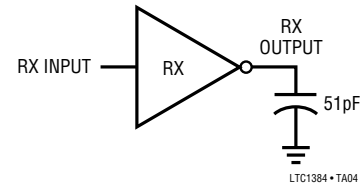

ESD Test Circuit

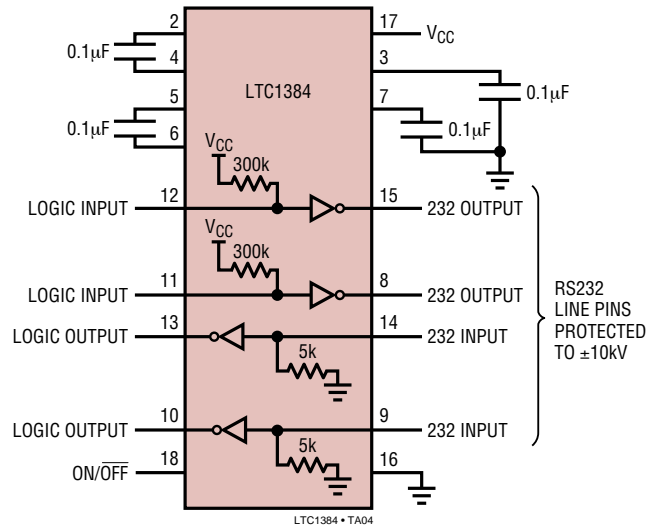

PACKAGE DESCRIPTION

G Package 20-Lead Plastic SSOP (5.3mm) (Reference LTC DWG # 05-08-1640)

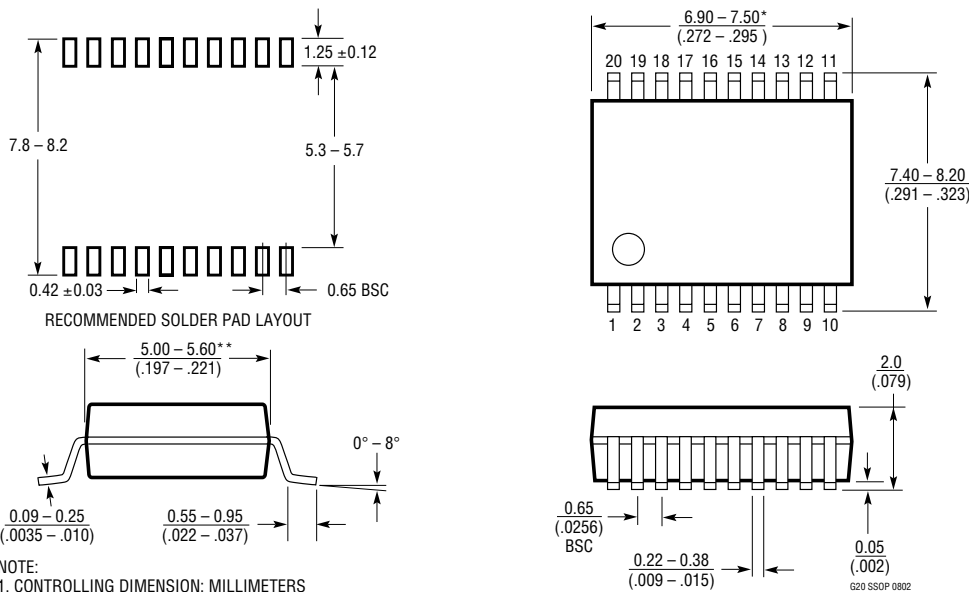

- NOTE:
1. CONTROLLING DIMENSION: MILLIMETERS
 2. DIMENSIONS ARE IN $\frac{\text{MILLIMETERS}}{\text{INCHES}}$
 3. DRAWING NOT TO SCALE
- *DIMENSIONS DO NOT INCLUDE MOLD FLASH. MOLD FLASH SHALL NOT EXCEED .152mm (.006") PER SIDE
- **DIMENSIONS DO NOT INCLUDE INTERLEAD FLASH. INTERLEAD FLASH SHALL NOT EXCEED .254mm (.010") PER SIDE

N Package 18-Lead PDIP (Narrow .300 Inch) (Reference LTC DWG # 05-08-1510)

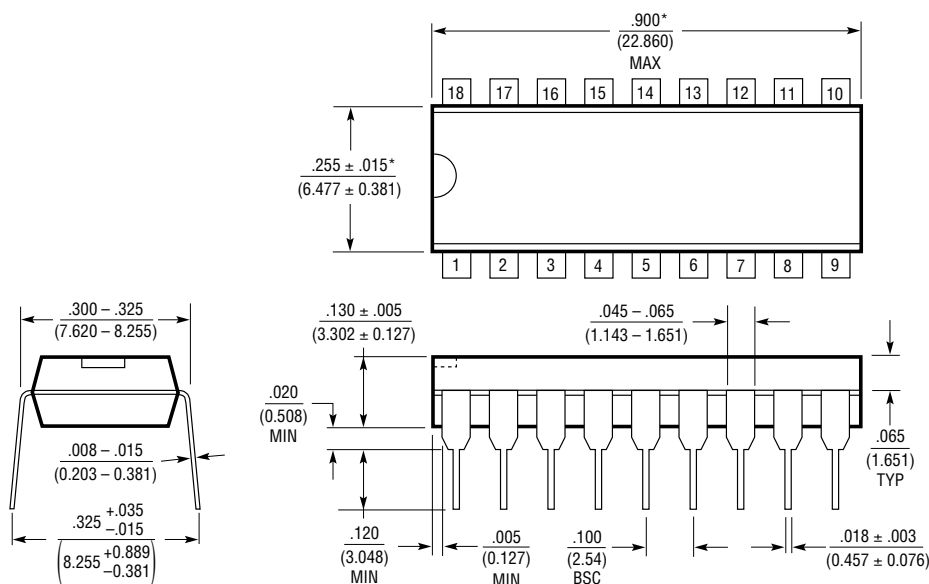

- NOTE:
1. DIMENSIONS ARE $\frac{\text{INCHES}}{\text{MILLIMETERS}}$
- *THESE DIMENSIONS DO NOT INCLUDE MOLD FLASH OR PROTRUSIONS. MOLD FLASH OR PROTRUSIONS SHALL NOT EXCEED .010 INCH (0.254mm)

N18 1002

PACKAGE DESCRIPTION

SW Package
18-Lead Plastic Small Outline (Wide .300 Inch)
 (Reference LTC DWG # 05-08-1620)

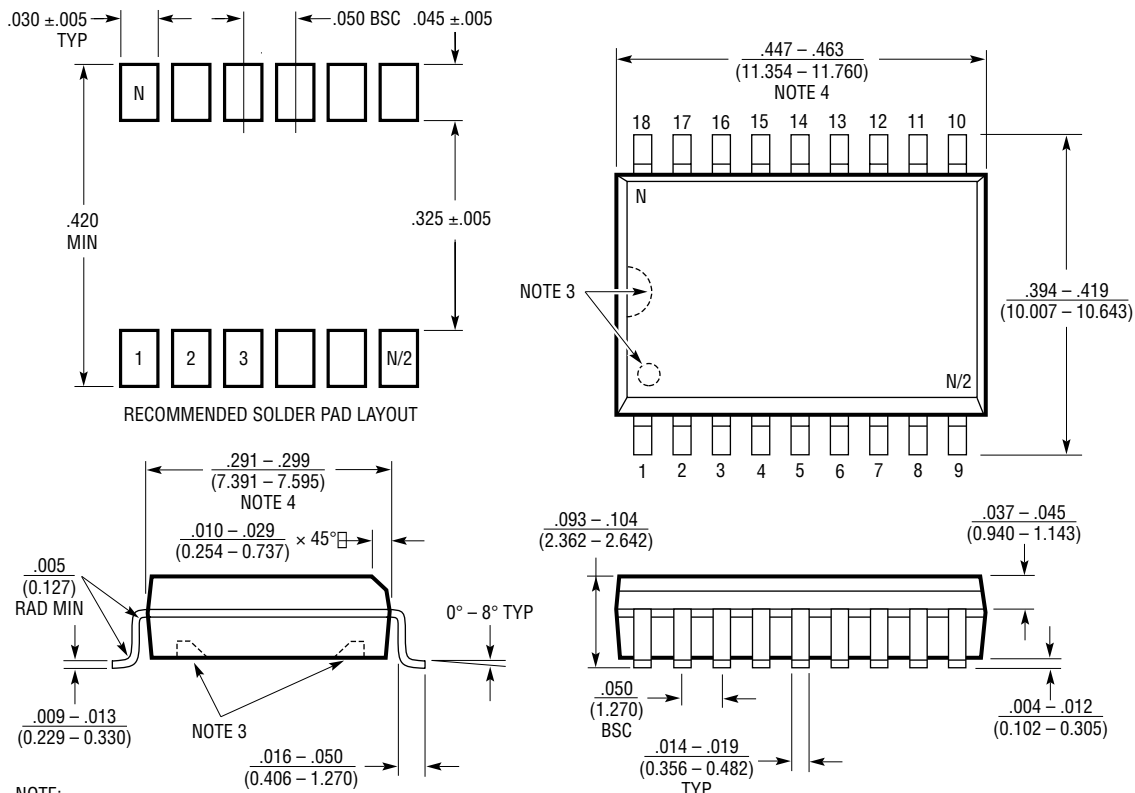

- NOTE:
1. DIMENSIONS IN $\frac{\text{INCHES}}{\text{(MILLIMETERS)}}$
 2. DRAWING NOT TO SCALE
 3. PIN 1 IDENT, NOTCH ON TOP AND CAVITIES ON THE BOTTOM OF PACKAGES ARE THE MANUFACTURING OPTIONS. THE PART MAY BE SUPPLIED WITH OR WITHOUT ANY OF THE OPTIONS
 4. THESE DIMENSIONS DO NOT INCLUDE MOLD FLASH OR PROTRUSIONS. MOLD FLASH OR PROTRUSIONS SHALL NOT EXCEED $.006"$ (0.15mm)

S18 (WIDE) 0502

RELATED PARTS

PART NUMBER	DESCRIPTION	COMMENTS
LT1780/LT1781	5V, 2 Driver, 2 Receiver RS232 Transceivers	± 15 kV ESD per IEC 1000-4
LTC1382	5V, 2 Driver, 2 Receiver RS232 Transceiver	220 μ A Supply Current, 0.2 μ A in Shutdown
LTC1383	5V, 2 Driver, 2 Receiver RS232 Transceiver	220 μ A Supply Current, Narrow 16-pin SO
LTC1385	3.3V, 2 Driver, 2 Receiver RS562 Transceiver	220 μ A Supply Current, 2 Receivers Active in Shutdown
LTC1386	3.3V, 2 Driver, 2 Receiver RS562 Transceiver	220 μ A Supply Current, Narrow 16-pin SO

Mouser Electronics

Authorized Distributor

Click to View Pricing, Inventory, Delivery & Lifecycle Information:

[Analog Devices Inc.:](#)

[LTC1384CG](#) [LTC1384ISW](#) [LTC1384IG](#) [LTC1384CG#TRPBF](#) [LTC1384IN](#) [LTC1384CN](#) [LTC1384CG#PBF](#)
[LTC1384ISW#PBF](#) [LTC1384CSW#PBF](#) [LTC1384ISW#TR](#) [LTC1384CN#PBF](#) [LTC1384CSW](#) [LTC1384ISW#TRPBF](#)
[LTC1384CSW#TRPBF](#) [LTC1384CSW#TR](#) [LTC1384CG#TR](#) [LTC1384IG#PBF](#) [LTC1384IN#PBF](#) [LTC1384IG#TR](#)
[LTC1384IG#TRPBF](#)