

## MAX3523

## Low-Power DOCSIS 3.1 Programmable-Gain Amplifier

### General Description

The MAX3523 is a programmable gain amplifier (PGA) designed to exceed the DOCSIS 3.1 upstream transmit requirements. The PGA meets the DOCSIS 3.1 spurious limits while transmitting a combined output power of 68dBmV over the RF bandwidth of 5MHz to 204MHz. The gain is controlled in 1dB steps over a 60dB range using an SPI 3-wire interface. The use of Maxim's high-voltage CMOS process enables the device to deliver high dynamic range while minimizing power dissipation under a +5V supply rail.

The MAX3523 is available in a 20-pin 5mm x 5mm x 0.75mm TQFN package, and operates over temperature range of 0°C to +70°C.

### Applications

- DOCSIS 3.1 Upstream (D3.1 US)
- Cable Modem (CM)
- Customer Premises Equipment (CPE)

### Benefits and Features

- Delivers +68dBmV Output Power While Meeting DOCSIS 3.1 Requirements
- Covers 5MHz–204MHz Output Bandwidth
- 3.5W Power Consumption with 5V Supply Voltage
- Programmable Power Codes Allow Operation at Reduced Power Dissipation
- Exceeds Spurious Requirements with Fully Loaded OFDM Allocation at +65dBmV at Modem Output
- 20L 5mm x 5mm x 0.75mm TQFN Package with Exposed Paddle

*Ordering Information* appears at end of data sheet.

### Simplified Block Diagram

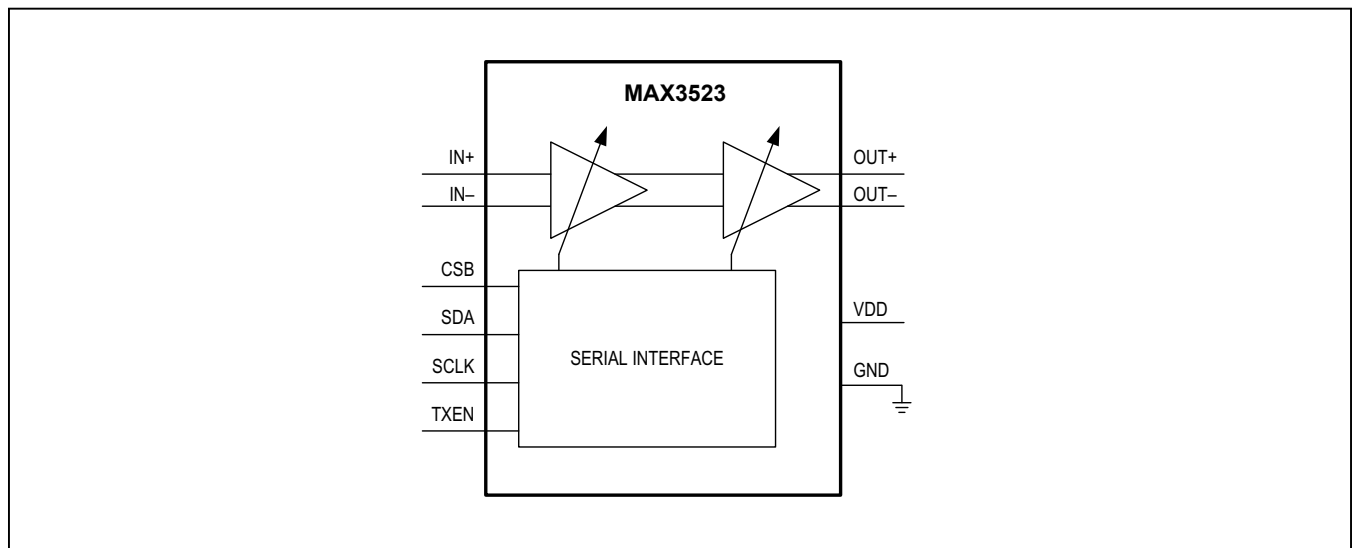

**Absolute Maximum Ratings**

VDD to GND .....	-0.3V to +6.0V	Operating Junction Temperature (Note 4) .....	-40°C to +150°C
TXEN, SDA, SCLK, CSB .....	-0.3V to +6.0V	Storage Temperature Range .....	-65°C to +165°C
IN+, IN- .....	V <sub>DD</sub> - 2.1V to 6V	Lead Temperature (soldering, 10s) .....	+300°C
OUT+, OUT- to GND .....	-0.3V to V <sub>DD</sub> + 5V	Soldering Temperature (reflow) .....	+260°C
RF Input Power .....	+10dBm		
Continuous Power Dissipation (T <sub>A</sub> = 70°C)			
(derate 54mW/°C above T <sub>A</sub> = 70°C) .....	3500mW		

*Stresses beyond those listed under "Absolute Maximum Ratings" may cause permanent damage to the device. These are stress ratings only, and functional operation of the device at these or any other conditions beyond those indicated in the operational sections of the specifications is not implied. Exposure to absolute maximum rating conditions for extended periods may affect device reliability.*

**Package Information**

**20 TQFN-EP**

PACKAGE CODE	T2055+5
Outline Number	<a href="#">21-0140</a>
Land Pattern Number	<a href="#">90-0010</a>
<b>Thermal Resistance, Four-Layer Board:</b>	
Junction to Ambient (θ <sub>JA</sub> )	PCB must be designed for a θ <sub>JA</sub> of 18.5°C/W or lower
Junction to Case (θ <sub>JC</sub> )	2°C/W

For the latest package outline information and land patterns (footprints), go to [www.maximintegrated.com/packages](http://www.maximintegrated.com/packages). Note that a "+", "#", or "-" in the package code indicates RoHS status only. Package drawings may show a different suffix character, but the drawing pertains to the package regardless of RoHS status.

Package thermal resistances were obtained using the method described in JEDEC specification JESD51-7, using a four-layer board. For detailed information on package thermal considerations, refer to [www.maximintegrated.com/thermal-tutorial](http://www.maximintegrated.com/thermal-tutorial).

## Electrical Characteristics

( $V_{DD} = 4.75V$  to  $5.25V$ ,  $V_{GND} = 0V$ ,  $Z_{OUT} = 75\Omega$ , TXEN = high, Gain Code = 63, Power code = 3,  $P_{OUT} = 68dBmV$ ,  $T_A = 0^\circ C$  to  $70^\circ C$ , Typical values are at  $V_{DD} = 5V$ ,  $T_A = +25^\circ C$ , unless otherwise noted. *Typical Application Circuit* as shown. Note 1.)

PARAMETER	SYMBOL	CONDITIONS	MIN	TYP	MAX	UNITS	
<b>DC ELECTRICAL SPECIFICATIONS</b>							
Supply Voltage	$V_{DD}$		4.75	5.0	5.25	V	
Supply Current Transmit Mode	$I_{DD}$	Gain code = 63, power code = 3		700	730	mA	
		Gain code = 63, power code = 2		635			
		Gain code = 63, power code = 1		570			
Supply Current Transmit Disable Mode	$I_{DD}$	TXEN = low		2.5	3.5	mA	
Input High Voltage	$V_{INH}$		2		$V_{DD}$	V	
Input Low Voltage	$V_{INL}$				0.7	V	
Input High Current	$I_{BIASH}$			1		$\mu A$	
Input Low Current	$I_{BIASL}$			-1		$\mu A$	
<b>AC ELECTRICAL SPECIFICATIONS</b>							
Voltage Gain	$A_V$	$Z_{IN} = 100\Omega$ (Note 3), Power Code = 3, $f_{IN} = 10MHz$	Gain code = 63	36.3	37.3	38.3	dB
			Gain code = 53	26.3	27.3	28.3	
			Gain code = 43	16.3	17.3	18.3	
			Gain code = 33	6.3	7.3	8.3	
			Gain code = 23	-3.7	-2.7	-1.7	
			Gain code = 13	-14	-13	-12	
			Gain code = 03		-23		
Voltage Gain Variation with Power Code, Any Gain Code	$\Delta A_V$			$\pm 0.1$		dB	
Gain Rolloff		Voltage gain = -16dB to +37dB, $f_{IN} = 5MHz$ to 204MHz		-0.5		dB	
Gain Step Size		Voltage gain = -16dB to +37dB, $f_{IN} = 10MHz$	0.6	1	1.4	dB	
Transmit-Disable Mode Noise		BW = 160kHz, 5MHz to 204MHz, TXEN = LOW		-66		dBmV	
Isolation in Transmit-Disable Mode		TXEN = LOW		80		dB	
Noise Figure	NF	Transmit mode, voltage gain = +11dB to +37dB		14		dB	
Noise Figure Slope		Transmit mode, voltage gain = -16dB to +37dB		-1		dB/dB	
Transmit-Disable/Transmit-Enable Transient Duration		TXEN input rise/fall time < 0.1 $\mu s$		4		$\mu s$	
Transmit-Disable/Transmit-Enable Transient Amplitude		Gain = 37dB		20		mV <sub>pp</sub>	
		Gain = 3dB		1			
Internal Input Impedance		Differential balanced		200		$\Omega$	
Output Return Loss	S22	5MHz - 204MHz, TXEN = high (Note 2)		13		dB	

## Electrical Characteristics (continued)

( $V_{DD} = 4.75V$  to  $5.25V$ ,  $V_{GND} = 0V$ ,  $Z_{OUT} = 75\Omega$ , TXEN = high, Gain Code = 63, Power code = 3,  $P_{OUT} = 68dBmV$ ,  $T_A = 0^\circ C$  to  $70^\circ C$ , Typical values are at  $V_{DD} = 5V$ ,  $T_A = +25^\circ C$ , unless otherwise noted. *Typical Application Circuit* as shown. Note 1.)

PARAMETER	SYMBOL	CONDITIONS	MIN	TYP	MAX	UNITS
Output Return Loss in Transmit-Disable Mode	S22	5MHz - 204MHz, TXEN = low (Note 2)		14		dB
2nd Harmonic Distortion	HD2	$f_{IN} = 100MHz$ , $V_{OUT} = +68dBmV$		-65		dBc
Two-Tone 2nd-Order Distortion ( $f_1 + f_2$ )	IM2	$f_1 = 100MHz$ , $f_2 = 105MHz$ , $V_{OUT} = +65dBmV/$ tone		-62		dBc
3rd Harmonic Distortion	HD3	$f_{IN} = 65MHz$ , $V_{OUT} = +68dBmV$		-60		dBc
Two-Tone 3rd-Order Distortion	IM3	$f_1 = 195MHz$ , $f_2 = 200MHz$ , $V_{OUT} = +65dBmV/$ tone		-55		dBc
Output Compression at Peak Output		$f = 100MHz$ , GC = 63, output power = +79dBmV		0.3		dB
Modulation Error Ratio	MER	4k FFT, 1024QAM, $f_{IN} = 150MHz$ , BW = 96MHz	$V_{OUT} = +67dBmV$	49		dB
			$V_{OUT} = +68dBmV$	47		
		4k FFT, 1024QAM, $f_{IN} = 192MHz$ , BW = 24MHz	$V_{OUT} = +67dBmV$	51		
			$V_{OUT} = +68dBmV$	46		
CSB to SCLK Rise Setup Time	$t_{SENS}$			20		ns
CSB to SCLK Rise Hold Time	$t_{SENH}$			10		ns
SDA to SCLK Setup Time	$t_{SDAS}$			20		ns
SDA to SCLK Hold Time	$t_{SDAH}$			10		ns
SCLK Pulse-Width High	$t_{SCLKH}$			50		ns
SCLK Pulse-Width Low	$t_{SCLKL}$			50		ns
Maximum SCLK Frequency	$f_{SCLK}$			20		MHz

**Note 1:** Limits are tested at  $T_A = +70^\circ C$ . Limits over the operating temperature range and relevant supply voltage range are guaranteed by design and characterization.

**Note 2:** Output return loss is measured with the LC matching network, as shown in the [Typical Application Circuit](#).

**Note 3:** Effective input impedance with external 200 $\Omega$  resistance in parallel with internal 200 $\Omega$  resistance

**Note 4:** The device is designed for continuous operation up to  $T_J = +125^\circ C$  for 95,000 hours plus  $T_J = +150^\circ C$  for 5,000 hours.

Typical Operating Characteristics

( $T_A = 25^\circ\text{C}$ ,  $P_{OUT} = 68\text{dBmV}$ , TXEN = high, Gain Code = 63, Power Code = 3,  $V_{DD} = 5\text{V}$ , unless otherwise noted.)

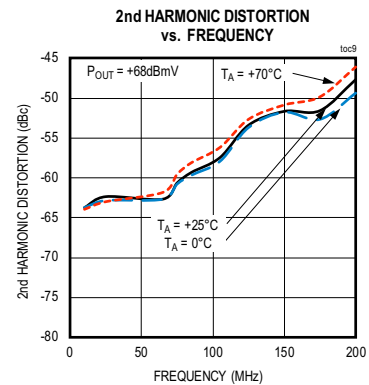
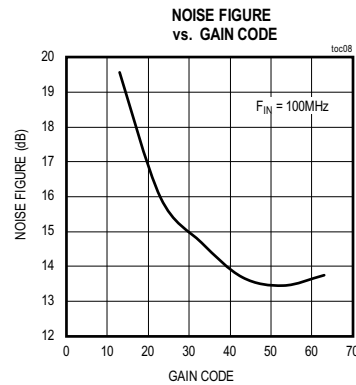
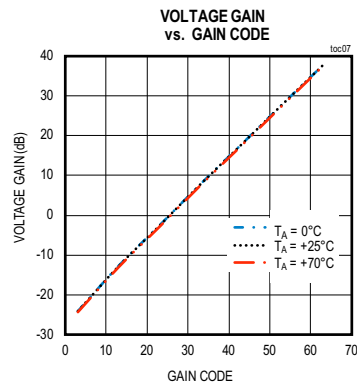
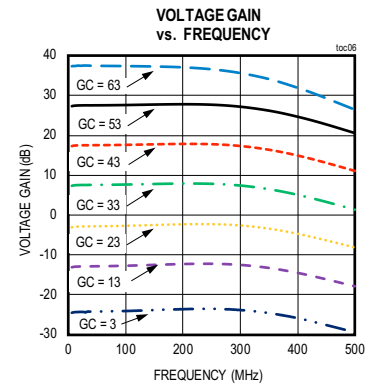
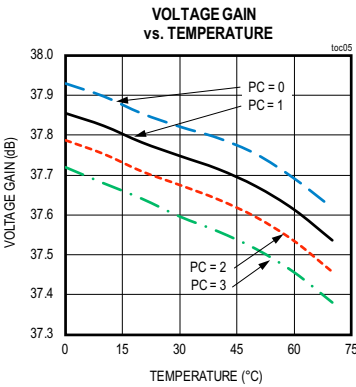
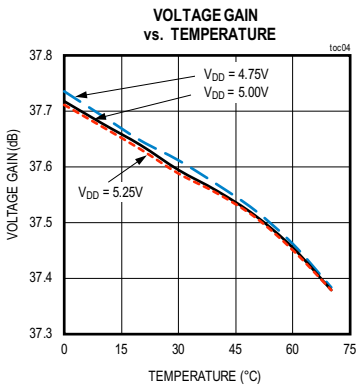
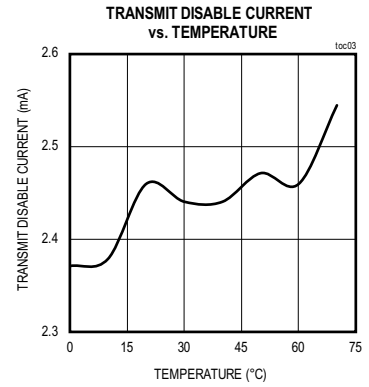
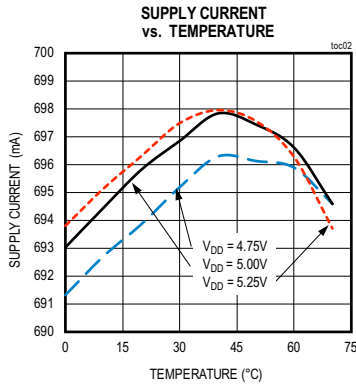
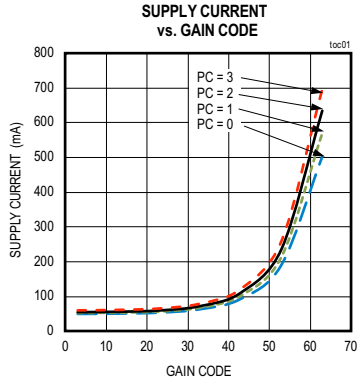

Typical Operating Characteristics (continued)

( $T_A = 25^\circ\text{C}$ ,  $P_{OUT} = 68\text{dBmV}$ , TXEN = high, Gain Code = 63, Power Code = 3,  $V_{DD} = 5\text{V}$ , unless otherwise noted.)

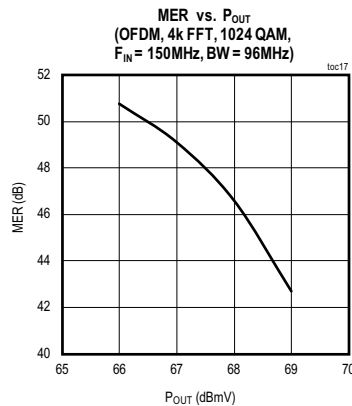
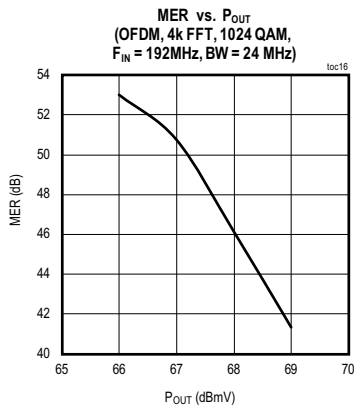
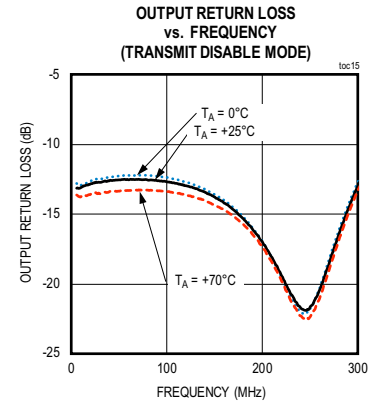
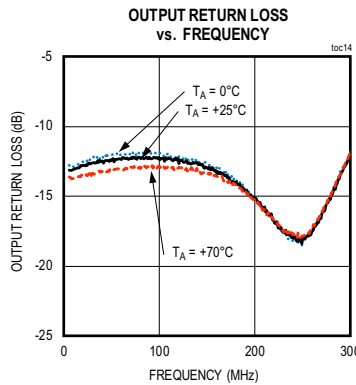
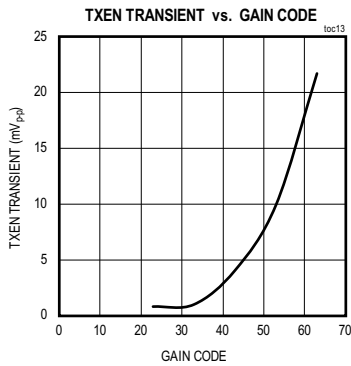
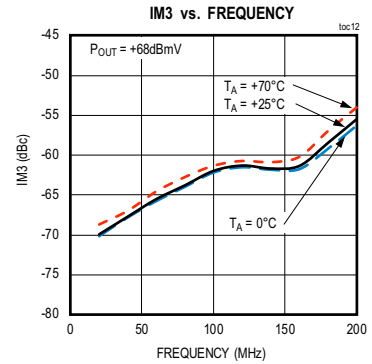
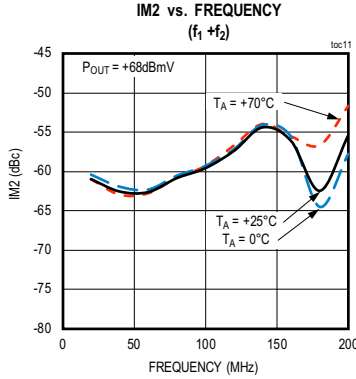
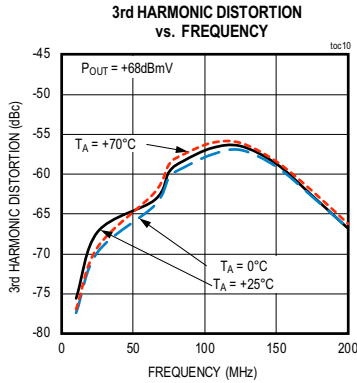

Pin Configuration

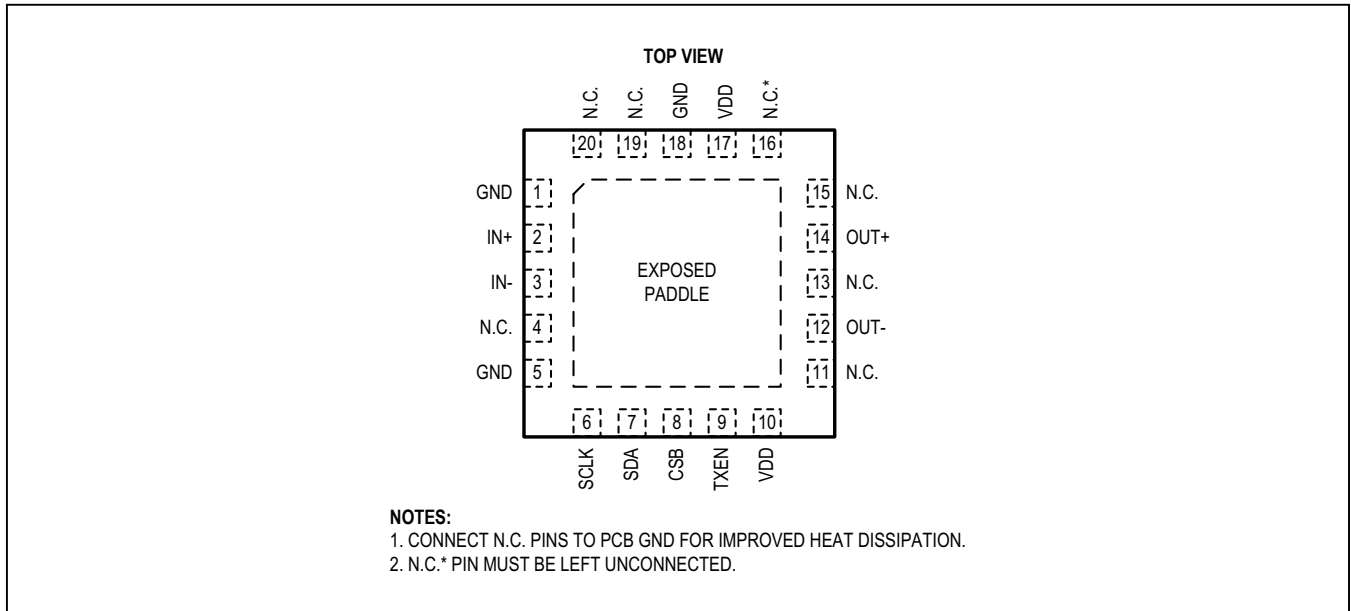

Pin Description

PIN	NAME	FUNCTION
10, 17	VDD	+5V Supply. Connect a 0.1µF capacitor to GND.
2	IN+	Positive Input
3	IN-	Negative Input
8	CSB	Chip Select. Active-low.
7	SDA	Serial Data
6	SCLK	Clock
9	TXEN	Transmit Enable/Disable
4, 11, 13, 15, 19, 20	N.C.	Connect to PCB GND for Improved Heat Dissipation
12	OUT-	PA Negative Output
14	OUT+	PA Positive Output
1, 5, 18	GND	Ground
16	N.C.*	Leave Open
Paddle	GND	Ground

Recommended Operating Conditions

PARAMETER	CONDITIONS
Ambient Temperature Range	0°C to +70°C

Typical Application Circuit

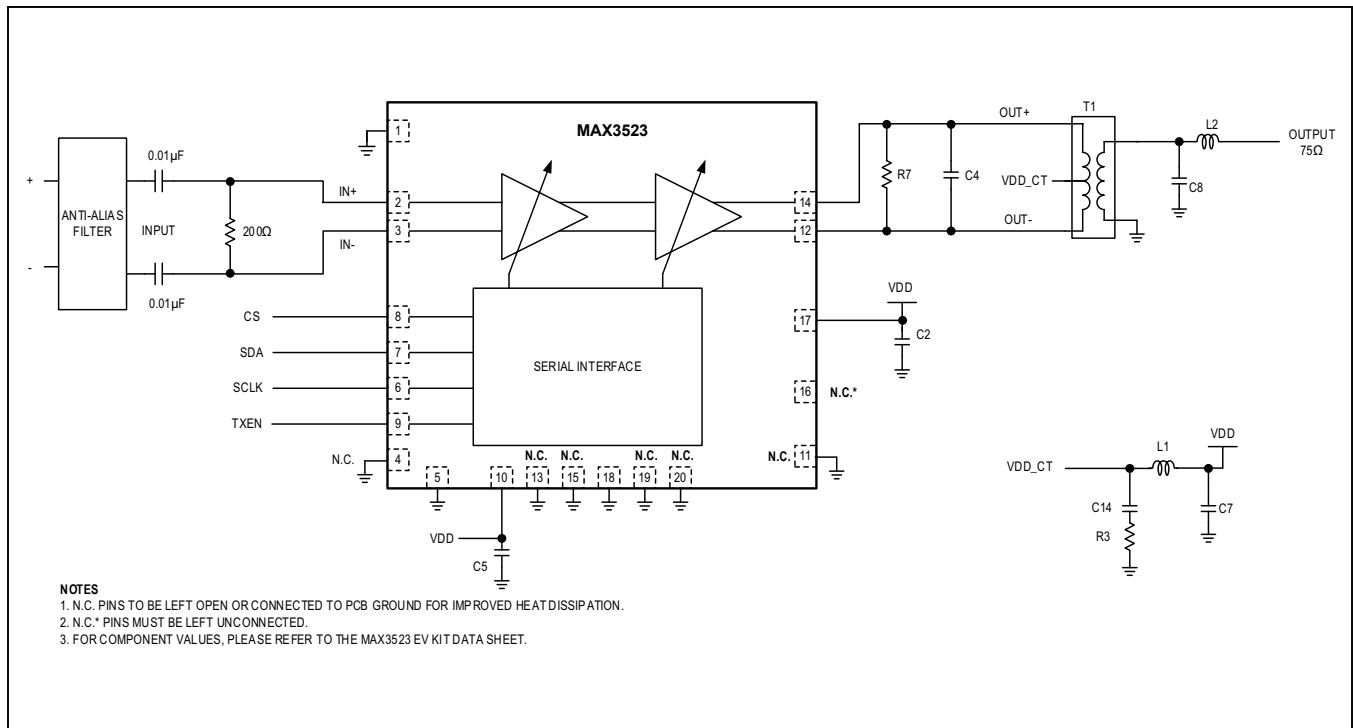

Detailed Description

Programmable-Gain Amplifier

The programmable-gain amplifier (PGA) provides 60dB of output level control in 1dB steps. The gain of the PGA is determined by a 6-bit gain code (GC5–GC0) programmed through the serial-data interface (see [Register Map](#)). Specified performance is achieved when the input is driven differentially.

Four power codes (PC1–PC0) allow the PGA to be used with reduced bias current when distortion performance can be relaxed. In addition, for each power code, bias current is automatically reduced with gain code for maximum efficiency.

The PGA features a differential Class A output stage capable of driving an +68dBmV OFDMA signal from 5MHz–85MHz or two 96MHz +65dBmV OFDMA signals from 5MHz–204MHz into a 75Ω load. This architecture features a differential output that provides superior even-order distortion performance. This requires that a

transformer be used to convert to a single-ended output. In transmit-disable mode, the output amplifiers are powered down, resulting in low output noise while maintaining the impedance match.

3-Wire Serial Programmable Interface (SPI) and Control Registers

The MAX3523 includes a user-programmable register for initializing the part and setting the gain and power consumption. The four MSBs are address bits; the eight least significant bits (LSBs) are used for register data. Data is shifted MSB first.

The serial interface should only be written to when TXEN = low, as is the case between transmit bursts in a DOCSIS environment. Once a new set of register data is clocked in, the corresponding power code and/or gain code does not take effect until the 12th rising edge of SCLK.

**Note:** The registers must be written no earlier than 100μs after the device is powered up.

**SPI Read**

Figure 1 shows a single-byte read transaction. In this example, a single byte is read from the slave by the master. The master first asserts CSB, begins driving SDA with the R/Wb bit having value of 1 indicating this a read transaction and starts toggling SCLK. The slave samples the bits on SDA on the rising edge of SCLK. After the R/Wb bit, the master outputs the 3-bit register addresses starting with the most significant bit following which the master releases the SDA line. The slave then starts driving SDA and outputs the single byte that was requested by the master. After the last bit has been output, the slave three-states SDA on the rising edge of CSB that ends the transaction.

**SPI Write**

Figure 2 shows a single-byte write transaction. In this example, a single byte is written to the slave by the master. The master first asserts CSB, begins driving SDA with the R/Wb bit having value of 0 indicating this a write transaction and starts toggling SCLK. The slave samples the bits on SDA on the rising edge of SCLK. After the R/Wb bit, the master outputs the 3-bit register addresses starting with the most significant bit and then the 8-bit data starting with the most significant bit. The internal registers are updated on the 12th rising edge of SCLK.

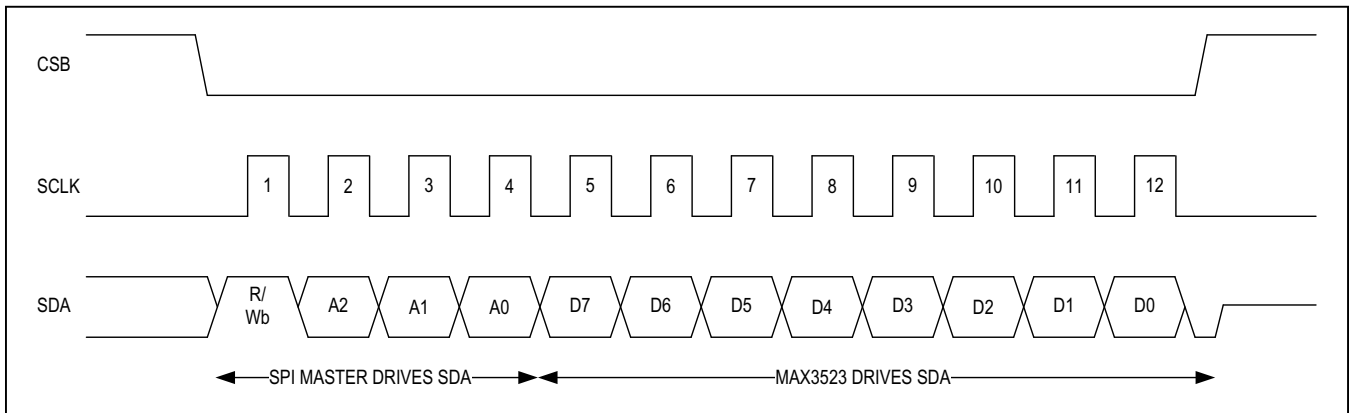

Figure 1. SPI Read Transaction

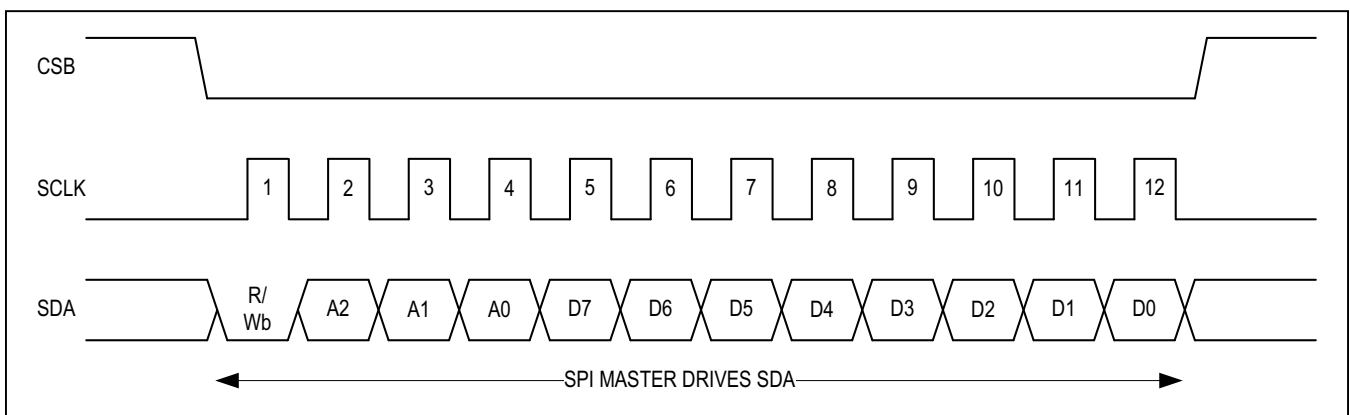

Figure 2. SPI Write Transaction

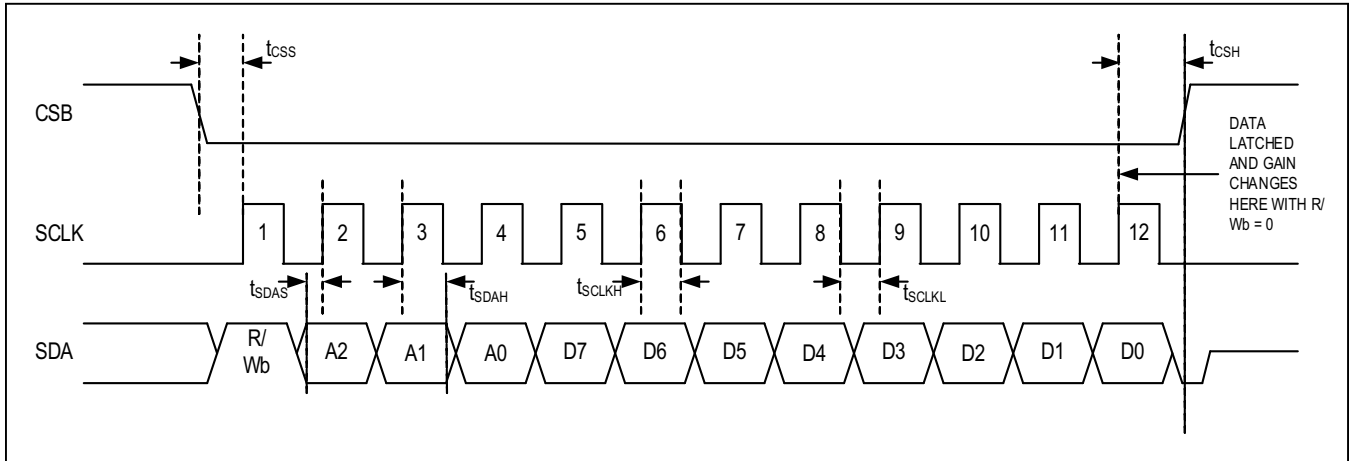

Figure 3. SPI Timing Diagram

### Register Map

ADDRESS	NAME	MSB						LSB
<b>MAIN</b>								
0x00	GAIN[7:0]	PC[1:0]					GC[5:0]	

### Register Details

#### GAIN (0x0)

BIT	7	6	5	4	3	2	1	0
Field	PC[1:0]		GC[5:0]					
Reset	0x0		0x0					
Access Type	Write, Read		Write, Read					

BITFIELD	BITS	DESCRIPTION	DECODE
PC	7:6	Power Code	0x0: MIN POWER 0x3: MAX POWER
GC	5:0	Gain Code	0x0: MIN GAIN 0x3F: MAX GAIN

## Applications Information

### Power Codes

The device is designed to exceed the stringent linearity requirements of DOCSIS 3.1 using power code (PC 3). Using lower power codes (PC = 2, 1 or 0) allows for operation at reduced current levels. The full range of gain codes can be used in any power code. The gain difference between power codes is typically less than 0.1dB.

### Transmit Disable Mode

Between bursts in a DOCSIS system, the MAX3523 can be put in transmit-disable mode by setting TXEN low. The output transient on the cable is kept well below the DOCSIS 3.1 requirement during the TXEN transitions.

If a gain code or power code change is required, the new values of PC and GC should be clocked in during transmit-disable mode (TXEN low). The new operating point of the MAX3523 is set on the 12th rising edge of SCLK. This should be done between transmission bursts.

### Output Circuit

The output circuit is an open-drain differential amplifier. The outputs should be resistively terminated, as shown in the [Typical Application Circuit](#). A 50:75 impedance ratio transformer should be used as the interface between the differential output of the device and the unbalanced 75Ω load.

Amplifier performance depends on the value of the termination resistors. Rated performance is obtained using the R7 termination resistor as shown in the [Typical Application Circuit](#). Increasing the value of this resistor will increase gain and improve SNR at the expense of output return loss.

Transformer core inductance may vary with temperature. Adequate primary inductance must be present to sustain broadband output capability as temperatures vary.

### Input Circuit

The differential input impedance of the MAX3523 is 200Ω. In a typical application, however, it is driven from a 100Ω differential source, requiring an external 200Ω matching resistor, as shown in the [Typical Application Circuit](#).

The device has sufficient gain and linearity to produce an output level of +68dBmV when driven with a +31dBmV input signal. If an input level greater than +31dBmV is used, the 3rd-order distortion performance degrades.

## Layout Issues

A well-designed printed circuit board (PCB) is an essential part of an RF circuit. For best performance, pay attention to power-supply layout issues as well as the output circuit layout. The MAX3523 evaluation (EV) board layout can be utilized as a guide during PCB design. Its electrical performance has been thoroughly tested, making it an excellent reference. Refer to the MAX3523 EV kit for additional information.

### Output Circuit Layout

Keep the length of the output traces as short as possible. Series inductance between the part and the transformer will degrade the performance at the higher end of the operating frequency range. To maintain the balance of the output network, match the length of the differential traces as closely as possible.

### Power-Supply Layout

For minimal coupling between different sections of the IC, the ideal power-supply layout is a star configuration. This configuration has a large-value decoupling capacitor at the central power-supply node. The power-supply traces branch out from this node, each going to a separate power-supply node in the circuit. At the end of each of these traces is a decoupling capacitor that provides a very low impedance at the frequency of interest. This arrangement provides local power-supply decoupling at each power-supply pin. The power-supply traces must be capable of carrying the maximum current without significant voltage drop.

### Exposed Pad Thermal Considerations

The exposed pad (EP) of the MAX3523's 20-pin TQFN package provides a low thermal resistance path to the die. It is important that the PCB on which the device is mounted be designed to conduct heat from this contact. In addition, the EP should be provided with a low-inductance path to electrical ground. The MAX3523 EV board is an example of a layout that provides optimal thermal and electrical performance.

## Ordering Information

PART NUMBER	TEMP RANGE	PIN-PACKAGE
MAX3523ETP+	0°C to +70°C	20 TQFN-EP*
MAX3523ETP+T	0°C to +70°C	20 TQFN-EP*

\* EP = Exposed pad.

+ Denotes a lead(Pb)-free/RoHS-compliant package.

T Denotes tape-and-reel.

**Revision History**

REVISION NUMBER	REVISION DATE	DESCRIPTION	PAGES CHANGED
0	6/18	Initial release	—

For pricing, delivery, and ordering information, please contact Maxim Direct at 1-888-629-4642, or visit Maxim Integrated's website at [www.maximintegrated.com](http://www.maximintegrated.com).

*Maxim Integrated cannot assume responsibility for use of any circuitry other than circuitry entirely embodied in a Maxim Integrated product. No circuit patent licenses are implied. Maxim Integrated reserves the right to change the circuitry and specifications without notice at any time. The parametric values (min and max limits) shown in the Electrical Characteristics table are guaranteed. Other parametric values quoted in this data sheet are provided for guidance.*

# Mouser Electronics

Authorized Distributor

Click to View Pricing, Inventory, Delivery & Lifecycle Information:

[MAX3522CTN+](#)