1. Overview

1.1 Features

The R8C/LA3A Group, R8C/LA5A Group, R8C/LA6A Group, and R8C/LA8A Group of single-chip MCUs incorporate the R8C CPU core, which implements a powerful instruction set for a high level of efficiency and supports a 1 Mbyte address space, allowing execution of instructions at high speed. In addition, the CPU core integrates a multiplier for high-speed operation processing.

Power consumption is low, and the supported operating modes allow additional power control. These MCUs are designed to maximize EMI/EMS performance.

Integration of many peripheral functions, including multifunction timer and serial interface, helps reduce the number of system components.

The R8C/LA3A Group, R8C/LA5A Group, R8C/LA6A Group, and R8C/LA8A Group have data flash.

1.1.1 Applications

Household appliances, office equipment, audio equipment, consumer products, etc.

1.1.2 Differences between Groups

Table 1.1 lists the Differences between Groups, Tables 1.2 and 1.3 list the Programmable I/O Ports Provided for Each Group, and Tables 1.4 and 1.5 list the LCD Display Function Pins Provided for Each Group.

Figures 1.9 to 1.12 show the pin assignment for each group, and Tables 1.9 to 1.12 list product information.

The explanations in the chapters which follow apply to the R8C/LA8A Group only. Note the differences shown below.

Table 1.1 Differences between Groups

Item	Function	R8C/LA3A Group	R8C/LA5A Group	R8C/LA6A Group	R8C/LA8A Group
I/O Ports	Programmable I/O ports	26 pins	44 pins	56 pins	72 pins
	High current drive ports	8 pins	8 pins	8 pins	10 pins
Interrupts	$\overline{\text{INT}}$ interrupt pins	5 pins	6 pins	8 pins	8 pins
Timer RJ	Timer RJ0 output pin	None	None	None	1 pin
	Timer RJ1 output pin	None	None	None	1 pin
	Timer RJ2 I/O pin	None	None	None	1 pin
	Timer RJ2 output pin	None	None	None	1 pin
Timer RH	Timer RH output pin	None	1 pin	1 pin	1 pin
Serial interface	UART2	None	None	1 pin	1 pin
A/D Converter	Analog input pins	5 pins	7 pins	8 pins	12 pins
LCD Drive Control Circuit	Segment output pins	Max. 11 pins	Max. 27 pins	Max. 32 pins	Max. 40 pins
Comparator B	Analog input voltage	1 pin	2 pins	2 pins	2 pins
	Reference input voltage	1 pin	2 pins	2 pins	2 pins
Clock	XCIN pin	Shared with XIN pin	Dedicated pin	Dedicated pin	Dedicated pin
	XCOUT pin	Shared with XOUT pin	Dedicated pin	Dedicated pin	Dedicated pin
Packages		32-pin LQFP	52-pin LQFP	64-pin LQFP	80-pin LQFP

Note:

- I/O ports are shared with I/O functions, such as interrupts or timers. Refer to Tables 1.13 to 1.17, Pin Name Information by Pin Number, for details.

Table 1.2 Programmable I/O Ports Provided for Each Group (R8C/LA3A Group, R8C/LA5A Group)

Programmable I/O Port	R8C/LA3A Group Total: 26 I/O pins								R8C/LA5A Group Total: 44 I/O pins							
	Bit 7	Bit 6	Bit 5	Bit 4	Bit 3	Bit 2	Bit 1	Bit 0	Bit 7	Bit 6	Bit 5	Bit 4	Bit 3	Bit 2	Bit 1	Bit 0
P0	—	—	—	—	—	—	—	—	✓	✓	✓	✓	✓	✓	✓	✓
P2	✓	✓	✓	✓	✓	✓	✓	✓	✓	✓	✓	✓	✓	✓	✓	✓
P3	—	—	—	—	—	—	—	—	✓	✓	✓	✓	✓	✓	✓	✓
P5	—	✓	✓	✓	✓	✓	✓	✓	—	✓	✓	✓	✓	✓	✓	✓
P7	—	—	—	—	—	—	✓	—	—	—	—	—	—	✓	✓	✓
P8	✓	✓	✓	✓	✓	✓	✓	✓	✓	✓	✓	✓	✓	✓	✓	✓
P9	—	—	—	—	—	—	✓	✓	—	—	—	—	—	—	✓	✓

Notes:

1. The symbol “✓” indicates a programmable I/O port.
2. The symbol “—” indicates the settings should be made as follows:
 - Set 0 to the corresponding bits in the PDi (i = 0, 3, 5, 7, 9) register. When read, the content is 0.
 - Set 0 to the corresponding bits in the Pi (i = 0, 3, 5, 7, 9) register. When read, the content is 0.

Table 1.3 Programmable I/O Ports Provided for Each Group (R8C/LA6A Group, R8C/LA8A Group)

Programmable I/O Port	R8C/LA6A Group Total: 56 I/O pins								R8C/LA8A Group Total: 72 I/O pins							
	Bit 7	Bit 6	Bit 5	Bit 4	Bit 3	Bit 2	Bit 1	Bit 0	Bit 7	Bit 6	Bit 5	Bit 4	Bit 3	Bit 2	Bit 1	Bit 0
P0	✓	✓	✓	✓	✓	✓	✓	✓	✓	✓	✓	✓	✓	✓	✓	✓
P1	✓	✓	✓	✓	✓	✓	—	—	✓	✓	✓	✓	✓	✓	✓	✓
P2	✓	✓	✓	✓	✓	✓	✓	✓	✓	✓	✓	✓	✓	✓	✓	✓
P3	✓	✓	✓	✓	✓	✓	✓	✓	✓	✓	✓	✓	✓	✓	✓	✓
P4	✓	✓	—	—	—	—	—	—	✓	✓	✓	✓	✓	✓	✓	✓
P5	—	✓	✓	✓	✓	✓	✓	✓	—	✓	✓	✓	✓	✓	✓	✓
P6	✓	✓	✓	✓	✓	✓	✓	—	✓	✓	✓	✓	✓	✓	✓	✓
P7	—	—	—	—	—	—	—	—	—	✓	✓	✓	✓	✓	✓	✓
P8	✓	✓	✓	✓	✓	✓	✓	✓	✓	✓	✓	✓	✓	✓	✓	✓
P9	—	—	—	—	—	—	✓	✓	—	—	—	—	—	—	✓	✓

Notes:

1. The symbol “✓” indicates a programmable I/O port.
2. The symbol “—” indicates the settings should be made as follows:
 - Set 0 to the corresponding bits in the PDi (i = 1, 4 to 7, 9) register. When read, the content is 0.
 - Set 0 to the corresponding bits in the Pi (i = 1, 4 to 7, 9) register. When read, the content is 0.
 - Set 0 to the corresponding bits in the P7DRR register. When read, the content is 0.

**Table 1.4 LCD Display Function Pins Provided for Each Group
(R8C/LA3A Group, R8C/LA5A Group)**

Shared I/O Port	R8C/LA3A Group Common output: Max. 4 Segment output: Max. 11								R8C/LA5A Group Common output: Max. 4 Segment output: Max. 27							
	P0	—	—	—	—	—	—	—	—	SEG 7	SEG 6	SEG 5	SEG 4	SEG 3	SEG 2	SEG 1
P2	SEG 15	SEG 14	SEG 13	SEG 12	SEG 11	SEG 10	SEG 9	SEG 8	SEG 15	SEG 14	SEG 13	SEG 12	SEG 11	SEG 10	SEG 9	SEG 8
P3	—	—	—	—	—	—	—	—	SEG 23	SEG 22	SEG 21	SEG 20	SEG 19	SEG 18	SEG 17	SEG 16
P5	—	VL3 (2)	VL2 (2)	VL1 (2)	COM 0	COM 1 SEG 26	COM 2 SEG 25	COM 3 SEG 24	—	VL3 (2)	VL2 (2)	VL1 (2)	COM 0	COM 1 SEG 26	COM 2 SEG 25	COM 3 SEG 24

Notes:

1. The symbol “—” indicates there is no LCD display function. Set the corresponding bits to 0 by setting registers LSE0, LSE2, and LSE5 for these pins.
2. When using the LCD drive control circuit, set the corresponding bit in the LSE5 register to 1.

**Table 1.5 LCD Display Function Pins Provided for Each Group
(R8C/LA6A Group, R8C/LA8A Group)**

Shared I/O Port	R8C/LA6A Group Common output: Max. 4 Segment output: Max. 32								R8C/LA8A Group Common output: Max. 4 Segment output: Max. 40							
	P0	SEG 7	SEG 6	SEG 5	SEG 4	SEG 3	SEG 2	SEG 1	SEG 0	SEG 7	SEG 6	SEG 5	SEG 4	SEG 3	SEG 2	SEG 1
P1	SEG 15	SEG 14	SEG 13	SEG 12	SEG 11	SEG 10	—	—	SEG 15	SEG 14	SEG 13	SEG 12	SEG 11	SEG 10	SEG 9	SEG 8
P2	SEG 23	SEG 22	SEG 21	SEG 20	SEG 19	SEG 18	SEG 17	SEG 16	SEG 23	SEG 22	SEG 21	SEG 20	SEG 19	SEG 18	SEG 17	SEG 16
P3	SEG 31	SEG 30	SEG 29	SEG 28	SEG 27	SEG 26	SEG 25	SEG 24	SEG 31	SEG 30	SEG 29	SEG 28	SEG 27	SEG 26	SEG 25	SEG 24
P4	SEG 39	SEG 38	—	—	—	—	—	—	SEG 39	SEG 38	SEG 37	SEG 36	SEG 35	SEG 34	SEG 33	SEG 32
P5	—	VL3 (2)	VL2 (2)	VL1 (2)	COM 0	COM 1	COM 2	COM 3	—	VL3 (2)	VL2 (2)	VL1 (2)	COM 0	COM 1	COM 2	COM 3

Notes:

1. The symbol “—” indicates there is no LCD display function. Set the corresponding bits to 0 by setting registers LSE1, LSE4 and LSE5 for these pins.
2. When using the LCD drive control circuit, set the corresponding bit in the LSE5 register to 1.

1.1.3 Specifications

Tables 1.6 to 1.8 list the specifications.

Table 1.6 Specifications (1)

Item	Function	Specification
CPU	Central processing unit	R8C CPU core <ul style="list-style-type: none"> • Number of fundamental instructions: 89 • Minimum instruction execution time: 50 ns ($f(XIN) = 20$ MHz, $VCC = 2.7$ V to 5.5 V) 125 ns ($f(XIN) = 8$ MHz, $VCC = 1.8$ V to 5.5 V) • Multiplier: 16 bits \times 16 bits \rightarrow 32 bits • Multiply-accumulate instruction: 16 bits \times 16 bits + 32 bits \rightarrow 32 bits • Operating mode: Single-chip mode (address space: 1 Mbyte)
Memory	ROM/RAM Data flash	Refer to Tables 1.9 to 1.12 Product Lists.
Power Supply Voltage Detection	Voltage detection circuit	<ul style="list-style-type: none"> • Power-on reset • Voltage detection 3 (detection level of voltage detection 0 and voltage detection 1 selectable)
I/O Ports	Programmable I/O ports	R8C/LA3A Group <ul style="list-style-type: none"> • CMOS I/O ports: 26, selectable pull-up resistor ⁽¹⁾ • High current drive ports: 8
		R8C/LA5A Group <ul style="list-style-type: none"> • CMOS I/O ports: 44, selectable pull-up resistor ⁽¹⁾ • High current drive ports: 8
		R8C/LA6A Group <ul style="list-style-type: none"> • CMOS I/O ports: 56, selectable pull-up resistor ⁽¹⁾ • High current drive ports: 8
		R8C/LA8A Group <ul style="list-style-type: none"> • CMOS I/O ports: 72, selectable pull-up resistor ⁽¹⁾ • High current drive ports: 10
Clock	Clock generation circuits	4 circuits: XIN clock oscillation circuit XCIN clock oscillation circuit (32 kHz) High-speed on-chip oscillator (with frequency adjustment function) Low-speed on-chip oscillator <ul style="list-style-type: none"> • Oscillation stop detection: XIN clock oscillation stop detection function • Frequency divider circuit: Division ratio selectable from 1, 2, 4, 8, and 16 • Low-power-consumption modes: Standard operating mode (high-speed clock, low-speed clock, high-speed on-chip oscillator, low-speed on-chip oscillator), wait mode, stop mode, power-off mode
		Real-time clock (timer RH)
Interrupts	R8C/LA3A Group	<ul style="list-style-type: none"> • Number of interrupt vectors: 69 • External Interrupt: 13 ($\overline{INT} \times 5$, key input $\times 8$) • Priority levels: 7 levels
	R8C/LA5A Group	<ul style="list-style-type: none"> • Number of interrupt vectors: 69 • External Interrupt: 14 ($\overline{INT} \times 6$, key input $\times 8$) • Priority levels: 7 levels
	R8C/LA6A Group	<ul style="list-style-type: none"> • Number of interrupt vectors: 69
	R8C/LA8A Group	<ul style="list-style-type: none"> • External Interrupt: 16 ($\overline{INT} \times 8$, key input $\times 8$) • Priority levels: 7 levels
Watchdog Timer		<ul style="list-style-type: none"> • 14 bits \times 1 (with prescaler) • Selectable reset start function • Selectable low-speed on-chip oscillator for watchdog timer

Note:

1. No pull-up resistor is provided in the pins P5_4 to P5_6.

Table 1.7 Specifications (2)

Item	Function	Specification		
Timer	Timer RB0, Timer RB1	8 bits × 2 (with 8-bit prescaler) Timer mode (period timer), programmable waveform generation mode (PWM output), programmable one-shot generation mode, programmable wait one-shot generation mode		
	Timer RC	16 bits × 1 (with 4 capture/compare registers) Timer mode (input capture function, output compare function), PWM mode (output: 3 pins), PWM2 mode (PWM output: 1 pin)		
	Timer RH	Real-time clock mode (counting of seconds, minutes, hours, day of the week, date, month, year), output compare mode		
	Timer RJ0 Timer RJ1 Timer RJ2	R8C/LA3A Group R8C/LA5A Group R8C/LA6A Group R8C/LA8A Group	Timer RJ0, Timer RJ1 Timer RJ0, Timer RJ1, Timer RJ2	16 bits × 2 16 bits × 3
Serial Interface	UART0	1 channel Clock synchronous serial I/O/UART		
	UART2	1 channel Clock synchronous serial I/O/UART, I ² C mode (I ² C-bus), multiprocessor communication function		
Synchronous Serial Communication Unit (SSU)		1 (shared with I ² C-bus)		
I ² C bus		1 (shared with SSU)		
A/D Converter	R8C/LA3A Group	10-bit resolution × 5 channels, including sample and hold function, with sweep mode, temperature sensor included (measurement temperature range: –20 to 85 °C (N version)/ –40 to 85 °C (D version))		
	R8C/LA5A Group	10-bit resolution × 7 channels, including sample and hold function, with sweep mode, temperature sensor included (measurement temperature range: –20 to 85 °C (N version)/ –40 to 85 °C (D version))		
	R8C/LA6A Group	10-bit resolution × 8 channels, including sample and hold function, with sweep mode, temperature sensor included (measurement temperature range: –20 to 85 °C (N version)/ –40 to 85 °C (D version))		
	R8C/LA8A Group	10-bit resolution × 12 channels, including sample and hold function, with sweep mode, temperature sensor included (measurement temperature range: –20 to 85 °C (N version)/ –40 to 85 °C (D version))		
Comparator B	R8C/LA3A Group	1 circuit (comparator B1)		
	R8C/LA5A Group	2 circuits (comparator B1, comparator B3)		
	R8C/LA6A Group			
	R8C/LA8A Group			

Table 1.8 Specifications (3)

Item	Function	Specification
LCD Drive Control Circuit	R8C/LA3A Group	Common output: Max. 4 pins Segment output: Max. 11 pins
	R8C/LA5A Group	Common output: Max. 4 pins Segment output: Max. 27 pins
	R8C/LA6A Group	Common output: Max. 4 pins Segment output: Max. 32 pins
	R8C/LA8A Group	Common output: Max. 4 pins Segment output: Max. 40 pins
		<ul style="list-style-type: none"> • Bias: 1/2, 1/3 • Duty: static, 1/2, 1/3, 1/4
Flash Memory		<ul style="list-style-type: none"> • Programming and erasure voltage: VCC = 1.8 V to 5.5 V (data flash VCC = 1.8 V to 5.5 V) • Programming and erasure endurance: 10,000 times (data flash) 10,000 times (program ROM) • Program security: ROM code protect, ID code check • On-chip debug function • On-board flash rewrite function
Operating Frequency/ Supply Voltage		f(XIN) = 20 MHz (VCC = 2.7 V to 5.5 V) f(XIN) = 8 MHz (VCC = 1.8 V to 5.5 V)
Current Consumption		Typ. 4.7 mA (VCC = 5.0 V, f(XIN) = 20 MHz) Typ. 2.3 mA (VCC = 3.0 V, f(XIN) = 10 MHz) Typ. 1.7 μ A (VCC = 3.0 V, wait mode (f(XCIN) = 32 kHz)) Typ. 0.5 μ A (VCC = 3.0 V, stop mode) Typ. 1.3 μ A (VCC = 3.0 V, power-off 2 mode, timer RH enabled) Typ. 0.01 μ A (VCC = 3.0 V, power-off 0 mode, timer RH disabled)
Operating Ambient Temperature		-20 to 85°C (N version) -40 to 85°C (D version) (1)

Note:

1. Specify the D version if D version functions are to be used.

1.2 Product Lists

Tables 1.9 to 1.12 list product information for each group. Figures 1.1 to 1.4 show the Correspondence of Part No., with Memory Size and Package for each group.

Table 1.9 Product List for R8C/LA3A Group **Current of Oct 2011**

Part No.	Internal ROM Capacity		Internal RAM Capacity	Package Type	Remarks
	Program ROM	Data Flash			
R5F2LA32ANFP	8 Kbytes	1 Kbyte × 2	2 Kbytes	PLQP0032GB-A	N Version
R5F2LA34ANFP	16 Kbytes	1 Kbyte × 2	2 Kbytes	PLQP0032GB-A	
R5F2LA36ANFP	32 Kbytes	1 Kbyte × 2	2 Kbytes	PLQP0032GB-A	
R5F2LA38ANFP	64 Kbytes	1 Kbyte × 2	3.5 Kbytes	PLQP0032GB-A	
R5F2LA32ADFP	8 Kbytes	1 Kbyte × 2	2 Kbytes	PLQP0032GB-A	D Version
R5F2LA34ADFP	16 Kbytes	1 Kbyte × 2	2 Kbytes	PLQP0032GB-A	
R5F2LA36ADFP	32 Kbytes	1 Kbyte × 2	2 Kbytes	PLQP0032GB-A	
R5F2LA38ADFP	64 Kbytes	1 Kbyte × 2	3.5 Kbytes	PLQP0032GB-A	

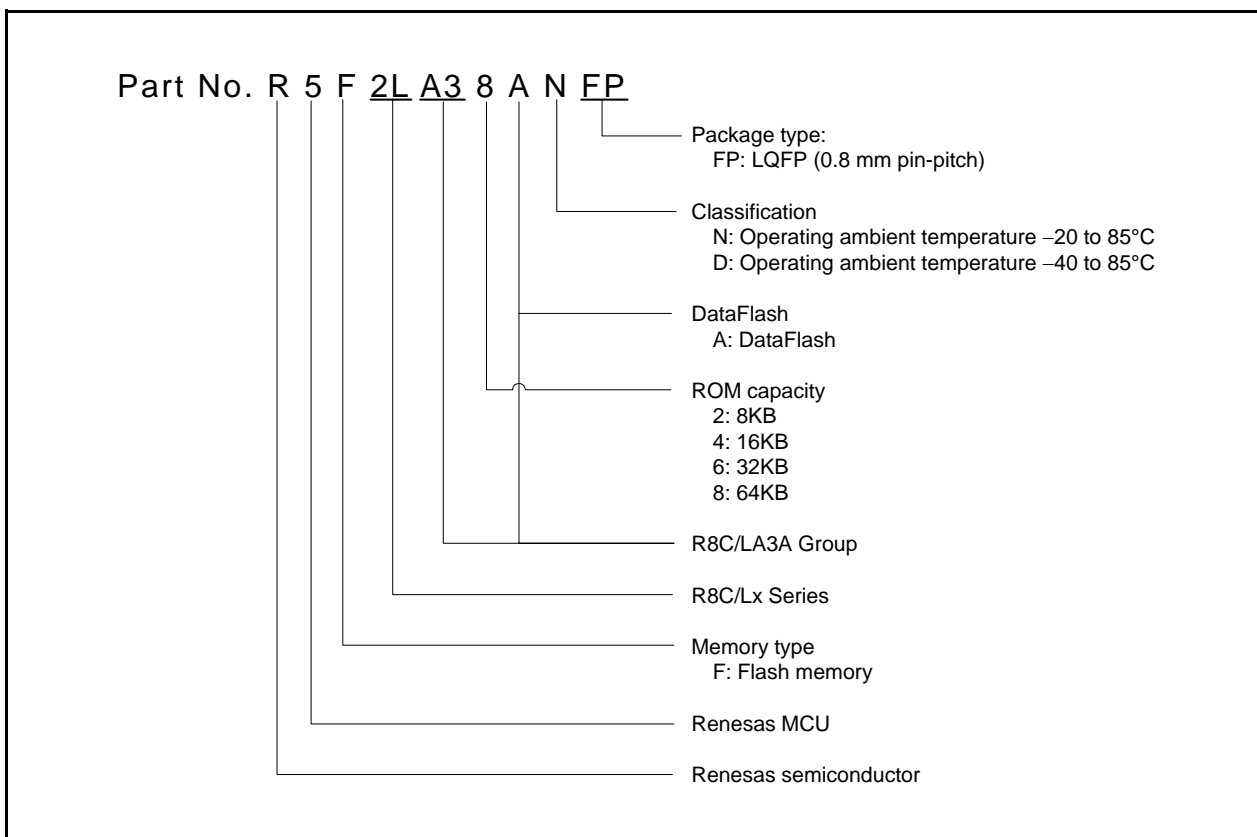

Figure 1.1 Correspondence of Part No., with Memory Size and Package of R8C/LA3A Group

Table 1.10 Product List for R8C/LA5A Group

Current of Oct 2011

Part No.	Internal ROM Capacity		Internal RAM Capacity	Package Type	Remarks
	Program ROM	Data Flash			
R5F2LA52ANFP	8 Kbytes	1 Kbyte × 2	2 Kbytes	PLQP0052JA-A	N Version
R5F2LA54ANFP	16 Kbytes	1 Kbyte × 2	2 Kbytes	PLQP0052JA-A	
R5F2LA56ANFP	32 Kbytes	1 Kbyte × 2	2 Kbytes	PLQP0052JA-A	
R5F2LA58ANFP	64 Kbytes	1 Kbyte × 2	3.5 Kbytes	PLQP0052JA-A	
R5F2LA52ADFP	8 Kbytes	1 Kbyte × 2	2 Kbytes	PLQP0052JA-A	D Version
R5F2LA54ADFP	16 Kbytes	1 Kbyte × 2	2 Kbytes	PLQP0052JA-A	
R5F2LA56ADFP	32 Kbytes	1 Kbyte × 2	2 Kbytes	PLQP0052JA-A	
R5F2LA58ADFP	64 Kbytes	1 Kbyte × 2	3.5 Kbytes	PLQP0052JA-A	

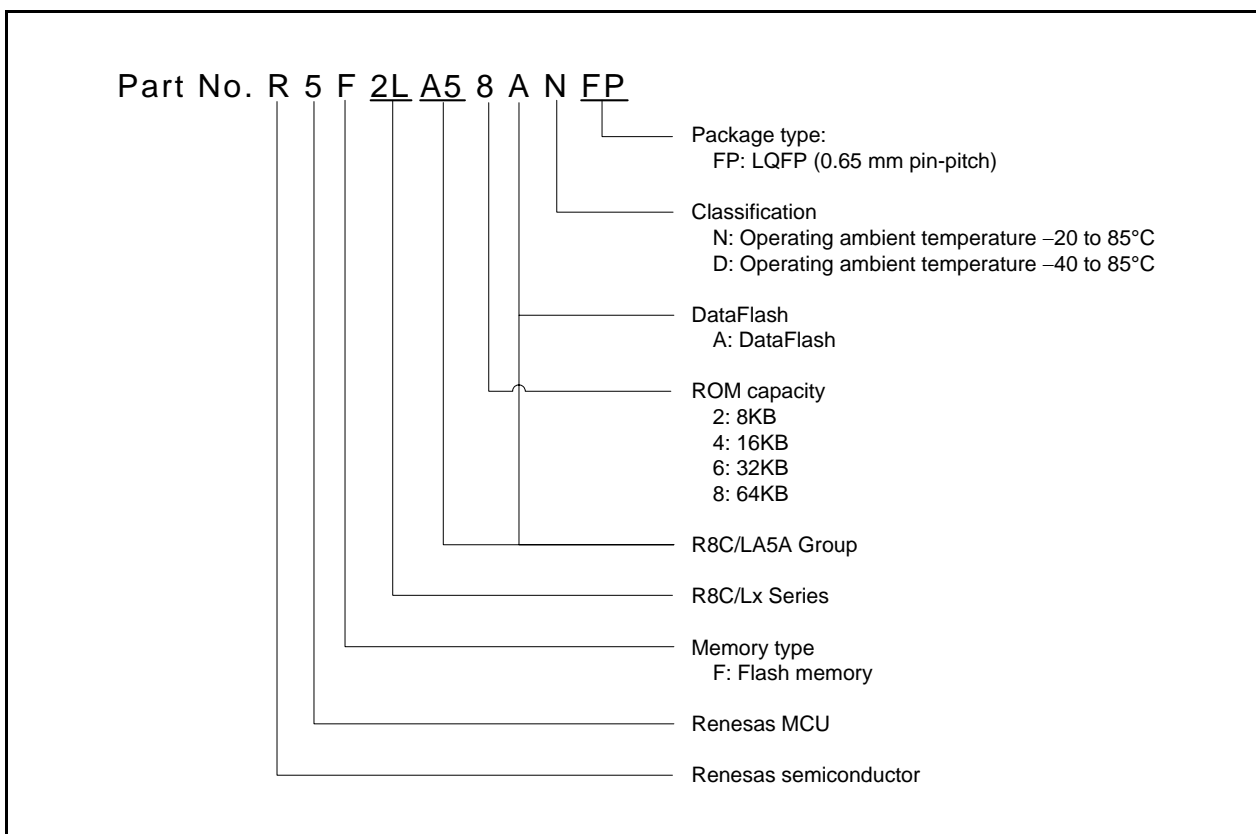

Figure 1.2 Correspondence of Part No., with Memory Size and Package of R8C/LA5A Group

Table 1.11 Product List for R8C/LA6A Group

Current of Oct 2011

Part No.	Internal ROM Capacity		Internal RAM Capacity	Package Type	Remarks
	Program ROM	Data Flash			
R5F2LA64ANFP	16 Kbytes	1 Kbyte × 2	2 Kbytes	PLQP0064KB-A	N Version
R5F2LA64ANFA	16 Kbytes	1 Kbyte × 2	2 Kbytes	PLQP0064GA-A	
R5F2LA66ANFP	32 Kbytes	1 Kbyte × 2	2 Kbytes	PLQP0064KB-A	
R5F2LA66ANFA	32 Kbytes	1 Kbyte × 2	2 Kbytes	PLQP0064GA-A	
R5F2LA67ANFP	48 Kbytes	1 Kbyte × 2	3.5 Kbytes	PLQP0064KB-A	
R5F2LA67ANFA	48 Kbytes	1 Kbyte × 2	3.5 Kbytes	PLQP0064GA-A	
R5F2LA68ANFP	64 Kbytes	1 Kbyte × 2	3.5 Kbytes	PLQP0064KB-A	
R5F2LA68ANFA	64 Kbytes	1 Kbyte × 2	3.5 Kbytes	PLQP0064GA-A	
R5F2LA6AANFP	96 Kbytes	2 Kbytes × 2	5.5 Kbytes	PLQP0064KB-A	
R5F2LA6AANFA	96 Kbytes	2 Kbytes × 2	5.5 Kbytes	PLQP0064GA-A	
R5F2LA6CANFP	128 Kbytes	2 Kbytes × 2	5.5 Kbytes	PLQP0064KB-A	
R5F2LA6CANFA	128 Kbytes	2 Kbytes × 2	5.5 Kbytes	PLQP0064GA-A	
R5F2LA64ADFP	16 Kbytes	1 Kbyte × 2	2 Kbytes	PLQP0064KB-A	D Version
R5F2LA64ADFA	16 Kbytes	1 Kbyte × 2	2 Kbytes	PLQP0064GA-A	
R5F2LA66ADFP	32 Kbytes	1 Kbyte × 2	2 Kbytes	PLQP0064KB-A	
R5F2LA66ADFA	32 Kbytes	1 Kbyte × 2	2 Kbytes	PLQP0064GA-A	
R5F2LA67ADFP	48 Kbytes	1 Kbyte × 2	3.5 Kbytes	PLQP0064KB-A	
R5F2LA67ADFA	48 Kbytes	1 Kbyte × 2	3.5 Kbytes	PLQP0064GA-A	
R5F2LA68ADFP	64 Kbytes	1 Kbyte × 2	3.5 Kbytes	PLQP0064KB-A	
R5F2LA68ADFA	64 Kbytes	1 Kbyte × 2	3.5 Kbytes	PLQP0064GA-A	
R5F2LA6AADFP	96 Kbytes	2 Kbytes × 2	5.5 Kbytes	PLQP0064KB-A	
R5F2LA6AADFA	96 Kbytes	2 Kbytes × 2	5.5 Kbytes	PLQP0064GA-A	
R5F2LA6CADFP	128 Kbytes	2 Kbytes × 2	5.5 Kbytes	PLQP0064KB-A	
R5F2LA6CADFA	128 Kbytes	2 Kbytes × 2	5.5 Kbytes	PLQP0064GA-A	

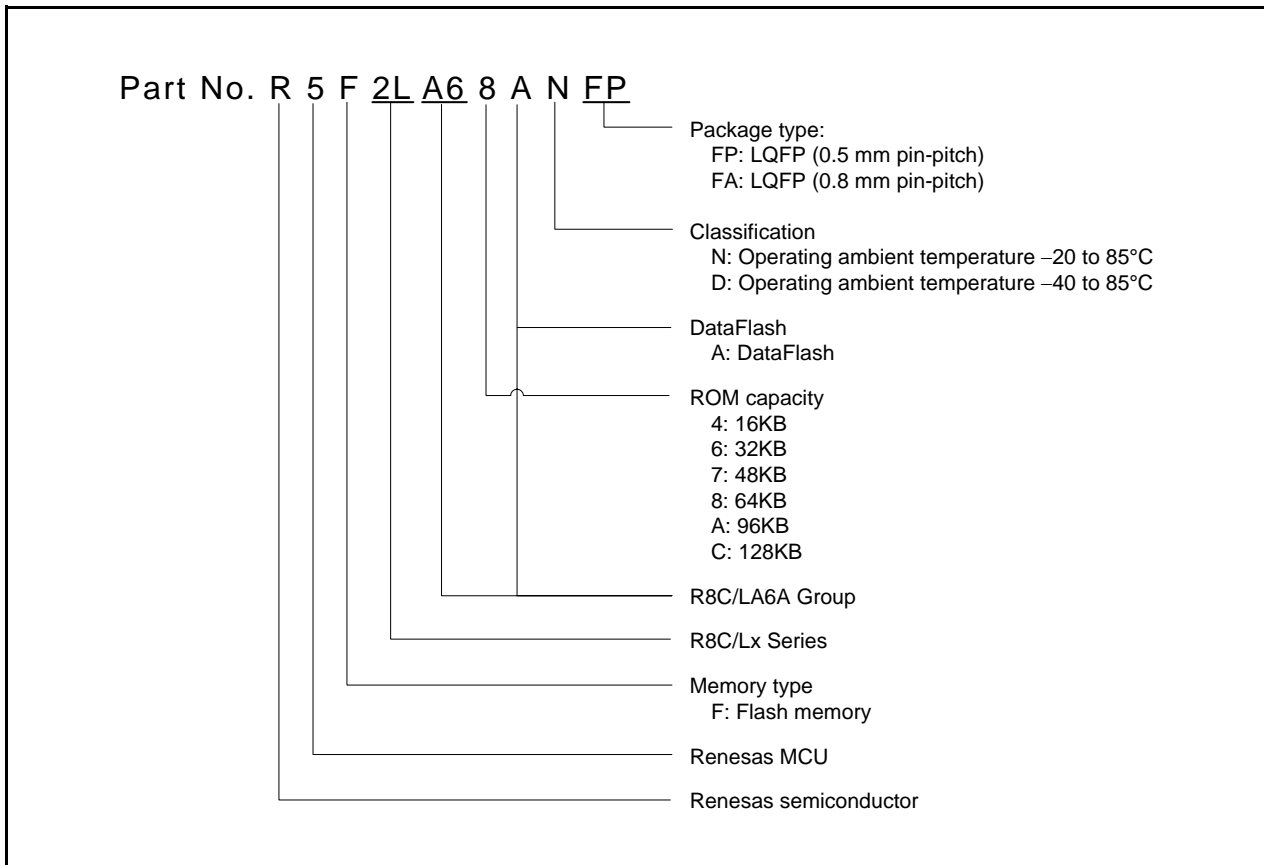

Figure 1.3 Correspondence of Part No., with Memory Size and Package of R8C/LA6A Group

Table 1.12 Product List for R8C/LA8A Group

Current of Oct 2011

Part No.	Internal ROM Capacity		Internal RAM Capacity	Package Type	Remarks
	Program ROM	Data Flash			
R5F2LA84ANFP	16 Kbytes	1 Kbyte × 2	2 Kbytes	PLQP0080KB-A	N Version
R5F2LA84ANFA	16 Kbytes	1 Kbyte × 2	2 Kbytes	PLQP0080JA-A	
R5F2LA86ANFP	32 Kbytes	1 Kbyte × 2	2 Kbytes	PLQP0080KB-A	
R5F2LA86ANFA	32 Kbytes	1 Kbyte × 2	2 Kbytes	PLQP0080JA-A	
R5F2LA87ANFP	48 Kbytes	1 Kbyte × 2	3.5 Kbytes	PLQP0080KB-A	
R5F2LA87ANFA	48 Kbytes	1 Kbyte × 2	3.5 Kbytes	PLQP0080JA-A	
R5F2LA88ANFP	64 Kbytes	1 Kbyte × 2	3.5 Kbytes	PLQP0080KB-A	
R5F2LA88ANFA	64 Kbytes	1 Kbyte × 2	3.5 Kbytes	PLQP0080JA-A	
R5F2LA8AANFP	96 Kbytes	2 Kbytes × 2	5.5 Kbytes	PLQP0080KB-A	
R5F2LA8AANFA	96 Kbytes	2 Kbytes × 2	5.5 Kbytes	PLQP0080JA-A	
R5F2LA8CANFP	128 Kbytes	2 Kbytes × 2	5.5 Kbytes	PLQP0080KB-A	
R5F2LA8CANFA	128 Kbytes	2 Kbytes × 2	5.5 Kbytes	PLQP0080JA-A	
R5F2LA84ADFP	16 Kbytes	1 Kbyte × 2	2 Kbytes	PLQP0080KB-A	D Version
R5F2LA84ADFA	16 Kbytes	1 Kbyte × 2	2 Kbytes	PLQP0080JA-A	
R5F2LA86ADFP	32 Kbytes	1 Kbyte × 2	2 Kbytes	PLQP0080KB-A	
R5F2LA86ADFA	32 Kbytes	1 Kbyte × 2	2 Kbytes	PLQP0080JA-A	
R5F2LA87ADFP	48 Kbytes	1 Kbyte × 2	3.5 Kbytes	PLQP0080KB-A	
R5F2LA87ADFA	48 Kbytes	1 Kbyte × 2	3.5 Kbytes	PLQP0080JA-A	
R5F2LA88ADFP	64 Kbytes	1 Kbyte × 2	3.5 Kbytes	PLQP0080KB-A	
R5F2LA88ADFA	64 Kbytes	1 Kbyte × 2	3.5 Kbytes	PLQP0080JA-A	
R5F2LA8AADFP	96 Kbytes	2 Kbytes × 2	5.5 Kbytes	PLQP0080KB-A	
R5F2LA8AADFA	96 Kbytes	2 Kbytes × 2	5.5 Kbytes	PLQP0080JA-A	
R5F2LA8CADFP	128 Kbytes	2 Kbytes × 2	5.5 Kbytes	PLQP0080KB-A	
R5F2LA8CADFA	128 Kbytes	2 Kbytes × 2	5.5 Kbytes	PLQP0080JA-A	

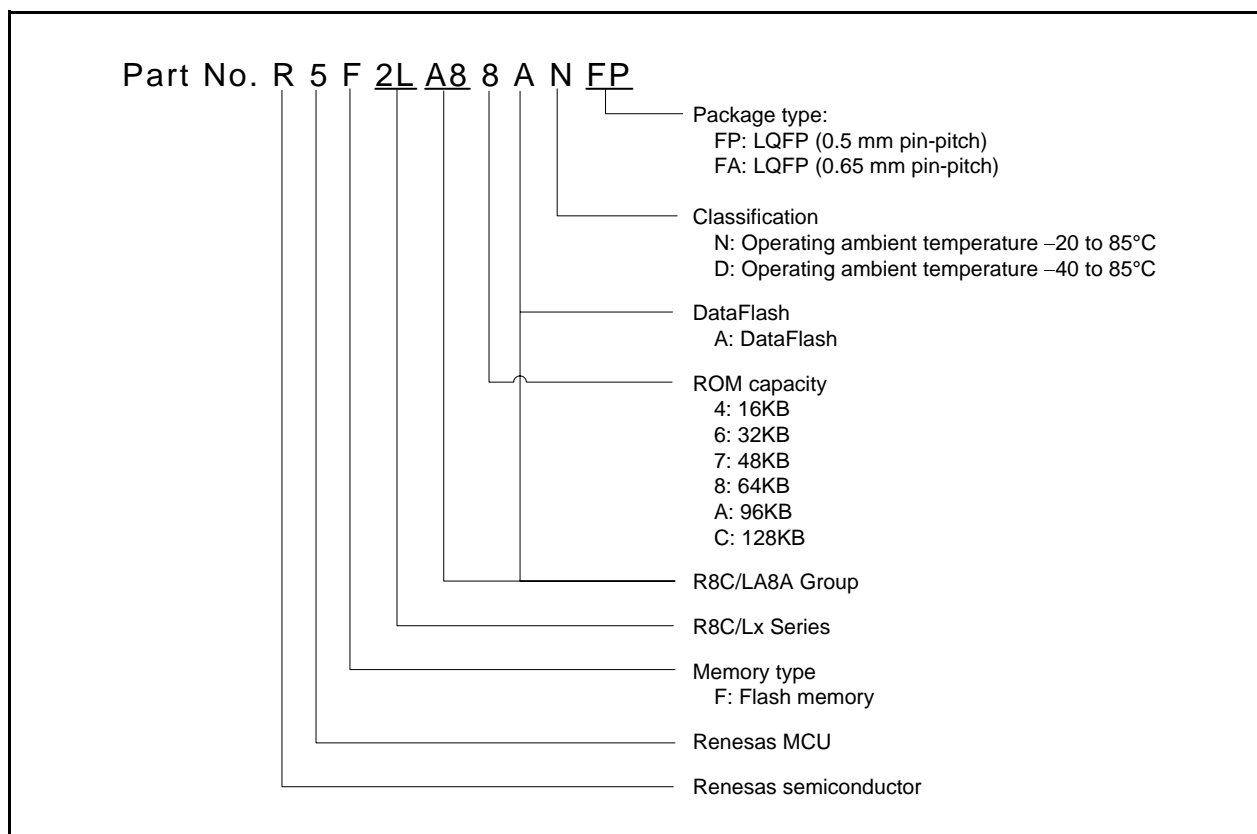

Figure 1.4 Correspondence of Part No., with Memory Size and Package of R8C/LA8A Group

1.3 Block Diagrams

Figure 1.5 shows a Block Diagram of R8C/LA3A Group. Figure 1.6 shows a Block Diagram of R8C/LA5A Group. Figure 1.7 shows a Block Diagram of R8C/LA6A Group. Figure 1.8 shows a Block Diagram of R8C/LA8A Group.

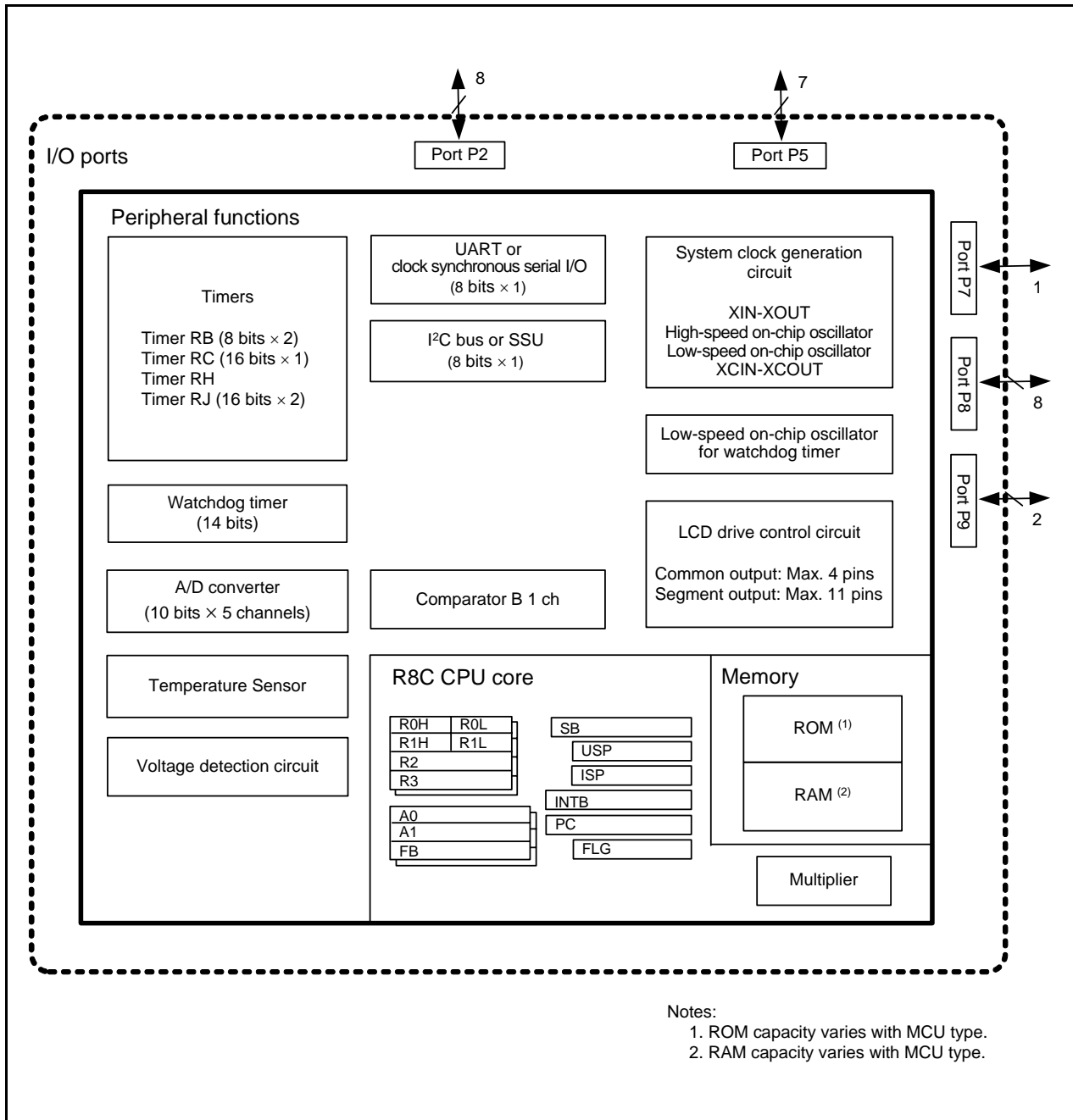

Figure 1.5 Block Diagram of R8C/LA3A Group

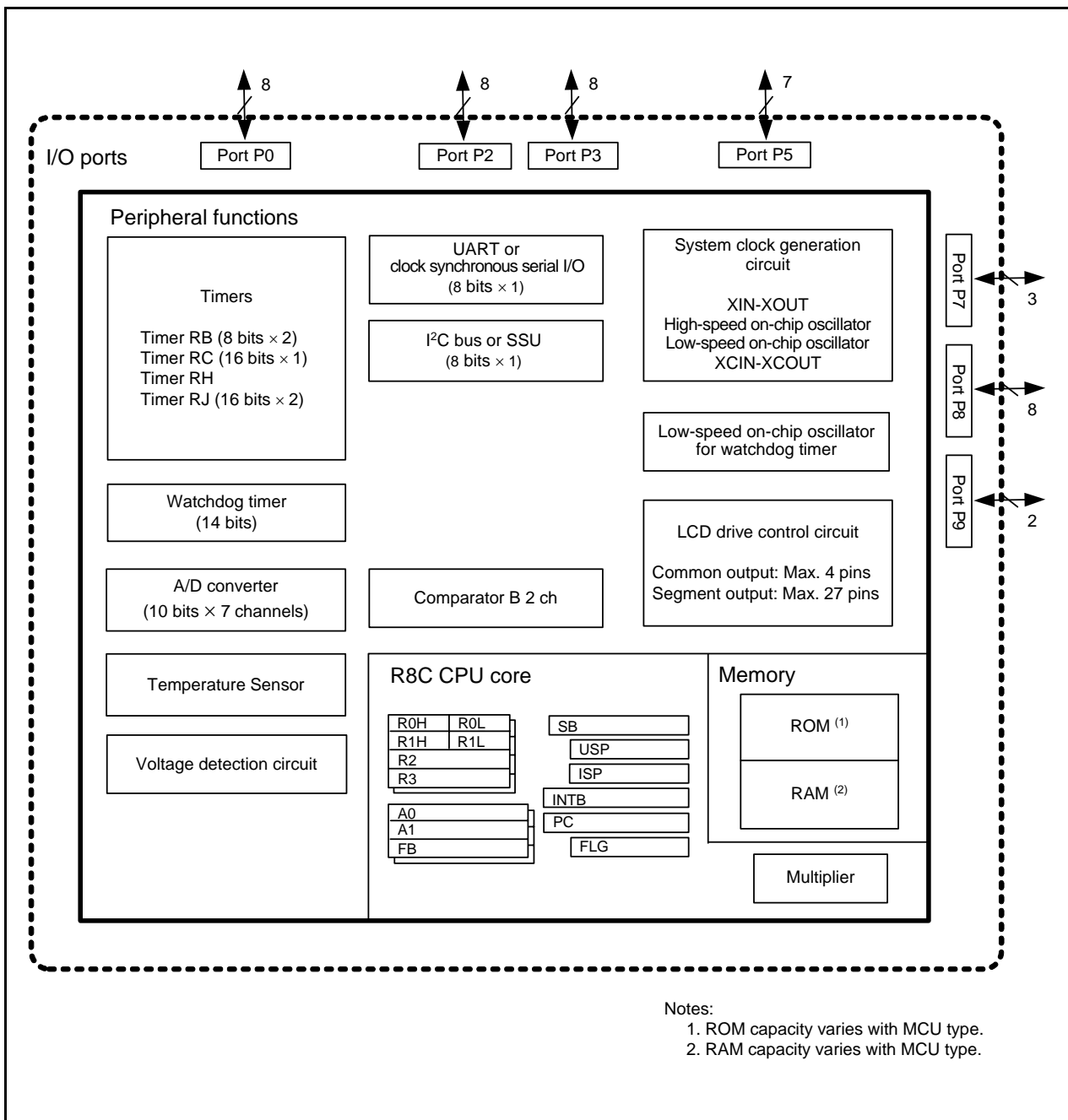

Figure 1.6 Block Diagram of R8C/LA5A Group

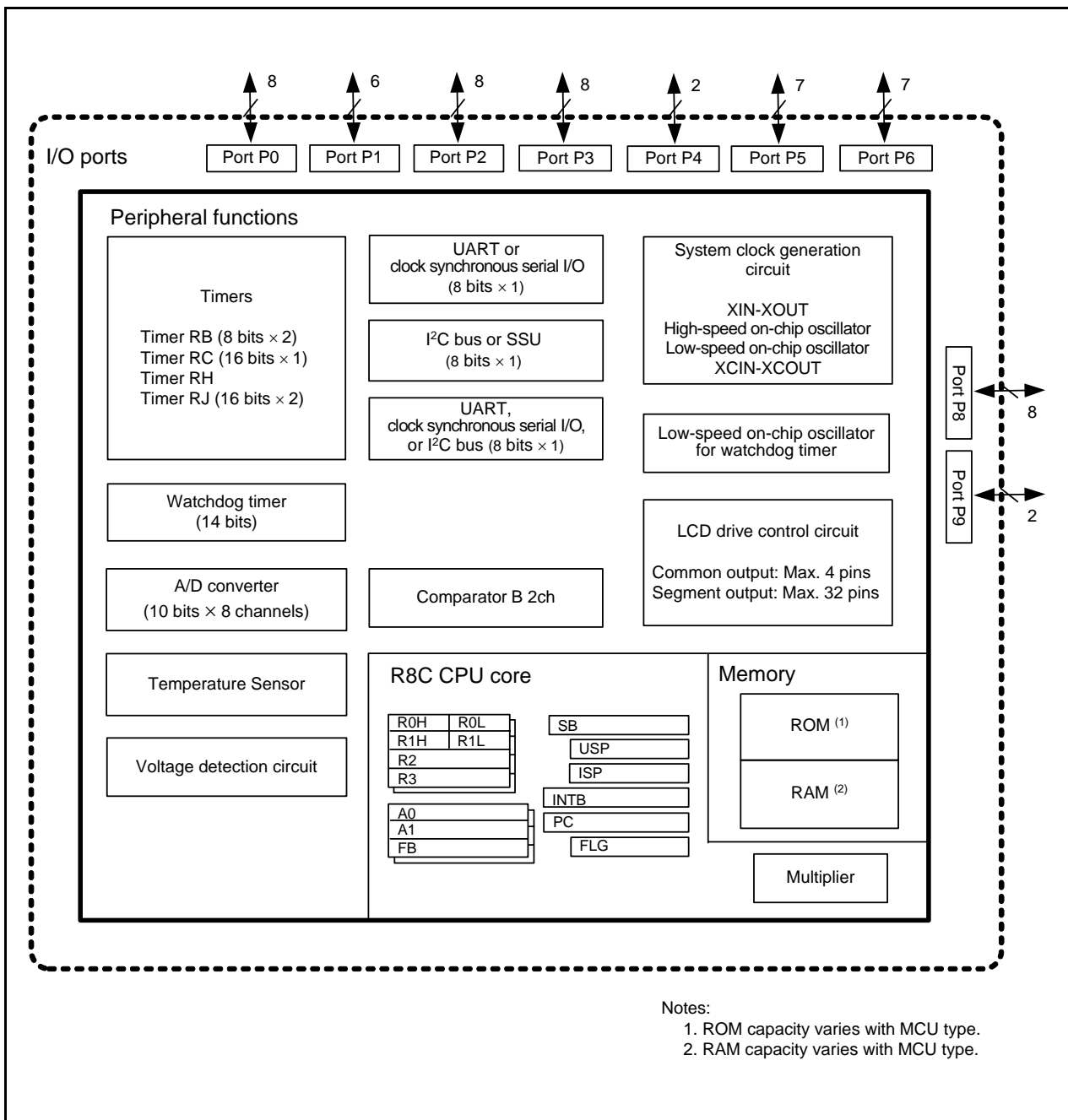

Figure 1.7 Block Diagram of R8C/LA6A Group

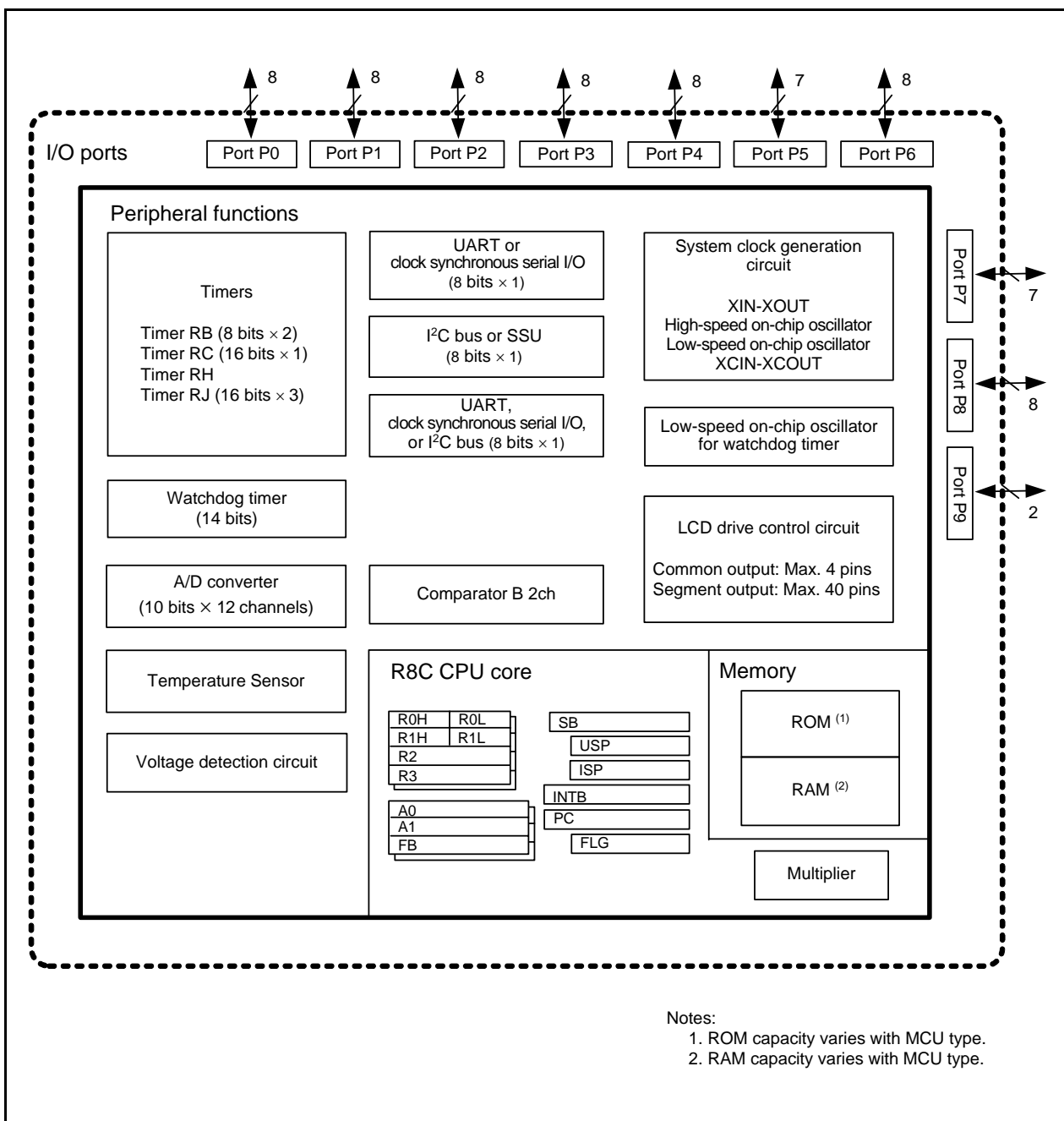

Figure 1.8 Block Diagram of R8C/LA8A Group

1.4 Pin Assignments

Figures 1.9 to 1.12 show pin assignments (top view). Tables 1.13 to 1.17 list the pin name information by pin number.

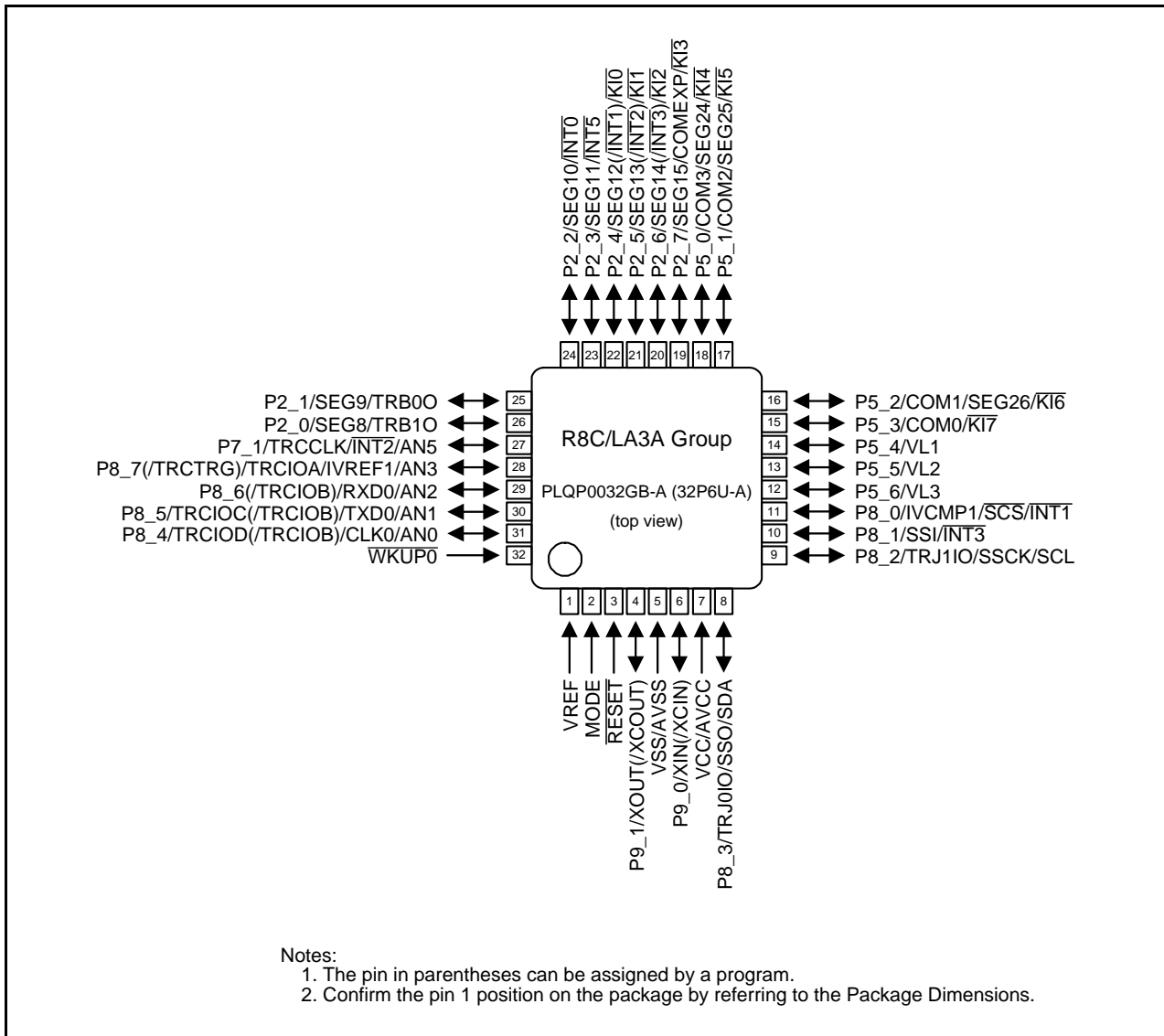

Figure 1.9 Pin Assignment (Top View) of PLQP0032GB-A Package

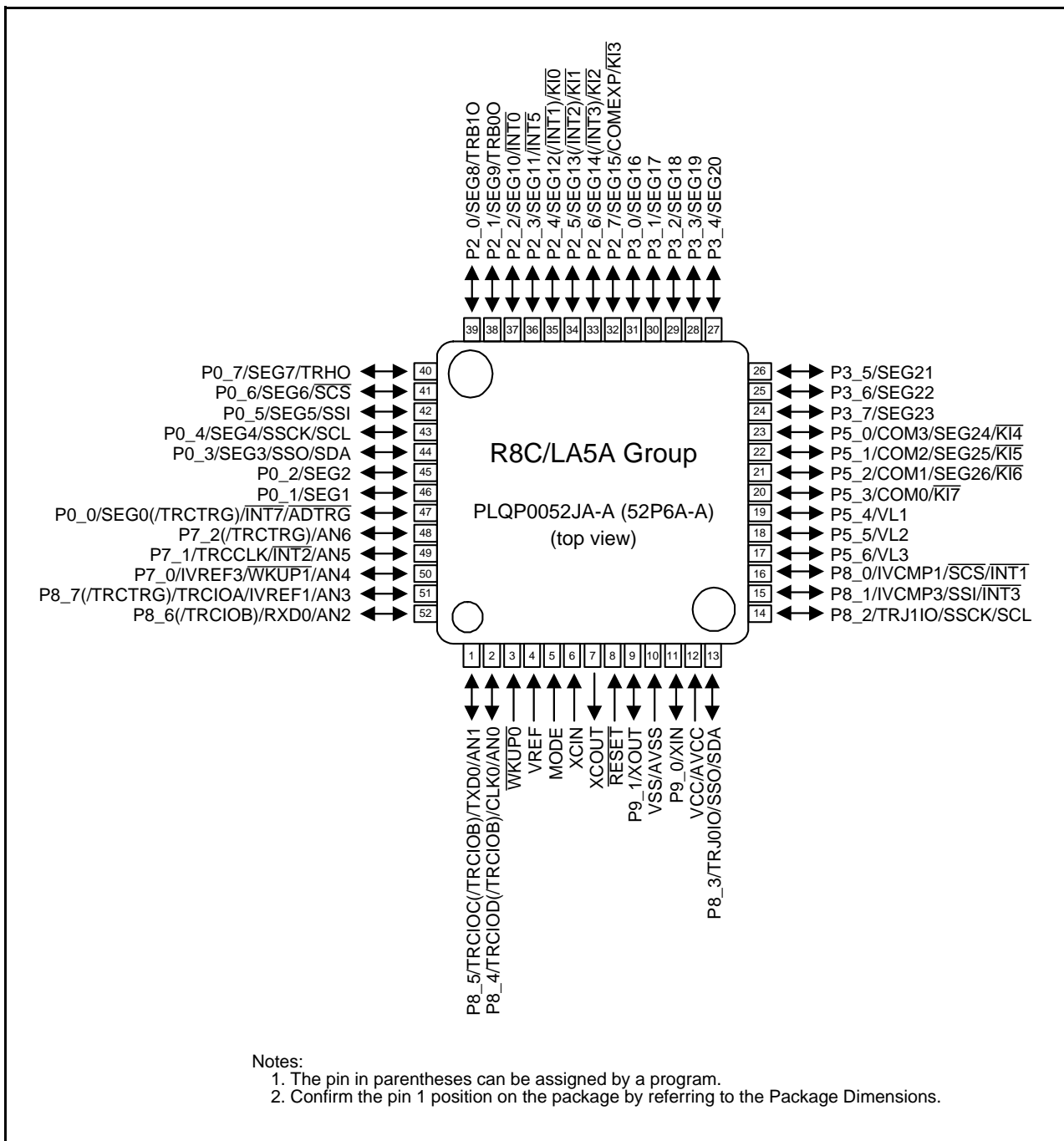

Figure 1.10 Pin Assignment (Top View) of PLQP0052JA-A Package

Table 1.13 Pin Name Information by Pin Number (R8C/LA3A Group, R8C/LA5A Group)(1)

Pin Number		Control Pin	Port	I/O Pin Functions for Peripheral Modules						
LA5A	LA3A			Interrupt	Timer	Serial Interface	SSU	I ² C bus	A/D Converter, Comparator B	LCD drive Control Circuit
1	30		P8_5		TRCIOC/ (TRCIOB)	TXD0			AN1	
2	31		P8_4		TRCIOD/ (TRCIOB)	CLK0			AN0	
3	32	$\overline{WKUP0}$								
4	1	VREF								
5	2	MODE								
6		XCIN								
7		XCOUT								
8	3	\overline{RESET}								
9	4	XOUT (XCOUT) (2)	P9_1							
10	5	VSS/AVSS								
11	6	XIN (XCIN) (2)	P9_0							
12	7	VCC/AVCC								
13	8		P8_3		TRJ0IO		SSO	SDA		
14	9		P8_2		TRJ1IO		SSCK	SCL		
15	10		P8_1	$\overline{INT3}$			SSI		IVCMP3 (3)	
16	11		P8_0	$\overline{INT1}$			\overline{SCS}		IVCMP1	
17	12		P5_6							VL3
18	13		P5_5							VL2
19	14		P5_4							VL1
20	15		P5_3	$\overline{KI7}$						COM0
21	16		P5_2	$\overline{KI6}$						SEG26/ COM1
22	17		P5_1	$\overline{KI5}$						SEG25/ COM2
23	18		P5_0	$\overline{KI4}$						SEG24/ COM3
24			P3_7							SEG23
25			P3_6							SEG22
26			P3_5							SEG21
27			P3_4							SEG20
28			P3_3							SEG19
29			P3_2							SEG18
30			P3_1							SEG17

Note:

1. The pin in parentheses can be assigned by a program.
2. Pins (XCOUT) and (XCIN) are not available in the R8C/LA5A Group.
3. The IVCMP3 pin is not available in the R8C/LA3A Group.

Table 1.14 Pin Name Information by Pin Number (R8C/LA3A Group, R8C/LA5A Group)(2)

Pin Number		Control Pin	Port	I/O Pin Functions for Peripheral Modules						
LA5A	LA3A			Interrupt	Timer	Serial Interface	SSU	I ² C bus	A/D Converter, Comparator B	LCD drive Control Circuit
31			P3_0							SEG16
32	19		P2_7	$\overline{KI3}$						SEG15/ COMEXP
33	20		P2_6	$\overline{(INT3)/KI2}$						SEG14
34	21		P2_5	$\overline{(INT2)/KI1}$						SEG13
35	22		P2_4	$\overline{(INT1)/KI0}$						SEG12
36	23		P2_3	$\overline{INT5}$						SEG11
37	24		P2_2	$\overline{INT0}$						SEG10
38	25		P2_1		TRB00					SEG9
39	26		P2_0		TRB10					SEG8
40			P0_7		TRHO					SEG7
41			P0_6					\overline{SCS}		SEG6
42			P0_5					SSI		SEG5
43			P0_4					SSCK	SCL	SEG4
44			P0_3					SSO	SDA	SEG3
45			P0_2							SEG2
46			P0_1							SEG1
47			P0_0	$\overline{INT7}$	(TRCTRG)				\overline{ADTRG}	SEG0
48			P7_2		(TRCTRG)				AN6	
49	27		P7_1	$\overline{INT2}$	TRCCLK				AN5	
50		$\overline{WKUP1}$	P7_0						AN4/IVREF3	
51	28		P8_7		TRCIOA/ (TRCTRG)				AN3/IVREF1	
52	29		P8_6		(TRCIOB)	RXD0			AN2	

Note:

1. The pin in parentheses can be assigned by a program.

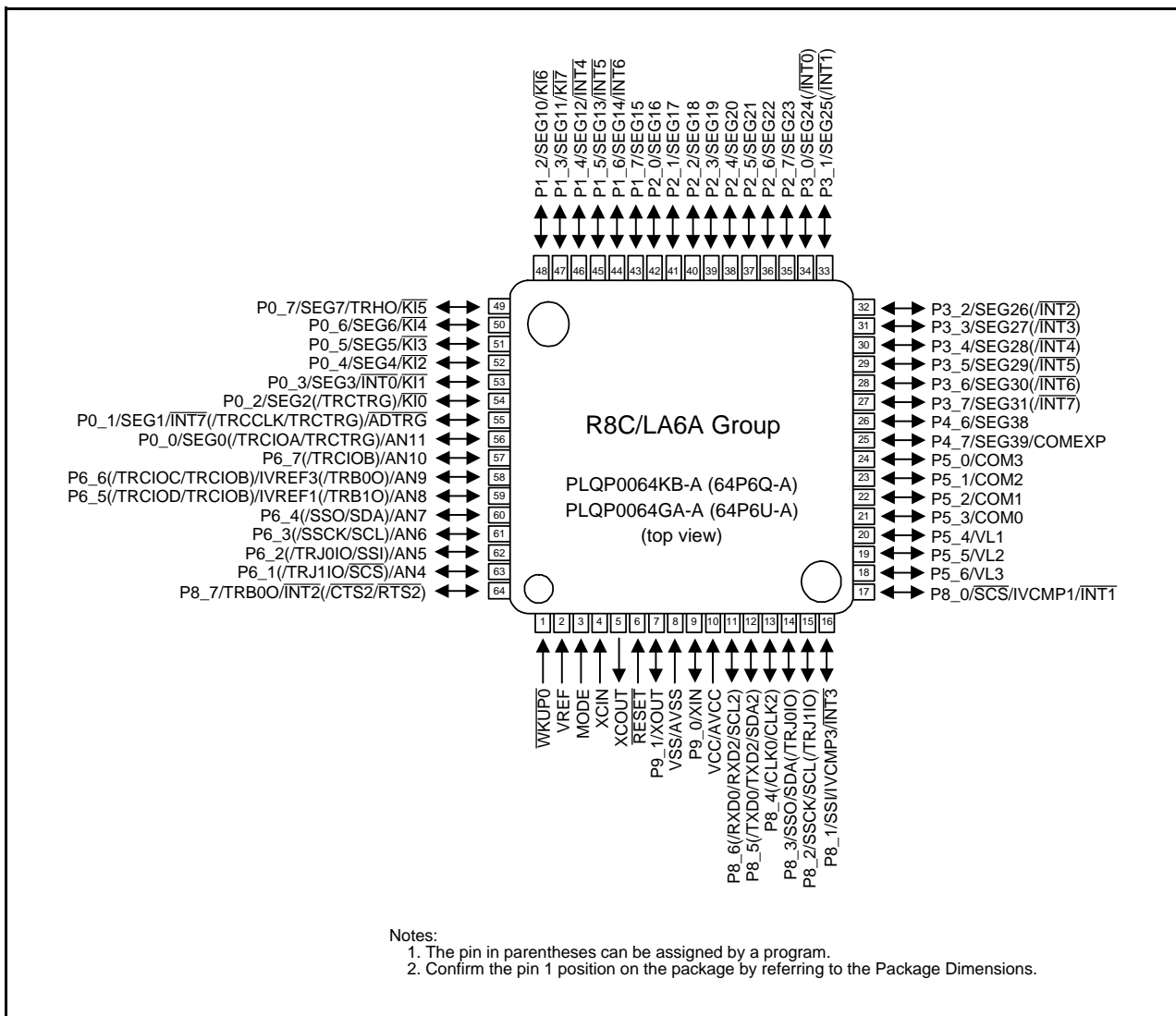

Figure 1.11 Pin Assignment (Top View) of PLQP0064KB-A and PLQP0064GA-A Packages

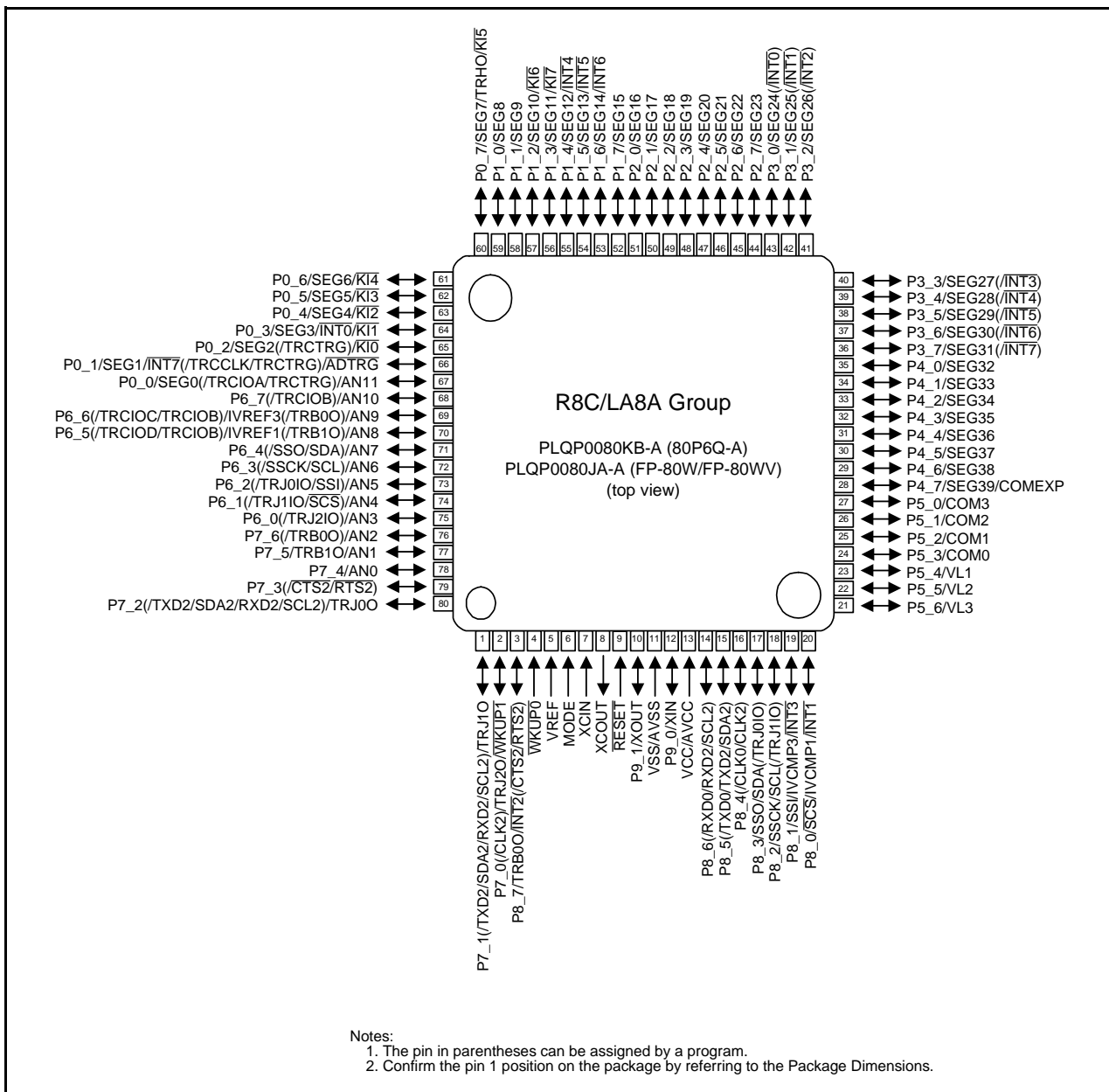

Figure 1.12 Pin Assignment (Top View) of PLQP0080KB-A and PLQP0080JA-A Packages

Table 1.15 Pin Name Information by Pin Number (R8C/LA6A Group, R8C/LA8A Group)(1)

Pin Number		Control Pin	Port	I/O Pin Functions for Peripheral Modules						
LA8A	LA6A			Interrupt	Timer	Serial Interface	SSU	I ² C bus	A/D Converter, Comparator B	LCD drive Control Circuit
1			P7_1		TRJ1O	(TXD2/SDA2/RXD2/SCL2)				
2		$\overline{\text{WKUP1}}$	P7_0		TRJ2O	(CLK2)				
3	64		P8_7	$\overline{\text{INT2}}$	TRB0O	(CTS2/RTS2)				
4	1	$\overline{\text{WKUP0}}$								
5	2	VREF								
6	3	MODE								
7	4	XCIN								
8	5	XCOUT								
9	6	$\overline{\text{RESET}}$								
10	7	XOUT	P9_1							
11	8	VSS/ AVSS								
12	9	XIN	P9_0							
13	10	VCC/ AVCC								
14	11		P8_6			(RXD0/RXD2/SCL2)				
15	12		P8_5			(TXD0/TXD2/SDA2)				
16	13		P8_4			(CLK0/CLK2)				
17	14		P8_3		(TRJ0IO)		SSO	SDA		
18	15		P8_2		(TRJ1IO)		SSCK	SCL		
19	16		P8_1	$\overline{\text{INT3}}$			SSI		IVCMP3	
20	17		P8_0	$\overline{\text{INT1}}$			$\overline{\text{SCS}}$		IVCMP1	
21	18		P5_6							VL3
22	19		P5_5							VL2
23	20		P5_4							VL1
24	21		P5_3							COM0
25	22		P5_2							COM1
26	23		P5_1							COM2
27	24		P5_0							COM3
28	25		P4_7							SEG39/ COMEXP
29	26		P4_6							SEG38
30			P4_5							SEG37

Note:

1. The pin in parentheses can be assigned by a program.

Table 1.16 Pin Name Information by Pin Number (R8C/LA6A Group, R8C/LA8A Group)(2)

Pin Number		Control Pin	Port	I/O Pin Functions for Peripheral Modules						
LA8A	LA6A			Interrupt	Timer	Serial Interface	SSU	I ² C bus	A/D Converter, Comparator B	LCD drive Control Circuit
31			P4_4							SEG36
32			P4_3							SEG35
33			P4_2							SEG34
34			P4_1							SEG33
35			P4_0							SEG32
36	27		P3_7	($\overline{\text{INT7}}$)						SEG31
37	28		P3_6	($\overline{\text{INT6}}$)						SEG30
38	29		P3_5	($\overline{\text{INT5}}$)						SEG29
39	30		P3_4	($\overline{\text{INT4}}$)						SEG28
40	31		P3_3	($\overline{\text{INT3}}$)						SEG27
41	32		P3_2	($\overline{\text{INT2}}$)						SEG26
42	33		P3_1	($\overline{\text{INT1}}$)						SEG25
43	34		P3_0	($\overline{\text{INT0}}$)						SEG24
44	35		P2_7							SEG23
45	36		P2_6							SEG22
46	37		P2_5							SEG21
47	38		P2_4							SEG20
48	39		P2_3							SEG19
49	40		P2_2							SEG18
50	41		P2_1							SEG17
51	42		P2_0							SEG16
52	43		P1_7							SEG15
53	44		P1_6	$\overline{\text{INT6}}$						SEG14
54	45		P1_5	$\overline{\text{INT5}}$						SEG13
55	46		P1_4	$\overline{\text{INT4}}$						SEG12
56	47		P1_3	$\overline{\text{KI7}}$						SEG11
57	48		P1_2	$\overline{\text{KI6}}$						SEG10
58			P1_1							SEG9
59			P1_0							SEG8
60	49		P0_7	$\overline{\text{KI5}}$	TRHO					SEG7
61	50		P0_6	$\overline{\text{KI4}}$						SEG6
62	51		P0_5	$\overline{\text{KI3}}$						SEG5
63	52		P0_4	$\overline{\text{KI2}}$						SEG4
64	53		P0_3	$\overline{\text{KI1}}$ / $\overline{\text{INT0}}$						SEG3
65	54		P0_2	$\overline{\text{KI0}}$	(TRCTRG)					SEG2
66	55		P0_1	$\overline{\text{INT7}}$	(TRCTRG/ TRCCLK)				$\overline{\text{ADTRG}}$	SEG1
67	56		P0_0		(TRCIOA/ TRCTRG)				AN11	SEG0
68	57		P6_7		(TRCIOB)				AN10	

Note:

1. The pin in parentheses can be assigned by a program.

Table 1.17 Pin Name Information by Pin Number (R8C/LA6A Group, R8C/LA8A Group)(3)

Pin Number		Control Pin	Port	I/O Pin Functions for Peripheral Modules						
LA8A	LA6A			Interrupt	Timer	Serial Interface	SSU	I ² C bus	A/D Converter, Comparator B	LCD drive Control Circuit
69	58		P6_6		(TRB00/ TRCIOB/ TRCIOA)				AN9/IVREF3	
70	59		P6_5		(TRB10/ TRCIOB/ TRCIOD)				AN8/IVREF1	
71	60		P6_4				(SSO)	(SDA)	AN7	
72	61		P6_3				(SSCK)	(SCL)	AN6	
73	62		P6_2		(TRJ0IO)		(SSI)		AN5	
74	63		P6_1		(TRJ1IO)		(SCS)		AN4	
75			P6_0		(TRJ2IO)				AN3	
76			P7_6		(TRB00)				AN2	
77			P7_5		TRB10				AN1	
78			P7_4						AN0	
79			P7_3			(CTS2/RTS2)				
80			P7_2		TRJ00	(RXD2/SCL2/ TXD2/SDA2)				

Note:

1. The pin in parentheses can be assigned by a program.

1.5 Pin Functions

Tables 1.18 and 1.19 list Pin Functions for R8C/LA5A Group, and Tables 1.20 and 1.21 list Pin Functions for R8C/LA8A Group.

Table 1.18 Pin Functions for R8C/LA5A Group (1)

Item	Pin Name	I/O Type	Description
Power supply input	VCC, VSS	—	Apply 1.8 V to 5.5 V to the VCC pin. Apply 0 V to the VSS pin.
Analog power supply input	AVCC, AVSS	—	Power supply for the A/D converter. Connect a capacitor between AVCC and AVSS.
Reset input	$\overline{\text{RESET}}$	I	Driving this pin low resets the MCU.
MODE	MODE	I	Connect this pin to VCC via a resistor.
Power-off 0 mode exit input	$\overline{\text{WKUP0}}$	I	This pin is provided for input to exit the mode used in power-off 0 mode. Connect to VSS when not using power-off 0 mode.
	$\overline{\text{WKUP1}}$	I	This pin is provided for input to exit the mode used in power-off 0 mode.
XIN clock input	XIN	I	These pins are provided for XIN clock generation circuit I/O. Connect a ceramic oscillator or a crystal oscillator between pins XIN and XOUT. ⁽¹⁾ To use an external clock, input it to the XIN pin and set XOUT as the I/O port P9_1. When the pin is not used, treat it as an unassigned pin and use the appropriate handling.
XIN clock output	XOUT	O	
XCIN clock input	XCIN	I	These pins are provided for XCIN clock generation circuit I/O. Connect a crystal oscillator between pins XCIN and XCOU. ⁽¹⁾ To use an external clock, input it to the XCIN pin and leave the XCOU pin open.
XCIN clock output	XCOU	O	
$\overline{\text{INT}}$ interrupt input	$\overline{\text{INT0}}$ to $\overline{\text{INT3}}$, $\overline{\text{INT5}}$, $\overline{\text{INT7}}$	I	$\overline{\text{INT}}$ interrupt input pins.
Key input interrupt	$\overline{\text{KI0}}$ to $\overline{\text{KI7}}$	I	Key input interrupt input pins.
Timer RB	TRB00, TRB10	O	Timer RB output pins.
Timer RC	TRCCLK	I	External clock input pin.
	TRCTRG	I	External trigger input pin.
	TRCIOA, TRCIOB, TRCIOC, TRCIOD	I/O	Timer RC I/O pins.
Timer RH	TRHO	O	Timer RH output pin.
Timer RJ	TRJ0IO, TRJ1IO	I/O	Timer RJ I/O pins.
Serial interface	CLK0	I/O	Transfer clock I/O pin.
	RXD0	I	Serial data input pin.
	TXD0	O	Serial data output pin.

I: Input O: Output I/O: Input and output

Note:

- Contact the oscillator manufacturer for oscillation characteristics.

Table 1.19 Pin Functions for R8C/LA5A Group (2)

Item	Pin Name	I/O Type	Description
I ² C bus	SCL	I/O	Clock I/O pin.
	SDA	I/O	Data I/O pin.
SSU	SSI	I/O	Data I/O pin.
	$\overline{\text{SCS}}$	I/O	Chip-select signal I/O pin.
	SSCK	I/O	Clock I/O pin.
	SSO	I/O	Data I/O pin.
Reference voltage input	VREF	I	Reference voltage input pin for the A/D converter.
A/D converter	AN0 to AN6	I	A/D converter analog input pins.
	$\overline{\text{ADTRG}}$	I	AD external trigger input pin.
Comparator B	IVCMP1, IVCMP3	I	Comparator B analog voltage input pins.
	IVREF1, IVREF3	I	Comparator B reference voltage input pins.
I/O ports	P0_0 to P0_7, P2_0 to P2_7, P3_0 to P3_7, P5_0 to P5_6, P7_0 to P7_2, P8_0 to P8_7, P9_0, P9_1	I/O	CMOS I/O ports. Each port has an I/O select direction register, allowing each pin in the port to be directed for input or output individually. Any port set to input can be set to use a pull-up resistor or not by a program. Port P8 can be used as LED drive ports.
Segment output	SEG0 to SEG26	O	LCD segment output pins.
Common output	COM0 to COM3, COMEXP	O	LCD common output pins.
LCD power supply	VL1	I	Apply the following voltage: $1\text{ V} \leq \text{VL1} \leq \text{VCC}$ and $\text{VL1} \leq \text{VL2}$.
	VL2	I	Apply the following voltage: $\text{VL2} \leq 5.5\text{ V}$ and $\text{VL1} \leq \text{VL2} \leq \text{VL3}$.
	VL3	I	Apply the following voltage: $\text{VL3} \leq 5.5\text{ V}$ and $\text{VL2} \leq \text{VL3}$.

I: Input O: Output I/O: Input and output

Note:

1. Contact the oscillator manufacturer for oscillation characteristics.

Table 1.20 Pin Functions for R8C/LA8A Group (1)

Item	Pin Name	I/O Type	Description
Power supply input	VCC, VSS	—	Apply 1.8 V to 5.5 V to the VCC pin. Apply 0 V to the VSS pin.
Analog power supply input	AVCC, AVSS	—	Power supply for the A/D converter. Connect a capacitor between AVCC and AVSS.
Reset input	$\overline{\text{RESET}}$	I	Driving this pin low resets the MCU.
MODE	MODE	I	Connect this pin to VCC via a resistor.
Power-off 0 mode exit input	$\overline{\text{WKUP0}}$	I	This pin is provided for input to exit the mode used in power-off 0 mode. Connect to VSS when not using power-off 0 mode.
	$\overline{\text{WKUP1}}$	I	This pin is provided for input to exit the mode used in power-off 0 mode.
XIN clock input	XIN	I	These pins are provided for XIN clock generation circuit I/O. Connect a ceramic oscillator or a crystal oscillator between pins XIN and XOUT. ⁽¹⁾ To use an external clock, input it to the XIN pin and set XOUT as the I/O port P9_1. When the pin is not used, treat it as an unassigned pin and use the appropriate handling.
XIN clock output	XOUT	O	
XCIN clock input	XCIN	I	These pins are provided for XCIN clock generation circuit I/O. Connect a crystal oscillator between pins XCIN and XCOOUT. ⁽¹⁾ To use an external clock, input it to the XCIN pin and leave the XCOOUT pin open.
XCIN clock output	XCOOUT	O	
$\overline{\text{INT}}$ interrupt input	$\overline{\text{INT0}}$ to $\overline{\text{INT7}}$	I	$\overline{\text{INT}}$ interrupt input pins.
Key input interrupt	$\overline{\text{KI0}}$ to $\overline{\text{KI7}}$	I	Key input interrupt input pins.
Timer RB	TRB0O, TRB1O	O	Timer RB output pins.
Timer RC	TRCCLK	I	External clock input pin.
	TRCTRIG	I	External trigger input pin.
	TRCIOA, TRCIOB, TRCIOC, TRCIOD	I/O	Timer RC I/O pins.
Timer RH	TRHO	O	Timer RH output pin.
Timer RJ	TRJ0IO, TRJ1IO, TRJ2IO	I/O	Timer RJ I/O pins.
	TRJ0IO, TRJ1IO, TRJ2IO	O	Timer RJ output pins.
Serial interface	CLK0, CLK2	I/O	Transfer clock I/O pin.
	RXD0, RXD2	I	Serial data input pin.
	TXD0, TXD2	O	Serial data output pin.
	$\overline{\text{CTS2}}$	I	Transmission control input pin.
	$\overline{\text{RTS2}}$	O	Reception control output pin.
	SCL2	I/O	I ² C mode clock I/O pin.
SDA2	I/O	I ² C mode data I/O pin.	

I: Input O: Output I/O: Input and output

Note:

- Contact the oscillator manufacturer for oscillation characteristics.

Table 1.21 Pin Functions for R8C/LA8A Group (2)

Item	Pin Name	I/O Type	Description
I ² C bus	SCL	I/O	Clock I/O pin.
	SDA	I/O	Data I/O pin.
SSU	SSI	I/O	Data I/O pin.
	$\overline{\text{SCS}}$	I/O	Chip-select signal I/O pin.
	SSCK	I/O	Clock I/O pin.
	SSO	I/O	Data I/O pin.
Reference voltage input	VREF	I	Reference voltage input pin for the A/D converter.
A/D converter	AN0 to AN11	I	A/D converter analog input pins.
	$\overline{\text{ADTRG}}$	I	AD external trigger input pin.
Comparator B	IVCMP1, IVCMP3	I	Comparator B analog voltage input pins.
	IVREF1, IVREF3	I	Comparator B reference voltage input pins.
I/O ports	P0_0 to P0_7, P1_0 to P1_7, P2_0 to P2_7, P3_0 to P3_7, P4_0 to P4_7, P5_0 to P5_6, P6_0 to P6_7, P7_0 to P7_6, P8_0 to P8_7, P9_0, P9_1	I/O	CMOS I/O ports. Each port has an I/O select direction register, allowing each pin in the port to be directed for input or output individually. Any port set to input can be set to use a pull-up resistor or not by a program. Ports P7_0, P7_1 and P8 can be used as LED drive ports.
Segment output	SEG0 to SEG39	O	LCD segment output pins.
Common output	COM0 to COM3, COMEXP	O	LCD common output pins.
LCD power supply	VL1	I	Apply the following voltage: $1\text{ V} \leq \text{VL1} \leq \text{VCC}$ and $\text{VL1} \leq \text{VL2}$.
	VL2	I	Apply the following voltage: $\text{VL2} \leq 5.5\text{ V}$ and $\text{VL1} \leq \text{VL2} \leq \text{VL3}$.
	VL3	I	Apply the following voltage: $\text{VL3} \leq 5.5\text{ V}$ and $\text{VL2} \leq \text{VL3}$.

I: Input O: Output I/O: Input and output

Note:

1. Contact the oscillator manufacturer for oscillation characteristics.

2. Central Processing Unit (CPU)

Figure 2.1 shows the CPU Registers. The CPU contains 13 registers. R0, R1, R2, R3, A0, A1, and FB configure a register bank. There are two sets of register banks.

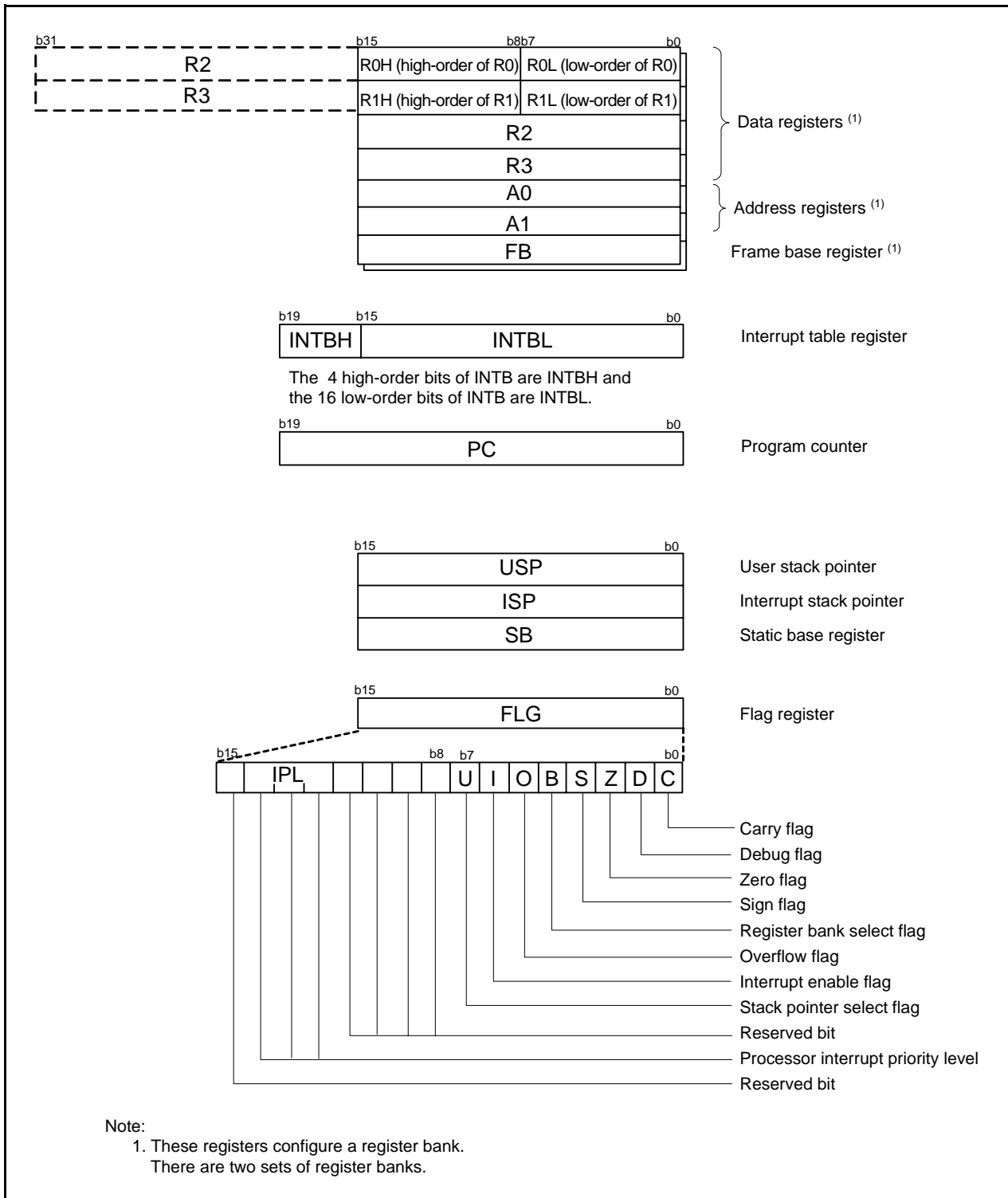

Figure 2.1 CPU Registers

2.1 Data Registers (R0, R1, R2, and R3)

R0 is a 16-bit register for transfer, arithmetic, and logic operations. The same applies to R1 to R3. R0 can be split into high-order bits (R0H) and low-order bits (R0L) to be used separately as 8-bit data registers. R1H and R1L are analogous to R0H and R0L. R2 can be combined with R0 and used as a 32-bit data register (R2R0). R3R1 is analogous to R2R0.

2.2 Address Registers (A0 and A1)

A0 is a 16-bit register for address register indirect addressing and address register relative addressing. It is also used for transfer, arithmetic, and logic operations. A1 is analogous to A0. A1 can be combined with A0 and as a 32-bit address register (A1A0).

2.3 Frame Base Register (FB)

FB is a 16-bit register for FB relative addressing.

2.4 Interrupt Table Register (INTB)

INTB is a 20-bit register that indicates the starting address of an interrupt vector table.

2.5 Program Counter (PC)

PC is 20 bits wide and indicates the address of the next instruction to be executed.

2.6 User Stack Pointer (USP) and Interrupt Stack Pointer (ISP)

The stack pointers (SP), USP and ISP, are each 16 bits wide. The U flag of FLG is used to switch between USP and ISP.

2.7 Static Base Register (SB)

SB is a 16-bit register for SB relative addressing.

2.8 Flag Register (FLG)

FLG is an 11-bit register indicating the CPU state.

2.8.1 Carry Flag (C)

The C flag retains carry, borrow, or shift-out bits that have been generated by the arithmetic and logic unit.

2.8.2 Debug Flag (D)

The D flag is for debugging only. Set it to 0.

2.8.3 Zero Flag (Z)

The Z flag is set to 1 when an arithmetic operation results in 0; otherwise to 0.

2.8.4 Sign Flag (S)

The S flag is set to 1 when an arithmetic operation results in a negative value; otherwise to 0.

2.8.5 Register Bank Select Flag (B)

Register bank 0 is selected when the B flag is 0. Register bank 1 is selected when this flag is set to 1.

2.8.6 Overflow Flag (O)

The O flag is set to 1 when an operation results in an overflow; otherwise to 0.

2.8.7 Interrupt Enable Flag (I)

The I flag enables maskable interrupts.

Interrupts are disabled when the I flag is set to 0, and are enabled when the I flag is set to 1. The I flag is set to 0 when an interrupt request is acknowledged.

2.8.8 Stack Pointer Select Flag (U)

ISP is selected when the U flag is set to 0; USP is selected when the U flag is set to 1.

The U flag is set to 0 when a hardware interrupt request is acknowledged or the INT instruction of software interrupt numbers 0 to 31 is executed.

2.8.9 Processor Interrupt Priority Level (IPL)

IPL is 3 bits wide and assigns processor interrupt priority levels from level 0 to level 7.

If a requested interrupt has higher priority than IPL, the interrupt is enabled.

2.8.10 Reserved Bit

If necessary, set to 0. When read, the content is undefined.

3. Memory

Figure 3.1 shows a Memory Map of each group. Each group has a 1-Mbyte address space from addresses 00000h to FFFFFh. For example, a 48-Kbyte internal ROM area is allocated addresses 04000h to 0FFFFh.

The fixed interrupt vector table is allocated addresses 0FFDCh to 0FFFFh. The starting address of each interrupt routine is stored here.

The internal ROM (data flash) is allocated higher addresses, beginning with address 03000h.

For example, two 1-Kbyte internal ROM (data flash) areas are allocated addresses 03000h to 037FFh. Two 2-Kbyte internal RAM (data flash) areas are allocated addresses 03000h to 03FFFh.

The internal RAM is allocated higher addresses, beginning with address 00400h. For example, a 3.5-Kbyte internal RAM area is allocated addresses 00400h to 011FFh. The internal RAM is used not only for data storage but also as a stack area when a subroutine is called or when an interrupt request is acknowledged.

Special function registers (SFRs) are allocated addresses 00000h to 002FFh and 02C00h to 02FFFh. Peripheral function control registers are allocated here. All unallocated spaces within the SFRs are reserved and cannot be accessed by users.

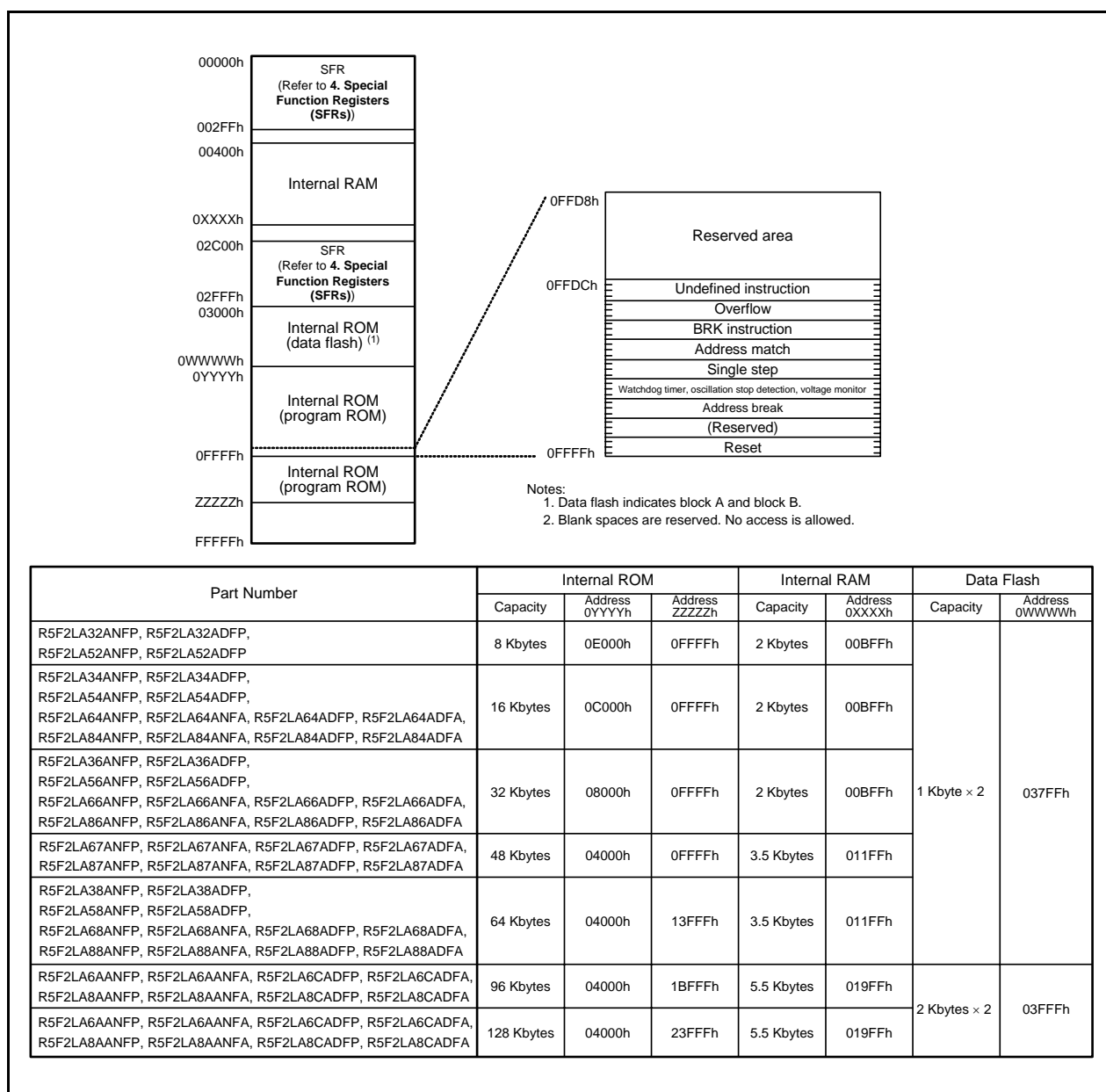

Figure 3.1 Memory Map

4. Special Function Registers (SFRs)

An SFR (special function register) is a control register for a peripheral function. Tables 4.1 to 4.9 list SFR information for R8C/LA5A Group, Tables 4.10 to 4.18 list SFR information for R8C/LA8A Group, and Table 4.19 lists the ID Code Areas and Option Function Select Area. The description offered in this chapter is based on the R8C/LA8A Group.

Table 4.1 SFR Information for R8C/LA5A Group (1) (1)

Address	Register	Symbol	After Reset
0000h			
0001h			
0002h			
0003h			
0004h	Processor Mode Register 0	PM0	00h
0005h	Processor Mode Register 1	PM1	00h 00000100b (2)
0006h	System Clock Control Register 0	CM0	00100000b
0007h	System Clock Control Register 1	CM1	00100000b
0008h	Module Standby Control Register 0	MSTCR0	00h
0009h	System Clock Control Register 3	CM3	00h
000Ah	Protect Register	PRCR	00h
000Bh	Reset Source Determination Register	RSTFR	XXh (3)
000Ch	Oscillation Stop Detection Register	OCD	00000100b (4) 00h (4)
000Dh	Watchdog Timer Reset Register	WDTR	XXh
000Eh	Watchdog Timer Start Register	WDTS	XXh
000Fh	Watchdog Timer Control Register	WDTC	00111111b
0010h	Module Standby Control Register 1	MSTCR1	00h
0011h			
0012h			
0013h			
0014h			
0015h			
0016h			
0017h			
0018h			
0019h			
001Ah			
001Bh			
001Ch	Count Source Protection Mode Register	CSPR	00h 10000000b (5)
001Dh			
001Eh			
001Fh			
0020h	Power-Off Mode Control Register 0	POMCR0	XXXXXX00b
0021h			
0022h			
0023h	High-Speed On-Chip Oscillator Control Register 0	FRA0	00h
0024h	High-Speed On-Chip Oscillator Frequency Control Register 0	FRC0	When shipping
0025h	High-Speed On-Chip Oscillator Control Register 2	FRA2	00h
0026h	On-Chip Reference Voltage Control Register	OCVREFCR	00h
0027h			
0028h			
0029h	High-Speed On-Chip Oscillator 18 MHz Set Value Register 0	FR18S0	XXh
002Ah	High-Speed On-Chip Oscillator 18 MHz Set Value Register 1	FR18S1	XXh
002Bh			
002Ch			
002Dh			
002Eh			
002Fh	High-Speed On-Chip Oscillator Frequency Control Register 1	FRC1	When shipping
0030h	Voltage Monitor Circuit Control Register	CMPA	00h
0031h	Voltage Monitor Circuit Edge Select Register	VCAC	00h
0032h			
0033h	Voltage Detect Register 1	VCA1	00001000b
0034h	Voltage Detect Register 2	VCA2	00h (6) 00100000b (7)
0035h			
0036h	Voltage Detection 1 Level Select Register	VD1LS	00000111b
0037h			
0038h	Voltage Monitor 0 Circuit Control Register	VW0C	1100X010b (6) 1100X011b (7)
0039h	Voltage Monitor 1 Circuit Control Register	VW1C	10001010b

X: Undefined

Notes:

- Blank spaces are reserved. No access is allowed.
- The CSPRO bit in the CSPR register is set to 1.
- The CWR bit in the RSTFR register is set to 0 after power-on, voltage monitor 0 reset, or exit from power-off 0 mode. Hardware reset, software reset, or watchdog timer reset does not affect this bit.
- The reset value differs depending on the mode.
- The CSPROINI bit in the OFS register is set to 0.
- The LVDAS bit in the OFS register is set to 1.
- The LVDAS bit in the OFS register is set to 0.

Table 4.2 SFR Information for R8C/LA5A Group (2) (1)

Address	Register	Symbol	After Reset
003Ah	Voltage Monitor 2 Circuit Control Register	VW2C	10000010b
003Bh			
003Ch			
003Dh			
003Eh			
003Fh			
0040h			
0041h	Flash Memory Ready Interrupt Control Register	FMRDYIC	XXXXX000b
0042h			
0043h	INT7 Interrupt Control Register	INT7IC	XX00X000b
0044h			
0045h	INT5 Interrupt Control Register	INT5IC	XX00X000b
0046h			
0047h	Timer RC Interrupt Control Register	TRCIC	XXXXX000b
0048h			
0049h			
004Ah	Timer RH Interrupt Control Register	TRHIC	XXXXX000b
004Bh			
004Ch			
004Dh	Key Input Interrupt Control Register	KUPIC	XXXXX000b
004Eh	A/D Conversion Interrupt Control Register	ADIC	XXXXX000b
004Fh	SSU Interrupt Control Register / IIC bus Interrupt Control Register (2)	SSUIC/IICIC	XXXXX000b
0050h			
0051h	UART0 Transmit Interrupt Control Register	S0TIC	XXXXX000b
0052h	UART0 Receive Interrupt Control Register	S0RIC	XXXXX000b
0053h			
0054h			
0055h	INT2 Interrupt Control Register	INT2IC	XX00X000b
0056h	Timer RJ0 Interrupt Control Register	TRJ0IC	XXXXX000b
0057h	Timer RB1 Interrupt Control Register	TRB1IC	XXXXX000b
0058h	Timer RB0 Interrupt Control Register	TRB0IC	XXXXX000b
0059h	INT1 Interrupt Control Register	INT1IC	XX00X000b
005Ah	INT3 Interrupt Control Register	INT3IC	XX00X000b
005Bh	Timer RJ1 Interrupt Control Register	TRJ1IC	XXXXX000b
005Ch			
005Dh	INT0 Interrupt Control Register	INT0IC	XX00X000b
005Eh			
005Fh			
0060h			
0061h			
0062h			
0063h			
0064h			
0065h			
0066h			
0067h			
0068h			
0069h			
006Ah	LCD Interrupt Control Register	LCDIC	XXXXX000b
006Bh			
006Ch			
006Dh			
006Eh			
006Fh			
0070h			
0071h			
0072h	Voltage monitor 1 Interrupt Control Register	VCMP1IC	XXXXX000b
0073h	Voltage monitor 2 Interrupt Control Register	VCMP2IC	XXXXX000b
0074h			
0075h			
0076h			
0077h			
0078h			
0079h			
007Ah			
007Bh			
007Ch			
007Dh			
007Eh			
007Fh			

X: Undefined

Notes:

- Blank spaces are reserved. No access is allowed.
- Selectable by the IICSEL bit in the SSUICSR register.

Table 4.3 SFR Information for R8C/LA5A Group (3) (1)

Address	Register	Symbol	After Reset
0080h	Timer RJ0 Control Register	TRJ0CR	00h
0081h	Timer RJ0 I/O Control Register	TRJ0IOC	00h
0082h	Timer RJ0 Mode Register	TRJ0MR	00h
0083h	Timer RJ0 Event Pin Select Register	TRJ0ISR	00h
0084h	Timer RJ0 Register	TRJ0	FFh
0085h			FFh
0086h			
0087h			
0088h	Timer RJ1 Control Register	TRJ1CR	00h
0089h	Timer RJ1 I/O Control Register	TRJ1IOC	00h
008Ah	Timer RJ1 Mode Register	TRJ1MR	00h
008Bh	Timer RJ1 Event Pin Select Register	TRJ1ISR	00h
008Ch	Timer RJ1 Register	TRJ1	FFh
008Dh			FFh
008Eh			
008Fh			
0090h			
0091h			
0092h			
0093h			
0094h			
0095h			
0096h			
0097h			
0098h	Timer RB1 Control Register	TRB1CR	00h
0099h	Timer RB1 One-Shot Control Register	TRB1OCR	00h
009Ah	Timer RB1 I/O Control Register	TRB1IOC	00h
009Bh	Timer RB1 Mode Register	TRB1MR	00h
009Ch	Timer RB1 Prescaler Register	TRB1PRE	FFh
009Dh	Timer RB1 Secondary Register	TRB1SC	FFh
009Eh	Timer RB1 Primary Register	TRB1PR	FFh
009Fh			
00A0h	UART0 Transmit/Receive Mode Register	U0MR	00h
00A1h	UART0 Bit Rate Register	U0BRG	XXh
00A2h	UART0 Transmit Buffer Register	U0TB	XXh
00A3h			XXh
00A4h	UART0 Transmit/Receive Control Register 0	U0C0	00001000b
00A5h	UART0 Transmit/Receive Control Register 1	U0C1	00000010b
00A6h	UART0 Receive Buffer Register	U0RB	XXh
00A7h			XXh
00A8h			
00A9h			
00AAh			
00ABh			
00ACh			
00ADh			
00AEh			
00AFh			
00B0h			
00B1h			
00B2h			
00B3h			
00B4h			
00B5h			
00B6h			
00B7h			
00B8h			
00B9h			
00BAh			
00BBh			
00BCh			
00BDh			
00BEh			
00BFh			

X: Undefined

Note:

- Blank spaces are reserved. No access is allowed.

Table 4.4 SFR Information for R8C/LA5A Group (4) (1)

Address	Register	Symbol	After Reset
00C0h	A/D Register 0	AD0	XXh
00C1h			000000XXb
00C2h	A/D Register 1	AD1	XXh
00C3h			000000XXb
00C4h	A/D Register 2	AD2	XXh
00C5h			000000XXb
00C6h	A/D Register 3	AD3	XXh
00C7h			000000XXb
00C8h	A/D Register 4	AD4	XXh
00C9h			000000XXb
00CAh	A/D Register 5	AD5	XXh
00CBh			000000XXb
00CCh	A/D Register 6	AD6	XXh
00CDh			000000XXb
00CEh	A/D Register 7	AD7	XXh
00CFh			000000XXb
00D0h			
00D1h			
00D2h			
00D3h			
00D4h	A/D Mode Register	ADMOD	00h
00D5h	A/D Input Select Register	ADINSEL	11000000b
00D6h	A/D Control Register 0	ADCON0	00h
00D7h	A/D Control Register 1	ADCON1	00h
00D8h			
00D9h			
00DAh			
00DBh			
00DCh			
00DDh	A/D Control Register 2	ADCON2	00h
00DEh			
00DFh			
00E0h	Port P0 Register	P0	XXh
00E1h			
00E2h	Port P0 Direction Register	PD0	00h
00E3h			
00E4h	Port P2 Register	P2	XXh
00E5h	Port P3 Register	P3	XXh
00E6h	Port P2 Direction Register	PD2	00h
00E7h	Port P3 Direction Register	PD3	00h
00E8h			
00E9h	Port P5 Register	P5	XXh
00EAh			
00EBh	Port P5 Direction Register	PD5	00h
00ECh			
00EDh	Port P7 Register	P7	XXh
00EEh			
00EFh	Port P7 Direction Register	PD7	00h
00F0h	Port P8 Register	P8	XXh
00F1h	Port P9 Register	P9	XXh
00F2h	Port P8 Direction Register	PD8	00h
00F3h	Port P9 Direction Register	PD9	00h
00F4h			
00F5h			
00F6h			
00F7h			
00F8h			
00F9h			
00FAh			
00FBh			
00FCh			
00FDh			
00FEh			
00FFh			

X: Undefined

Note:

- Blank spaces are reserved. No access is allowed.

Table 4.5 SFR Information for R8C/LA5A Group (5) (1)

Address	Register	Symbol	After Reset
0100h			
0101h			
0102h			
0103h			
0104h			
0105h			
0106h			
0107h			
0108h	Timer RB0 Control Register	TRB0CR	00h
0109h	Timer RB0 One-Shot Control Register	TRB0OCR	00h
010Ah	Timer RB0 I/O Control Register	TRB0IOC	00h
010Bh	Timer RB0 Mode Register	TRB0MR	00h
010Ch	Timer RB0 Prescaler Register	TRB0PRE	FFh
010Dh	Timer RB0 Secondary Register	TRB0SC	FFh
010Eh	Timer RB0 Primary Register	TRB0PR	FFh
010Fh			
0110h	Timer RH Second Data Register / Counter Data Register	TRHSEC	XXh 00h (2)
0111h	Timer RH Minute Data Register / Compare Data Register	TRHMIN	XXh 00h (2)
0112h	Timer RH Hour Data Register	TRHHR	00XXXXXXb 00h (2)
0113h	Timer RH Day-of-the-Week Data Register	TRHWK	00000XXXb 00h (2)
0114h	Timer RH Date Data Register	TRHDY	00XXXXXXb 00000001b (2)
0115h	Timer RH Month Data Register	TRHMON	000XXXXXb 00000001b (2)
0116h	Timer RH Year Data Register	TRHYR	XXh 00h (2)
0117h	Timer RH Control Register	TRHCR	XXX000XXb 000XX1X0b (2)
0118h	Timer RH Count Source Select Register	TRHCSR	X0001000b 0XXXXXXXb (2)
0119h	Timer RH Clock Error Correction Register	TRHADJ	XXh 00h (2)
011Ah	Timer RH Interrupt Flag Register	TRHIFR	00000XXXb 000XX000b (2)
011Bh	Timer RH Interrupt Enable Register	TRHIER	XXh 00h (2)
011Ch	Timer RH Alarm Minute Register	TRHAMN	XXh 00h (2)
011Dh	Timer RH Alarm Hour Register	TRHAHR	XXh 00h (2)
011Eh	Timer RH Alarm Day-of-the-Week Register	TRHAWK	X0000XXXb 00h (2)
011Fh	Timer RH Protect Register	TRHPRC	00h X0000000b (2)
0120h	Timer RC Mode Register	TRCMR	01001000b
0121h	Timer RC Control Register 1	TRCCR1	00h
0122h	Timer RC Interrupt Enable Register	TRCIER	01110000b
0123h	Timer RC Status Register	TRCSR	01110000b
0124h	Timer RC I/O Control Register 0	TRCIOR0	10001000b
0125h	Timer RC I/O Control Register 1	TRCIOR1	10001000b
0126h	Timer RC Counter	TRC	00h 00h
0127h			
0128h	Timer RC General Register A	TRCGRA	FFh FFh
0129h			
012Ah	Timer RC General Register B	TRCGRB	FFh FFh
012Bh			
012Ch	Timer RC General Register C	TRCGRC	FFh FFh
012Dh			
012Eh	Timer RC General Register D	TRCGRD	FFh FFh
012Fh			
0130h	Timer RC Control Register 2	TRCCR2	00011000b
0131h	Timer RC Digital Filter Function Select Register	TRCDF	00h
0132h	Timer RC Output Master Enable Register	TRCOER	01111111b
0133h	Timer RC Trigger Control Register	TRCADCR	00h
0134h			
0135h			
0136h			
0137h			
0138h			
0139h			
013Ah			
013Bh			
013Ch			
013Dh			
013Eh			
013Fh			

X: Undefined

Notes:

- Blank spaces are reserved. No access is allowed.
- This is the reset value after reset by RTCRST bit in TRHCR register.

Table 4.6 SFR Information for R8C/LA5A Group (6) (1)

Address	Register	Symbol	After Reset
0140h			
0141h			
0142h			
0143h			
0144h			
0145h			
0146h			
0147h			
0148h			
0149h			
014Ah			
014Bh			
014Ch			
014Dh			
014Eh			
014Fh			
0150h			
0151h			
0152h			
0153h			
0154h			
0155h			
0156h			
0157h			
0158h			
0159h			
015Ah			
015Bh			
015Ch			
015Dh			
015Eh			
015Fh			
0160h			
0161h			
0162h			
0163h			
0164h			
0165h			
0166h			
0167h			
0168h			
0169h			
016Ah			
016Bh			
016Ch			
016Dh			
016Eh			
016Fh			
0170h			
0171h			
0172h			
0173h			
0174h			
0175h			
0176h			
0177h			
0178h			
0179h			
017Ah			
017Bh			
017Ch			
017Dh			
017Eh			
017Fh			

X: Undefined

Note:

- Blank spaces are reserved. No access is allowed.

Table 4.7 SFR Information for R8C/LA5A Group (7) (1)

Address	Register	Symbol	After Reset
0180h	Timer RJ Pin Select Register	TRJSR	00h
0181h			
0182h	Timer RC Pin Select Register 0	TRCPSR0	00h
0183h	Timer RC Pin Select Register 1	TRCPSR1	00h
0184h			
0185h			
0186h			
0187h			
0188h	UART0 Pin Select Register	U0SR	00h
0189h			
018Ah			
018Bh			
018Ch	SSU/IIC Pin Select Register	SSUICSR	00h
018Dh	Timer RH Second Interrupt Control Register	TRHICR	X0XXXXXXb 00000001b (3)
018Eh	INT Interrupt Input Pin Select Register	INTSR	00h
018Fh	I/O Function Pin Select Register	PINSR	00h
0190h			
0191h			
0192h			
0193h	SS Bit Counter Register	SSBR	11111000b
0194h	SS Transmit Data Register L / IIC bus Transmit Data Register (2)	SSTDR/ICDRT	FFh
0195h	SS Transmit Data Register H (2)	SSTDRH	FFh
0196h	SS Receive Data Register L / IIC bus Receive Data Register (2)	SSRDR/ICDRR	FFh
0197h	SS Receive Data Register H (2)	SSRDRH	FFh
0198h	SS Control Register H / IIC bus Control Register 1 (2)	SSCRH/ICCR1	00h
0199h	SS Control Register L / IIC bus Control Register 2 (2)	SSCRL/ICCR2	01111101b
019Ah	SS Mode Register / IIC bus Mode Register (2)	SSMR/ICMR	00010000b/00011000b
019Bh	SS Enable Register / IIC bus Interrupt Enable Register (2)	SSER/ICIER	00h
019Ch	SS Status Register / IIC bus Status Register (2)	SSSR/ICSR	00h/0000X000b
019Dh	SS Mode Register 2 / Slave Address Register (2)	SSMR2/SAR	00h
019Eh			
019Fh			
01A0h			
01A1h			
01A2h			
01A3h			
01A4h			
01A5h			
01A6h			
01A7h			
01A8h			
01A9h			
01AAh			
01ABh			
01ACh			
01ADh			
01AEh			
01AFh			
01B0h			
01B1h			
01B2h	Flash Memory Status Register	FST	10000X00b
01B3h			
01B4h	Flash Memory Control Register 0	FMR0	00h
01B5h	Flash Memory Control Register 1	FMR1	000000X0b
01B6h	Flash Memory Control Register 2	FMR2	00h
01B7h			
01B8h			
01B9h			
01BAh			
01BBh			
01BCh			
01BDh			
01BEh			
01BFh			

X: Undefined

Notes:

- Blank spaces are reserved. No access is allowed.
- Selectable by the IICSEL bit in the SSUICSR register.
- This is the reset value after reset by RTCRST bit in TRHCR register.

Table 4.8 SFR Information for R8C/LA5A Group (8) (1)

Address	Register	Symbol	After Reset
01C0h	Address Match Interrupt Register 0	RMAD0	XXh
01C1h			XXh
01C2h			0000XXXXb
01C3h	Address Match Interrupt Enable Register 0	AIER0	00h
01C4h	Address Match Interrupt Register 1	RMAD1	XXh
01C5h			XXh
01C6h			0000XXXXb
01C7h	Address Match Interrupt Enable Register 1	AIER1	00h
01C8h			
01C9h			
01CAh			
01CBh			
01CCh			
01CDh			
01CEh			
01CFh			
01D0h			
01D1h			
01D2h			
01D3h			
01D4h			
01D5h			
01D6h			
01D7h			
01D8h			
01D9h			
01DAh			
01DBh			
01DCh			
01DDh			
01DEh			
01DFh			
01E0h	Port P0 Pull-Up Control Register	P0PUR	00h
01E1h			
01E2h	Port P2 Pull-Up Control Register	P2PUR	00h
01E3h	Port P3 Pull-Up Control Register	P3PUR	00h
01E4h			
01E5h	Port P5 Pull-Up Control Register	P5PUR	00h
01E6h			
01E7h	Port P7 Pull-Up Control Register	P7PUR	00h
01E8h	Port P8 Pull-Up Control Register	P8PUR	00h
01E9h	Port P9 Pull-Up Control Register	P9PUR	00h
01EAh			
01EBh			
01ECh			
01EDh			
01EEh			
01EFh			
01F0h			
01F1h	Port P8 Drive Capacity Control Register	P8DRR	00h
01F2h			
01F3h			
01F4h			
01F5h	Input Threshold Control Register 0	VLT0	00h
01F6h	Input Threshold Control Register 1	VLT1	00h
01F7h	Input Threshold Control Register 2	VLT2	00h
01F8h	Comparator B Control Register 0	INTCMP	00h
01F9h			
01FAh	External Input Enable Register 0	INTEN	00h
01FBh	External Input Enable Register 1	INTEN1	00h
01FCh	INT Input Filter Select Register 0	INTF	00h
01FDh	INT Input Filter Select Register 1	INTF1	00h
01FEh	Key Input Enable Register 0	KIEN	00h
01FFh	Key Input Enable Register 1	KIEN1	00h

X: Undefined

Note:

- Blank spaces are reserved. No access is allowed.

Table 4.9 SFR Information for R8C/LA5A Group (9) (1)

Address	Register	Symbol	After Reset
0200h	LCD Control Register	LCR0	00h
0201h			
0202h	LCD Option Clock Control Register	LCR2	00h
0203h	LCD Clock Control Register	LCR3	00h
0204h	LCD Display Control Register	LCR4	00h
0205h			
0206h	LCD Port Select Register 0	LSE0	00h
0207h	LCD Port Select Register 1	LSE1	00h
0208h	LCD Port Select Register 2	LSE2	00h
0209h			
020Ah			
020Bh	LCD Port Select Register 5	LSE5	00h
020Ch			
020Dh			
020Eh			
020Fh			
0210h	LCD Display Data Register	LRA0L	XXh
0211h		LRA1L	XXh
0212h		LRA2L	XXh
0213h		LRA3L	XXh
0214h		LRA4L	XXh
0215h		LRA5L	XXh
0216h		LRA6L	XXh
0217h		LRA7L	XXh
0218h		LRA8L	XXh
0219h		LRA9L	XXh
021Ah		LRA10L	XXh
021Bh		LRA11L	XXh
021Ch		LRA12L	XXh
021Dh		LRA13L	XXh
021Eh		LRA14L	XXh
021Fh		LRA15L	XXh
0220h		LRA16L	XXh
0221h		LRA17L	XXh
0222h		LRA18L	XXh
0223h		LRA19L	XXh
0224h		LRA20L	XXh
0225h		LRA21L	XXh
0226h		LRA22L	XXh
0227h		LRA23L	XXh
0228h		LRA24L	XXh
0229h		LRA25L	XXh
022Ah		LRA26L	XXh
022Bh			
022Ch			
022Dh			
022Eh			
022Fh			
0230h			
0231h			
0232h			
0233h			
0234h			
0235h			
0236h			
0237h			
:			
2FFh			

X: Undefined

Note:

- Blank spaces are reserved. No access is allowed.

Table 4.10 SFR Information for R8C/LA8A Group (1) (1)

Address	Register	Symbol	After Reset
0000h			
0001h			
0002h			
0003h			
0004h	Processor Mode Register 0	PM0	00h
0005h	Processor Mode Register 1	PM1	00h 00000100b (2)
0006h	System Clock Control Register 0	CM0	00100000b
0007h	System Clock Control Register 1	CM1	00100000b
0008h	Module Standby Control Register 0	MSTCR0	00h
0009h	System Clock Control Register 3	CM3	00h
000Ah	Protect Register	PRCR	00h
000Bh	Reset Source Determination Register	RSTFR	XXh (3)
000Ch	Oscillation Stop Detection Register	OCD	00000100b (4) 00h (4)
000Dh	Watchdog Timer Reset Register	WDTR	XXh
000Eh	Watchdog Timer Start Register	WDTS	XXh
000Fh	Watchdog Timer Control Register	WDTC	00111111b
0010h	Module Standby Control Register 1	MSTCR1	00h
0011h			
0012h			
0013h			
0014h			
0015h			
0016h			
0017h			
0018h			
0019h			
001Ah			
001Bh			
001Ch	Count Source Protection Mode Register	CSPR	00h 10000000b (5)
001Dh			
001Eh			
001Fh			
0020h	Power-Off Mode Control Register 0	POMCR0	XXXXXX00b
0021h			
0022h			
0023h	High-Speed On-Chip Oscillator Control Register 0	FRA0	00h
0024h	High-Speed On-Chip Oscillator Frequency Control Register 0	FRC0	When shipping
0025h	High-Speed On-Chip Oscillator Control Register 2	FRA2	00h
0026h	On-Chip Reference Voltage Control Register	OCVREFCR	00h
0027h			
0028h			
0029h	High-Speed On-Chip Oscillator 18 MHz Set Value Register 0	FR18S0	XXh
002Ah	High-Speed On-Chip Oscillator 18 MHz Set Value Register 1	FR18S1	XXh
002Bh			
002Ch			
002Dh			
002Eh			
002Fh	High-Speed On-Chip Oscillator Frequency Control Register 1	FRC1	When shipping
0030h	Voltage Monitor Circuit Control Register	CMPA	00h
0031h	Voltage Monitor Circuit Edge Select Register	VCAC	00h
0032h			
0033h	Voltage Detect Register 1	VCA1	00001000b
0034h	Voltage Detect Register 2	VCA2	00h (6) 00100000b (7)
0035h			
0036h	Voltage Detection 1 Level Select Register	VD1LS	00000111b
0037h			
0038h	Voltage Monitor 0 Circuit Control Register	VW0C	1100X010b (6) 1100X011b (7)
0039h	Voltage Monitor 1 Circuit Control Register	VW1C	10001010b

X: Undefined

Notes:

- Blank spaces are reserved. No access is allowed.
- The CSPO bit in the CSPR register is set to 1.
- The CWR bit in the RSTFR register is set to 0 after power-on, voltage monitor 0 reset, or exit from power-off 0 mode. Hardware reset, software reset, or watchdog timer reset does not affect this bit.
- The reset value differs depending on the mode.
- The CSPOINI bit in the OFS register is set to 0.
- The LVDAS bit in the OFS register is set to 1.
- The LVDAS bit in the OFS register is set to 0.

Table 4.11 SFR Information for R8C/LA8A Group (2) (1)

Address	Register	Symbol	After Reset
003Ah	Voltage Monitor 2 Circuit Control Register	VW2C	10000010b
003Bh			
003Ch			
003Dh			
003Eh			
003Fh			
0040h			
0041h	Flash Memory Ready Interrupt Control Register	FMRDYIC	XXXXX000b
0042h			
0043h	INT7 Interrupt Control Register	INT7IC	XX00X000b
0044h	INT6 Interrupt Control Register	INT6IC	XX00X000b
0045h	INT5 Interrupt Control Register	INT5IC	XX00X000b
0046h	INT4 Interrupt Control Register	INT4IC	XX00X000b
0047h	Timer RC Interrupt Control Register	TRCIC	XXXXX000b
0048h			
0049h			
004Ah	Timer RH Interrupt Control Register	TRHIC	XXXXX000b
004Bh	UART2 Transmit Interrupt Control Register	S2TIC	XXXXX000b
004Ch	UART2 Receive Interrupt Control Register	S2RIC	XXXXX000b
004Dh	Key Input Interrupt Control Register	KUPIC	XXXXX000b
004Eh	A/D Conversion Interrupt Control Register	ADIC	XXXXX000b
004Fh	SSU Interrupt Control Register / IIC bus Interrupt Control Register (2)	SSUIC/IICIC	XXXXX000b
0050h			
0051h	UART0 Transmit Interrupt Control Register	S0TIC	XXXXX000b
0052h	UART0 Receive Interrupt Control Register	S0RIC	XXXXX000b
0053h			
0054h			
0055h	INT2 Interrupt Control Register	INT2IC	XX00X000b
0056h	Timer RJ0 Interrupt Control Register	TRJ0IC	XXXXX000b
0057h	Timer RB1 Interrupt Control Register	TRB1IC	XXXXX000b
0058h	Timer RB0 Interrupt Control Register	TRB0IC	XXXXX000b
0059h	INT1 Interrupt Control Register	INT1IC	XX00X000b
005Ah	INT3 Interrupt Control Register	INT3IC	XX00X000b
005Bh	Timer RJ1 Interrupt Control Register	TRJ1IC	XXXXX000b
005Ch	Timer RJ2 Interrupt Control Register	TRJ2IC	XXXXX000b
005Dh	INT0 Interrupt Control Register	INT0IC	XX00X000b
005Eh	UART2 Bus Collision Detection Interrupt Control Register	U2BCNIC	XXXXX000b
005Fh			
0060h			
0061h			
0062h			
0063h			
0064h			
0065h			
0066h			
0067h			
0068h			
0069h			
006Ah	LCD Interrupt Control Register	LCDIC	XXXXX000b
006Bh			
006Ch			
006Dh			
006Eh			
006Fh			
0070h			
0071h			
0072h	Voltage monitor 1 Interrupt Control Register	VCMP1IC	XXXXX000b
0073h	Voltage monitor 2 Interrupt Control Register	VCMP2IC	XXXXX000b
0074h			
0075h			
0076h			
0077h			
0078h			
0079h			
007Ah			
007Bh			
007Ch			
007Dh			
007Eh			
007Fh			

X: Undefined

Notes:

- Blank spaces are reserved. No access is allowed.
- Selectable by the IICSEL bit in the SSUIICSR register.

Table 4.12 SFR Information for R8C/LA8A Group (3) (1)

Address	Register	Symbol	After Reset
0080h	Timer RJ0 Control Register	TRJ0CR	00h
0081h	Timer RJ0 I/O Control Register	TRJ0IOC	00h
0082h	Timer RJ0 Mode Register	TRJ0MR	00h
0083h	Timer RJ0 Event Pin Select Register	TRJ0ISR	00h
0084h	Timer RJ0 Register	TRJ0	FFh
0085h			FFh
0086h			
0087h			
0088h	Timer RJ1 Control Register	TRJ1CR	00h
0089h	Timer RJ1 I/O Control Register	TRJ1IOC	00h
008Ah	Timer RJ1 Mode Register	TRJ1MR	00h
008Bh	Timer RJ1 Event Pin Select Register	TRJ1ISR	00h
008Ch	Timer RJ1 Register	TRJ1	FFh
008Dh			FFh
008Eh			
008Fh			
0090h	Timer RJ2 Control Register	TRJ2CR	00h
0091h	Timer RJ2 I/O Control Register	TRJ2IOC	00h
0092h	Timer RJ2 Mode Register	TRJ2MR	00h
0093h	Timer RJ2 Event Pin Select Register	TRJ2ISR	00h
0094h	Timer RJ2 Register	TRJ2	FFh
0095h			FFh
0096h			
0097h			
0098h	Timer RB1 Control Register	TRB1CR	00h
0099h	Timer RB1 One-Shot Control Register	TRB1OCR	00h
009Ah	Timer RB1 I/O Control Register	TRB1IOC	00h
009Bh	Timer RB1 Mode Register	TRB1MR	00h
009Ch	Timer RB1 Prescaler Register	TRB1PRE	FFh
009Dh	Timer RB1 Secondary Register	TRB1SC	FFh
009Eh	Timer RB1 Primary Register	TRB1PR	FFh
009Fh			
00A0h	UART0 Transmit/Receive Mode Register	U0MR	00h
00A1h	UART0 Bit Rate Register	U0BRG	XXh
00A2h	UART0 Transmit Buffer Register	U0TB	XXh
00A3h			XXh
00A4h	UART0 Transmit/Receive Control Register 0	U0C0	00001000b
00A5h	UART0 Transmit/Receive Control Register 1	U0C1	00000010b
00A6h	UART0 Receive Buffer Register	U0RB	XXh
00A7h			XXh
00A8h	UART2 Transmit/Receive Mode Register	U2MR	00h
00A9h	UART2 Bit Rate Register	U2BRG	XXh
00AAh	UART2 Transmit Buffer Register	U2TB	XXh
00ABh			XXh
00ACh	UART2 Transmit/Receive Control Register 0	U2C0	00001000b
00ADh	UART2 Transmit/Receive Control Register 1	U2C1	00000010b
00AEh	UART2 Receive Buffer Register	U2RB	XXh
00AFh			XXh
00B0h	UART2 Digital Filter Function Select Register	URXDF	00h
00B1h			
00B2h			
00B3h			
00B4h			
00B5h			
00B6h			
00B7h			
00B8h			
00B9h			
00BAh			
00BBh	UART2 Special Mode Register 5	U2SMR5	00h
00BCh	UART2 Special Mode Register 4	U2SMR4	00h
00BDh	UART2 Special Mode Register 3	U2SMR3	000X0X0Xb
00BEh	UART2 Special Mode Register 2	U2SMR2	X0000000b
00BFh	UART2 Special Mode Register	U2SMR	X0000000b

X: Undefined

Note:

- Blank spaces are reserved. No access is allowed.

Table 4.13 SFR Information for R8C/LA8A Group (4) (1)

Address	Register	Symbol	After Reset
00C0h	A/D Register 0	AD0	XXh
00C1h			000000XXb
00C2h	A/D Register 1	AD1	XXh
00C3h			000000XXb
00C4h	A/D Register 2	AD2	XXh
00C5h			000000XXb
00C6h	A/D Register 3	AD3	XXh
00C7h			000000XXb
00C8h	A/D Register 4	AD4	XXh
00C9h			000000XXb
00CAh	A/D Register 5	AD5	XXh
00CBh			000000XXb
00CCh	A/D Register 6	AD6	XXh
00CDh			000000XXb
00CEh	A/D Register 7	AD7	XXh
00CFh			000000XXb
00D0h			
00D1h			
00D2h			
00D3h			
00D4h	A/D Mode Register	ADMOD	00h
00D5h	A/D Input Select Register	ADINSEL	11000000b
00D6h	A/D Control Register 0	ADCON0	00h
00D7h	A/D Control Register 1	ADCON1	00h
00D8h			
00D9h			
00DAh			
00DBh			
00DCh			
00DDh	A/D Control Register 2	ADCON2	00h
00DEh			
00DFh			
00E0h	Port P0 Register	P0	XXh
00E1h	Port P1 Register	P1	XXh
00E2h	Port P0 Direction Register	PD0	00h
00E3h	Port P1 Direction Register	PD1	00h
00E4h	Port P2 Register	P2	XXh
00E5h	Port P3 Register	P3	XXh
00E6h	Port P2 Direction Register	PD2	00h
00E7h	Port P3 Direction Register	PD3	00h
00E8h	Port P4 Register	P4	XXh
00E9h	Port P5 Register	P5	XXh
00EAh	Port P4 Direction Register	PD4	00h
00EBh	Port P5 Direction Register	PD5	00h
00ECh	Port P6 Register	P6	XXh
00EDh	Port P7 Register	P7	XXh
00EEh	Port P6 Direction Register	PD6	00h
00EFh	Port P7 Direction Register	PD7	00h
00F0h	Port P8 Register	P8	XXh
00F1h	Port P9 Register	P9	XXh
00F2h	Port P8 Direction Register	PD8	00h
00F3h	Port P9 Direction Register	PD9	00h
00F4h			
00F5h			
00F6h			
00F7h			
00F8h			
00F9h			
00FAh			
00FBh			
00FCh			
00FDh			
00FEh			
00FFh			

X: Undefined

Note:

- Blank spaces are reserved. No access is allowed.

Table 4.14 SFR Information for R8C/LA8A Group (5) (1)

Address	Register	Symbol	After Reset
0100h			
0101h			
0102h			
0103h			
0104h			
0105h			
0106h			
0107h			
0108h	Timer RB0 Control Register	TRB0CR	00h
0109h	Timer RB0 One-Shot Control Register	TRB0OCR	00h
010Ah	Timer RB0 I/O Control Register	TRB0IOC	00h
010Bh	Timer RB0 Mode Register	TRB0MR	00h
010Ch	Timer RB0 Prescaler Register	TRB0PRE	FFh
010Dh	Timer RB0 Secondary Register	TRB0SC	FFh
010Eh	Timer RB0 Primary Register	TRB0PR	FFh
010Fh			
0110h	Timer RH Second Data Register / Counter Data Register	TRHSEC	XXh 00h (2)
0111h	Timer RH Minute Data Register / Compare Data Register	TRHMIN	XXh 00h (2)
0112h	Timer RH Hour Data Register	TRHHR	00XXXXXXb 00h (2)
0113h	Timer RH Day-of-the-Week Data Register	TRHWK	00000XXXb 00h (2)
0114h	Timer RH Date Data Register	TRHDY	00XXXXXXb 00000001b (2)
0115h	Timer RH Month Data Register	TRHMON	000XXXXXb 00000001b (2)
0116h	Timer RH Year Data Register	TRHYR	XXh 00h (2)
0117h	Timer RH Control Register	TRHCR	XXX000XXb 000XX1X0b (2)
0118h	Timer RH Count Source Select Register	TRHCSR	X0001000b 0XXXXXXXb (2)
0119h	Timer RH Clock Error Correction Register	TRHADJ	XXh 00h (2)
011Ah	Timer RH Interrupt Flag Register	TRHIFR	00000XXXb 000XX000b (2)
011Bh	Timer RH Interrupt Enable Register	TRHIER	XXh 00h (2)
011Ch	Timer RH Alarm Minute Register	TRHAMN	XXh 00h (2)
011Dh	Timer RH Alarm Hour Register	TRHAHR	XXh 00h (2)
011Eh	Timer RH Alarm Day-of-the-Week Register	TRHAWK	X0000XXXb 00h (2)
011Fh	Timer RH Protect Register	TRHPRC	00h X0000000b (2)
0120h	Timer RC Mode Register	TRCMR	01001000b
0121h	Timer RC Control Register 1	TRCCR1	00h
0122h	Timer RC Interrupt Enable Register	TRCIER	01110000b
0123h	Timer RC Status Register	TRCSR	01110000b
0124h	Timer RC I/O Control Register 0	TRCIOR0	10001000b
0125h	Timer RC I/O Control Register 1	TRCIOR1	10001000b
0126h	Timer RC Counter	TRC	00h 00h
0127h			
0128h	Timer RC General Register A	TRCGRA	FFh FFh
0129h			
012Ah	Timer RC General Register B	TRCGRB	FFh FFh
012Bh			
012Ch	Timer RC General Register C	TRCGRC	FFh FFh
012Dh			
012Eh	Timer RC General Register D	TRCGRD	FFh FFh
012Fh			
0130h	Timer RC Control Register 2	TRCCR2	00011000b
0131h	Timer RC Digital Filter Function Select Register	TRCDF	00h
0132h	Timer RC Output Master Enable Register	TRCOER	01111111b
0133h	Timer RC Trigger Control Register	TRCADCR	00h
0134h			
0135h			
0136h			
0137h			
0138h			
0139h			
013Ah			
013Bh			
013Ch			
013Dh			
013Eh			
013Fh			

X: Undefined

Notes:

- Blank spaces are reserved. No access is allowed.
- This is the reset value after reset by RTCRST bit in TRHCR register.

Table 4.15 SFR Information for R8C/LA8A Group (6) (1)

Address	Register	Symbol	After Reset
0140h			
0141h			
0142h			
0143h			
0144h			
0145h			
0146h			
0147h			
0148h			
0149h			
014Ah			
014Bh			
014Ch			
014Dh			
014Eh			
014Fh			
0150h			
0151h			
0152h			
0153h			
0154h			
0155h			
0156h			
0157h			
0158h			
0159h			
015Ah			
015Bh			
015Ch			
015Dh			
015Eh			
015Fh			
0160h			
0161h			
0162h			
0163h			
0164h			
0165h			
0166h			
0167h			
0168h			
0169h			
016Ah			
016Bh			
016Ch			
016Dh			
016Eh			
016Fh			
0170h			
0171h			
0172h			
0173h			
0174h			
0175h			
0176h			
0177h			
0178h			
0179h			
017Ah			
017Bh			
017Ch			
017Dh			
017Eh			
017Fh			

X: Undefined

Note:

1. Blank spaces are reserved. No access is allowed.

Table 4.16 SFR Information for R8C/LA8A Group (7) (1)

Address	Register	Symbol	After Reset
0180h	Timer RJ Pin Select Register	TRJSR	00h
0181h	Timer RB Pin Select Register	TRBSR	00h
0182h	Timer RC Pin Select Register 0	TRCPSR0	00h
0183h	Timer RC Pin Select Register 1	TRCPSR1	00h
0184h			
0185h			
0186h			
0187h			
0188h	UART0 Pin Select Register	U0SR	00h
0189h			
018Ah	UART2 Pin Select Register 0	U2SR0	00h
018Bh	UART2 Pin Select Register 1	U2SR1	00h
018Ch	SSU/IIC Pin Select Register	SSUICSR	00h
018Dh	Timer RH Second Interrupt Control Register	TRHICR	X0XXXXXXb 00000001b (3)
018Eh	INT Interrupt Input Pin Select Register	INTSR	00h
018Fh	I/O Function Pin Select Register	PINSR	00h
0190h			
0191h			
0192h			
0193h	SS Bit Counter Register	SSBR	11111000b
0194h	SS Transmit Data Register L / IIC bus Transmit Data Register (2)	SSTDR/ICDRT	FFh
0195h	SS Transmit Data Register H (2)	SSTDRH	FFh
0196h	SS Receive Data Register L / IIC bus Receive Data Register (2)	SSRDR/ICDRR	FFh
0197h	SS Receive Data Register H (2)	SSRDRH	FFh
0198h	SS Control Register H / IIC bus Control Register 1 (2)	SSCRH/ICCR1	00h
0199h	SS Control Register L / IIC bus Control Register 2 (2)	SSCRL/ICCR2	01111101b
019Ah	SS Mode Register / IIC bus Mode Register (2)	SSMR/ICMR	00010000b/00011000b
019Bh	SS Enable Register / IIC bus Interrupt Enable Register (2)	SSER/ICIER	00h
019Ch	SS Status Register / IIC bus Status Register (2)	SSSR/ICSR	00h/0000X000b
019Dh	SS Mode Register 2 / Slave Address Register (2)	SSMR2/SAR	00h
019Eh			
019Fh			
01A0h			
01A1h			
01A2h			
01A3h			
01A4h			
01A5h			
01A6h			
01A7h			
01A8h			
01A9h			
01AAh			
01ABh			
01ACh			
01ADh			
01AEh			
01AFh			
01B0h			
01B1h			
01B2h	Flash Memory Status Register	FST	10000X00b
01B3h			
01B4h	Flash Memory Control Register 0	FMR0	00h
01B5h	Flash Memory Control Register 1	FMR1	000000X0b
01B6h	Flash Memory Control Register 2	FMR2	00h
01B7h			
01B8h			
01B9h			
01BAh			
01BBh			
01BCh			
01BDh			
01BEh			
01BFh			

X: Undefined

Notes:

- Blank spaces are reserved. No access is allowed.
- Selectable by the IICSEL bit in the SSUICSR register.
- This is the reset value after reset by RTCRST bit in TRHCR register.

Table 4.17 SFR Information for R8C/LA8A Group (8) (1)

Address	Register	Symbol	After Reset
01C0h	Address Match Interrupt Register 0	RMAD0	XXh
01C1h			XXh
01C2h			0000XXXXb
01C3h	Address Match Interrupt Enable Register 0	AIER0	00h
01C4h	Address Match Interrupt Register 1	RMAD1	XXh
01C5h			XXh
01C6h			0000XXXXb
01C7h	Address Match Interrupt Enable Register 1	AIER1	00h
01C8h			
01C9h			
01CAh			
01CBh			
01CCh			
01CDh			
01CEh			
01CFh			
01D0h			
01D1h			
01D2h			
01D3h			
01D4h			
01D5h			
01D6h			
01D7h			
01D8h			
01D9h			
01DAh			
01DBh			
01DCh			
01DDh			
01DEh			
01DFh			
01E0h	Port P0 Pull-Up Control Register	P0PUR	00h
01E1h	Port P1 Pull-Up Control Register	P1PUR	00h
01E2h	Port P2 Pull-Up Control Register	P2PUR	00h
01E3h	Port P3 Pull-Up Control Register	P3PUR	00h
01E4h	Port P4 Pull-Up Control Register	P4PUR	00h
01E5h	Port P5 Pull-Up Control Register	P5PUR	00h
01E6h	Port P6 Pull-Up Control Register	P6PUR	00h
01E7h	Port P7 Pull-Up Control Register	P7PUR	00h
01E8h	Port P8 Pull-Up Control Register	P8PUR	00h
01E9h	Port P9 Pull-Up Control Register	P9PUR	00h
01EAh			
01EBh			
01ECh			
01EDh			
01EEh			
01EFh			
01F0h	Port P7 Drive Capacity Control Register	P7DRR	00h
01F1h	Port P8 Drive Capacity Control Register	P8DRR	00h
01F2h			
01F3h			
01F4h			
01F5h	Input Threshold Control Register 0	VLT0	00h
01F6h	Input Threshold Control Register 1	VLT1	00h
01F7h	Input Threshold Control Register 2	VLT2	00h
01F8h	Comparator B Control Register 0	INTCMP	00h
01F9h			
01FAh	External Input Enable Register 0	INTEN	00h
01FBh	External Input Enable Register 1	INTEN1	00h
01FCh	INT Input Filter Select Register 0	INTF	00h
01FDh	INT Input Filter Select Register 1	INTF1	00h
01FEh	Key Input Enable Register 0	KIEN	00h
01FFh	Key Input Enable Register 1	KIEN1	00h

X: Undefined

Note:

- Blank spaces are reserved. No access is allowed.

Table 4.18 SFR Information for R8C/LA8A Group (9) (1)

Address	Register	Symbol	After Reset
0200h	LCD Control Register	LCR0	00h
0201h			
0202h	LCD Option Clock Control Register	LCR2	00h
0203h	LCD Clock Control Register	LCR3	00h
0204h	LCD Display Control Register	LCR4	00h
0205h			
0206h	LCD Port Select Register 0	LSE0	00h
0207h	LCD Port Select Register 1	LSE1	00h
0208h	LCD Port Select Register 2	LSE2	00h
0209h	LCD Port Select Register 3	LSE3	00h
020Ah	LCD Port Select Register 4	LSE4	00h
020Bh	LCD Port Select Register 5	LSE5	00h
020Ch			
020Dh			
020Eh			
020Fh			
0210h	LCD Display Data Register	LRA0L	XXh
0211h		LRA1L	XXh
0212h		LRA2L	XXh
0213h		LRA3L	XXh
0214h		LRA4L	XXh
0215h		LRA5L	XXh
0216h		LRA6L	XXh
0217h		LRA7L	XXh
0218h		LRA8L	XXh
0219h		LRA9L	XXh
021Ah		LRA10L	XXh
021Bh		LRA11L	XXh
021Ch		LRA12L	XXh
021Dh		LRA13L	XXh
021Eh		LRA14L	XXh
021Fh		LRA15L	XXh
0220h		LRA16L	XXh
0221h		LRA17L	XXh
0222h		LRA18L	XXh
0223h		LRA19L	XXh
0224h		LRA20L	XXh
0225h		LRA21L	XXh
0226h		LRA22L	XXh
0227h		LRA23L	XXh
0228h		LRA24L	XXh
0229h		LRA25L	XXh
022Ah		LRA26L	XXh
022Bh		LRA27L	XXh
022Ch		LRA28L	XXh
022Dh		LRA29L	XXh
022Eh		LRA30L	XXh
022Fh		LRA31L	XXh
0230h		LRA32L	XXh
0231h		LRA33L	XXh
0232h		LRA34L	XXh
0233h		LRA35L	XXh
0234h		LRA36L	XXh
0235h		LRA37L	XXh
0236h		LRA38L	XXh
0237h		LRA39L	XXh
:			
2FFh			

X: Undefined

Note:

- Blank spaces are reserved. No access is allowed.

Table 4.19 ID Code Areas and Option Function Select Area

Address	Area Name	Symbol	After Reset
FFDBh	Option Function Select Register 2	OFS2	(Note 1)
FFDFh	ID1		(Note 2)
FFE3h	ID2		(Note 2)
FFEBh	ID3		(Note 2)
FFFh	ID4		(Note 2)
FFF3h	ID5		(Note 2)
FFF7h	ID6		(Note 2)
FFFBh	ID7		(Note 2)
FFFh	Option Function Select Register	OFS	(Note 1)

Notes:

- The option function select area is allocated in the flash memory, not in the SFRs. Set appropriate values as ROM data by a program.
Do not write additions to the option function select area. If the block including the option function select area is erased, the option function select area is set to FFh.
When blank products are shipped, the option function select area is set to FFh. It is set to the written value after written by the user.
When factory-programming products are shipped, the value of the option function select area is the value programmed by the user.
- The ID code areas are allocated in the flash memory, not in the SFRs. Set appropriate values as ROM data by a program.
Do not write additions to the ID code areas. If the block including the ID code areas is erased, the ID code areas are set to FFh.
When blank products are shipped, the ID code areas are set to FFh. They are set to the written value after written by the user.
When factory-programming products are shipped, the value of the ID code areas is the value programmed by the user.

5. Electrical Characteristics

5.1 Electrical Characteristics (R8C/LA3A Group and R8C/LA5A Group)

5.1.1 Absolute Maximum Ratings

Table 5.1 Absolute Maximum Ratings

Symbol	Parameter		Condition	Rated Value	Unit
V _{cc} /AV _{cc}	Supply voltage			-0.3 to 6.5	V
V _i	Input voltage	XIN	XIN-XOUT oscillation on (oscillation buffer ON) ⁽¹⁾	-0.3 to 1.9	V
		XIN	XIN-XOUT oscillation on (oscillation buffer OFF) ⁽¹⁾	-0.3 to V _{cc} + 0.3	V
		P5_4/VL1		-0.3 to VL2 ⁽²⁾	V
		P5_5/VL2		VL1 to VL3	V
		P5_6/VL3		VL2 to 6.5	V
		Other pins		-0.3 to V _{cc} + 0.3	V
V _o	Output voltage	XOUT	XIN-XOUT oscillation on (oscillation buffer ON) ⁽¹⁾	-0.3 to 1.9	V
		XOUT	XIN-XOUT oscillation on (oscillation buffer OFF) ⁽¹⁾	-0.3 to V _{cc} + 0.3	V
		COM0 to COM3		-0.3 to VL3	V
		SEG0 to SEG26		-0.3 to VL3	V
		Other pins		-0.3 to V _{cc} + 0.3	V
P _d	Power dissipation		-40 °C ≤ T _{opr} ≤ 85 °C	500	mW
T _{opr}	Operating ambient temperature			-20 to 85 (N version)/ -40 to 85 (D version)	°C
T _{stg}	Storage temperature			-65 to 150	°C

Notes:

- For the register settings for each operation, refer to **7. I/O Ports** and **9. Clock Generation Circuit** in the User's Manual: Hardware.
- The VL1 voltage should be VCC or below.

5.1.2 Recommended Operating Conditions

Table 5.2 Recommended Operating Conditions
(V_{CC} = 1.8 to 5.5 V and T_{opr} = -20 to 85 °C (N version)/ -40 to 85 °C (D version), unless otherwise specified.)

Symbol	Parameter			Conditions	Standard			Unit		
					Min.	Typ.	Max.			
V _{CC} /AV _{CC}	Supply voltage				1.8	-	5.5	V		
V _{SS} /AV _{SS}	Supply voltage				-	0	-	V		
V _{IH}	Input "H" voltage	Other than CMOS input		4.0 V ≤ V _{CC} ≤ 5.5 V	0.8 V _{CC}	-	V _{CC}	V		
				2.7 V ≤ V _{CC} < 4.0 V	0.8 V _{CC}	-	V _{CC}	V		
				1.8 V ≤ V _{CC} < 2.7 V	0.9 V _{CC}	-	V _{CC}	V		
		CMOS input	Input level switching function (I/O port)	Input level selection : 0.35 V _{CC}	4.0 V ≤ V _{CC} ≤ 5.5 V	0.5 V _{CC}	-	V _{CC}	V	
					2.7 V ≤ V _{CC} < 4.0 V	0.55 V _{CC}	-	V _{CC}	V	
					1.8 V ≤ V _{CC} < 2.7 V	0.65 V _{CC}	-	V _{CC}	V	
				Input level selection : 0.5 V _{CC}	4.0 V ≤ V _{CC} ≤ 5.5 V	0.65 V _{CC}	-	V _{CC}	V	
					2.7 V ≤ V _{CC} < 4.0 V	0.7 V _{CC}	-	V _{CC}	V	
					1.8 V ≤ V _{CC} < 2.7 V	0.8 V _{CC}	-	V _{CC}	V	
				Input level selection : 0.7 V _{CC}	4.0 V ≤ V _{CC} ≤ 5.5 V	0.85 V _{CC}	-	V _{CC}	V	
					2.7 V ≤ V _{CC} < 4.0 V	0.85 V _{CC}	-	V _{CC}	V	
					1.8 V ≤ V _{CC} < 2.7 V	0.85 V _{CC}	-	V _{CC}	V	
V _{IL}	Input "L" voltage	Other than CMOS input		4.0 V ≤ V _{CC} ≤ 5.5 V	0	-	0.2 V _{CC}	V		
				2.7 V ≤ V _{CC} < 4.0 V	0	-	0.2 V _{CC}	V		
				1.8 V ≤ V _{CC} < 2.7 V	0	-	0.05 V _{CC}	V		
		CMOS input	Input level switching function (I/O port)	Input level selection : 0.35 V _{CC}	4.0 V ≤ V _{CC} ≤ 5.5 V	0	-	0.2 V _{CC}	V	
					2.7 V ≤ V _{CC} < 4.0 V	0	-	0.2 V _{CC}	V	
					1.8 V ≤ V _{CC} < 2.7 V	0	-	0.2 V _{CC}	V	
				Input level selection : 0.5 V _{CC}	4.0 V ≤ V _{CC} ≤ 5.5 V	0	-	0.4 V _{CC}	V	
					2.7 V ≤ V _{CC} < 4.0 V	0	-	0.3 V _{CC}	V	
					1.8 V ≤ V _{CC} < 2.7 V	0	-	0.2 V _{CC}	V	
				Input level selection : 0.7 V _{CC}	4.0 V ≤ V _{CC} ≤ 5.5 V	0	-	0.55 V _{CC}	V	
					2.7 V ≤ V _{CC} < 4.0 V	0	-	0.45 V _{CC}	V	
					1.8 V ≤ V _{CC} < 2.7 V	0	-	0.35 V _{CC}	V	
		I _{OH(sum)}	Peak sum output "H" current	Sum of all pins I _{OH(peak)}			-	-	-160	mA
		I _{OH(sum)}	Average sum output "H" current	Sum of all pins I _{OH(avg)}			-	-	-80	mA
		I _{OH(peak)}	Peak output "H" current	Port P8 (2)			-	-	-40	mA
Other pins					-	-	-10	mA		
I _{OH(avg)}	Average output "H" current (1)	Port P8 (2)			-	-	-20	mA		
		Other pins			-	-	-5	mA		
I _{OL(sum)}	Peak sum output "L" current	Sum of all pins I _{OL(peak)}			-	-	160	mA		
I _{OL(sum)}	Average sum output "L" current	Sum of all pins I _{OL(avg)}			-	-	80	mA		
I _{OL(peak)}	Peak output "L" current	Port P8 (2)			-	-	40	mA		
		Other pins			-	-	10	mA		
I _{OL(avg)}	Average output "L" current (1)	Port P8 (2)			-	-	20	mA		
		Other pins			-	-	5	mA		
f _(XIN)	XIN clock input oscillation frequency	2.7 V ≤ V _{CC} ≤ 5.5 V			2	-	20	MHz		
		1.8 V ≤ V _{CC} < 2.7 V			2	-	8	MHz		
f _(XCIN)	XCIN oscillation frequency	1.8 V ≤ V _{CC} ≤ 5.5 V			-	32.768	-	kHz		
		XCIN external clock input frequency			1.8 V ≤ V _{CC} ≤ 5.5 V	-	-	50	kHz	
f _(OCO20M)	When used as the count source for timer RC (3)	2.7 V ≤ V _{CC} ≤ 5.5 V			18.432	-	20	MHz		
f _(OCO-F)	f _(OCO-F) frequency	2.7 V ≤ V _{CC} ≤ 5.5 V			-	-	20	MHz		
		1.8 V ≤ V _{CC} < 2.7 V			-	-	8	MHz		
-	System clock frequency	2.7 V ≤ V _{CC} ≤ 5.5 V			-	-	20	MHz		
		1.8 V ≤ V _{CC} < 2.7 V			-	-	8	MHz		
f _(BCLK)	CPU clock frequency	2.7 V ≤ V _{CC} ≤ 5.5 V			0	-	20	MHz		
		1.8 V ≤ V _{CC} < 2.7 V			0	-	8	MHz		

Notes:

1. The average output current indicates the average value of current measured during 100 ms.
2. This applies when the drive capacity of the output transistor is set to High by P8DRR register. When the drive capacity is set to Low, the value of any other pin applies.
3. f_(OCO20M) can be used as the count source for timer RC in the range of V_{CC} = 2.7 V to 5.5V.

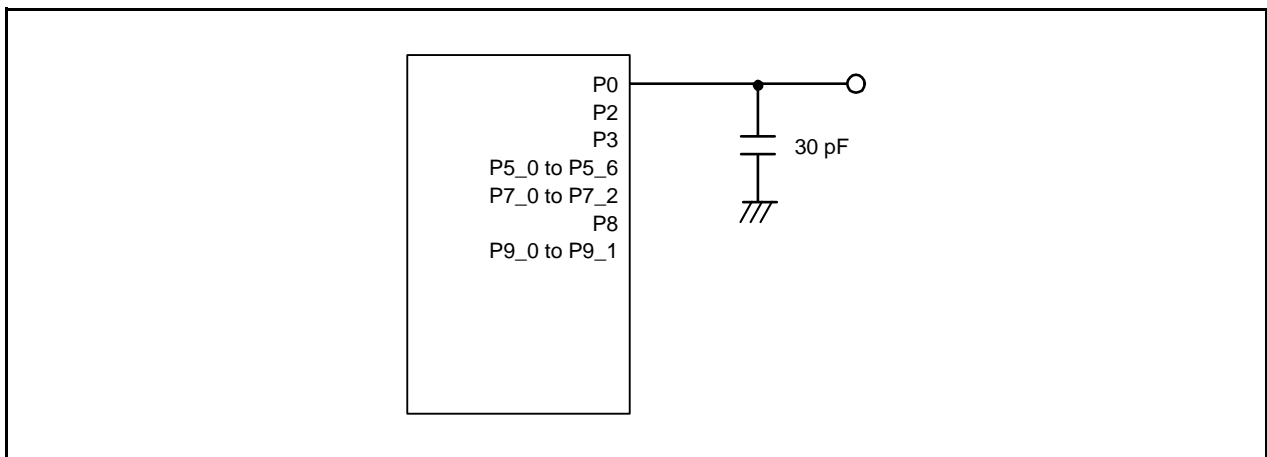

Figure 5.1 Ports P0, P2, P3, P5_0 to P5_6, P7_0 to P7_2, P8, and P9_0 to P9_1 Timing Measurement Circuit

5.1.3 Peripheral Function Characteristics

Table 5.3 A/D Converter Characteristics
($V_{CC}/AV_{CC} = V_{ref} = 1.8$ to 5.5 V, $V_{SS} = 0$ V, and $T_{opr} = -20$ to 85 °C (N version)/
 -40 to 85 °C (D version), unless otherwise specified.)

Symbol	Parameter		Conditions	Standard			Unit
				Min.	Typ.	Max.	
–	Resolution		$V_{ref} = AV_{CC}$	–	–	10	Bit
–	Absolute accuracy ⁽²⁾	10-bit mode	$V_{ref} = AV_{CC} = 5.0$ V AN0 to AN6 input	–	–	± 3	LSB
			$V_{ref} = AV_{CC} = 2.2$ V AN0 to AN6 input	–	–	± 5	LSB
			$V_{ref} = AV_{CC} = 1.8$ V AN0 to AN6 input	–	–	± 5	LSB
		8-bit mode	$V_{ref} = AV_{CC} = 5.0$ V AN0 to AN6 input	–	–	± 2	LSB
			$V_{ref} = AV_{CC} = 2.2$ V AN0 to AN6 input	–	–	± 2	LSB
			$V_{ref} = AV_{CC} = 1.8$ V AN0 to AN6 input	–	–	± 2	LSB
ϕ_{AD}	A/D conversion clock		$4.0 \leq V_{ref} = AV_{CC} \leq 5.5$ V ⁽¹⁾	1	–	20	MHz
			$3.2 \leq V_{ref} = AV_{CC} \leq 5.5$ V ⁽¹⁾	1	–	16	MHz
			$2.7 \leq V_{ref} = AV_{CC} \leq 5.5$ V ⁽¹⁾	1	–	10	MHz
			$1.8 \leq V_{ref} = AV_{CC} \leq 5.5$ V ⁽¹⁾	1	–	8	MHz
–	Tolerance level impedance			–	3	–	k Ω
t_{CONV}	Conversion time	10-bit mode	$V_{ref} = AV_{CC} = 5.0$ V, $\phi_{AD} = 20$ MHz	2.2	–	–	μ s
		8-bit mode	$V_{ref} = AV_{CC} = 5.0$ V, $\phi_{AD} = 20$ MHz	2.2	–	–	ms
t_{SAMP}	Sampling time		$\phi_{AD} = 20$ MHz	0.8	–	–	μ s
I_{Vref}	V _{ref} current		$V_{CC} = 5$ V, $XIN = f1 = \phi_{AD} = 20$ MHz	–	45	–	μ A
V_{ref}	Reference voltage			1.8	–	AV_{CC}	V
V_{IA}	Analog input voltage ⁽³⁾			0	–	V_{ref}	V
OCVREF	On-chip reference voltage		2 MHz $\leq \phi_{AD} \leq 4$ MHz	1.53	1.70	1.87	V

Notes:

1. The A/D conversion result will be undefined in wait mode, stop mode, power-off mode, when the flash memory stops, and in low-current-consumption mode. Do not perform A/D conversion in these states or transition to these states during A/D conversion.
2. This applies when the peripheral functions are stopped.
3. When the analog input voltage is over the reference voltage, the A/D conversion result will be 3FFh in 10-bit mode and FFh in 8-bit mode.

Table 5.4 Temperature Sensor Characteristics
($V_{SS} = 0$ V and $T_{opr} = -20$ to 85 °C (N version)/ -40 to 85 °C (D version), unless
otherwise specified.)

Symbol	Parameter	Conditions	Standard			Unit
			Min.	Typ.	Max.	
V_{TMP}	Temperature sensor output voltage	1.8 V $\leq V_{ref} = AV_{CC} \leq 5.5$ V $\phi_{AD} = 1.0$ MHz to 5.0 MHz Ambient temperature = 25 °C	550	600	650	mV
–	Temperature coefficient	1.8 V $\leq V_{ref} = AV_{CC} \leq 5.5$ V $\phi_{AD} = 1.0$ MHz to 5.0 MHz Ambient temperature = 25 °C	–	-2.1	–	mV/°C
–	Start-up time	1.8 V $\leq V_{ref} = AV_{CC} \leq 5.5$ V $\phi_{AD} = 1.0$ MHz to 5.0 MHz	–	–	200	μ s
I_{TMP}	Operating current	1.8 V $\leq V_{ref} = AV_{CC} \leq 5.5$ V $\phi_{AD} = 1.0$ MHz to 5.0 MHz	–	100	–	μ A

Table 5.5 Gain Amplifier Characteristics
(V_{SS} = 0 V and T_{opr} = -20 to 85 °C (N version)/ -40 to 85 °C (D version), unless otherwise specified.)

Symbol	Parameter	Conditions	Standard			Unit
			Min.	Typ.	Max.	
V _{GAIN}	Gain amplifier operating range		0.4	—	AV _{CC} - 1.0	V
φ _{AD}	A/D conversion clock		1	—	5	MHz

Table 5.6 Comparator B Characteristics
(V_{CC} = 1.8 to 5.5 V and T_{opr} = -20 to 85 °C (N version)/ -40 to 85 °C (D version), unless otherwise specified.)

Symbol	Parameter	Condition	Standard			Unit
			Min.	Typ.	Max.	
V _{ref}	IVREF1, IVREF3 input reference voltage		0	—	V _{CC} - 1.4	V
V _I	IVCMP1, IVCMP3 input voltage		-0.3	—	V _{CC} + 0.3	V
—	Offset		—	5	100	mV
t _d	Comparator output delay time ⁽¹⁾	V _I = V _{ref} ± 100 mV	—	—	1	μs
I _{CMP}	Comparator operating current	V _{CC} = 5.0 V	—	12	—	μA

Note:

1. When the digital filter is disabled.

Table 5.7 Flash Memory (Program ROM) Characteristics
(V_{CC} = 1.8 to 5.5 V and T_{opr} = 0 to 60 °C, unless otherwise specified.)

Symbol	Parameter	Conditions	Standard			Unit
			Min.	Typ.	Max.	
–	Program/erase endurance (1)		10,000 (2)	–	–	times
–	Byte program time		–	80	–	μs
–	Block erase time		–	0.12	–	s
t _d (SR-SUS)	Time delay from suspend request until suspend		–	–	0.25 + CPU clock × 3 cycles	ms
–	Time from suspend until erase restart		–	–	30 + CPU clock × 1 cycle	μs
t _d (CMDRST-READY)	Time from when command is forcibly terminated until reading is enabled		–	–	30 + CPU clock × 1 cycle	μs
–	Program, erase voltage		1.8	–	5.5	V
–	Read voltage		1.8	–	5.5	V
–	Program, erase temperature		0	–	60	°C
–	Data hold time (6)	Ambient temperature = 85 °C	10	–	–	year

Notes:

- Definition of programming/erasure endurance
 The programming and erasure endurance is defined on a per-block basis.
 If the programming and erasure endurance is n (n = 1,000), each block can be erased n times. For example, if 1,024 1-byte writes are performed to different addresses in block A, a 1 Kbyte block, and then the block is erased, the programming/erasure endurance still stands at one.
 However, the same address must not be programmed more than once per erase operation (overwriting prohibited).
- Endurance to guarantee all electrical characteristics after program and erase. (1 to Min. value can be guaranteed).
- In a system that executes multiple programming operations, the actual erasure count can be reduced by writing to sequential addresses in turn so that as much of the block as possible is used up before performing an erase operation. For example, when programming groups of 16 bytes, the effective number of rewrites can be minimized by programming up to 128 groups before erasing them all in one operation. It is also advisable to retain data on the erasure endurance of each block and limit the number of erase operations to a certain number.
- If an error occurs during block erase, attempt to execute the clear status register command, then execute the block erase command at least three times until the erase error does not occur.
- Customers desiring program/erase failure rate information should contact their Renesas technical support representative.
- The data hold time includes time that the power supply is off or the clock is not supplied.

Table 5.8 Flash Memory (Data flash Block A and Block B) Characteristics
(VCC = 1.8 to 5.5 V and Topr = -20 to 85 °C (N version)/ -40 to 85 °C (D version), unless otherwise specified.)

Symbol	Parameter	Conditions	Standard			Unit
			Min.	Typ.	Max.	
—	Program/erase endurance (1)		10,000 (2)	—	—	time s
—	Byte program time (program/erase endurance ≤ 10,000 times)		—	150	—	μs
—	Block erase time (program/erase endurance ≤ 10,000 times)		—	0.05	1	s
t _d (SR-SUS)	Time delay from suspend request until suspend		—	—	0.25 + CPU clock × 3 cycles	ms
—	Time from suspend until erase restart		—	—	30 + CPU clock × 1 cycle	μs
t _d (CMDRST-READY)	Time from when command is forcibly terminated until reading is enabled		—	—	30 + CPU clock × 1 cycle	μs
—	Program, erase voltage		1.8	—	5.5	V
—	Read voltage		1.8	—	5.5	V
—	Program, erase temperature		-20 (6)	—	85	°C
—	Data hold time (7)	Ambient temperature = 85 °C	10	—	—	year

Notes:

- Definition of programming/erasure endurance
 The programming and erasure endurance is defined on a per-block basis.
 If the programming and erasure endurance is n (n = 10,000), each block can be erased n times. For example, if 1,024 1-byte writes are performed to different addresses in block A, a 1 Kbyte block, and then the block is erased, the programming/erasure endurance still stands at one.
 However, the same address must not be programmed more than once per erase operation (overwriting prohibited).
- Endurance to guarantee all electrical characteristics after program and erase. (1 to Min. value can be guaranteed).
- In a system that executes multiple programming operations, the actual erasure count can be reduced by writing to sequential addresses in turn so that as much of the block as possible is used up before performing an erase operation. For example, when programming groups of 16 bytes, the effective number of rewrites can be minimized by programming up to 128 groups before erasing them all in one operation. In addition, averaging the erasure endurance between blocks A and B can further reduce the actual erasure endurance. It is also advisable to retain data on the erasure endurance of each block and limit the number of erase operations to a certain number.
- If an error occurs during block erase, attempt to execute the clear status register command, then execute the block erase command at least three times until the erase error does not occur.
- Customers desiring program/erase failure rate information should contact their Renesas technical support representative.
- 40 °C for D version.
- The data hold time includes time that the power supply is off or the clock is not supplied.

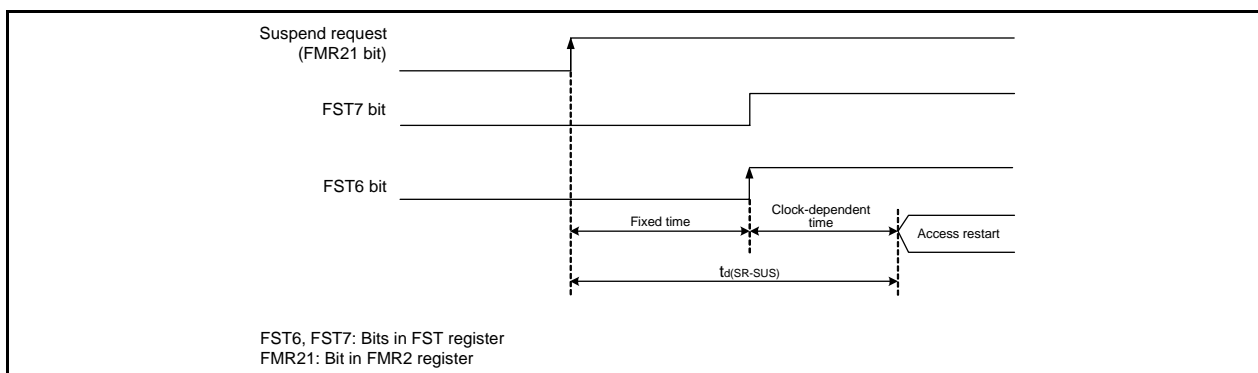

Figure 5.2 Time delay until Suspend

Table 5.9 Voltage Detection 0 Circuit Characteristics
(V_{CC} = 1.8 to 5.5 V and T_{opr} = –20 to 85 °C (N version)/ –40 to 85 °C (D version), unless otherwise specified.)

Symbol	Parameter	Condition	Standard			Unit		
			Min.	Typ.	Max.			
V _{det0}	Voltage detection level V _{det0_0} (1)		1.8	1.90	2.05	V		
	Voltage detection level V _{det0_1} (1)		2.15	2.35	2.50	V		
	Voltage detection level V _{det0_2} (1)		2.70	2.85	3.05	V		
	Voltage detection level V _{det0_3} (1)		3.55	3.80	4.05	V		
–	Voltage detection 0 circuit response time (3)	In operation	At the falling of V _{CC} from 5 V to (V _{det0_0} – 0.1) V		–	50	500	μs
		In stop mode	At the falling of V _{CC} from 5 V to (V _{det0_0} – 0.1) V		–	100	500	μs
–	Voltage detection circuit self power consumption	VCA25 = 1, V _{CC} = 5.0 V			–	1.5	–	μA
t _{d(E-A)}	Waiting time until voltage detection circuit operation starts (2)		–	–	100	–	μs	

Notes:

1. Select the voltage detection level with bits VDSEL0 and VDSEL1 in the OFS register.
2. Necessary time until the voltage detection circuit operates when setting to 1 again after setting the VCA25 bit in the VCA2 register to 0.
3. Time until the voltage monitor 0 reset is generated after the voltage passes V_{det0}.

Table 5.10 Voltage Detection 1 Circuit Characteristics
(V_{CC} = 1.8 to 5.5 V and T_{opr} = –20 to 85 °C (N version)/ –40 to 85 °C (D version), unless otherwise specified.)

Symbol	Parameter	Condition	Standard			Unit		
			Min.	Typ.	Max.			
V _{det1}	Voltage detection level V _{det1_0} (1)	At the falling of V _{CC}	2.00	2.20	2.40	V		
	Voltage detection level V _{det1_1} (1)	At the falling of V _{CC}	2.15	2.35	2.55	V		
	Voltage detection level V _{det1_2} (1)	At the falling of V _{CC}	2.30	2.50	2.70	V		
	Voltage detection level V _{det1_3} (1)	At the falling of V _{CC}	2.45	2.65	2.85	V		
	Voltage detection level V _{det1_4} (1)	At the falling of V _{CC}	2.60	2.80	3.00	V		
	Voltage detection level V _{det1_5} (1)	At the falling of V _{CC}	2.75	2.95	3.15	V		
	Voltage detection level V _{det1_6} (1)	At the falling of V _{CC}	2.85	3.10	3.40	V		
	Voltage detection level V _{det1_7} (1)	At the falling of V _{CC}	3.00	3.25	3.55	V		
	Voltage detection level V _{det1_8} (1)	At the falling of V _{CC}	3.15	3.40	3.70	V		
	Voltage detection level V _{det1_9} (1)	At the falling of V _{CC}	3.30	3.55	3.85	V		
	Voltage detection level V _{det1_A} (1)	At the falling of V _{CC}	3.45	3.70	4.00	V		
	Voltage detection level V _{det1_B} (1)	At the falling of V _{CC}	3.60	3.85	4.15	V		
	Voltage detection level V _{det1_C} (1)	At the falling of V _{CC}	3.75	4.00	4.30	V		
	Voltage detection level V _{det1_D} (1)	At the falling of V _{CC}	3.90	4.15	4.45	V		
	Voltage detection level V _{det1_E} (1)	At the falling of V _{CC}	4.05	4.30	4.60	V		
	Voltage detection level V _{det1_F} (1)	At the falling of V _{CC}	4.20	4.45	4.75	V		
–	Hysteresis width at the rising of V _{CC} in voltage detection 1 circuit	V _{det1_0} to V _{det1_5} selected	–	0.07	–	V		
		V _{det1_6} to V _{det1_F} selected	–	0.10	–	V		
–	Voltage detection 1 circuit response time (2)	In operation	At the falling of V _{CC} from 5 V to (V _{det1_0} – 0.1) V		–	60	150	μs
		In stop mode	At the falling of V _{CC} from 5 V to (V _{det1_0} – 0.1) V		–	250	500	μs
–	Voltage detection circuit self power consumption	VCA26 = 1, V _{CC} = 5.0 V			–	1.7	–	μA
t _{d(E-A)}	Waiting time until voltage detection circuit operation starts (3)		–	–	100	–	μs	

Notes:

1. Select the voltage detection level with bits VD1S0 to VD1S3 in the VD1LS register.
2. Time until the voltage monitor 1 interrupt request is generated after the voltage passes V_{det1}.
3. Necessary time until the voltage detection circuit operates when setting to 1 again after setting the VCA26 bit in the VCA2 register to 0.

Table 5.11 Voltage Detection 2 Circuit Characteristics
($V_{CC} = 1.8$ to 5.5 V and $T_{opr} = -20$ to 85 °C (N version)/ -40 to 85 °C (D version), unless otherwise specified.)

Symbol	Parameter	Condition	Standard			Unit	
			Min.	Typ.	Max.		
V_{det2}	Voltage detection level V_{det2_0} (1)	At the falling of V_{CC}	3.70	4.0	4.30	V	
–	Hysteresis width at the rising of V_{CC} in voltage detection 2 circuit		–	0.10	–	V	
–	Voltage detection 2 circuit response time (2)	In operation	At the falling of V_{CC} from 5 V to ($V_{det2_0} - 0.1$) V	–	20	150	μ s
–		In stop mode	At the falling of V_{CC} from 5 V to ($V_{det2_0} - 0.1$) V	–	200	500	μ s
–	Voltage detection circuit self power consumption	$V_{CA27} = 1, V_{CC} = 5.0$ V	–	1.7	–	μ A	
$t_{d(E-A)}$	Waiting time until voltage detection circuit operation starts (3)		–	–	100	μ s	

Notes:

1. The voltage detection level varies with detection targets. Select the level with the V_{CA24} bit in the V_{CA2} register.
2. Time until the voltage monitor 2 interrupt request is generated after the voltage passes V_{det2} .
3. Necessary time until the voltage detection circuit operates after setting to 1 again after setting the V_{CA27} bit in the V_{CA2} register to 0.

Table 5.12 Power-on Reset Circuit Characteristics (1)
($T_{opr} = -20$ to 85 °C (N version)/ -40 to 85 °C (D version), unless otherwise specified.)

Symbol	Parameter	Condition	Standard			Unit
			Min.	Typ.	Max.	
t_{rth}	External power V_{CC} rise gradient		0	–	50000	mV/ms

Note:

1. To use the power-on reset function, enable voltage monitor 0 reset by setting the $LVDAS$ bit in the OFS register to 0.

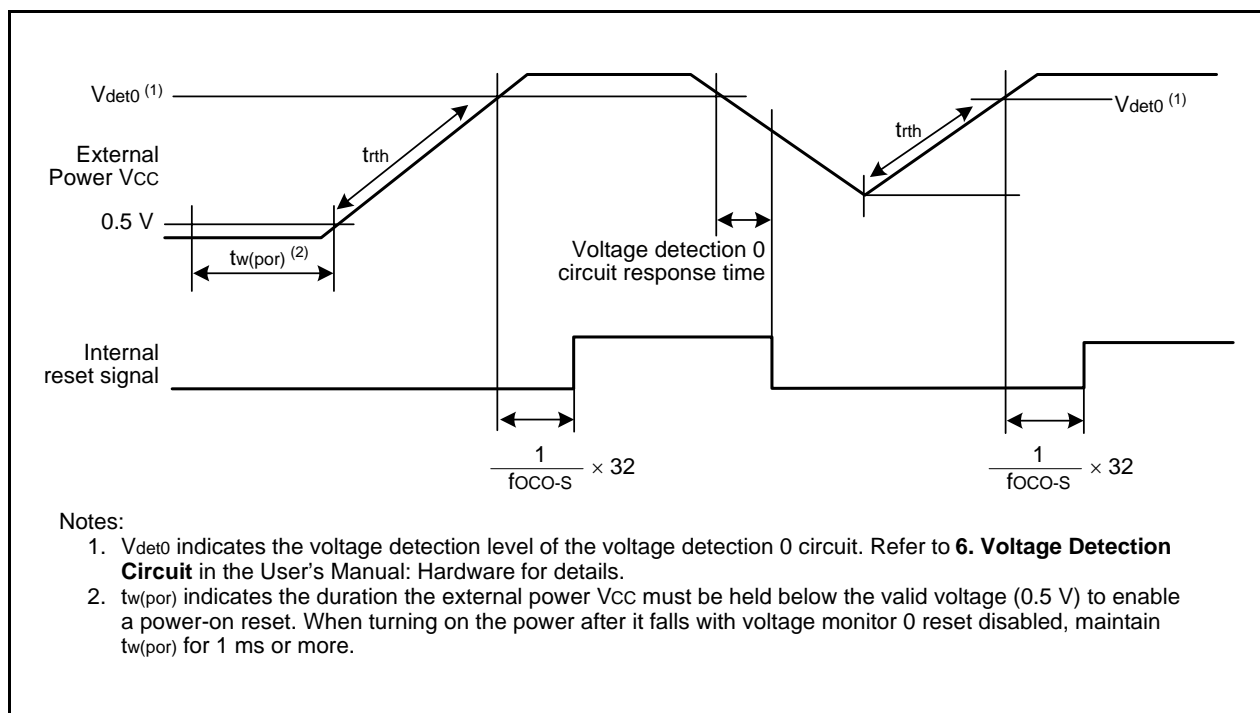

Figure 5.3 Power-on Reset Circuit Characteristics

Table 5.13 High-speed On-Chip Oscillator Circuit Characteristics
($V_{CC} = 1.8$ to 5.5 V and $T_{opr} = -20$ to 85 °C (N version)/ -40 to 85 °C (D version), unless otherwise specified.)

Symbol	Parameter	Condition	Standard			Unit
			Min.	Typ.	Max.	
–	High-speed on-chip oscillator frequency after reset	$V_{CC} = 1.8$ V to 5.5 V -20 °C $\leq T_{opr} \leq 85$ °C	19.2	20	20.8	MHz
		$V_{CC} = 1.8$ V to 5.5 V -40 °C $\leq T_{opr} \leq 85$ °C	19.0	20	21.0	MHz
–	High-speed on-chip oscillator frequency when the FRA4 register correction value is written into the FRA1 register and the FRA5 register correction value into the FRA3 register ⁽¹⁾	$V_{CC} = 1.8$ V to 5.5 V -20 °C $\leq T_{opr} \leq 85$ °C	17.694	18.432	19.169	MHz
		$V_{CC} = 1.8$ V to 5.5 V -40 °C $\leq T_{opr} \leq 85$ °C	17.510	18.432	19.353	MHz
–	Oscillation stability time		–	5	30	μ s
–	Self power consumption at oscillation	$V_{CC} = 5.0$ V, $T_{opr} = 25$ °C	–	530	–	μ A

Note:

1. This enables the setting errors of bit rates such as 9600 bps and 38400 bps to be 0% when the serial interface is used in UART mode.

Table 5.14 Low-speed On-Chip Oscillator Circuit Characteristics
($V_{CC} = 1.8$ to 5.5 V and $T_{opr} = -20$ to 85 °C (N version)/ -40 to 85 °C (D version), unless otherwise specified.)

Symbol	Parameter	Condition	Standard			Unit
			Min.	Typ.	Max.	
fOCO-S	Low-speed on-chip oscillator frequency		60	125	250	kHz
–	Oscillation stability time		–	–	35	μ s
–	Self power consumption at oscillation	$V_{CC} = 5.0$ V, $T_{opr} = 25$ °C	–	2	–	μ A
fOCO-WDT	Low-speed on-chip oscillator frequency for the watchdog timer		60	125	250	kHz
–	Oscillation stability time		–	–	35	μ s
–	Self power consumption at oscillation	$V_{CC} = 5.0$ V, $T_{opr} = 25$ °C	–	2	–	μ A

Table 5.15 Power Supply Circuit Characteristics
($V_{CC} = 1.8$ to 5.5 V, $V_{SS} = 0$ V, and $T_{opr} = 25$ °C, unless otherwise specified.)

Symbol	Parameter	Condition	Standard			Unit
			Min.	Typ.	Max.	
$t_{d(P-R)}$	Time for internal power supply stabilization during power-on ⁽¹⁾		–	–	2000	μ s

Note:

1. Waiting time until the internal power supply generation circuit stabilizes during power-on.

Table 5.16 LCD Drive Control Circuit Characteristics
(V_{CC} = 1.8 to 5.5 V, V_{SS} = 0 V, and T_{opr} = -20 to 85 °C (N version)/
-40 to 85 °C (D version), unless otherwise specified.)

Symbol	Parameter	Condition	Standard			Unit
			Min.	Typ.	Max.	
VLCD	LCD power supply voltage	VLCD = VL3	2.2	–	5.5	V
VL2	VL2 voltage		VL1	–	VL3	V
VL1	VL1 voltage		1	–	VL2 (2)	V
f(FR)	Frame frequency		50	–	180	Hz
ILCD	LCD drive control circuit current		–	(1)	–	μA

Notes:

1. Refer to Table 5.19 DC Characteristics (2), Table 5.21 DC Characteristics (4), and Table 5.23 DC Characteristics (6).
2. The VL1 voltage should be VCC or below.

Table 5.17 Power-Off Mode Characteristics
(V_{CC} = 1.8 to 5.5 V, V_{SS} = 0 V, and T_{opr} = -20 to 85 °C (N version)/
-40 to 85 °C (D version), unless otherwise specified.)

Symbol	Parameter	Condition	Standard			Unit
			Min.	Typ.	Max.	
–	Power-off mode operating supply voltage		1.8	–	5.5	V

5.1.4 DC Characteristics

Table 5.18 DC Characteristics (1) [4.0 V ≤ V_{CC} ≤ 5.5 V]
(T_{opr} = –20 to 85 °C (N version)/ –40 to 85 °C (D version), unless otherwise specified.)

Symbol	Parameter		Condition			Standard			Unit
						Min.	Typ.	Max.	
V _{OH}	Output "H" voltage		Port P8 (1)	V _{CC} = 5V	I _{OH} = –20 mA	V _{CC} – 2.0	–	V _{CC}	V
			Other pins	V _{CC} = 5V	I _{OH} = –5 mA	V _{CC} – 2.0	–	V _{CC}	V
V _{OL}	Output "L" voltage		Port P8 (1)	V _{CC} = 5V	I _{OL} = 20 mA	–	–	2.0	V
			Other pins	V _{CC} = 5V	I _{OL} = 5 mA	–	–	2.0	V
V _{T+} –V _{T–}	Hysteresis	$\overline{\text{INT0}}, \overline{\text{INT1}}, \overline{\text{INT2}},$ $\overline{\text{INT3}}, \overline{\text{INT5}}, \overline{\text{INT7}},$ $\overline{\text{KI0}}, \overline{\text{KI1}}, \overline{\text{KI2}}, \overline{\text{KI3}},$ $\overline{\text{KI4}}, \overline{\text{KI5}}, \overline{\text{KI6}}, \overline{\text{KI7}},$ TRCIOA, TRCIOB, TRCIOC, TRCIOD, TRJ0IO, TRJ1IO, TRCTRG, TRCCLK, ADTRG, RXD0, CLK0, SSI, SCL, SDA, SSO				0.05	0.5	–	V
		$\overline{\text{RESET}}, \overline{\text{WKUP0}}$				0.1	0.8	–	V
I _{IH}	Input "H" current		V _I = 5 V, V _{CC} = 5 V			–	–	5.0	μA
I _{IL}	Input "L" current		V _I = 0 V, V _{CC} = 5 V			–	–	–5.0	μA
R _{PULLUP}	Pull-up resistance		V _I = 0 V, V _{CC} = 5 V			20	40	80	kΩ
R _{I_{XIN}}	Feedback resistance	XIN				–	2.0	–	MΩ
R _{I_{XCIN}}	Feedback resistance	XCIN				–	14	–	MΩ
V _{RAM}	RAM hold voltage		During stop mode			1.8	–	–	V

Note:

1. This applies when the drive capacity of the output transistor is set to High by P8DRR register. When the drive capacity is set to Low, the value of any other pin applies.

Table 5.19 DC Characteristics (2) [4.0 V ≤ V_{CC} ≤ 5.5 V]
(T_{opr} = −20 to 85 °C (N version)/ −40 to 85 °C (D version), unless otherwise specified.)

Symbol	Parameter		Condition							Standard			Unit	
			Oscillation Circuit		On-Chip Oscillator		CPU Clock	Low-Power-Consumption Setting	Other	Min.	Typ. (3)	Max.		
			XIN (2)	XCIN	High-Speed	Low-Speed								
I _{CC}	Power supply current (1)	High-speed clock mode	20 MHz	Off	Off	125 kHz	No division	–		–	4.7	10	mA	
			16 MHz	Off	Off	125 kHz	No division	–		–	3.9	8	mA	
			10 MHz	Off	Off	125 kHz	No division	–		–	2.3	–	–	mA
			20 MHz	Off	Off	Off	No division	FMR27 = 1 MSTCR0 = BEh MSTCR1 = 3Fh	Flash memory off Program operation on RAM Module standby setting enabled	–	3.1	–	–	mA
			20 MHz	Off	Off	125 kHz	Divide-by-8	–		–	1.8	–	–	mA
			16 MHz	Off	Off	125 kHz	Divide-by-8	–		–	1.5	–	–	mA
		High-speed on-chip oscillator mode	10 MHz	Off	Off	125 kHz	Divide-by-8	–		–	1.0	–	–	mA
			Off	Off	20 MHz	125 kHz	No division	–		–	5.0	11	–	mA
			Off	Off	20 MHz	125 kHz	Divide-by-8	–		–	2.1	–	–	mA
		Low-speed on-chip oscillator mode	Off	Off	4 MHz	125 kHz	Divide-by-16	MSTCR0 = BEh MSTCR1 = 3Fh		–	0.9	–	–	mA
			Off	Off	Off	125 kHz	No division	FMR27 = 1 VCA20 = 0		–	110	320	–	μA
		Low-speed clock mode	Off	Off	Off	125 kHz	Divide-by-8	FMR27 = 1 VCA20 = 0		–	63	220	–	μA
			Off	32 kHz	Off	Off	No division	FMR27 = 1 VCA20 = 0		–	60	220	–	μA
		Wait mode	Off	32 kHz	Off	Off	No division	FMSTP = 1 VCA20 = 0	Flash memory off Program operation on RAM	–	46	–	–	μA
			Off	Off	Off	125 kHz	–	VCA27 = 0 VCA26 = 0 VCA25 = 0 VCA20 = 1	While a WAIT instruction is executed Peripheral clock operation	–	9.0	50	–	μA
		Stop mode	Off	Off	Off	125 kHz	–	VCA27 = 0 VCA26 = 0 VCA25 = 0 VCA20 = 1 CM02 = 1 CM01 = 1	While a WAIT instruction is executed Peripheral clock off	–	2.8	33	–	μA
			Off	32 kHz	Off	Off	–	VCA27 = 0 VCA26 = 0 VCA25 = 0 VCA20 = 1 CM02 = 1 CM01 = 0	While a WAIT instruction is executed Peripheral clock off Timer RH operation in real-time clock mode	LCD drive control circuit (4) When external division resistors are used	–	4.6	–	μA
			Off	32 kHz	Off	Off	–	VCA27 = 0 VCA26 = 0 VCA25 = 0 VCA20 = 1 CM02 = 1 CM01 = 1	While a WAIT instruction is executed Peripheral clock off Timer RH operation in real-time clock mode	–	2.4	–	–	μA
			Off	Off	Off	Off	–	VCA27 = 0 VCA26 = 0 VCA25 = 0 VCA20 = 1 CM10 = 1	Topr = 25 °C Peripheral clock off	–	0.5	2.2	–	μA
		Power-off mode	Off	Off	Off	Off	–	VCA27 = 0 VCA26 = 0 VCA25 = 0 VCA20 = 1 CM10 = 1	Topr = 85 °C Peripheral clock off	–	1.2	–	–	μA
			Off	Off	Off	Off	–	–	Power-off 0 Topr = 25 °C	–	0.01	0.1	–	μA
			Off	Off	Off	Off	–	–	Power-off 0 Topr = 85 °C	–	0.03	–	–	μA
			Off	32 kHz	Off	Off	–	VCA27 = 0 VCA26 = 0 VCA25 = 0 CM10 = 1	Power-off 2 Topr = 25 °C	–	1.8	6.4	–	μA
			Off	32 kHz	Off	Off	–	VCA27 = 0 VCA26 = 0 VCA25 = 0 VCA20 = 1 CM10 = 1	Power-off 2 Topr = 85 °C	–	2.7	–	–	μA

Notes:

- V_{CC} = 4.0 V to 5.5 V, single chip mode, output pins are open, and other pins are V_{SS}.
- XIN is set to square wave input.
- V_{CC} = 5.0 V
- VLCD = V_{CC}, external division resistors are used for VL3 to VL1, 1/3 bias, 1/4 duty, f(FR) = 64 Hz, SEG0 to SEG26 are selected, and segment and common output pins are open. The standard value does not include the current that flows through external division resistors.

Table 5.20 DC Characteristics (3) [2.7 V ≤ V_{CC} < 4.0 V]
(T_{opr} = -20 to 85 °C (N version)/ -40 to 85 °C (D version), unless otherwise specified.)

Symbol	Parameter		Condition		Standard			Unit
					Min.	Typ.	Max.	
V _{OH}	Output "H" voltage		Port P8 (1)	I _{OH} = -5 mA	V _{CC} - 0.5	-	V _{CC}	V
			Other pins	I _{OH} = -1 mA	V _{CC} - 0.5	-	V _{CC}	V
V _{OL}	Output "L" voltage		Port P8 (1)	I _{OL} = 5 mA	-	-	0.5	V
			Other pins	I _{OL} = 1 mA	-	-	0.5	V
V _{T+} -V _{T-}	Hysteresis	$\overline{\text{INT0}}, \overline{\text{INT1}}, \overline{\text{INT2}},$ $\overline{\text{INT3}}, \overline{\text{INT5}}, \overline{\text{INT7}},$ $\overline{\text{KI0}}, \overline{\text{KI1}}, \overline{\text{KI2}}, \overline{\text{KI3}},$ $\overline{\text{KI4}}, \overline{\text{KI5}}, \overline{\text{KI6}}, \overline{\text{KI7}},$ TRCIOA, TRCIOB, TRCIOC, TRCIOD, TRJ0IO, TRJ1IO, TRCTRG, TRCCLK, ADTRG, RXD0, CLK0, SSI, SCL, SDA, SSO			0.05	0.4	-	V
		$\overline{\text{RESET}}, \overline{\text{WKUP0}}$			0.1	0.8	-	V
I _{IH}	Input "H" current		V _I = 3 V, V _{CC} = 3 V		-	-	5.0	μA
I _{IL}	Input "L" current		V _I = 0 V, V _{CC} = 3 V		-	-	-5.0	μA
R _{PULLUP}	Pull-up resistance		V _I = 0 V, V _{CC} = 3 V		25	80	140	kΩ
R _{FXIN}	Feedback resistance	XIN			-	2.0	-	MΩ
R _{FXCIN}	Feedback resistance	XCIN			-	14	-	MΩ
V _{RAM}	RAM hold voltage		During stop mode		1.8	-	-	V

Note:

1. This applies when the drive capacity of the output transistor is set to High by P8DRR register. When the drive capacity is set to Low, the value of any other pin applies.

Table 5.21 DC Characteristics (4) [2.7 V ≤ Vcc < 4.0 V]
(Topr = −20 to 85 °C (N version)/ −40 to 85 °C (D version), unless otherwise specified.)

Symbol	Parameter		Condition							Standard			Unit	
			Oscillation Circuit		On-Chip Oscillator		CPU Clock	Low-Power-Consumption Setting	Other	Min.	Typ. (3)	Max.		
			XIN (2)	XCIN	High-Speed	Low-Speed								
Icc	Power supply current (1)	High-speed clock mode	20 MHz	Off	Off	125 kHz	No division	–	–	–	4.7	10	mA	
			10 MHz	Off	Off	125 kHz	No division	–	–	–	2.3	6	mA	
			20 MHz	Off	Off	Off	No division	FMR27 = 1 MSTCR0 = BEh MSTCR1 = 3Fh	Flash memory off Program operation on RAM Module standby setting enabled	–	–	2.9	–	mA
			20 MHz	Off	Off	125 kHz	Divide-by-8	–	–	–	–	1.8	–	mA
			10 MHz	Off	Off	125 kHz	Divide-by-8	–	–	–	–	1.0	–	mA
		High-speed on-chip oscillator mode	Off	Off	20 MHz	125 kHz	No division	–	–	–	–	5.0	11	mA
			Off	Off	20 MHz	125 kHz	Divide-by-8	–	–	–	–	2.1	–	mA
			Off	Off	10 MHz	125 kHz	No division	–	–	–	–	2.9	–	mA
			Off	Off	10 MHz	125 kHz	Divide-by-8	–	–	–	–	1.5	–	mA
			Off	Off	4 MHz	125 kHz	Divide-by-16	MSTCR0 = BEh MSTCR1 = 3Fh	–	–	–	0.9	–	mA
	Low-speed on-chip oscillator mode	Off	Off	Off	125 kHz	No division	FMR27 = 1 VCA20 = 0	–	–	–	106	300	μA	
		Off	Off	Off	125 kHz	Divide-by-8	FMR27 = 1 VCA20 = 0	–	–	–	54	200	μA	
	Low-speed clock mode	Off	32 kHz	Off	Off	No division	FMR27 = 1 VCA20 = 0	–	–	–	54	200	μA	
		Off	32 kHz	Off	Off	No division	FMSTP = 1 VCA20 = 0	Flash memory off Program operation on RAM	–	–	36	–	μA	
	Wait mode	Off	Off	Off	125 kHz	–	VCA27 = 0 VCA26 = 0 VCA25 = 0 VCA20 = 1	While a WAIT instruction is executed Peripheral clock operation	–	–	9.0	50	μA	
		Off	Off	Off	125 kHz	–	VCA27 = 0 VCA26 = 0 VCA25 = 0 VCA20 = 1 CM02 = 1 CM01 = 1	While a WAIT instruction is executed Peripheral clock off	–	–	2.5	31	μA	
		Off	32 kHz	Off	Off	–	VCA27 = 0 VCA26 = 0 VCA25 = 0 VCA20 = 1 CM02 = 1 CM01 = 0	While a WAIT instruction is executed Peripheral clock off Timer RH operation in real-time clock mode	LCD drive control circuit (4) When external division resistors are used	–	–	3.1	–	μA
		Off	32 kHz	Off	Off	–	VCA27 = 0 VCA26 = 0 VCA25 = 0 VCA20 = 1 CM02 = 1 CM01 = 1	While a WAIT instruction is executed Peripheral clock off Timer RH operation in real-time clock mode	–	–	1.7	–	μA	
		Off	32 kHz	Off	Off	–	VCA27 = 0 VCA26 = 0 VCA25 = 0 CM10 = 1	–	–	–	–	–	–	μA
	Stop mode	Off	Off	Off	Off	–	VCA27 = 0 VCA26 = 0 VCA25 = 0 CM10 = 1	Topr = 25 °C Peripheral clock off	–	–	0.5	2.2	μA	
Off		Off	Off	Off	–	VCA27 = 0 VCA26 = 0 VCA25 = 0 CM10 = 1	Topr = 85 °C Peripheral clock off	–	–	1.2	–	μA		
Power-off mode	Off	Off	Off	Off	–	–	Power-off 0 Topr = 25 °C	–	–	0.01	0.1	μA		
	Off	Off	Off	Off	–	–	Power-off 0 Topr = 85 °C	–	–	0.02	–	μA		
	Off	32 kHz	Off	Off	–	VCA27 = 0 VCA26 = 0 VCA25 = 0 CM10 = 1	Power-off 2 Topr = 25 °C	–	–	1.3	4.5	μA		
	Off	32 kHz	Off	Off	–	VCA27 = 0 VCA26 = 0 VCA25 = 0 CM10 = 1	Power-off 2 Topr = 85 °C	–	–	2.2	–	μA		

Notes:

- Vcc = 2.7 V to 4.0 V, single chip mode, output pins are open, and other pins are Vss.
- XIN is set to square wave input.
- Vcc = 3.0 V
- VLCD = Vcc, external division resistors are used for VL3 to VL1, 1/3 bias, 1/4 duty, f(FR) = 64 Hz, SEG0 to SEG26 are selected, and segment and common output pins are open. The standard value does not include the current that flows through external division resistors.

Table 5.22 DC Characteristics (5) [1.8 V ≤ V_{CC} < 2.7 V]
(T_{opr} = –20 to 85 °C (N version)/ –40 to 85 °C (D version), unless otherwise specified.)

Symbol	Parameter		Condition		Standard			Unit
					Min.	Typ.	Max.	
V _{OH}	Output "H" voltage		Port P8 (1)	I _{OH} = –2 mA	V _{CC} – 0.5	–	V _{CC}	V
			Other pins	I _{OH} = –1 mA	V _{CC} – 0.5	–	V _{CC}	V
V _{OL}	Output "L" voltage		Port P8 (1)	I _{OL} = 2 mA	–	–	0.5	V
			Other pins	I _{OL} = 1 mA	–	–	0.5	V
V _{T+} –V _{T-}	Hysteresis	$\overline{\text{INT0}}, \overline{\text{INT1}}, \overline{\text{INT2}},$ $\overline{\text{INT3}}, \overline{\text{INT5}}, \overline{\text{INT7}},$ $\overline{\text{KI0}}, \overline{\text{KI1}}, \overline{\text{KI2}}, \overline{\text{KI3}},$ $\overline{\text{KI4}}, \overline{\text{KI5}}, \overline{\text{KI6}}, \overline{\text{KI7}},$ TRCIOA, TRCIOB, TRCIOC, TRCIOD, TRJ0IO, TRJ1IO, TRCTRG, TRCCLK, ADTRG, RXD0, CLK0, SSI, SCL, SDA, SSO			0.05	0.4	–	V
		$\overline{\text{RESET}}, \overline{\text{WKUP0}}$			0.1	0.8	–	V
I _{IH}	Input "H" current		V _I = 1.8 V, V _{CC} = 1.8 V		–	–	4.0	μA
I _{IL}	Input "L" current		V _I = 0 V, V _{CC} = 1.8 V		–	–	–4.0	μA
R _{PULLUP}	Pull-up resistance		V _I = 0 V, V _{CC} = 1.8 V		85	220	500	kΩ
R _{FXIN}	Feedback resistance	XIN			–	2.0	–	MΩ
R _{FXCIN}	Feedback resistance	XCIN			–	14	–	MΩ
V _{RAM}	RAM hold voltage		During stop mode		1.8	–	–	V

Note:

1. This applies when the drive capacity of the output transistor is set to High by P8DRR register. When the drive capacity is set to Low, the value of any other pin applies.

Table 5.23 DC Characteristics (6) [$1.8\text{ V} \leq V_{CC} < 2.7\text{ V}$]
($T_{opr} = -20\text{ to }85\text{ }^{\circ}\text{C}$ (N version)/ $-40\text{ to }85\text{ }^{\circ}\text{C}$ (D version), unless otherwise specified.)

Symbol	Parameter		Condition							Standard			Unit	
			Oscillation Circuit		On-Chip Oscillator		CPU Clock	Low-Power-Consumption Setting	Other	Min.	Typ. ⁽³⁾	Max.		
			XIN ⁽²⁾	XCIN	High-Speed	Low-Speed								
I _{CC}	Power supply current ⁽¹⁾	High-speed clock mode	8 MHz	Off	Off	125 kHz	No division	–	–	2.1	–	mA		
			8 MHz	Off	Off	125 kHz	Divide-by-8	–	–	0.9	–	mA		
		High-speed on-chip oscillator mode	Off	Off	5 MHz	125 kHz	No division	–	–	1.8	5	mA		
			Off	Off	5 MHz	125 kHz	Divide-by-8	–	–	1.1	–	mA		
			Off	Off	4 MHz	125 kHz	Divide-by-16	MSTCR0 = BEh MSTCR1 = 3Fh	–	–	0.9	–	mA	
		Low-speed on-chip oscillator mode	Off	Off	Off	125 kHz	No division	FMR27 = 1 VCA20 = 0	–	106	300	μA		
			Off	Off	Off	125 kHz	Divide-by-8	FMR27 = 1 VCA20 = 0	–	54	200	μA		
		Low-speed clock mode	Off	32 kHz	Off	Off	No division	FMR27 = 1 VCA20 = 0	–	54	200	μA		
			Off	32 kHz	Off	Off	No division	FMSTP = 1 VCA20 = 0	Flash memory off Program operation on RAM	–	36	–	μA	
		Wait mode	Off	Off	Off	125 kHz	–	VCA27 = 0 VCA26 = 0 VCA25 = 0 VCA20 = 1	While a WAIT instruction is executed Peripheral clock operation	–	9.0	50	μA	
			Off	Off	Off	125 kHz	–	VCA27 = 0 VCA26 = 0 VCA25 = 0 VCA20 = 1 CM02 = 1 CM01 = 1	While a WAIT instruction is executed Peripheral clock off	–	2.5	31	μA	
			Off	32 kHz	Off	Off	–	VCA27 = 0 VCA26 = 0 VCA25 = 0 VCA20 = 1 CM02 = 1 CM01 = 0	While a WAIT instruction is executed Peripheral clock off Timer RH operation in real-time clock mode	LCD drive control circuit ⁽⁴⁾ When external division resistors are used	–	2.4	–	μA
			Off	32 kHz	Off	Off	–	VCA27 = 0 VCA26 = 0 VCA25 = 0 VCA20 = 1 CM02 = 1 CM01 = 1	While a WAIT instruction is executed Peripheral clock off Timer RH operation in real-time clock mode	–	1.7	–	μA	
		Stop mode	Off	Off	Off	Off	–	VCA27 = 0 VCA26 = 0 VCA25 = 0 CM10 = 1	Topr = 25 °C Peripheral clock off	–	0.5	2.2	μA	
			Off	Off	Off	Off	–	VCA27 = 0 VCA26 = 0 VCA25 = 0 VCA20 = 1	Topr = 85 °C Peripheral clock off	–	1.2	–	μA	
		Power-off mode	Off	Off	Off	Off	–	–	Power-off 0 Topr = 25 °C	–	0.01	0.1	μA	
			Off	Off	Off	Off	–	–	Power-off 0 Topr = 85 °C	–	0.02	–	μA	
Off	32 kHz		Off	Off	–	VCA27 = 0 VCA26 = 0 VCA25 = 0 CM10 = 1	Power-off 2 Topr = 25 °C	–	1.2	4	μA			
Off	32 kHz		Off	Off	–	VCA27 = 0 VCA26 = 0 VCA25 = 0 CM10 = 1	Power-off 2 Topr = 85 °C	–	2	–	μA			

Notes:

- V_{CC} = 1.8 V to 2.7 V, single chip mode, output pins are open, and other pins are V_{SS}.
- XIN is set to square wave input.
- V_{CC} = 2.2 V
- VLCD = V_{CC}, external division resistors are used for VL3 to VL1, 1/3 bias, 1/4 duty, f(FR) = 64 Hz, SEG0 to SEG26 are selected, and segment and common output pins are open. The standard value does not include the current that flows through external division resistors.

5.1.5 AC Characteristics

Table 5.24 Timing Requirements of Synchronous Serial Communication Unit (SSU)
(V_{CC} = 1.8 to 5.5 V, V_{SS} = 0 V, and T_{opr} = -20 to 85 °C (N version)/
-40 to 85 °C (D version), unless otherwise specified.)

Symbol	Parameter		Conditions	Standard			Unit
				Min.	Typ.	Max.	
tsucyc	SSCK clock cycle time			4	-	-	tcyc (1)
tHI	SSCK clock "H" width			0.4	-	0.6	tsucyc
tLO	SSCK clock "L" width			0.4	-	0.6	tsucyc
tRISE	SSCK clock rising time	Master		-	-	1	tcyc (1)
		Slave		-	-	1	μs
tFALL	SSCK clock falling time	Master		-	-	1	tcyc (1)
		Slave		-	-	1	μs
tsu	SSO, SSI data input setup time			100	-	-	ns
tH	SSO, SSI data input hold time			1	-	-	tcyc (1)
tLEAD	\overline{SCS} setup time	Slave		1tcyc + 50	-	-	ns
tLAG	\overline{SCS} hold time	Slave		1tcyc + 50	-	-	ns
tOD	SSO, SSI data output delay time			-	-	1tcyc + 20	ns
tsa	SSI slave access time		2.7 V ≤ V _{CC} ≤ 5.5 V	-	-	1.5tcyc + 100	ns
			1.8 V ≤ V _{CC} < 2.7 V	-	-	1.5tcyc + 200	ns
tor	SSI slave out open time		2.7 V ≤ V _{CC} ≤ 5.5 V	-	-	1.5tcyc + 100	ns
			1.8 V ≤ V _{CC} < 2.7 V	-	-	1.5tcyc + 200	ns

Note:

- 1tcyc = 1/f1(s)

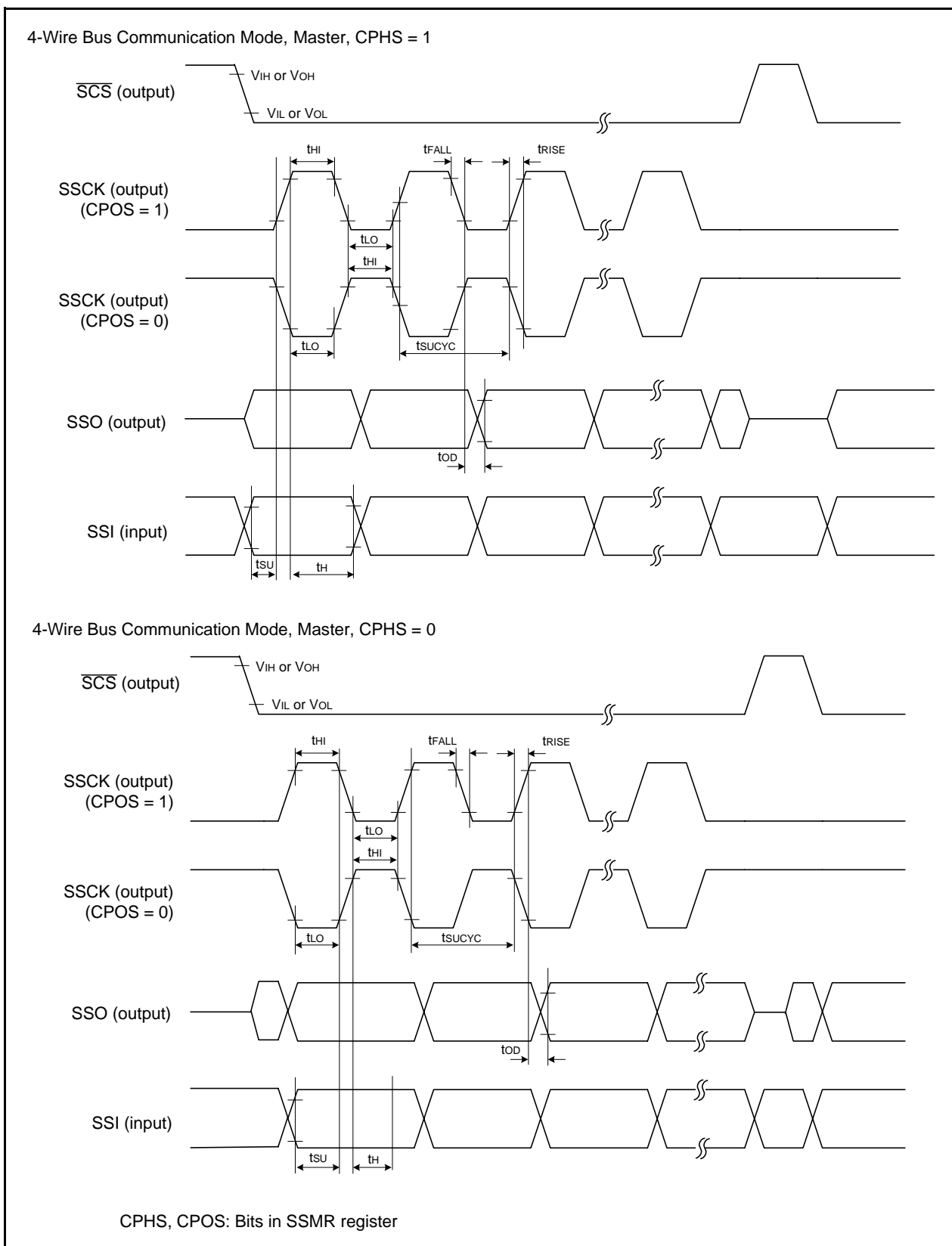

Figure 5.4 I/O Timing of Synchronous Serial Communication Unit (SSU) (Master)

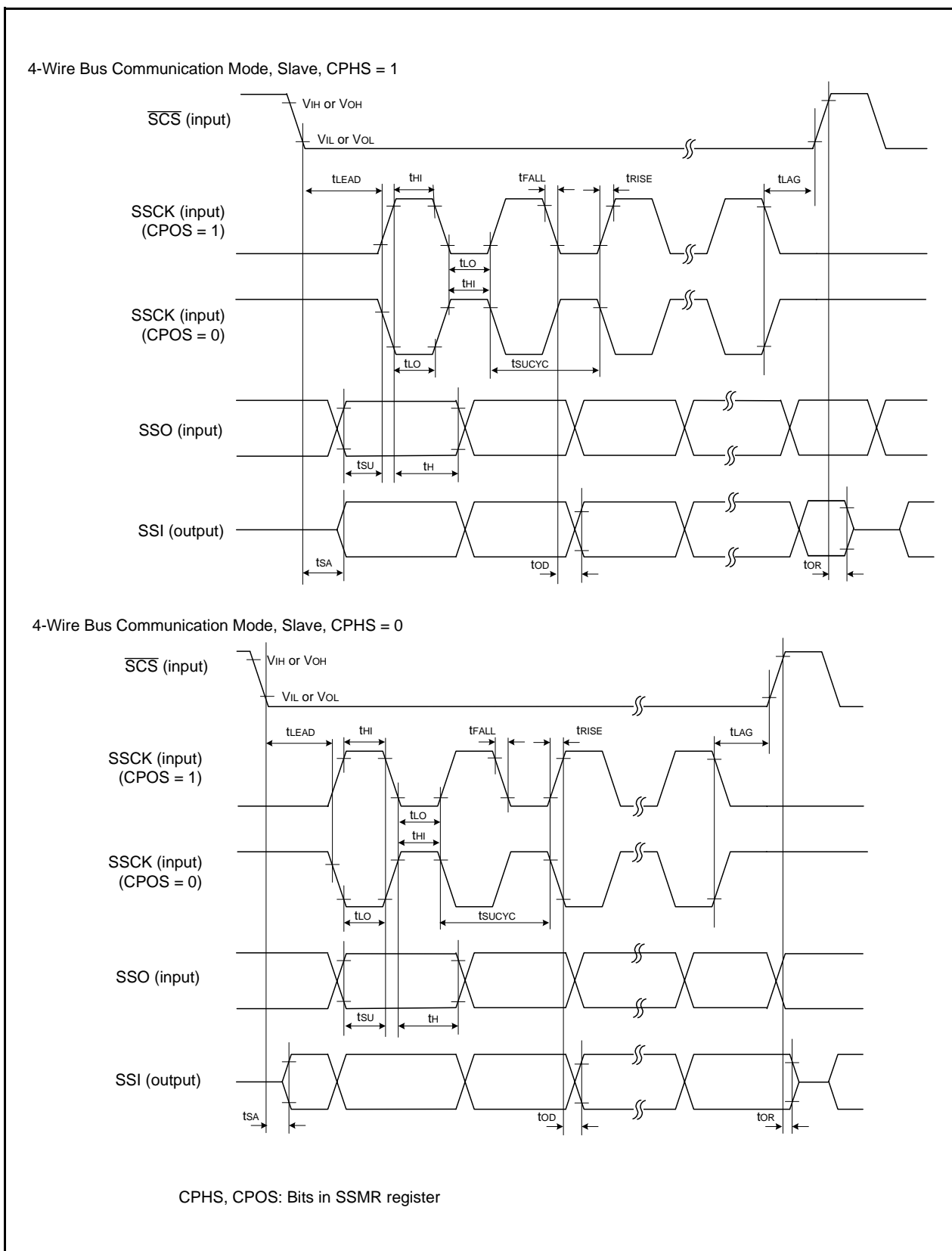

Figure 5.5 I/O Timing of Synchronous Serial Communication Unit (SSU) (Slave)

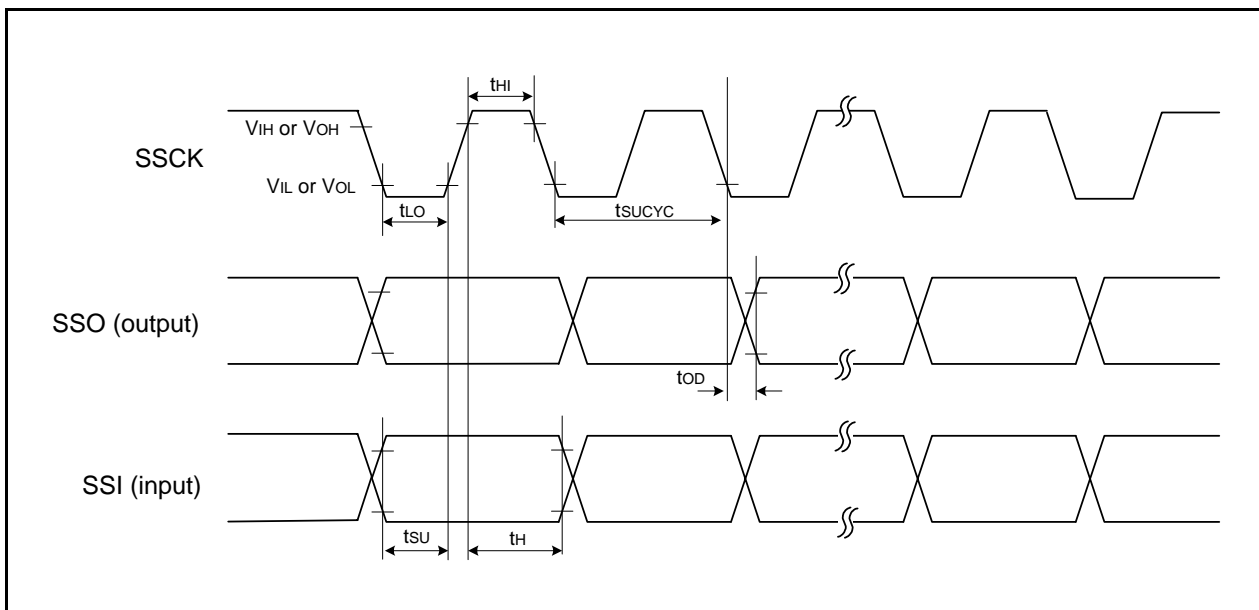

Figure 5.6 I/O Timing of Synchronous Serial Communication Unit (SSU) (Clock Synchronous Communication Mode)

Table 5.25 Timing Requirements of I²C bus Interface ⁽¹⁾
(V_{CC} = 1.8 to 5.5 V, V_{SS} = 0 V, and T_{opr} = -20 to 85 °C (N version)/ -40 to 85 °C (D version), unless otherwise specified.)

Symbol	Parameter	Condition	Standard			Unit
			Min.	Typ.	Max.	
t _{SCL}	SCL input cycle time		12tcyc + 600 ⁽¹⁾	–	–	ns
t _{SCLH}	SCL input “H” width		3tcyc + 300 ⁽¹⁾	–	–	ns
t _{SCLL}	SCL input “L” width		5tcyc + 500 ⁽¹⁾	–	–	ns
t _{sf}	SCL, SDA input fall time		–	–	300	ns
t _{SP}	SCL, SDA input spike pulse rejection time		–	–	1tcyc ⁽¹⁾	ns
t _{BUF}	SDA input bus-free time		5tcyc ⁽¹⁾	–	–	ns
t _{STAH}	Start condition input hold time		3tcyc ⁽¹⁾	–	–	ns
t _{STAS}	Retransmit start condition input setup time		3tcyc ⁽¹⁾	–	–	ns
t _{STOP}	Stop condition input setup time		3tcyc ⁽¹⁾	–	–	ns
t _{SDAS}	Data input setup time		1tcyc + 40 ⁽¹⁾	–	–	ns
t _{SDAH}	Data input hold time		10	–	–	ns

Note:

- 1tcyc = 1/f1(s)

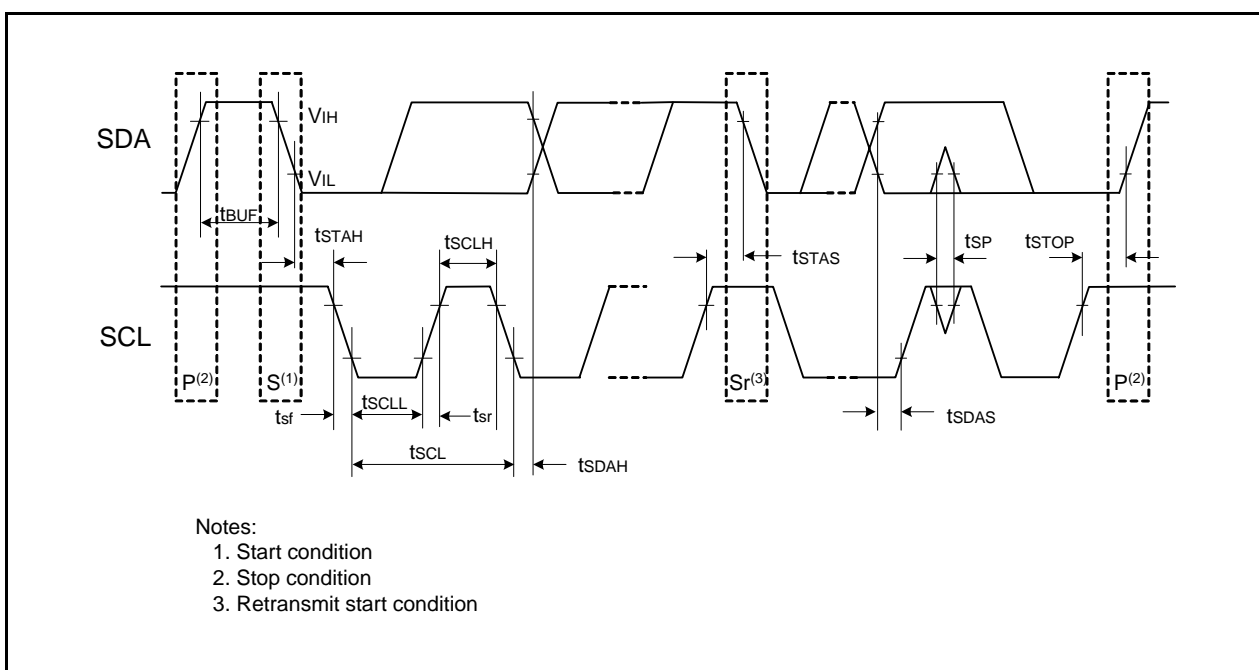

Figure 5.7 I/O Timing of I²C bus Interface

Table 5.26 Timing Requirements of External Clock Input (XIN, XCIN)
($V_{SS} = 0\text{ V}$ and $T_{opr} = -20\text{ to }85\text{ }^{\circ}\text{C}$ (N version)/ $-40\text{ to }85\text{ }^{\circ}\text{C}$ (D version), unless otherwise specified.)

Symbol	Parameter	Standard						Unit
		$V_{CC} = 2.2\text{V}, T_{opr} = 25^{\circ}\text{C}$		$V_{CC} = 3\text{V}, T_{opr} = 25^{\circ}\text{C}$		$V_{CC} = 5\text{V}, T_{opr} = 25^{\circ}\text{C}$		
		Min.	Max.	Min.	Max.	Min.	Max.	
$t_{c(XIN)}$	XIN input cycle time	200	–	50	–	50	–	ns
$t_{WH(XIN)}$	XIN input “H” width	90	–	24	–	24	–	ns
$t_{WL(XIN)}$	XIN input “L” width	90	–	24	–	24	–	ns
$t_{c(XCIN)}$	XCIN input cycle time	20	–	20	–	20	–	μs
$t_{WH(XCIN)}$	XCIN input “H” width	10	–	10	–	10	–	μs
$t_{WL(XCIN)}$	XCIN input “L” width	10	–	10	–	10	–	μs

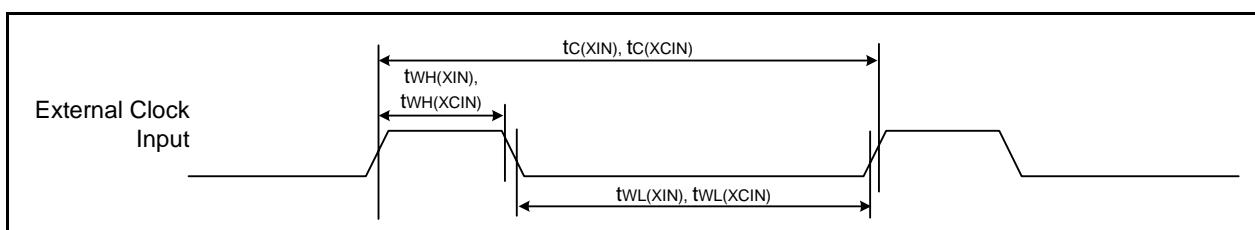

Figure 5.8 External Clock Input Timing

Table 5.27 Timing Requirements of TRJiIO (i = 0 or 1)
($V_{SS} = 0\text{ V}$ and $T_{opr} = -20\text{ to }85\text{ }^{\circ}\text{C}$ (N version)/ $-40\text{ to }85\text{ }^{\circ}\text{C}$ (D version), unless otherwise specified.)

Symbol	Parameter	Standard						Unit
		$V_{CC} = 2.2\text{V}, T_{opr} = 25^{\circ}\text{C}$		$V_{CC} = 3\text{V}, T_{opr} = 25^{\circ}\text{C}$		$V_{CC} = 5\text{V}, T_{opr} = 25^{\circ}\text{C}$		
		Min.	Max.	Min.	Max.	Min.	Max.	
$t_{c(TRJIO)}$	TRJiIO input cycle time	500	–	300	–	100	–	ns
$t_{WH(TRJIO)}$	TRJiIO input “H” width	200	–	120	–	40	–	ns
$t_{WL(TRJIO)}$	TRJiIO input “L” width	200	–	120	–	40	–	ns

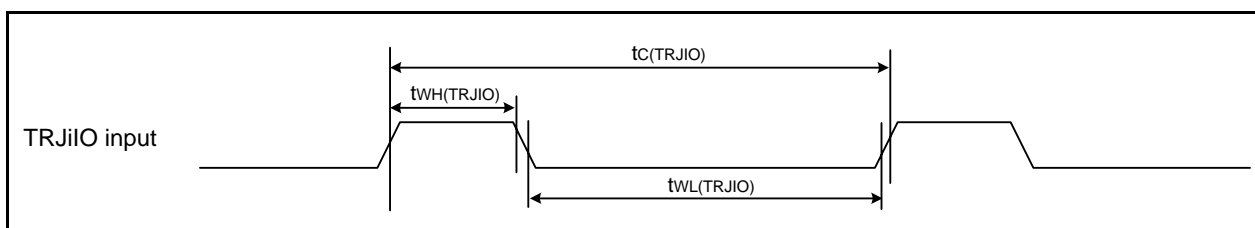

Figure 5.9 Input Timing of TRJiIO

Table 5.28 Timing Requirements of Serial Interface
($V_{SS} = 0\text{ V}$ and $T_{opr} = -20\text{ to }85\text{ }^{\circ}\text{C}$ (N version)/ $-40\text{ to }85\text{ }^{\circ}\text{C}$ (D version), unless otherwise specified.)

Symbol	Parameter	Standard						Unit
		$V_{CC} = 2.2\text{V}, T_{opr} = 25^{\circ}\text{C}$		$V_{CC} = 3\text{V}, T_{opr} = 25^{\circ}\text{C}$		$V_{CC} = 5\text{V}, T_{opr} = 25^{\circ}\text{C}$		
		Min.	Max.	Min.	Max.	Min.	Max.	
$t_{c(CK)}$	CLK0 input cycle time	800	–	300	–	200	–	ns
$t_{w(CKH)}$	CLK0 input “H” width	400	–	150	–	100	–	ns
$t_{w(CKL)}$	CLK0 input “L” width	400	–	150	–	100	–	ns
$t_{d(C-Q)}$	TXD0 output delay time	–	200	–	80	–	50	ns
$t_{h(C-Q)}$	TXD0 hold time	0	–	0	–	0	–	ns
$t_{su(D-C)}$	RXD0 input setup time	150	–	70	–	50	–	ns
$t_{h(C-D)}$	RXD0 input hold time	90	–	90	–	90	–	ns

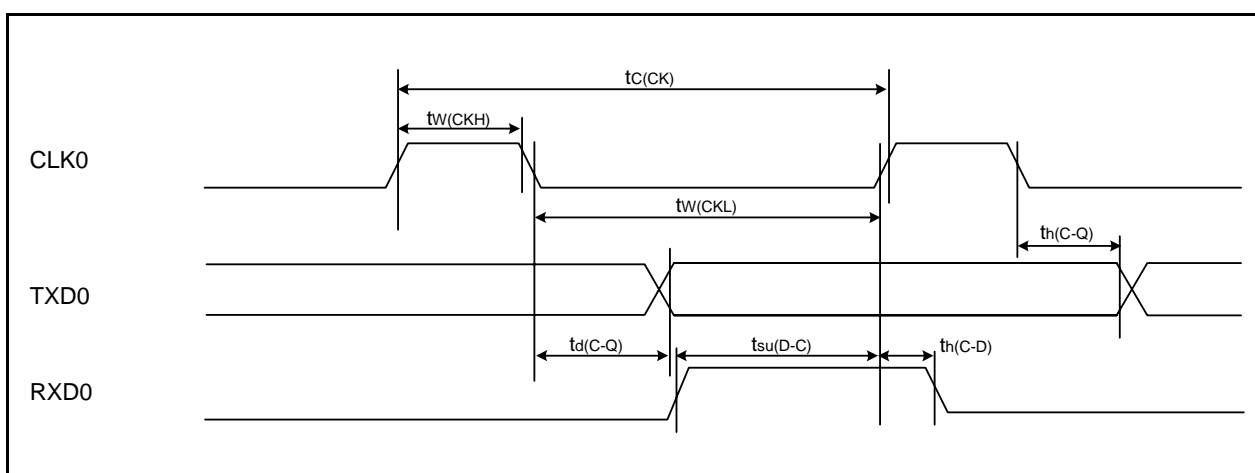

Figure 5.10 Input and Output Timing of Serial Interface

Table 5.29 Timing Requirements of External Interrupt \overline{INT}_i ($i = 0\text{ to }3, 5, 7$) and Key Input Interrupt \overline{K}_i ($i = 0\text{ to }7$)
($V_{SS} = 0\text{ V}$ and $T_{opr} = -20\text{ to }85\text{ }^{\circ}\text{C}$ (N version)/ $-40\text{ to }85\text{ }^{\circ}\text{C}$ (D version), unless otherwise specified.)

Symbol	Parameter	Standard						Unit
		$V_{CC} = 2.2\text{V}, T_{opr} = 25^{\circ}\text{C}$		$V_{CC} = 3\text{V}, T_{opr} = 25^{\circ}\text{C}$		$V_{CC} = 5\text{V}, T_{opr} = 25^{\circ}\text{C}$		
		Min.	Max.	Min.	Max.	Min.	Max.	
$t_{w(INH)}$	\overline{INT}_i input “H” width, \overline{K}_i input “H” width	1000 (1)	–	380 (1)	–	250 (1)	–	ns
$t_{w(INL)}$	\overline{INT}_i input “L” width, \overline{K}_i input “L” width	1000 (2)	–	380 (2)	–	250 (2)	–	ns

Notes:

- When selecting the digital filter by the \overline{INT}_i input filter select bit, use an \overline{INT}_i input HIGH width of either (1/digital filter clock frequency \times 3) or the minimum value of standard, whichever is greater.
- When selecting the digital filter by the \overline{INT}_i input filter select bit, use an \overline{INT}_i input LOW width of either (1/digital filter clock frequency \times 3) or the minimum value of standard, whichever is greater.

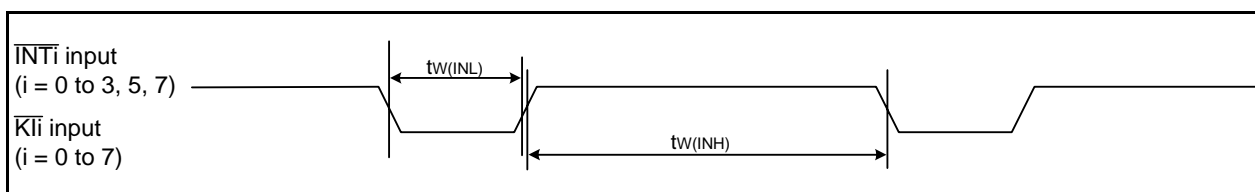

Figure 5.11 Input Timing of External Interrupt \overline{INT}_i and Key Input Interrupt \overline{K}_i

5.2 Electrical Characteristics (R8C/LA6A Group and R8C/LA8A Group)

5.2.1 Absolute Maximum Ratings

Table 5.30 Absolute Maximum Ratings

Symbol	Parameter		Condition	Rated Value	Unit
V _{CC} /AV _{CC}	Supply voltage			-0.3 to 6.5	V
V _I	Input voltage	XIN	XIN-XOUT oscillation on (oscillation buffer ON) ⁽¹⁾	-0.3 to 1.9	V
		XIN	XIN-XOUT oscillation on (oscillation buffer OFF) ⁽¹⁾	-0.3 to V _{CC} + 0.3	V
		P5_4/VL1		-0.3 to VL2 ⁽²⁾	V
		P5_5/VL2		VL1 to VL3	V
		P5_6/VL3		VL2 to 6.5	V
		Other pins		-0.3 to V _{CC} + 0.3	V
V _O	Output voltage	XOUT	XIN-XOUT oscillation on (oscillation buffer ON) ⁽¹⁾	-0.3 to 1.9	V
		XOUT	XIN-XOUT oscillation on (oscillation buffer OFF) ⁽¹⁾	-0.3 to V _{CC} + 0.3	V
		COM0 to COM3		-0.3 to VL3	V
		SEG0 to SEG39		-0.3 to VL3	V
		Other pins		-0.3 to V _{CC} + 0.3	V
P _d	Power dissipation		-40°C ≤ T _{opr} ≤ 85°C	500	mW
T _{opr}	Operating ambient temperature			-20 to 85 (N version)/ -40 to 85 (D version)	°C
T _{stg}	Storage temperature			-65 to 150	°C

Notes:

1. For the register settings for each operation, refer to **7. I/O Ports** and **9. Clock Generation Circuit** in the User's Manual: Hardware.
2. The VL1 voltage should be V_{CC} or below.

5.2.2 Recommended Operating Conditions

Table 5.31 Recommended Operating Conditions
(VCC = 1.8 to 5.5 V and Topr = -20 to 85°C (N version)/ -40 to 85°C (D version), unless otherwise specified.)

Symbol	Parameter			Conditions	Standard			Unit			
					Min.	Typ.	Max.				
VCC/AVCC	Supply voltage				1.8	-	5.5	V			
VSS/AVSS	Supply voltage				-	0	-	V			
VIH	Input "H" voltage	Other than CMOS input			4.0 V ≤ VCC ≤ 5.5 V	0.8 VCC	-	VCC	V		
					2.7 V ≤ VCC < 4.0 V	0.8 VCC	-	VCC	V		
					1.8 V ≤ VCC < 2.7 V	0.9 VCC	-	VCC	V		
		CMOS input	Input level switching function (I/O port)	Input level selection : 0.35 VCC			4.0 V ≤ VCC ≤ 5.5 V	0.5 VCC	-	VCC	V
							2.7 V ≤ VCC < 4.0 V	0.55 VCC	-	VCC	V
							1.8 V ≤ VCC < 2.7 V	0.65 VCC	-	VCC	V
				Input level selection : 0.5 VCC			4.0 V ≤ VCC ≤ 5.5 V	0.65 VCC	-	VCC	V
							2.7 V ≤ VCC < 4.0 V	0.7 VCC	-	VCC	V
							1.8 V ≤ VCC < 2.7 V	0.8 VCC	-	VCC	V
				Input level selection : 0.7 VCC			4.0 V ≤ VCC ≤ 5.5 V	0.85 VCC	-	VCC	V
							2.7 V ≤ VCC < 4.0 V	0.85 VCC	-	VCC	V
							1.8 V ≤ VCC < 2.7 V	0.85 VCC	-	VCC	V
VIL	Input "L" voltage	Other than CMOS input			4.0 V ≤ VCC ≤ 5.5 V	0	-	0.2 VCC	V		
					2.7 V ≤ VCC < 4.0 V	0	-	0.2 VCC	V		
					1.8 V ≤ VCC < 2.7 V	0	-	0.05 VCC	V		
		CMOS input	Input level switching function (I/O port)	Input level selection : 0.35 VCC			4.0 V ≤ VCC ≤ 5.5 V	0	-	0.2 VCC	V
							2.7 V ≤ VCC < 4.0 V	0	-	0.2 VCC	V
							1.8 V ≤ VCC < 2.7 V	0	-	0.2 VCC	V
				Input level selection : 0.5 VCC			4.0 V ≤ VCC ≤ 5.5 V	0	-	0.4 VCC	V
							2.7 V ≤ VCC < 4.0 V	0	-	0.3 VCC	V
							1.8 V ≤ VCC < 2.7 V	0	-	0.2 VCC	V
				Input level selection : 0.7 VCC			4.0 V ≤ VCC ≤ 5.5 V	0	-	0.55 VCC	V
							2.7 V ≤ VCC < 4.0 V	0	-	0.45 VCC	V
							1.8 V ≤ VCC < 2.7 V	0	-	0.35 VCC	V
IOH(sum)	Peak sum output "H" current	Sum of all pins IOH(peak)				-	-	-160	mA		
IOH(sum)	Average sum output "H" current	Sum of all pins IOH(avg)				-	-	-80	mA		
IOH(peak)	Peak output "H" current	Port P7_0, P7_1, P8 (2)				-	-	-40	mA		
		Other pins				-	-	-10	mA		
IOH(avg)	Average output "H" current (1)	Port P7_0, P7_1, P8 (2)				-	-	-20	mA		
		Other pins				-	-	-5	mA		
IOI(sum)	Peak sum output "L" current	Sum of all pins IOI(peak)				-	-	160	mA		
IOI(sum)	Average sum output "L" current	Sum of all pins IOI(avg)				-	-	80	mA		
IOI(peak)	Peak output "L" current	Port P7_0, P7_1, P8 (2)				-	-	40	mA		
		Other pins				-	-	10	mA		
IOI(avg)	Average output "L" current (1)	Port P7_0, P7_1, P8 (2)				-	-	20	mA		
		Other pins				-	-	5	mA		
f(XIN)	XIN clock input oscillation frequency			2.7 V ≤ VCC ≤ 5.5 V	2	-	20	MHz			
				1.8 V ≤ VCC < 2.7 V	2	-	8	MHz			
f(XCIN)	XCIN oscillation frequency			1.8 V ≤ VCC ≤ 5.5 V	-	32.768	-	kHz			
	XCIN external clock input frequency			1.8 V ≤ VCC ≤ 5.5 V	-	-	50	kHz			
fOCO20M	When used as the count source for timer RC (3)			2.7 V ≤ VCC ≤ 5.5 V	18.432	-	20	MHz			
fOCO-F	fOCO-F frequency			2.7 V ≤ VCC ≤ 5.5 V	-	-	20	MHz			
				1.8 V ≤ VCC < 2.7 V	-	-	8	MHz			
-	System clock frequency			2.7 V ≤ VCC ≤ 5.5 V	-	-	20	MHz			
				1.8 V ≤ VCC < 2.7 V	-	-	8	MHz			
f(BCLK)	CPU clock frequency			2.7 V ≤ VCC ≤ 5.5 V	0	-	20	MHz			
				1.8 V ≤ VCC < 2.7 V	0	-	8	MHz			

Notes:

- The average output current indicates the average value of current measured during 100 ms.
- This applies when the drive capacity of the output transistor is set to High by registers P7DRR and P8DRR. When the drive capacity is set to Low, the value of any other pin applies.
- fOCO20M can be used as the count source for timer RC in the range of VCC = 2.7 V to 5.5V.

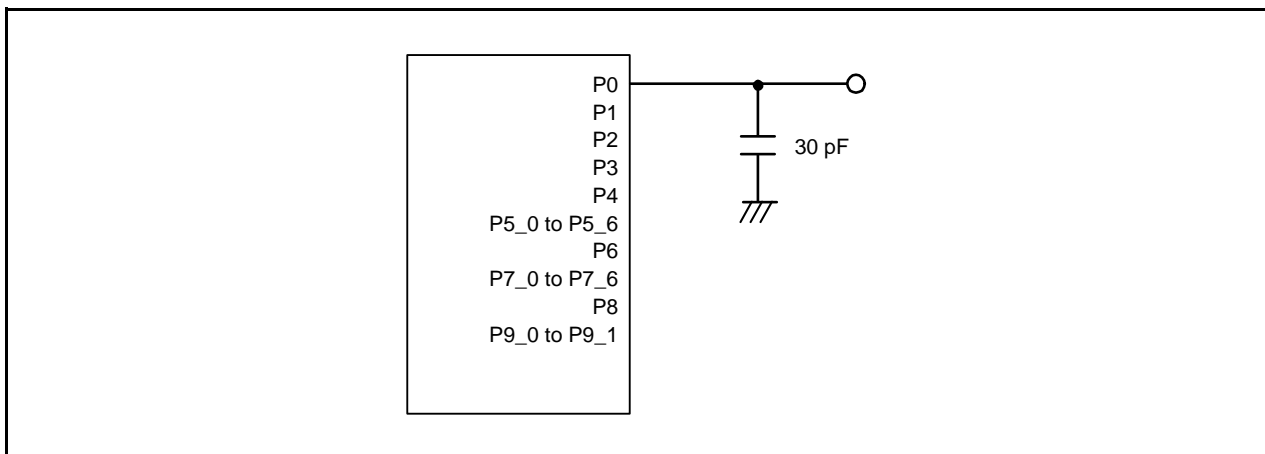

Figure 5.12 Ports P0 to P4, P5_0 to P5_6, P6, P7_0 to P7_6, P8, and P9_0 to P9_1 Timing Measurement Circuit

5.2.3 Peripheral Function Characteristics

Table 5.32 A/D Converter Characteristics
($V_{CC}/AV_{CC} = V_{ref} = 1.8$ to 5.5 V, $V_{SS} = 0$ V, and $T_{opr} = -20$ to 85°C (N version)/ -40 to 85°C (D version), unless otherwise specified.)

Symbol	Parameter		Conditions	Standard			Unit
				Min.	Typ.	Max.	
–	Resolution		$V_{ref} = AV_{CC}$	–	–	10	Bit
–	Absolute accuracy ⁽²⁾	10-bit mode	$V_{ref} = AV_{CC} = 5.0$ V AN0 to AN11 input	–	–	± 3	LSB
			$V_{ref} = AV_{CC} = 2.2$ V AN0 to AN11 input	–	–	± 5	LSB
			$V_{ref} = AV_{CC} = 1.8$ V AN0 to AN11 input	–	–	± 5	LSB
		8-bit mode	$V_{ref} = AV_{CC} = 5.0$ V AN0 to AN11 input	–	–	± 2	LSB
			$V_{ref} = AV_{CC} = 2.2$ V AN0 to AN11 input	–	–	± 2	LSB
			$V_{ref} = AV_{CC} = 1.8$ V AN0 to AN11 input	–	–	± 2	LSB
ϕ_{AD}	A/D conversion clock		$4.0 \leq V_{ref} = AV_{CC} \leq 5.5$ V ⁽¹⁾	1	–	20	MHz
			$3.2 \leq V_{ref} = AV_{CC} \leq 5.5$ V ⁽¹⁾	1	–	16	MHz
			$2.7 \leq V_{ref} = AV_{CC} \leq 5.5$ V ⁽¹⁾	1	–	10	MHz
			$1.8 \leq V_{ref} = AV_{CC} \leq 5.5$ V ⁽¹⁾	1	–	8	MHz
–	Tolerance level impedance			–	3	–	k Ω
t _{CONV}	Conversion time	10-bit mode	$V_{ref} = AV_{CC} = 5.0$ V, $\phi_{AD} = 20$ MHz	2.2	–	–	μs
		8-bit mode	$V_{ref} = AV_{CC} = 5.0$ V, $\phi_{AD} = 20$ MHz	2.2	–	–	ms
t _{SAMP}	Sampling time		$\phi_{AD} = 20$ MHz	0.8	–	–	μs
I _{Vref}	V _{ref} current		$V_{CC} = 5$ V, XIN = f1 = $\phi_{AD} = 20$ MHz	–	45	–	μA
V _{ref}	Reference voltage			1.8	–	AV _{CC}	V
V _{IA}	Analog input voltage ⁽³⁾			0	–	V _{ref}	V
OCVREF	On-chip reference voltage		$2 \text{ MHz} \leq \phi_{AD} \leq 4 \text{ MHz}$	1.53	1.70	1.87	V

Notes:

1. The A/D conversion result will be undefined in wait mode, stop mode, power-off mode, when the flash memory stops, and in low-current-consumption mode. Do not perform A/D conversion in these states or transition to these states during A/D conversion.
2. This applies when the peripheral functions are stopped.
3. When the analog input voltage is over the reference voltage, the A/D conversion result will be 3FFh in 10-bit mode and FFh in 8-bit mode.

Table 5.33 Temperature Sensor Characteristics
($V_{SS} = 0$ V and $T_{opr} = -20$ to 85°C (N version)/ -40 to 85°C (D version), unless otherwise specified.)

Symbol	Parameter	Conditions	Standard			Unit
			Min.	Typ.	Max.	
V _{TMP}	Temperature sensor output voltage	$1.8 \text{ V} \leq V_{ref} = AV_{CC} \leq 5.5 \text{ V}$ $\phi_{AD} = 1.0 \text{ MHz to } 5.0 \text{ MHz}$ Ambient temperature = 25°C	550	600	650	mV
–	Temperature coefficient	$1.8 \text{ V} \leq V_{ref} = AV_{CC} \leq 5.5 \text{ V}$ $\phi_{AD} = 1.0 \text{ MHz to } 5.0 \text{ MHz}$ Ambient temperature = 25°C	–	–2.1	–	mV/ $^{\circ}\text{C}$
–	Start-up time	$1.8 \text{ V} \leq V_{ref} = AV_{CC} \leq 5.5 \text{ V}$ $\phi_{AD} = 1.0 \text{ MHz to } 5.0 \text{ MHz}$	–	–	200	μs
I _{TMP}	Operating current	$1.8 \text{ V} \leq V_{ref} = AV_{CC} \leq 5.5 \text{ V}$ $\phi_{AD} = 1.0 \text{ MHz to } 5.0 \text{ MHz}$	–	100	–	μA

Table 5.34 Gain Amplifier Characteristics
(VSS = 0 V and Topr = -20 to 85 °C (N version)/-40 to 85 °C (D version), unless otherwise specified.)

Symbol	Parameter	Conditions	Standard			Unit
			Min.	Typ.	Max.	
VGAIN	Gain amplifier operating range		0.4	-	AVCC - 1.0	V
φAD	A/D conversion clock		1	-	5	MHz

Table 5.35 Comparator B Characteristics
(VCC = 1.8 to 5.5 V and Topr = -20 to 85°C (N version)/-40 to 85°C (D version), unless otherwise specified.)

Symbol	Parameter	Condition	Standard			Unit
			Min.	Typ.	Max.	
Vref	IVREF1, IVREF3 input reference voltage		0	-	VCC - 1.4	V
Vi	IVCMP1, IVCMP3 input voltage		-0.3	-	VCC + 0.3	V
-	Offset		-	5	100	mV
td	Comparator output delay time ⁽¹⁾	Vi = Vref ± 100 mV	-	-	1	μs
ICMP	Comparator operating current	VCC = 5.0 V	-	12	-	μA

Note:

1. When the digital filter is disabled.

Table 5.36 Flash Memory (Program ROM) Characteristics
(VCC = 1.8 to 5.5 V and Topr = 0 to 60°C, unless otherwise specified.)

Symbol	Parameter	Conditions	Standard			Unit
			Min.	Typ.	Max.	
-	Program/erase endurance ⁽¹⁾		10,000 ⁽²⁾	-	-	times
-	Byte program time		-	80	-	μs
-	Block erase time	Internal ROM Capacity: 16 KB, 32 KB, 48 KB, 64 KB	-	0.12	-	s
-		Internal ROM Capacity: 96 KB, 128 KB	-	0.2	-	s
td(SR-SUS)	Time delay from suspend request until suspend		-	-	0.25 + CPU clock × 3 cycles	ms
-	Time from suspend until erase restart		-	-	30 + CPU clock × 1 cycle	μs
td(CMDRST-READY)	Time from when command is forcibly terminated until reading is enabled		-	-	30 + CPU clock × 1 cycle	μs
-	Program, erase voltage		1.8	-	5.5	V
-	Read voltage		1.8	-	5.5	V
-	Program, erase temperature		0	-	60	°C
-	Data hold time ⁽⁶⁾	Ambient temperature = 85°C	10	-	-	year

Notes:

1. Definition of programming/erasure endurance
The programming and erasure endurance is defined on a per-block basis.
If the programming and erasure endurance is n (n = 1,000), each block can be erased n times. For example, if 1,024 1-byte writes are performed to different addresses in block A, a 1 Kbyte block, and then the block is erased, the programming/erasure endurance still stands at one.
However, the same address must not be programmed more than once per erase operation (overwriting prohibited).
2. Endurance to guarantee all electrical characteristics after program and erase. (1 to Min. value can be guaranteed).
3. In a system that executes multiple programming operations, the actual erasure count can be reduced by writing to sequential addresses in turn so that as much of the block as possible is used up before performing an erase operation. For example, when programming groups of 16 bytes, the effective number of rewrites can be minimized by programming up to 128 groups before erasing them all in one operation. It is also advisable to retain data on the erasure endurance of each block and limit the number of erase operations to a certain number.
4. If an error occurs during block erase, attempt to execute the clear status register command, then execute the block erase command at least three times until the erase error does not occur.
5. Customers desiring program/erase failure rate information should contact their Renesas technical support representative.
6. The data hold time includes time that the power supply is off or the clock is not supplied.

Table 5.37 Flash Memory (Data flash Block A and Block B) Characteristics
(V_{CC} = 1.8 to 5.5 V and T_{opr} = –20 to 85°C (N version)/ –40 to 85°C (D version), unless otherwise specified.)

Symbol	Parameter	Conditions	Standard			Unit
			Min.	Typ.	Max.	
–	Program/erase endurance (1)		10,000 (2)	–	–	times
–	Byte program time (program/erase endurance ≤ 10,000 times)		–	150	–	μs
–	Block erase time (program/erase endurance ≤ 10,000 times)	Internal ROM Capacity: 1 KB × 2	–	0.05	1	s
		Internal ROM Capacity: 2 KB × 2	–	0.055	1	s
t _d (SR-SUS)	Time delay from suspend request until suspend		–	–	0.25 + CPU clock × 3 cycles	ms
–	Time from suspend until erase restart		–	–	30 + CPU clock × 1 cycle	μs
t _d (CMDRST-READY)	Time from when command is forcibly terminated until reading is enabled		–	–	30 + CPU clock × 1 cycle	μs
–	Program, erase voltage		1.8	–	5.5	V
–	Read voltage		1.8	–	5.5	V
–	Program, erase temperature		–20 (6)	–	85	°C
–	Data hold time (7)	Ambient temperature = 85 °C	10	–	–	year

Notes:

- Definition of programming/erasure endurance
 The programming and erasure endurance is defined on a per-block basis.
 If the programming and erasure endurance is n (n = 10,000), each block can be erased n times. For example, if 1,024 1-byte writes are performed to different addresses in block A, a 1 Kbyte block, and then the block is erased, the programming/erasure endurance still stands at one.
 However, the same address must not be programmed more than once per erase operation (overwriting prohibited).
- Endurance to guarantee all electrical characteristics after program and erase. (1 to Min. value can be guaranteed).
- In a system that executes multiple programming operations, the actual erasure count can be reduced by writing to sequential addresses in turn so that as much of the block as possible is used up before performing an erase operation. For example, when programming groups of 16 bytes, the effective number of rewrites can be minimized by programming up to 128 groups before erasing them all in one operation. In addition, averaging the erasure endurance between blocks A and B can further reduce the actual erasure endurance. It is also advisable to retain data on the erasure endurance of each block and limit the number of erase operations to a certain number.
- If an error occurs during block erase, attempt to execute the clear status register command, then execute the block erase command at least three times until the erase error does not occur.
- Customers desiring program/erase failure rate information should contact their Renesas technical support representative.
- 40°C for D version.
- The data hold time includes time that the power supply is off or the clock is not supplied.

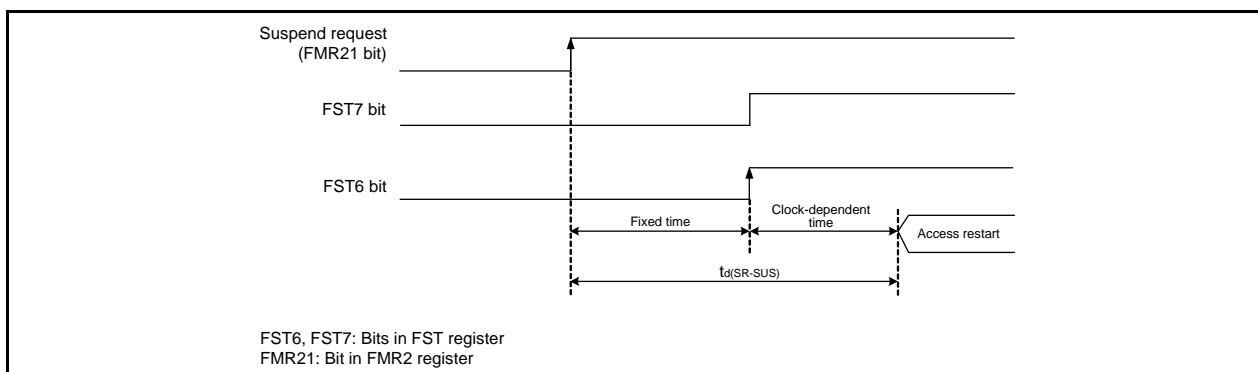

Figure 5.13 Time delay until Suspend

Table 5.38 Voltage Detection 0 Circuit Characteristics
(V_{CC} = 1.8 to 5.5 V and T_{opr} = –20 to 85°C (N version)/ –40 to 85°C (D version), unless otherwise specified.)

Symbol	Parameter	Condition	Standard			Unit		
			Min.	Typ.	Max.			
V _{det0}	Voltage detection level V _{det0_0} (1)		1.8	1.90	2.05	V		
	Voltage detection level V _{det0_1} (1)		2.15	2.35	2.50	V		
	Voltage detection level V _{det0_2} (1)		2.70	2.85	3.05	V		
	Voltage detection level V _{det0_3} (1)		3.55	3.80	4.05	V		
–	Voltage detection 0 circuit response time (3)	In operation	At the falling of V _{CC} from 5 V to (V _{det0_0} – 0.1) V		–	50	500	μs
		In stop mode	At the falling of V _{CC} from 5 V to (V _{det0_0} – 0.1) V		–	100	500	μs
–	Voltage detection circuit self power consumption	VCA25 = 1, V _{CC} = 5.0 V			–	1.5	–	μA
t _{d(E-A)}	Waiting time until voltage detection circuit operation starts (2)		–	–	100	–	μs	

Notes:

1. Select the voltage detection level with bits VDSEL0 and VDSEL1 in the OFS register.
2. Necessary time until the voltage detection circuit operates when setting to 1 again after setting the VCA25 bit in the VCA2 register to 0.
3. Time until the voltage monitor 0 reset is generated after the voltage passes V_{det0}.

Table 5.39 Voltage Detection 1 Circuit Characteristics
(V_{CC} = 1.8 to 5.5 V and T_{opr} = –20 to 85°C (N version)/ –40 to 85°C (D version), unless otherwise specified.)

Symbol	Parameter	Condition	Standard			Unit		
			Min.	Typ.	Max.			
V _{det1}	Voltage detection level V _{det1_0} (1)	At the falling of V _{CC}	2.00	2.20	2.40	V		
	Voltage detection level V _{det1_1} (1)	At the falling of V _{CC}	2.15	2.35	2.55	V		
	Voltage detection level V _{det1_2} (1)	At the falling of V _{CC}	2.30	2.50	2.70	V		
	Voltage detection level V _{det1_3} (1)	At the falling of V _{CC}	2.45	2.65	2.85	V		
	Voltage detection level V _{det1_4} (1)	At the falling of V _{CC}	2.60	2.80	3.00	V		
	Voltage detection level V _{det1_5} (1)	At the falling of V _{CC}	2.75	2.95	3.15	V		
	Voltage detection level V _{det1_6} (1)	At the falling of V _{CC}	2.85	3.10	3.40	V		
	Voltage detection level V _{det1_7} (1)	At the falling of V _{CC}	3.00	3.25	3.55	V		
	Voltage detection level V _{det1_8} (1)	At the falling of V _{CC}	3.15	3.40	3.70	V		
	Voltage detection level V _{det1_9} (1)	At the falling of V _{CC}	3.30	3.55	3.85	V		
	Voltage detection level V _{det1_A} (1)	At the falling of V _{CC}	3.45	3.70	4.00	V		
	Voltage detection level V _{det1_B} (1)	At the falling of V _{CC}	3.60	3.85	4.15	V		
	Voltage detection level V _{det1_C} (1)	At the falling of V _{CC}	3.75	4.00	4.30	V		
	Voltage detection level V _{det1_D} (1)	At the falling of V _{CC}	3.90	4.15	4.45	V		
	Voltage detection level V _{det1_E} (1)	At the falling of V _{CC}	4.05	4.30	4.60	V		
	Voltage detection level V _{det1_F} (1)	At the falling of V _{CC}	4.20	4.45	4.75	V		
–	Hysteresis width at the rising of V _{CC} in voltage detection 1 circuit	V _{det1_0} to V _{det1_5} selected	–	0.07	–	V		
		V _{det1_6} to V _{det1_F} selected	–	0.10	–	V		
–	Voltage detection 1 circuit response time (2)	In operation	At the falling of V _{CC} from 5 V to (V _{det1_0} – 0.1) V		–	60	150	μs
		In stop mode	At the falling of V _{CC} from 5 V to (V _{det1_0} – 0.1) V		–	250	500	μs
–	Voltage detection circuit self power consumption	VCA26 = 1, V _{CC} = 5.0 V			–	1.7	–	μA
t _{d(E-A)}	Waiting time until voltage detection circuit operation starts (3)		–	–	100	–	μs	

Notes:

1. Select the voltage detection level with bits VD1S0 to VD1S3 in the VD1LS register.
2. Time until the voltage monitor 1 interrupt request is generated after the voltage passes V_{det1}.
3. Necessary time until the voltage detection circuit operates when setting to 1 again after setting the VCA26 bit in the VCA2 register to 0.

Table 5.40 Voltage Detection 2 Circuit Characteristics
($V_{CC} = 1.8$ to 5.5 V and $T_{opr} = -20$ to 85°C (N version)/ -40 to 85°C (D version), unless otherwise specified.)

Symbol	Parameter	Condition	Standard			Unit
			Min.	Typ.	Max.	
V_{det2}	Voltage detection level V_{det2_0} (1)	At the falling of V_{CC}	3.70	4.0	4.30	V
–	Hysteresis width at the rising of V_{CC} in voltage detection 2 circuit		–	0.10	–	V
–	Voltage detection 2 circuit response time (2)	In operation		20	150	μs
		At the falling of V_{CC} from 5 V to ($V_{det2_0} - 0.1$) V				
–	Voltage detection 2 circuit response time (2)	In stop mode		200	500	μs
		At the falling of V_{CC} from 5 V to ($V_{det2_0} - 0.1$) V				
–	Voltage detection circuit self power consumption	$V_{CA27} = 1, V_{CC} = 5.0$ V	–	1.7	–	μA
$t_{d(E-A)}$	Waiting time until voltage detection circuit operation starts (3)		–	–	100	μs

Notes:

1. The voltage detection level varies with detection targets. Select the level with the V_{CA24} bit in the V_{CA2} register.
2. Time until the voltage monitor 2 interrupt request is generated after the voltage passes V_{det2} .
3. Necessary time until the voltage detection circuit operates after setting to 1 again after setting the V_{CA27} bit in the V_{CA2} register to 0.

Table 5.41 Power-on Reset Circuit Characteristics (1)
($T_{opr} = -20$ to 85°C (N version)/ -40 to 85°C (D version), unless otherwise specified.)

Symbol	Parameter	Condition	Standard			Unit
			Min.	Typ.	Max.	
t_{rth}	External power V_{CC} rise gradient		0	–	50000	mV/ms

Note:

1. To use the power-on reset function, enable voltage monitor 0 reset by setting the $LVDAS$ bit in the OFS register to 0.

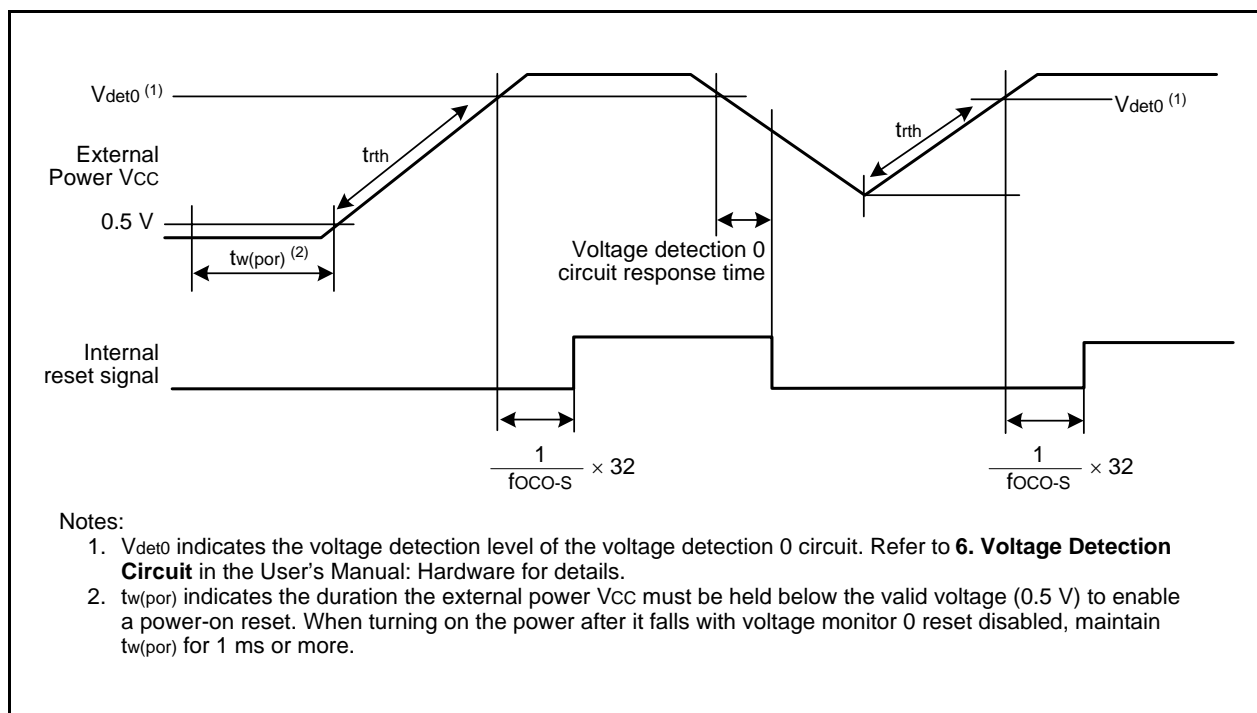

Figure 5.14 Power-on Reset Circuit Characteristics

Table 5.42 High-speed On-Chip Oscillator Circuit Characteristics
($V_{CC} = 1.8$ to 5.5 V and $T_{opr} = -20$ to 85°C (N version)/ -40 to 85°C (D version), unless otherwise specified.)

Symbol	Parameter	Condition	Standard			Unit
			Min.	Typ.	Max.	
–	High-speed on-chip oscillator frequency after reset	$V_{CC} = 1.8$ V to 5.5 V $-20^{\circ}\text{C} \leq T_{opr} \leq 85^{\circ}\text{C}$	19.2	20	20.8	MHz
		$V_{CC} = 1.8$ V to 5.5 V $-40^{\circ}\text{C} \leq T_{opr} \leq 85^{\circ}\text{C}$	19.0	20	21.0	MHz
–	High-speed on-chip oscillator frequency when the FRA4 register correction value is written into the FRA1 register and the FRA5 register correction value into the FRA3 register ⁽¹⁾	$V_{CC} = 1.8$ V to 5.5 V $-20^{\circ}\text{C} \leq T_{opr} \leq 85^{\circ}\text{C}$	17.694	18.432	19.169	MHz
		$V_{CC} = 1.8$ V to 5.5 V $-40^{\circ}\text{C} \leq T_{opr} \leq 85^{\circ}\text{C}$	17.510	18.432	19.353	MHz
–	Oscillation stability time		–	5	30	μs
–	Self power consumption at oscillation	$V_{CC} = 5.0$ V, $T_{opr} = 25^{\circ}\text{C}$	–	530	–	μA

Note:

1. This enables the setting errors of bit rates such as 9600 bps and 38400 bps to be 0% when the serial interface is used in UART mode.

Table 5.43 Low-speed On-Chip Oscillator Circuit Characteristics
($V_{CC} = 1.8$ to 5.5 V and $T_{opr} = -20$ to 85°C (N version)/ -40 to 85°C (D version), unless otherwise specified.)

Symbol	Parameter	Condition	Standard			Unit
			Min.	Typ.	Max.	
fOCO-S	Low-speed on-chip oscillator frequency		60	125	250	kHz
–	Oscillation stability time		–	–	35	μs
–	Self power consumption at oscillation	$V_{CC} = 5.0$ V, $T_{opr} = 25^{\circ}\text{C}$	–	2	–	μA
fOCO-WDT	Low-speed on-chip oscillator frequency for the watchdog timer		60	125	250	kHz
–	Oscillation stability time		–	–	35	μs
–	Self power consumption at oscillation	$V_{CC} = 5.0$ V, $T_{opr} = 25^{\circ}\text{C}$	–	2	–	μA

Table 5.44 Power Supply Circuit Characteristics
($V_{CC} = 1.8$ to 5.5 V, $V_{SS} = 0$ V, and $T_{opr} = 25^{\circ}\text{C}$, unless otherwise specified.)

Symbol	Parameter	Condition	Standard			Unit
			Min.	Typ.	Max.	
$t_{d(P-R)}$	Time for internal power supply stabilization during power-on ⁽¹⁾		–	–	2000	μs

Note:

1. Waiting time until the internal power supply generation circuit stabilizes during power-on.

Table 5.45 LCD Drive Control Circuit Characteristics
(V_{CC} = 1.8 to 5.5 V, V_{SS} = 0 V, and T_{opr} = –20 to 85°C (N version)/ –40 to 85°C (D version), unless otherwise specified.)

Symbol	Parameter	Condition	Standard			Unit
			Min.	Typ.	Max.	
VLCD	LCD power supply voltage	VLCD = VL3	2.2	–	5.5	V
VL2	VL2 voltage		VL1	–	VL3	V
VL1	VL1 voltage		1	–	VL2 (2)	V
f(FR)	Frame frequency		50	–	180	Hz
ILCD	LCD drive control circuit current		–	(1)	–	μA

Notes:

1. Refer to Table 5.48 DC Characteristics (2), Table 5.50 DC Characteristics (4), and Table 5.52 DC Characteristics (6).
2. The VL1 voltage should be VCC or below.

Table 5.46 Power-Off Mode Characteristics
(V_{CC} = 1.8 to 5.5 V, V_{SS} = 0 V, and T_{opr} = –20 to 85°C (N version)/ –40 to 85°C (D version), unless otherwise specified.)

Symbol	Parameter	Condition	Standard			Unit
			Min.	Typ.	Max.	
–	Power-off mode operating supply voltage		1.8	–	5.5	V

5.2.4 DC Characteristics

Table 5.47 DC Characteristics (1) [4.0 V ≤ V_{CC} ≤ 5.5 V]
(T_{opr} = –20 to 85°C (N version)/ –40 to 85°C (D version), unless otherwise specified.)

Symbol	Parameter		Condition			Standard			Unit
						Min.	Typ.	Max.	
V _{OH}	Output "H" voltage		Port P7_0, P7_1, P8 (1)	V _{CC} = 5V	I _{OH} = –20 mA	V _{CC} – 2.0	–	V _{CC}	V
			Other pins	V _{CC} = 5V	I _{OH} = –5 mA	V _{CC} – 2.0	–	V _{CC}	V
V _{OL}	Output "L" voltage		Port P7_0, P7_1, P8 (1)	V _{CC} = 5V	I _{OL} = 20 mA	–	–	2.0	V
			Other pins	V _{CC} = 5V	I _{OL} = 5 mA	–	–	2.0	V
V _{T+} -V _{T-}	Hysteresis	$\overline{\text{INT0}}, \overline{\text{INT1}}, \overline{\text{INT2}},$ $\overline{\text{INT3}}, \overline{\text{INT4}}, \overline{\text{INT5}},$ $\overline{\text{INT6}}, \overline{\text{INT7}},$ $\overline{\text{KI0}}, \overline{\text{KI1}}, \overline{\text{KI2}}, \overline{\text{KI3}},$ $\overline{\text{KI4}}, \overline{\text{KI5}}, \overline{\text{KI6}}, \overline{\text{KI7}},$ TRCIOA, TRCIOB, TRCIOC, TRCIOD, TRJ0IO, TRJ1IO, TRJ2IO, TRCTRG, TRCCLK, ADTRG, RXD0, RXD2, CLK0, CLK2, SSI, SCL, SDA, SSO				0.05	0.5	–	V
		$\overline{\text{RESET}}, \overline{\text{WKUP0}}$				0.1	0.8	–	V
I _{IH}	Input "H" current		V _I = 5 V, V _{CC} = 5 V			–	–	5.0	μA
I _{IL}	Input "L" current		V _I = 0 V, V _{CC} = 5 V			–	–	–5.0	μA
R _{PULLUP}	Pull-up resistance		V _I = 0 V, V _{CC} = 5 V			20	40	80	kΩ
R _{iXIN}	Feedback resistance	XIN				–	2.0	–	MΩ
R _{iXCIN}	Feedback resistance	XCIN				–	14	–	MΩ
V _{RAM}	RAM hold voltage		During stop mode			1.8	–	–	V

Note:

1. This applies when the drive capacity of the output transistor is set to High by registers P7DRR and P8DRR. When the drive capacity is set to Low, the value of any other pin applies.

**Table 5.48 DC Characteristics (2) [4.0 V ≤ Vcc ≤ 5.5 V]
(Topr = −20 to 85°C (N version)/ −40 to 85°C (D version), unless otherwise specified.)**

Symbol	Parameter		Condition							Standard			Unit	
			Oscillation Circuit		On-Chip Oscillator		CPU Clock	Low-Power-Consumption Setting	Other	Min.	Typ. (3)	Max.		
			XIN (2)	XCIN	High-Speed	Low-Speed								
Icc	Power supply current (1)	High-speed clock mode	20 MHz	Off	Off	125 kHz	No division	–		–	4.7	10	mA	
			16 MHz	Off	Off	125 kHz	No division	–		–	3.9	8	mA	
			10 MHz	Off	Off	125 kHz	No division	–		–	2.3	–	mA	
			20 MHz	Off	Off	Off	No division	FMR27 = 1 MSTCR0 = BEh MSTCR1 = 3Fh	Flash memory off Program operation on RAM Module standby setting enabled	–	3.1	–	mA	
			20 MHz	Off	Off	125 kHz	Divide-by-8	–		–	1.8	–	mA	
			16 MHz	Off	Off	125 kHz	Divide-by-8	–		–	1.5	–	mA	
		High-speed on-chip oscillator mode	10 MHz	Off	Off	125 kHz	Divide-by-8	–		–	1.0	–	mA	
			Off	Off	20 MHz	125 kHz	No division	–		–	5.0	11	mA	
			Off	Off	20 MHz	125 kHz	Divide-by-8	–		–	2.1	–	mA	
		Low-speed on-chip oscillator mode	Off	Off	4 MHz	125 kHz	Divide-by-16	MSTCR0 = BEh MSTCR1 = 3Fh		–	0.9	–	mA	
			Off	Off	Off	125 kHz	No division	FMR27 = 1 VCA20 = 0		–	110	320	μA	
		Low-speed clock mode	Off	Off	Off	125 kHz	Divide-by-8	FMR27 = 1 VCA20 = 0		–	63	220	μA	
			Off	32 kHz	Off	Off	No division	FMR27 = 1 VCA20 = 0		–	60	220	μA	
		Wait mode	Off	32 kHz	Off	Off	No division	FMSTP = 1 VCA20 = 0	Flash memory off Program operation on RAM	–	46	–	μA	
			Off	Off	Off	125 kHz	–	VCA27 = 0 VCA26 = 0 VCA25 = 0 VCA20 = 1	While a WAIT instruction is executed Peripheral clock operation	–	9.0	50	μA	
		Stop mode	Off	Off	Off	125 kHz	–	VCA27 = 0 VCA26 = 0 VCA25 = 0 VCA20 = 1 CM02 = 1 CM01 = 1	While a WAIT instruction is executed Peripheral clock off	–	2.8	33	μA	
			Off	32 kHz	Off	Off	–	VCA27 = 0 VCA26 = 0 VCA25 = 0 VCA20 = 1 CM02 = 1 CM01 = 0	While a WAIT instruction is executed Peripheral clock off Timer RH operation in real-time clock mode	LCD drive control circuit (4) When external division resistors are used	–	4.6	–	μA
			Off	32 kHz	Off	Off	–	VCA27 = 0 VCA26 = 0 VCA25 = 0 VCA20 = 1 CM02 = 1 CM01 = 1	While a WAIT instruction is executed Peripheral clock off Timer RH operation in real-time clock mode	–	2.4	–	μA	
			Off	Off	Off	Off	–	VCA27 = 0 VCA26 = 0 VCA25 = 0 VCA20 = 1 CM10 = 1	Topr = 25°C Peripheral clock off	–	0.5	2.2	μA	
		Power-off mode	Off	Off	Off	Off	–	VCA27 = 0 VCA26 = 0 VCA25 = 0 VCA20 = 1 CM10 = 1	Topr = 85°C Peripheral clock off	–	1.2	–	μA	
			Off	Off	Off	Off	–	–	Power-off 0 Topr = 25°C	–	0.01	0.1	μA	
			Off	Off	Off	Off	–	–	Power-off 0 Topr = 85°C	–	0.03	–	μA	
			Off	32 kHz	Off	Off	–	VCA27 = 0 VCA26 = 0 VCA25 = 0 CM10 = 1	Power-off 2 Topr = 25°C	–	1.8	6.4	μA	
			Off	32 kHz	Off	Off	–	VCA27 = 0 VCA26 = 0 VCA25 = 0 VCA20 = 1 CM10 = 1	Power-off 2 Topr = 85°C	–	2.7	–	μA	

Notes:

- Vcc = 4.0 V to 5.5 V, single chip mode, output pins are open, and other pins are Vss.
- XIN is set to square wave input.
- Vcc = 5.0 V
- VLCD = Vcc, external division resistors are used for VL3 to VL1, 1/3 bias, 1/4 duty, f(FR) = 64 Hz, SEG0 to SEG39 are selected, and segment and common output pins are open. The standard value does not include the current that flows through external division resistors.

Table 5.49 DC Characteristics (3) [2.7 V ≤ V_{CC} < 4.0 V]
(T_{opr} = -20 to 85°C (N version)/ -40 to 85°C (D version), unless otherwise specified.)

Symbol	Parameter		Condition		Standard			Unit
					Min.	Typ.	Max.	
V _{OH}	Output "H" voltage		Port P7_0, P7_1, P8 (1)	I _{OH} = -5 mA	V _{CC} - 0.5	-	V _{CC}	V
			Other pins	I _{OH} = -1 mA	V _{CC} - 0.5	-	V _{CC}	V
V _{OL}	Output "L" voltage		Port P7_0, P7_1, P8 (1)	I _{OL} = 5 mA	-	-	0.5	V
			Other pins	I _{OL} = 1 mA	-	-	0.5	V
V _{T+} -V _{T-}	Hysteresis	$\overline{\text{INT0}}, \overline{\text{INT1}}, \overline{\text{INT2}},$ $\overline{\text{INT3}}, \overline{\text{INT4}}, \overline{\text{INT5}},$ $\overline{\text{INT6}}, \overline{\text{INT7}},$ $\overline{\text{KI0}}, \overline{\text{KI1}}, \overline{\text{KI2}}, \overline{\text{KI3}},$ $\overline{\text{KI4}}, \overline{\text{KI5}}, \overline{\text{KI6}}, \overline{\text{KI7}},$ TRCIOA, TRCIOB, TRCIOC, TRCIOD, TRJ0IO, TRJ1IO, TRJ2IO, TRCTRG, TRCCLK, ADTRG, RXD0, RXD2, CLK0, CLK2, SSI, SCL, SDA, SSO			0.05	0.4	-	V
		RESET, WKUP0			0.1	0.8	-	V
I _{IH}	Input "H" current		V _I = 3 V, V _{CC} = 3 V		-	-	5.0	μA
I _{IL}	Input "L" current		V _I = 0 V, V _{CC} = 3 V		-	-	-5.0	μA
R _{PULLUP}	Pull-up resistance		V _I = 0 V, V _{CC} = 3 V		25	80	140	kΩ
R _{iXIN}	Feedback resistance	XIN			-	2.0	-	MΩ
R _{iXCIN}	Feedback resistance	XCIN			-	14	-	MΩ
V _{RAM}	RAM hold voltage		During stop mode		1.8	-	-	V

Note:

1. This applies when the drive capacity of the output transistor is set to High by registers P7DRR and P8DRR. When the drive capacity is set to Low, the value of any other pin applies.

Table 5.50 DC Characteristics (4) [2.7 V ≤ V_{CC} < 4.0 V]
(T_{opr} = −20 to 85°C (N version)/ −40 to 85°C (D version), unless otherwise specified.)

Symbol	Parameter		Condition							Standard			Unit
			Oscillation Circuit		On-Chip Oscillator		CPU Clock	Low-Power-Consumption Setting	Other	Min.	Typ. (3)	Max.	
			XIN (2)	XCIN	High-Speed	Low-Speed							
I _{CC}	Power supply current (1)	High-speed clock mode	20 MHz	Off	Off	125 kHz	No division	–	–	4.7	10	mA	
			10 MHz	Off	Off	125 kHz	No division	–	–	2.3	6	mA	
			20 MHz	Off	Off	Off	No division	FMR27 = 1 MSTCR0 = BEh MSTCR1 = 3Fh	Flash memory off Program operation on RAM Module standby setting enabled	–	2.9	–	mA
			20 MHz	Off	Off	125 kHz	Divide-by-8	–	–	–	1.8	–	mA
			10 MHz	Off	Off	125 kHz	Divide-by-8	–	–	–	1.0	–	mA
		High-speed on-chip oscillator mode	Off	Off	20 MHz	125 kHz	No division	–	–	–	5.0	11	mA
			Off	Off	20 MHz	125 kHz	Divide-by-8	–	–	–	2.1	–	mA
			Off	Off	10 MHz	125 kHz	No division	–	–	–	2.9	–	mA
			Off	Off	10 MHz	125 kHz	Divide-by-8	–	–	–	1.5	–	mA
			Off	Off	4 MHz	125 kHz	Divide-by-16	MSTCR0 = BEh MSTCR1 = 3Fh	–	–	0.9	–	mA
	Low-speed on-chip oscillator mode	Off	Off	Off	125 kHz	No division	FMR27 = 1 VCA20 = 0	–	–	106	300	μA	
		Off	Off	Off	125 kHz	Divide-by-8	FMR27 = 1 VCA20 = 0	–	–	54	200	μA	
	Low-speed clock mode	Off	32 kHz	Off	Off	No division	FMR27 = 1 VCA20 = 0	–	–	54	200	μA	
		Off	32 kHz	Off	Off	No division	FMSTP = 1 VCA20 = 0	Flash memory off Program operation on RAM	–	36	–	μA	
	Wait mode	Off	Off	Off	125 kHz	–	VCA27 = 0 VCA26 = 0 VCA25 = 0 VCA20 = 1	While a WAIT instruction is executed Peripheral clock operation	–	9.0	50	μA	
		Off	Off	Off	125 kHz	–	VCA27 = 0 VCA26 = 0 VCA25 = 0 VCA20 = 1 CM02 = 1 CM01 = 1	While a WAIT instruction is executed Peripheral clock off	–	2.5	31	μA	
		Off	32 kHz	Off	Off	–	VCA27 = 0 VCA26 = 0 VCA25 = 0 VCA20 = 1 CM02 = 1 CM01 = 0	While a WAIT instruction is executed Peripheral clock off Timer RH operation in real-time clock mode	LCD drive control circuit (4) When external division resistors are used	–	3.1	–	μA
		Off	32 kHz	Off	Off	–	VCA27 = 0 VCA26 = 0 VCA25 = 0 VCA20 = 1 CM02 = 1 CM01 = 1	While a WAIT instruction is executed Peripheral clock off Timer RH operation in real-time clock mode	–	1.7	–	μA	
		Off	Off	Off	Off	–	VCA27 = 0 VCA26 = 0 VCA25 = 0 CM10 = 1	Topr = 25°C Peripheral clock off	–	0.5	2.2	μA	
	Stop mode	Off	Off	Off	Off	–	VCA27 = 0 VCA26 = 0 VCA25 = 0 CM10 = 1	Topr = 85°C Peripheral clock off	–	1.2	–	μA	
		Off	Off	Off	Off	–	VCA27 = 0 VCA26 = 0 VCA25 = 0 CM10 = 1	Power-off 0 Topr = 25°C	–	0.01	0.1	μA	
	Power-off mode	Off	Off	Off	Off	–	VCA27 = 0 VCA26 = 0 VCA25 = 0 CM10 = 1	Power-off 0 Topr = 85°C	–	0.02	–	μA	
		Off	32 kHz	Off	Off	–	VCA27 = 0 VCA26 = 0 VCA25 = 0 CM10 = 1	Power-off 2 Topr = 25°C	–	1.3	4.5	μA	
		Off	32 kHz	Off	Off	–	VCA27 = 0 VCA26 = 0 VCA25 = 0 CM10 = 1	Power-off 2 Topr = 85°C	–	2.2	–	μA	
Off		Off	Off	Off	–	VCA27 = 0 VCA26 = 0 VCA25 = 0 CM10 = 1	Power-off 0 Topr = 85°C	–	0.01	0.1	μA		

Notes:

- V_{CC} = 2.7 V to 4.0 V, single chip mode, output pins are open, and other pins are V_{SS}.
- XIN is set to square wave input.
- V_{CC} = 3.0 V
- VLCD = V_{CC}, external division resistors are used for VL3 to VL1, 1/3 bias, 1/4 duty, f(FR) = 64 Hz, SEG0 to SEG39 are selected, and segment and common output pins are open. The standard value does not include the current that flows through external division resistors.

Table 5.51 DC Characteristics (5) [1.8 V ≤ V_{CC} < 2.7 V]
(T_{opr} = -20 to 85°C (N version)/ -40 to 85°C (D version), unless otherwise specified.)

Symbol	Parameter		Condition		Standard			Unit
					Min.	Typ.	Max.	
V _{OH}	Output "H" voltage		Port P7_0, P7_1, P8 (1)	I _{OH} = -2 mA	V _{CC} - 0.5	-	V _{CC}	V
			Other pins	I _{OH} = -1 mA	V _{CC} - 0.5	-	V _{CC}	V
V _{OL}	Output "L" voltage		Port P7_0, P7_1, P8 (1)	I _{OL} = 2 mA	-	-	0.5	V
			Other pins	I _{OL} = 1 mA	-	-	0.5	V
V _{T+} -V _{T-}	Hysteresis	INT0, INT1, INT2, INT3, INT4, INT5, INT6, INT7, KI0, KI1, KI2, KI3, KI4, KI5, KI6, KI7, TRCIOA, TRCIOB, TRCIOC, TRCIOD, TRJ0IO, TRJ1IO, TRJ2IO, TRCTRG, TRCCLK, ADTRG, RXD0, RXD2, CLK0, CLK2, SSI, SCL, SDA, SSO			0.05	0.4	-	V
		RESET, WKUP0			0.1	0.8	-	V
I _{IH}	Input "H" current		V _I = 1.8 V, V _{CC} = 1.8 V		-	-	4.0	μA
I _{IL}	Input "L" current		V _I = 0 V, V _{CC} = 1.8 V		-	-	-4.0	μA
R _{PULLUP}	Pull-up resistance		V _I = 0 V, V _{CC} = 1.8 V		85	220	500	kΩ
R _{iXIN}	Feedback resistance	XIN			-	2.0	-	MΩ
R _{iXCIN}	Feedback resistance	XCIN			-	14	-	MΩ
V _{RAM}	RAM hold voltage		During stop mode		1.8	-	-	V

Note:

1. This applies when the drive capacity of the output transistor is set to High by registers P7DRR and P8DRR. When the drive capacity is set to Low, the value of any other pin applies.

Table 5.52 DC Characteristics (6) [$1.8\text{ V} \leq V_{CC} < 2.7\text{ V}$]
($T_{opr} = -20\text{ to }85^\circ\text{C}$ (N version)/ $-40\text{ to }85^\circ\text{C}$ (D version), unless otherwise specified.)

Symbol	Parameter		Condition							Standard			Unit	
			Oscillation Circuit		On-Chip Oscillator		CPU Clock	Low-Power-Consumption Setting	Other	Min.	Typ. (3)	Max.		
			XIN (2)	XCIN	High-Speed	Low-Speed								
I _{CC}	Power supply current (1)	High-speed clock mode	8 MHz	Off	Off	125 kHz	No division	–		–	2.1	–	mA	
			8 MHz	Off	Off	125 kHz	Divide-by-8	–		–	0.9	–	mA	
		High-speed on-chip oscillator mode	Off	Off	5 MHz	125 kHz	No division	–		–	1.8	5	mA	
			Off	Off	5 MHz	125 kHz	Divide-by-8	–		–	1.1	–	mA	
			Off	Off	4 MHz	125 kHz	Divide-by-16	MSTCR0 = BEh MSTCR1 = 3Fh		–	0.9	–	mA	
		Low-speed on-chip oscillator mode	Off	Off	Off	125 kHz	No division	FMR27 = 1 VCA20 = 0		–	106	300	μA	
			Off	Off	Off	125 kHz	Divide-by-8	FMR27 = 1 VCA20 = 0		–	54	200	μA	
		Low-speed clock mode	Off	32 kHz	Off	Off	No division	FMR27 = 1 VCA20 = 0		–	54	200	μA	
			Off	32 kHz	Off	Off	No division	FMSTP = 1 VCA20 = 0	Flash memory off Program operation on RAM	–	36	–	μA	
		Wait mode	Off	Off	Off	125 kHz	–	VCA27 = 0 VCA26 = 0 VCA25 = 0 VCA20 = 1	While a WAIT instruction is executed Peripheral clock operation	–	9.0	50	μA	
			Off	Off	Off	125 kHz	–	VCA27 = 0 VCA26 = 0 VCA25 = 0 VCA20 = 1 CM02 = 1 CM01 = 1	While a WAIT instruction is executed Peripheral clock off	–	2.5	31	μA	
			Off	32 kHz	Off	Off	–	VCA27 = 0 VCA26 = 0 VCA25 = 0 VCA20 = 1 CM02 = 1 CM01 = 0	While a WAIT instruction is executed Peripheral clock off Timer RH operation in real-time clock mode	LCD drive control circuit (4) When external division resistors are used	–	2.4	–	μA
			Off	32 kHz	Off	Off	–	VCA27 = 0 VCA26 = 0 VCA25 = 0 VCA20 = 1 CM02 = 1 CM01 = 1	While a WAIT instruction is executed Peripheral clock off Timer RH operation in real-time clock mode	–	1.7	–	μA	
		Stop mode	Off	Off	Off	Off	–	VCA27 = 0 VCA26 = 0 VCA25 = 0 CM10 = 1	Topr = 25°C Peripheral clock off	–	0.5	2.2	μA	
			Off	Off	Off	Off	–	VCA27 = 0 VCA26 = 0 VCA25 = 0 VCA20 = 1	Topr = 85°C Peripheral clock off	–	1.2	–	μA	
		Power-off mode	Off	Off	Off	Off	–	–	Power-off 0 Topr = 25°C	–	0.01	0.1	μA	
Off	Off		Off	Off	–	–	Power-off 0 Topr = 85°C	–	0.02	–	μA			
Off	32 kHz		Off	Off	–	VCA27 = 0 VCA26 = 0 VCA25 = 0 CM10 = 1	Power-off 2 Topr = 25°C	–	1.2	4	μA			
Off	32 kHz		Off	Off	–	VCA27 = 0 VCA26 = 0 VCA25 = 0 CM10 = 1	Power-off 2 Topr = 85°C	–	2	–	μA			

Notes:

1. $V_{CC} = 1.8\text{ V}$ to 2.7 V , single chip mode, output pins are open, and other pins are Vss.
2. XIN is set to square wave input.
3. $V_{CC} = 2.2\text{ V}$
4. VLCD = V_{CC}, external division resistors are used for VL3 to VL1, 1/3 bias, 1/4 duty, f(FR) = 64 Hz, SEG0 to SEG39 are selected, and segment and common output pins are open. The standard value does not include the current that flows through external division resistors.

5.2.5 AC Characteristics

Table 5.53 Timing Requirements of Synchronous Serial Communication Unit (SSU)
($V_{CC} = 1.8$ to 5.5 V, $V_{SS} = 0$ V, and $T_{opr} = -20$ to 85°C (N version)/ -40 to 85°C (D version), unless otherwise specified.)

Symbol	Parameter		Conditions	Standard			Unit
				Min.	Typ.	Max.	
tsucyc	SSCK clock cycle time			4	–	–	tcyc (1)
tHI	SSCK clock “H” width			0.4	–	0.6	tsucyc
tLO	SSCK clock “L” width			0.4	–	0.6	tsucyc
trISE	SSCK clock rising time	Master		–	–	1	tcyc (1)
		Slave		–	–	1	μs
tFALL	SSCK clock falling time	Master		–	–	1	tcyc (1)
		Slave		–	–	1	μs
tsu	SSO, SSI data input setup time			100	–	–	ns
tH	SSO, SSI data input hold time			1	–	–	tcyc (1)
tLEAD	$\overline{\text{SCS}}$ setup time	Slave		$1\text{tcyc} + 50$	–	–	ns
tLAG	$\overline{\text{SCS}}$ hold time	Slave		$1\text{tcyc} + 50$	–	–	ns
tOD	SSO, SSI data output delay time			–	–	$1\text{tcyc} + 20$	ns
tSA	SSI slave access time		$2.7\text{ V} \leq V_{CC} \leq 5.5\text{ V}$	–	–	$1.5\text{tcyc} + 100$	ns
			$1.8\text{ V} \leq V_{CC} < 2.7\text{ V}$	–	–	$1.5\text{tcyc} + 200$	ns
tOR	SSI slave out open time		$2.7\text{ V} \leq V_{CC} \leq 5.5\text{ V}$	–	–	$1.5\text{tcyc} + 100$	ns
			$1.8\text{ V} \leq V_{CC} < 2.7\text{ V}$	–	–	$1.5\text{tcyc} + 200$	ns

Note:

1. $1\text{tcyc} = 1/f_1(\text{s})$

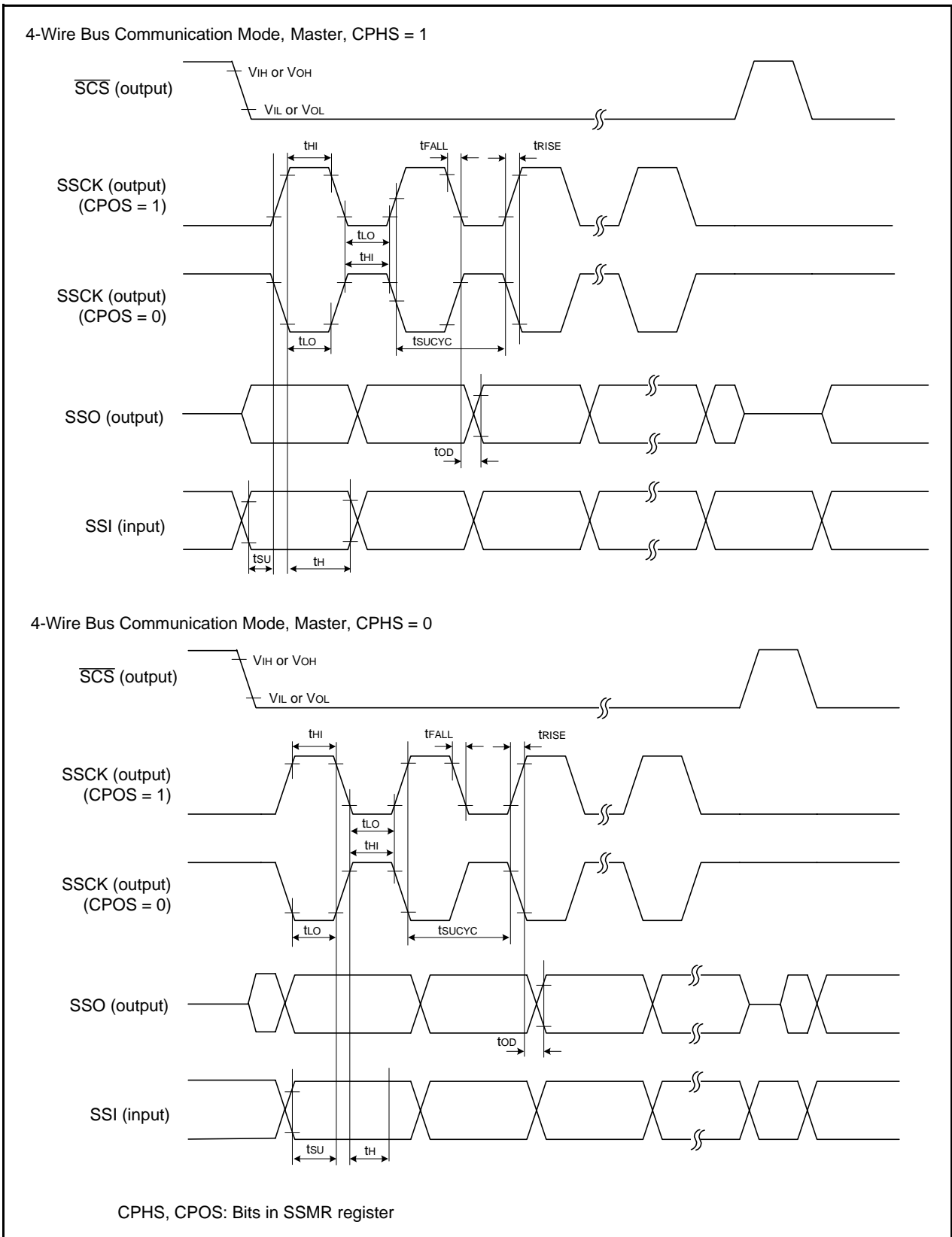

Figure 5.15 I/O Timing of Synchronous Serial Communication Unit (SSU) (Master)

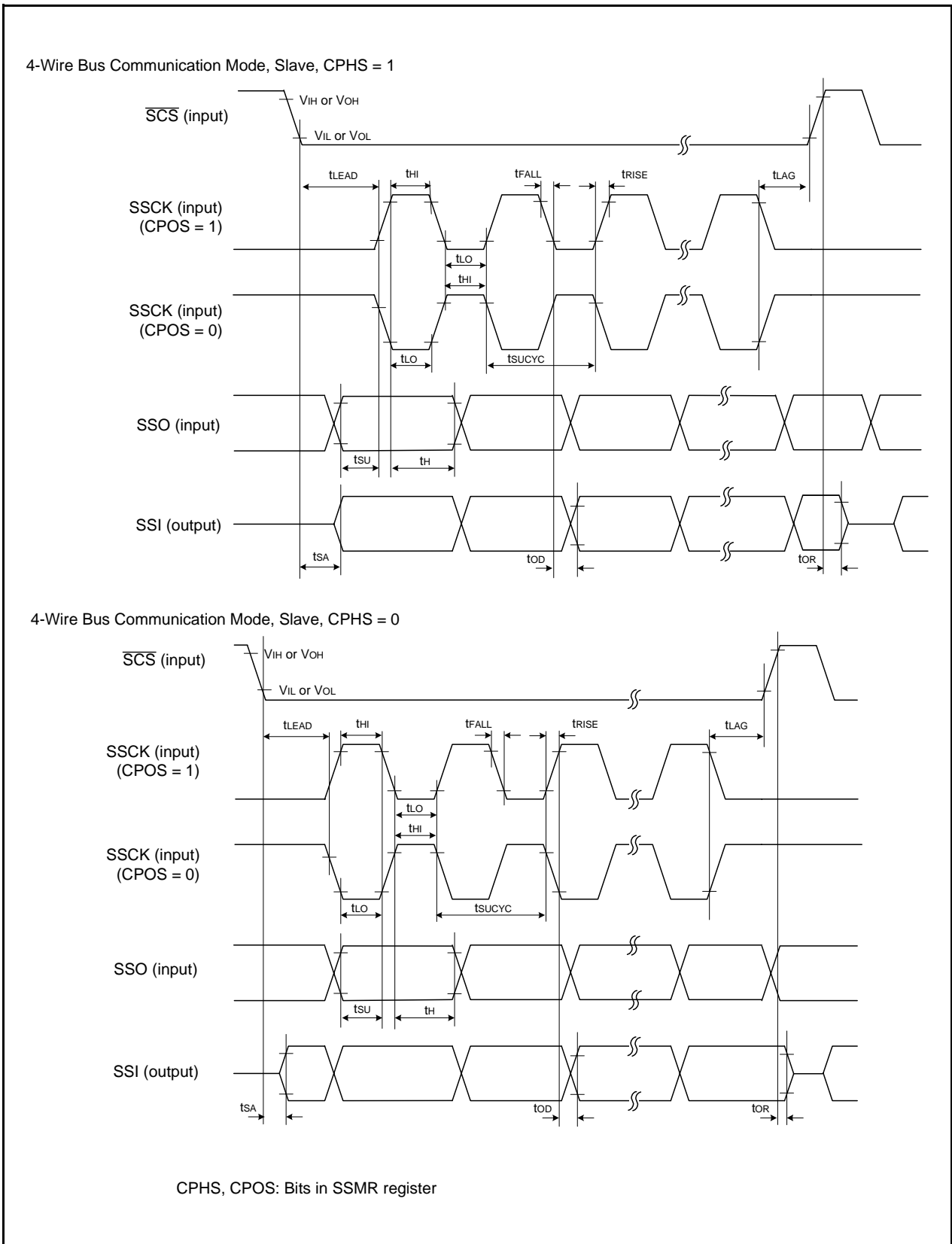

Figure 5.16 I/O Timing of Synchronous Serial Communication Unit (SSU) (Slave)

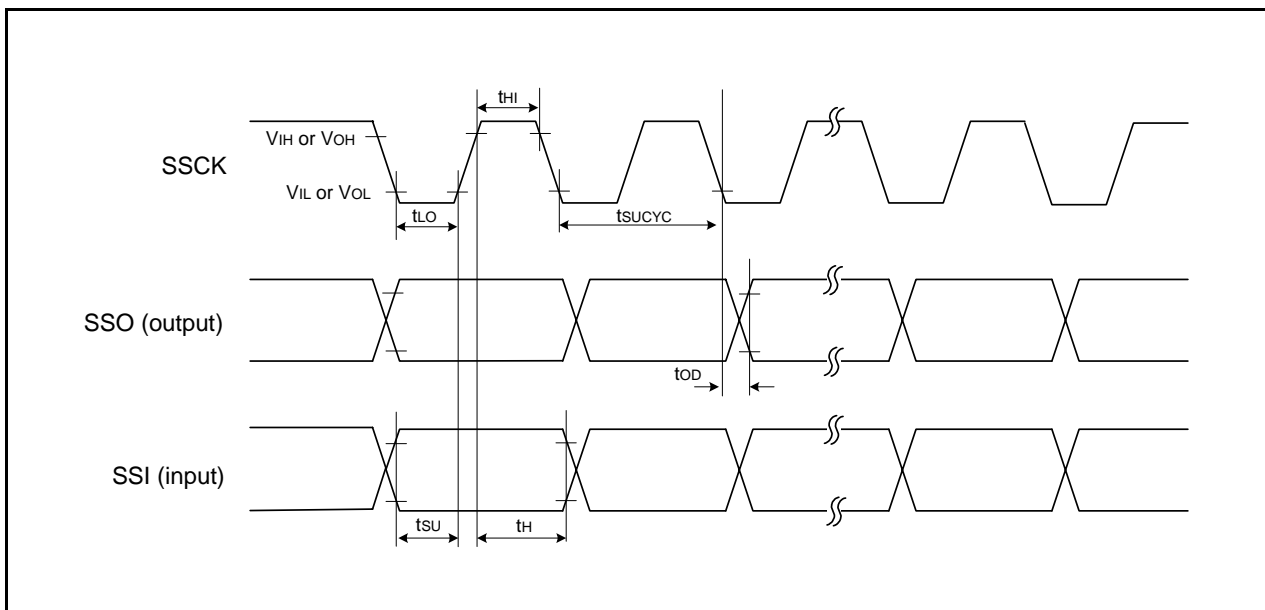

Figure 5.17 I/O Timing of Synchronous Serial Communication Unit (SSU) (Clock Synchronous Communication Mode)

Table 5.54 Timing Requirements of I²C bus Interface (1)
(V_{CC} = 1.8 to 5.5 V, V_{SS} = 0 V, and T_{opr} = -20 to 85°C (N version)/ -40 to 85°C (D version), unless otherwise specified.)

Symbol	Parameter	Condition	Standard			Unit
			Min.	Typ.	Max.	
t _{SCL}	SCL input cycle time		12tcyc + 600 (1)	–	–	ns
t _{SCLH}	SCL input “H” width		3tcyc + 300 (1)	–	–	ns
t _{SCLL}	SCL input “L” width		5tcyc + 500 (1)	–	–	ns
t _{sf}	SCL, SDA input fall time		–	–	300	ns
t _{SP}	SCL, SDA input spike pulse rejection time		–	–	1tcyc (1)	ns
t _{BUF}	SDA input bus-free time		5tcyc (1)	–	–	ns
t _{STAH}	Start condition input hold time		3tcyc (1)	–	–	ns
t _{STAS}	Retransmit start condition input setup time		3tcyc (1)	–	–	ns
t _{STOP}	Stop condition input setup time		3tcyc (1)	–	–	ns
t _{SDAS}	Data input setup time		1tcyc + 40 (1)	–	–	ns
t _{SDAH}	Data input hold time		10	–	–	ns

Note:

- 1tcyc = 1/f1(s)

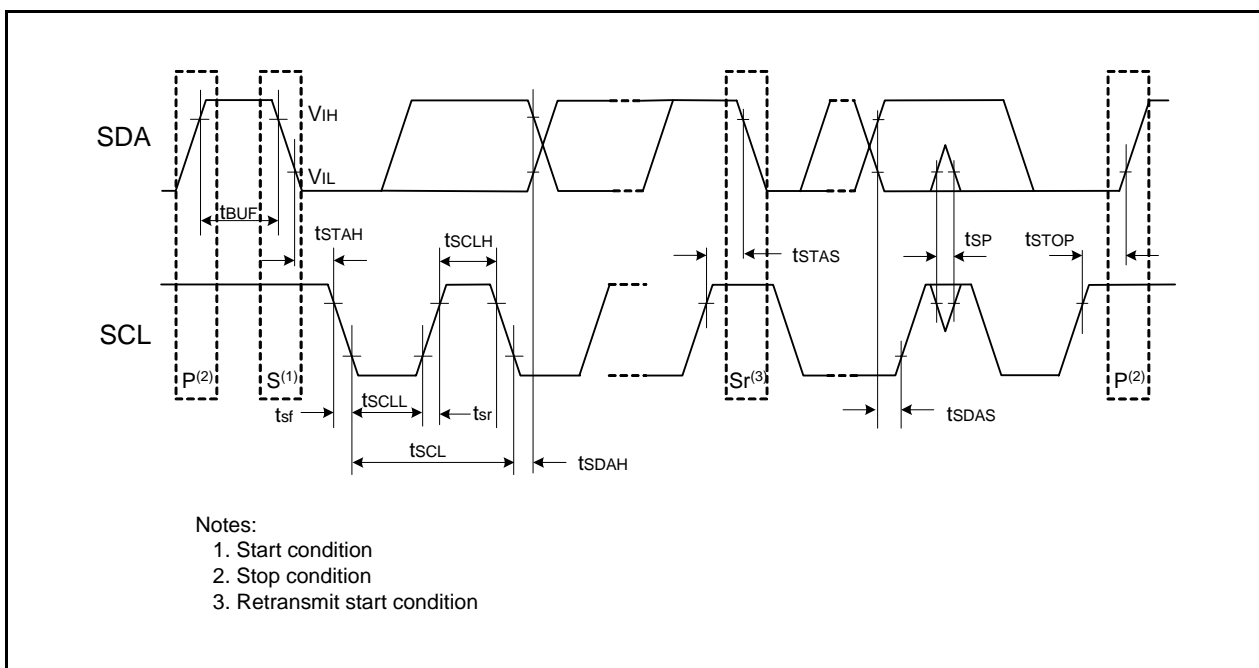

Figure 5.18 I/O Timing of I²C bus Interface

Table 5.55 Timing Requirements of External Clock Input (XIN, XCIN)
($V_{SS} = 0\text{ V}$ and $T_{opr} = -20\text{ to }85^\circ\text{C}$ (N version)/ $-40\text{ to }85^\circ\text{C}$ (D version), unless otherwise specified.)

Symbol	Parameter	Standard						Unit
		$V_{CC} = 2.2\text{V}, T_{opr} = 25^\circ\text{C}$		$V_{CC} = 3\text{V}, T_{opr} = 25^\circ\text{C}$		$V_{CC} = 5\text{V}, T_{opr} = 25^\circ\text{C}$		
		Min.	Max.	Min.	Max.	Min.	Max.	
$t_{c(XIN)}$	XIN input cycle time	200	–	50	–	50	–	ns
$t_{WH(XIN)}$	XIN input “H” width	90	–	24	–	24	–	ns
$t_{WL(XIN)}$	XIN input “L” width	90	–	24	–	24	–	ns
$t_{c(XCIN)}$	XCIN input cycle time	20	–	20	–	20	–	μs
$t_{WH(XCIN)}$	XCIN input “H” width	10	–	10	–	10	–	μs
$t_{WL(XCIN)}$	XCIN input “L” width	10	–	10	–	10	–	μs

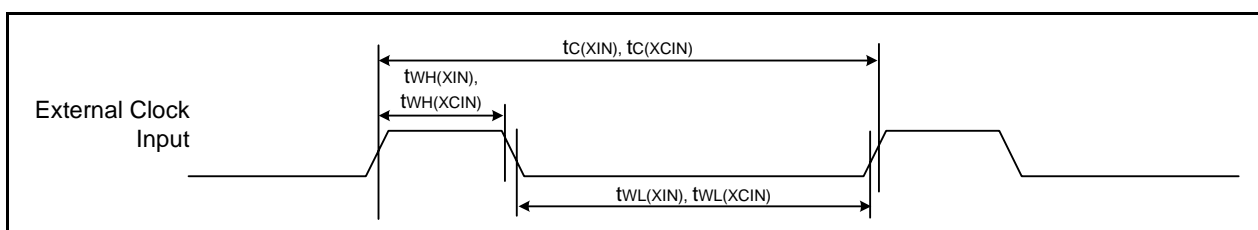

Figure 5.19 External Clock Input Timing

Table 5.56 Timing Requirements of TRJiIO (i = 0 to 2)
($V_{SS} = 0\text{ V}$ and $T_{opr} = -20\text{ to }85^\circ\text{C}$ (N version)/ $-40\text{ to }85^\circ\text{C}$ (D version), unless otherwise specified.)

Symbol	Parameter	Standard						Unit
		$V_{CC} = 2.2\text{V}, T_{opr} = 25^\circ\text{C}$		$V_{CC} = 3\text{V}, T_{opr} = 25^\circ\text{C}$		$V_{CC} = 5\text{V}, T_{opr} = 25^\circ\text{C}$		
		Min.	Max.	Min.	Max.	Min.	Max.	
$t_{c(TRJIO)}$	TRJiIO input cycle time	500	–	300	–	100	–	ns
$t_{WH(TRJIO)}$	TRJiIO input “H” width	200	–	120	–	40	–	ns
$t_{WL(TRJIO)}$	TRJiIO input “L” width	200	–	120	–	40	–	ns

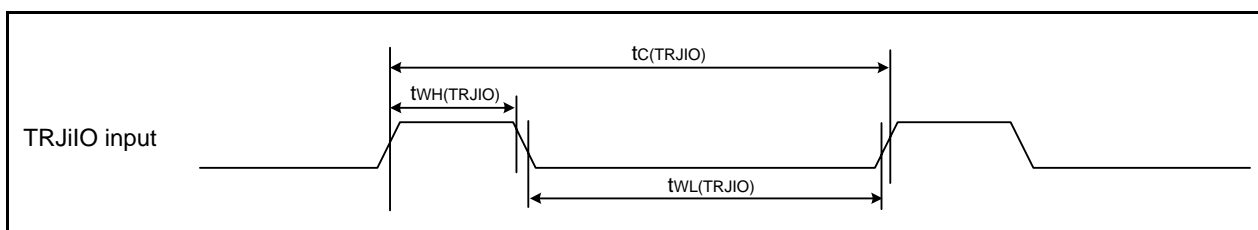

Figure 5.20 Input Timing of TRJiIO

Table 5.57 Timing Requirements of Serial Interface
($V_{SS} = 0\text{ V}$ and $T_{opr} = -20\text{ to }85^\circ\text{C}$ (N version)/ $-40\text{ to }85^\circ\text{C}$ (D version), unless otherwise specified.)

Symbol	Parameter	Standard						Unit
		$V_{CC} = 2.2\text{V}, T_{opr} = 25^\circ\text{C}$		$V_{CC} = 3\text{V}, T_{opr} = 25^\circ\text{C}$		$V_{CC} = 5\text{V}, T_{opr} = 25^\circ\text{C}$		
		Min.	Max.	Min.	Max.	Min.	Max.	
$t_{c(CK)}$	CLKi input cycle time	800	–	300	–	200	–	ns
$t_{w(CKH)}$	CLKi input “H” width	400	–	150	–	100	–	ns
$t_{w(CKL)}$	CLKi input “L” width	400	–	150	–	100	–	ns
$t_d(C-Q)$	TXDi output delay time	–	200	–	80	–	50	ns
$t_h(C-Q)$	TXDi hold time	0	–	0	–	0	–	ns
$t_{su}(D-C)$	RXDi input setup time	150	–	70	–	50	–	ns
$t_h(C-D)$	RXDi input hold time	90	–	90	–	90	–	ns

$i = 0, 2$

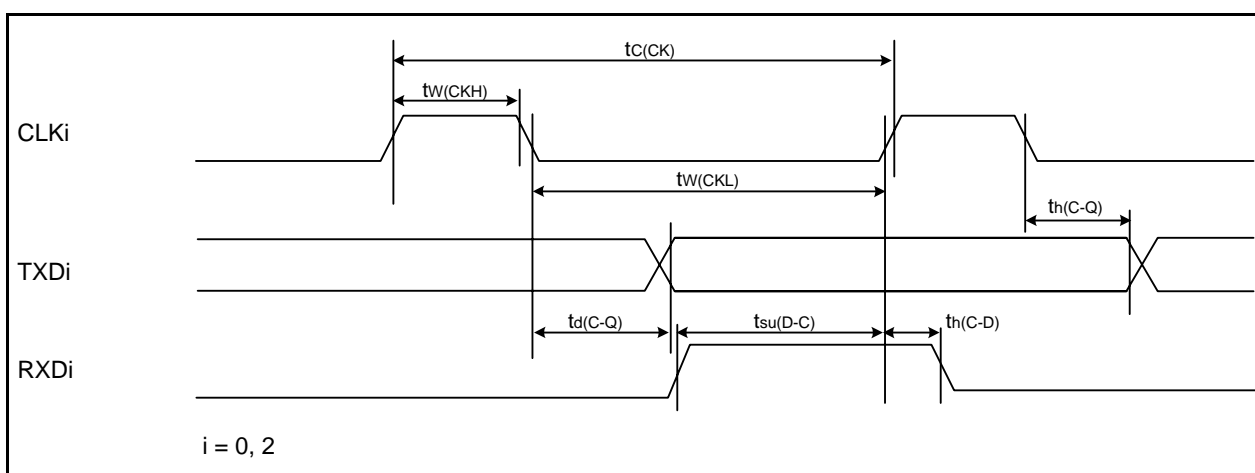

Figure 5.21 Input and Output Timing of Serial Interface

Table 5.58 Timing Requirements of External Interrupt \overline{INTi} ($i = 0$ to 7) and Key Input Interrupt \overline{Kli} ($i = 0$ to 7)
($V_{SS} = 0\text{ V}$ and $T_{opr} = -20\text{ to }85^\circ\text{C}$ (N version)/ $-40\text{ to }85^\circ\text{C}$ (D version), unless otherwise specified.)

Symbol	Parameter	Standard						Unit
		$V_{CC} = 2.2\text{V}, T_{opr} = 25^\circ\text{C}$		$V_{CC} = 3\text{V}, T_{opr} = 25^\circ\text{C}$		$V_{CC} = 5\text{V}, T_{opr} = 25^\circ\text{C}$		
		Min.	Max.	Min.	Max.	Min.	Max.	
$t_{w(INH)}$	\overline{INTi} input “H” width, \overline{Kli} input “H” width	1000 (1)	–	380 (1)	–	250 (1)	–	ns
$t_{w(INL)}$	\overline{INTi} input “L” width, \overline{Kli} input “L” width	1000 (2)	–	380 (2)	–	250 (2)	–	ns

Notes:

- When selecting the digital filter by the \overline{INTi} input filter select bit, use an \overline{INTi} input HIGH width of either (1/digital filter clock frequency \times 3) or the minimum value of standard, whichever is greater.
- When selecting the digital filter by the \overline{INTi} input filter select bit, use an \overline{INTi} input LOW width of either (1/digital filter clock frequency \times 3) or the minimum value of standard, whichever is greater.

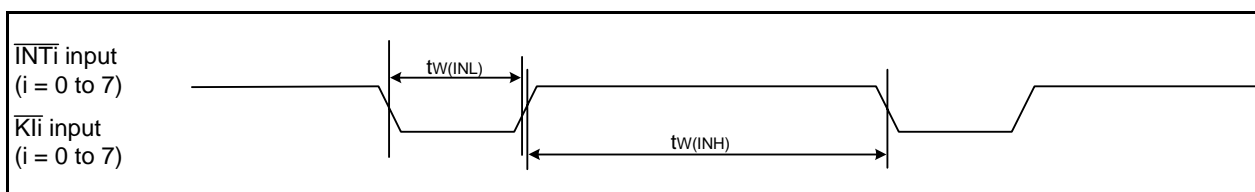
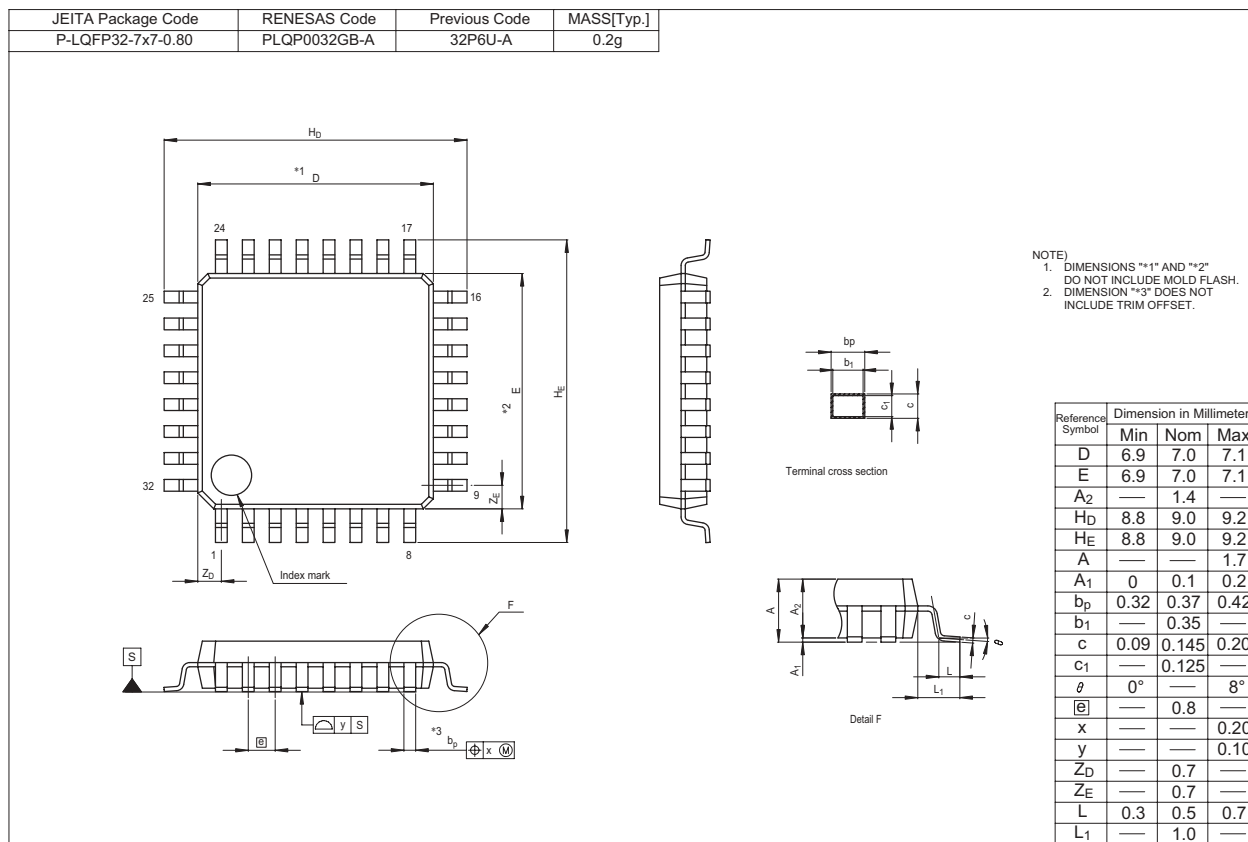
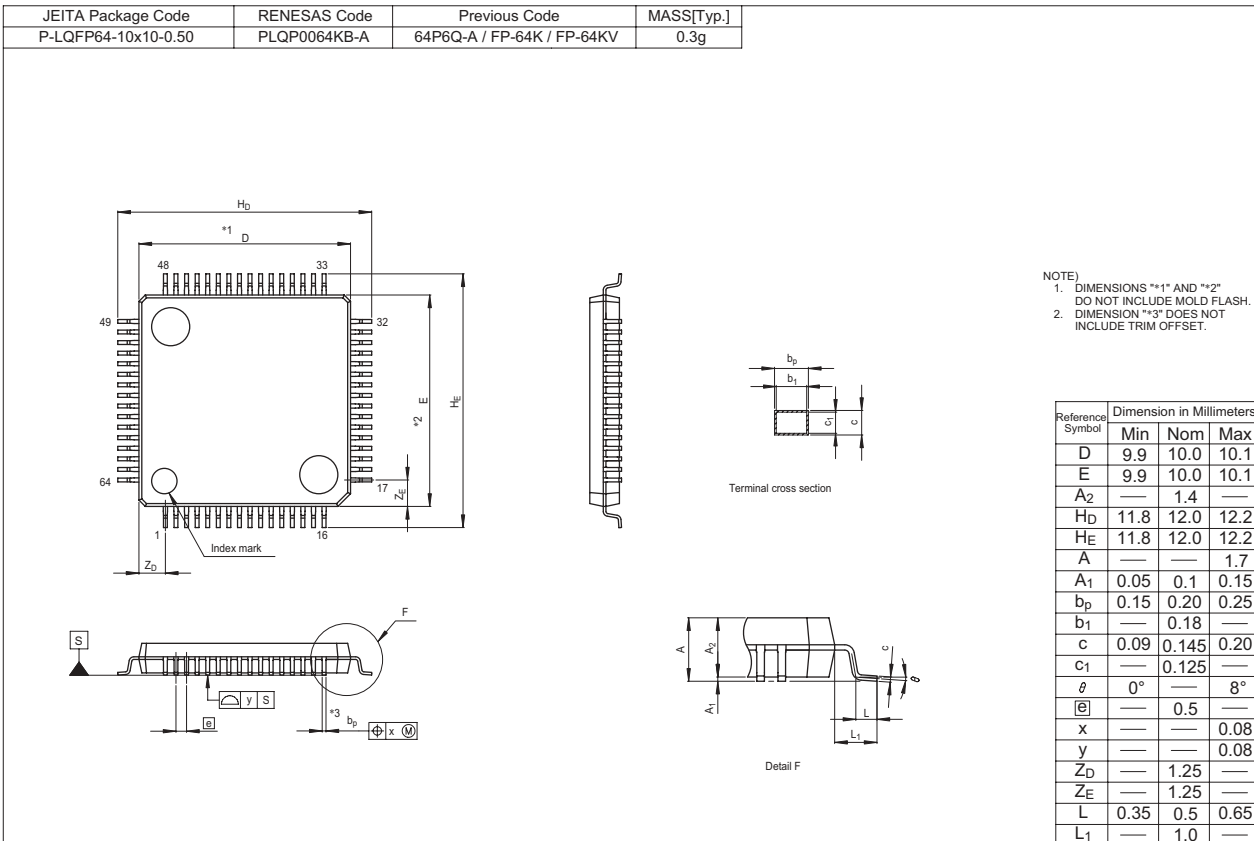
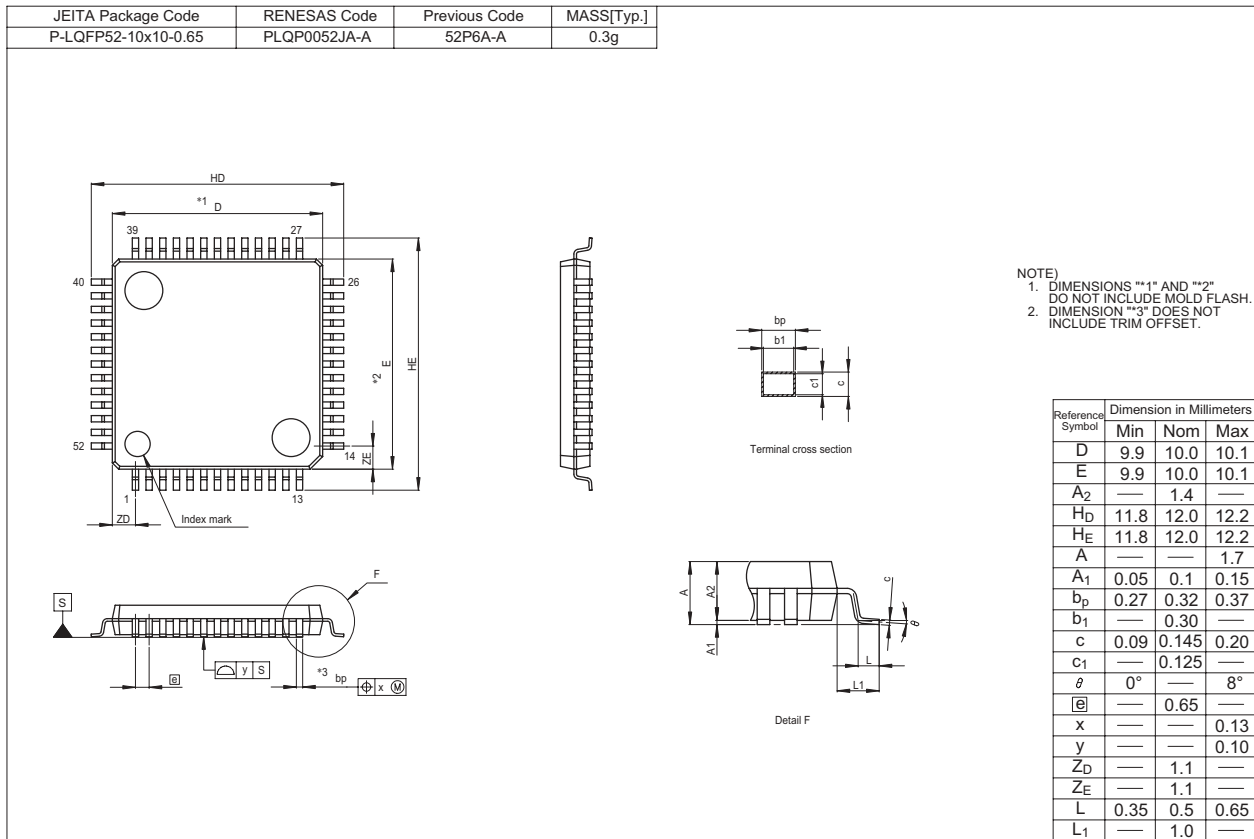

Figure 5.22 Input Timing of External Interrupt \overline{INTi} and Key Input Interrupt \overline{Kli}

Package Dimensions

Diagrams showing the latest package dimensions and mounting information are available in the “Packages” section of the Renesas Electronics web site.





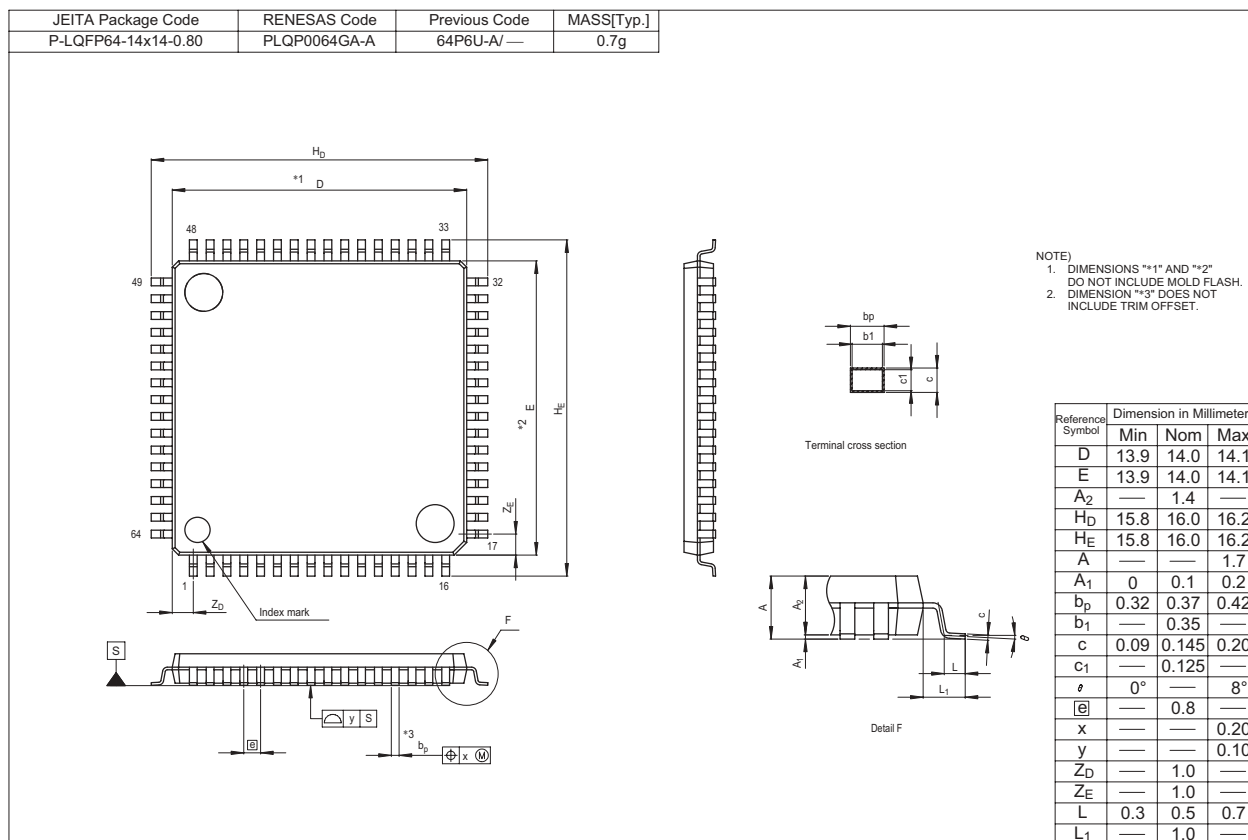

REVISION HISTORY

R8C/LA3A Group, R8C/LA5A Group, R8C/LA6A Group, R8C/LA8A Group Datasheet

Rev.	Date	Description	
		Page	Summary
0.01	Jan 18, 2010	—	First Edition issued
0.02	Jul 16, 2010	2	Table 1.1 revised
		3	Table 1.2 revised
		4	Tables 1.4 and 1.5 revised
		5	Table 1.6 revised
		6	Table 1.7 revised
		7	Table 1.8 revised
		8	Table 1.9 and Figure 1.1 revised
		9	Table 1.10 and Figure 1.2 revised
		10	Table 1.11 and Figure 1.3 revised
		11	Table 1.12 revised
		12	Figure 1.5 revised
		13	Figure 1.6 revised
		14	Figure 1.7 revised
		16	Figure 1.9 revised
		17	Figure 1.10 revised
		18	Table 1.13 revised
		19	Table 1.14 revised
		20	Figure 1.11 revised
		21	Figure 1.12 revised
		25	Table 1.18 revised
		26	Table 1.19 revised
30	Figure 3.1 revised		
31	Table 4.1, Note 3 revised		
35	Table 4.5 revised		
		41 to 44	Package Dimensions revised
1.00	Dec 21, 2010	All	"Preliminary" and "Under development" deleted
		2	Table 1.1 revised
		3	Tables 1.2 and 1.3 Note 2 revised
		4	Tables 1.4 and 1.5 Note 1 revised
		6	Table 1.7 revised
		7	Table 1.8 revised
		10	Table 1.11 and Figure 1.3 revised
		12	Figure 1.5 revised
		13	Figure 1.6 revised
		14	Figure 1.7 revised
		15	Figure 1.8 revised
		16	Figure 1.9 revised
		18	Table 1.13 revised
		19	Table 1.14 revised
		20	Figure 1.11 revised
		22	Table 1.15 revised
23	Table 1.16 revised		
24	Table 1.17 revised		
		25, 26	Tables 1.18 and 1.19 Pin Functions for R8C/LA5A Group added

REVISION HISTORY

R8C/LA3A Group, R8C/LA5A Group, R8C/LA6A Group, R8C/LA8A Group Datasheet

Rev.	Date	Description	
		Page	Summary
1.00	Dec 21, 2010	32	"The internal ROM (program ROM) is allocated lower addresses, beginning with address 0FFFFh." deleted
		33 to 41	Figure 3.1 revised
		52 to 98	Tables 4.1 to 4.9 SFR information for R8C/LA5A Group added
		92	"5. Electrical Characteristics" added
1.01	Oct 28, 2011	92	Package Dimensions "PVQN0064LB-A" deleted
		1	1.1 "... data flash (1 KB x 2 blocks)." → "... data flash."
		10	Table 1.11, Figure 1.3 revised
		11	Table 1.12, Figure 1.4 revised
		32	3 revised, Figure 3.1 revised
		60	Table 5.12 revised
		80	Table 5.36 revised
		81	Table 5.37 revised
83	Table 5.41 revised		

All trademarks and registered trademarks are the property of their respective owners.

General Precautions in the Handling of MPU/MCU Products

The following usage notes are applicable to all MPU/MCU products from Renesas. For detailed usage notes on the products covered by this manual, refer to the relevant sections of the manual. If the descriptions under General Precautions in the Handling of MPU/MCU Products and in the body of the manual differ from each other, the description in the body of the manual takes precedence.

1. Handling of Unused Pins

Handle unused pins in accord with the directions given under Handling of Unused Pins in the manual.

- The input pins of CMOS products are generally in the high-impedance state. In operation with an unused pin in the open-circuit state, extra electromagnetic noise is induced in the vicinity of LSI, an associated shoot-through current flows internally, and malfunctions occur due to the false recognition of the pin state as an input signal become possible. Unused pins should be handled as described under Handling of Unused Pins in the manual.

2. Processing at Power-on

The state of the product is undefined at the moment when power is supplied.

- The states of internal circuits in the LSI are indeterminate and the states of register settings and pins are undefined at the moment when power is supplied.

In a finished product where the reset signal is applied to the external reset pin, the states of pins are not guaranteed from the moment when power is supplied until the reset process is completed.

In a similar way, the states of pins in a product that is reset by an on-chip power-on reset function are not guaranteed from the moment when power is supplied until the power reaches the level at which resetting has been specified.

3. Prohibition of Access to Reserved Addresses

Access to reserved addresses is prohibited.

- The reserved addresses are provided for the possible future expansion of functions. Do not access these addresses; the correct operation of LSI is not guaranteed if they are accessed.

4. Clock Signals

After applying a reset, only release the reset line after the operating clock signal has become stable. When switching the clock signal during program execution, wait until the target clock signal has stabilized.

- When the clock signal is generated with an external resonator (or from an external oscillator) during a reset, ensure that the reset line is only released after full stabilization of the clock signal. Moreover, when switching to a clock signal produced with an external resonator (or by an external oscillator) while program execution is in progress, wait until the target clock signal is stable.

5. Differences between Products

Before changing from one product to another, i.e. to one with a different part number, confirm that the change will not lead to problems.

- The characteristics of MPU/MCU in the same group but having different part numbers may differ because of the differences in internal memory capacity and layout pattern. When changing to products of different part numbers, implement a system-evaluation test for each of the products.

Notice

- All information included in this document is current as of the date this document is issued. Such information, however, is subject to change without any prior notice. Before purchasing or using any Renesas Electronics products listed herein, please confirm the latest product information with a Renesas Electronics sales office. Also, please pay regular and careful attention to additional and different information to be disclosed by Renesas Electronics such as that disclosed through our website.
- Renesas Electronics does not assume any liability for infringement of patents, copyrights, or other intellectual property rights of third parties by or arising from the use of Renesas Electronics products or technical information described in this document. No license, express, implied or otherwise, is granted hereby under any patents, copyrights or other intellectual property rights of Renesas Electronics or others.
- You should not alter, modify, copy, or otherwise misappropriate any Renesas Electronics product, whether in whole or in part.
- Descriptions of circuits, software and other related information in this document are provided only to illustrate the operation of semiconductor products and application examples. You are fully responsible for the incorporation of these circuits, software, and information in the design of your equipment. Renesas Electronics assumes no responsibility for any losses incurred by you or third parties arising from the use of these circuits, software, or information.
- When exporting the products or technology described in this document, you should comply with the applicable export control laws and regulations and follow the procedures required by such laws and regulations. You should not use Renesas Electronics products or the technology described in this document for any purpose relating to military applications or use by the military, including but not limited to the development of weapons of mass destruction. Renesas Electronics products and technology may not be used for or incorporated into any products or systems whose manufacture, use, or sale is prohibited under any applicable domestic or foreign laws or regulations.
- Renesas Electronics has used reasonable care in preparing the information included in this document, but Renesas Electronics does not warrant that such information is error free. Renesas Electronics assumes no liability whatsoever for any damages incurred by you resulting from errors in or omissions from the information included herein.
- Renesas Electronics products are classified according to the following three quality grades: "Standard", "High Quality", and "Specific". The recommended applications for each Renesas Electronics product depends on the product's quality grade, as indicated below. You must check the quality grade of each Renesas Electronics product before using it in a particular application. You may not use any Renesas Electronics product for any application categorized as "Specific" without the prior written consent of Renesas Electronics. Further, you may not use any Renesas Electronics product for any application for which it is not intended without the prior written consent of Renesas Electronics. Renesas Electronics shall not be in any way liable for any damages or losses incurred by you or third parties arising from the use of any Renesas Electronics product for an application categorized as "Specific" or for which the product is not intended where you have failed to obtain the prior written consent of Renesas Electronics. The quality grade of each Renesas Electronics product is "Standard" unless otherwise expressly specified in a Renesas Electronics data sheets or data books, etc.
"Standard": Computers; office equipment; communications equipment; test and measurement equipment; audio and visual equipment; home electronic appliances; machine tools; personal electronic equipment; and industrial robots.
"High Quality": Transportation equipment (automobiles, trains, ships, etc.); traffic control systems; anti-disaster systems; anti-crime systems; safety equipment; and medical equipment not specifically designed for life support.
"Specific": Aircraft; aerospace equipment; submersible repeaters; nuclear reactor control systems; medical equipment or systems for life support (e.g. artificial life support devices or systems), surgical implantations, or healthcare intervention (e.g. excision, etc.), and any other applications or purposes that pose a direct threat to human life.
- You should use the Renesas Electronics products described in this document within the range specified by Renesas Electronics, especially with respect to the maximum rating, operating supply voltage range, movement power voltage range, heat radiation characteristics, installation and other product characteristics. Renesas Electronics shall have no liability for malfunctions or damages arising out of the use of Renesas Electronics products beyond such specified ranges.
- Although Renesas Electronics endeavors to improve the quality and reliability of its products, semiconductor products have specific characteristics such as the occurrence of failure at a certain rate and malfunctions under certain use conditions. Further, Renesas Electronics products are not subject to radiation resistance design. Please be sure to implement safety measures to guard them against the possibility of physical injury, and injury or damage caused by fire in the event of the failure of a Renesas Electronics product, such as safety design for hardware and software including but not limited to redundancy, fire control and malfunction prevention, appropriate treatment for aging degradation or any other appropriate measures. Because the evaluation of microcomputer software alone is very difficult, please evaluate the safety of the final products or system manufactured by you.
- Please contact a Renesas Electronics sales office for details as to environmental matters such as the environmental compatibility of each Renesas Electronics product. Please use Renesas Electronics products in compliance with all applicable laws and regulations that regulate the inclusion or use of controlled substances, including without limitation, the EU RoHS Directive. Renesas Electronics assumes no liability for damages or losses occurring as a result of your noncompliance with applicable laws and regulations.
- This document may not be reproduced or duplicated, in any form, in whole or in part, without prior written consent of Renesas Electronics.
- Please contact a Renesas Electronics sales office if you have any questions regarding the information contained in this document or Renesas Electronics products, or if you have any other inquiries.
(Note 1) "Renesas Electronics" as used in this document means Renesas Electronics Corporation and also includes its majority-owned subsidiaries.
(Note 2) "Renesas Electronics product(s)" means any product developed or manufactured by or for Renesas Electronics.



SALES OFFICES

Renesas Electronics Corporation

<http://www.renesas.com>

Refer to "<http://www.renesas.com/>" for the latest and detailed information.

Renesas Electronics America Inc.
2880 Scott Boulevard Santa Clara, CA 95050-2554, U.S.A.
Tel: +1-408-586-6000, Fax: +1-408-586-6130

Renesas Electronics Canada Limited
1101 Nicholson Road, Newmarket, Ontario L3Y 9C3, Canada
Tel: +1-905-898-5441, Fax: +1-905-898-3220

Renesas Electronics Europe Limited
Dukes Meadow, Millboard Road, Bourne End, Buckinghamshire, SL8 5FH, U.K.
Tel: +44-1628-585-100, Fax: +44-1628-585-900

Renesas Electronics Europe GmbH
Arcadiastrasse 10, 40472 Düsseldorf, Germany
Tel: +49-211-65030, Fax: +49-211-6503-1327

Renesas Electronics (China) Co., Ltd.
7th Floor, Quantum Plaza, No.27 ZhiChunLu Haidian District, Beijing 100083, P.R.China
Tel: +86-10-8235-1155, Fax: +86-10-8235-7679

Renesas Electronics (Shanghai) Co., Ltd.
Unit 204, 205, AZIA Center, No.1233 Lujiazui Ring Rd., Pudong District, Shanghai 200120, China
Tel: +86-21-5877-1818, Fax: +86-21-6887-7858 / -7898

Renesas Electronics Hong Kong Limited
Unit 1601-1613, 16/F., Tower 2, Grand Century Place, 193 Prince Edward Road West, Mongkok, Kowloon, Hong Kong
Tel: +852-2886-9318, Fax: +852 2886-9022/9044

Renesas Electronics Taiwan Co., Ltd.
13F, No. 363, Fu Shing North Road, Taipei, Taiwan
Tel: +886-2-8175-9600, Fax: +886 2-8175-9670

Renesas Electronics Singapore Pte. Ltd.
1 HarbourFront Avenue, #06-10, Keppel Bay Tower, Singapore 098632
Tel: +65-6213-0200, Fax: +65-6276-8001

Renesas Electronics Malaysia Sdn.Bhd.
Unit 906, Block B, Menara Amcorp, Amcorp Trade Centre, No. 18, Jin Persiaran Barat, 46050 Petaling Jaya, Selangor Darul Ehsan, Malaysia
Tel: +60-3-7955-9390, Fax: +60-3-7955-9510

Renesas Electronics Korea Co., Ltd.
11F., Samik Lavied' or Bldg., 720-2 Yeoksam-Dong, Kangnam-Ku, Seoul 135-080, Korea
Tel: +82-2-558-3737, Fax: +82-2-558-5141

Mouser Electronics

Authorized Distributor

Click to View Pricing, Inventory, Delivery & Lifecycle Information:

[Renesas Electronics:](#)

[R5F2LA8CANFA#V0](#) [R5F2LA34ADFP#30](#) [R5F2LA86ANFP#30](#) [R5F2LA38ANFP#30](#) [R5F2LA8AANFP#30](#)
[R5F2LA87ANFP#30](#) [R5F2LA58ANFP#30](#) [R5F2LA88ANFP#30](#) [R5F2LA8AADFP#30](#) [R5F2LA67ANFA#30](#)
[R5F2LA8AANFA#V0](#) [R5F2LA88ANFA#V0](#) [R5F2LA88ADFP#30](#) [R5F2LA32ADFP#30](#) [R5F2LA64ANFP#31](#)
[R5F2LA8CANFP#30](#) [R5F2LA54ANFP#30](#) [R5F2LA8CANWA#N0](#)