

User Manual

GreenPAK Advanced Development Platform

UM-GP-002

Abstract

This user manual provides basic guidelines for the developers to get familiar with the GreenPAK Advanced Development Platform. It gives an overview of the hardware, as well as the functional description of this platform, and shows the example projects using SLG46721.

Contents

Abstract	1
Contents	2
Figures	3
Tables	3
1 Terms and Definitions	4
2 Introduction	5
2.1 GreenPAK Designer	5
2.2 Support	5
3 Getting Started	6
3.1 Introduction	6
3.2 Install Hardware	6
3.3 Install Software	6
3.4 Uninstall Software	6
4 Hardware	7
4.1 Overview	7
4.2 Functional Description	7
4.2.1 Power Supply	7
4.2.2 USB Communication	8
4.2.3 GND Connections	8
4.2.4 Pin Test Points	8
4.2.5 LEDs	8
4.2.6 Socket Connector	8
4.2.7 Expansion Connector	8
4.2.8 Generators	12
4.2.9 Pins Connectivity	13
5 Example Projects using SLG46721	15
5.1 Project: Counter with Clock Enable	15
5.2 Project: LED String with Direction	25
6 Conclusion	31
Appendix A Electrical Specification	32
Appendix B Schematic Diagram	34
Appendix C BOM	38
Revision History	40

Figures

Figure 1: GreenPAK Advanced Development Board, Top View	7
Figure 2: USB Interface	8
Figure 3: GreenPAK Expansion Connector Schematic.....	9
Figure 4: Expansion Connector Control in GreenPAK Designer.....	9
Figure 5: Socket and Expansion Connector Schematic.....	10
Figure 6: Internal Power Source.....	11
Figure 7: Internal Power Source for GreenPAK Chip and External Development Platform	11
Figure 8: Expansion Connector. Pin with Protection Resistor.....	12
Figure 9: Choosing Generators	12
Figure 10: Managing Buttons	13
Figure 11: Global Linkage Settings	13
Figure 12: Pin Signal Sources/Loading Schematics	14
Figure 13: GreenPAK Designer.....	15
Figure 14: GreenPAK Components List	16
Figure 15: Pin 20 Mode	17
Figure 16: Look Up Table Properties Configured as AND Gate	18
Figure 17: Look Up Table Properties Configured as NOR Gate	19
Figure 18: Counter Properties	20
Figure 19: GreenPAK Designer.....	20
Figure 20: GreenPAK Designer, Emulation Tool	21
Figure 21: Signal Generator Connected to V _{DD} Pin	21
Figure 22: Signal Generator Settings	22
Figure 23: Logic Generator Properties	23
Figure 24: Waveform, Triggered on Button Pressed.....	23
Figure 25: Waveform, no Triggered on Button Released.....	24
Figure 26: Waveform of the Pulse Width of the Logic Generator and Count End Signal	24
Figure 27: Used Blocks for Current Project.....	25
Figure 28: Sine Waveform Generated with Signal Generator	25
Figure 29: Emulation Window, with Buffered LED and Signal Generator	26
Figure 30: Pin Properties.....	27
Figure 31: Pin Properties.....	28
Figure 32: Look Up Tables Properties Configured as XOR Gate	28
Figure 33: ACMP Properties.....	29
Figure 34: GreenPAK Designer.....	29
Figure 35: LED Output with Direction (Pin 2) Low	30
Figure 36: LED Output with Direction (Pin 2) High.....	30
Figure 37: MCU	34
Figure 38: Analog Switches, Protection Diodes and LEDs	35
Figure 39: Socket and Expansion Connectors	35
Figure 40: Signal Generator	36
Figure 41: Boost Converter USB Interface.....	36
Figure 42: Port Extender	36
Figure 43: USB Protection.....	37

Tables

Table 1: Available Connections for Each Test Point	13
Table 2: Pin Configuration for Counter with Clock Enable	17
Table 3: Pin Configuration for LED String with Direction	26

1 Terms and Definitions

ACMP	Analog Comparator
ADC	Analog-to-Digital Converter
BOM	Bill of Materials
GND	Ground
IDE	Integrated Development Environment
LED	Light Emitting Diode
LUT	Look Up Table
OTP	One-Time Programmable
PWM	Pulse-Width Modulation
RAM	Random-Access Memory
TP	Test Point
USB	Universal Serial Bus
V _{DD}	Power Supply

2 Introduction

Thank you for choosing Renesas Electronics Corporation's products. The GreenPAK Advanced Development Platform allows you to develop your custom design using GreenPAK mixed signal ICs. You can design your own projects starting from a blank project or by altering the sample projects provided at <https://www.renesas.com/>.

2.1 GreenPAK Designer

GreenPAK Designer is an easy-to-use full-featured integrated development environment (IDE) that allows you to specify exactly how you want the device to be configured. This provides you a direct access to all GreenPAK device features and complete control over the routing and configuration of a PAK project with just one tool.

With GreenPAK Designer, you can:

- Design the configuration which corresponds to your project needs
- Verify the project using software interface to GreenPAK Advanced Development Platform hardware
- With simple-to-use and intuitive software and hardware tools you can reduce your project development time and get to market faster

To start working with GreenPAK Designer please take the following steps:

- Download and install GreenPAK Designer software
- Configure modules that you will need for your project
- Interconnect and configure modules
- Specify the pin out
- Test your design with the GreenPAK Advanced Development Platform

2.2 Support

Free support for GreenPAK Advanced Development Platform is available online at <https://www.renesas.com/>.

GreenPAK Designer will automatically notify you when a new version of software is available. For manual updates please go to <https://www.renesas.com/software-tool/go-configure-software-hub>.

These resources are also available under the **Help** menu of GreenPAK Designer.

3 Getting Started

3.1 Introduction

This chapter describes how to install and configure the GreenPAK Advanced Development Platform. Section 4 provides the details of hardware operation. Section 5 provides instructions on how to create a simple project example.

3.2 Install Hardware

No hardware installation is required for this platform.

3.3 Install Software

GreenPAK Designer software is available free of charge from the Renesas website at <https://www.renesas.com/software-tool/go-configure-software-hub> page.

3.4 Uninstall Software

The software can be uninstalled in the way typical for your operating system. Please refer to your operating system support documentation if you need the specific instructions or visit Section 2.2 of this document for additional support from Renesas.

4 Hardware

4.1 Overview

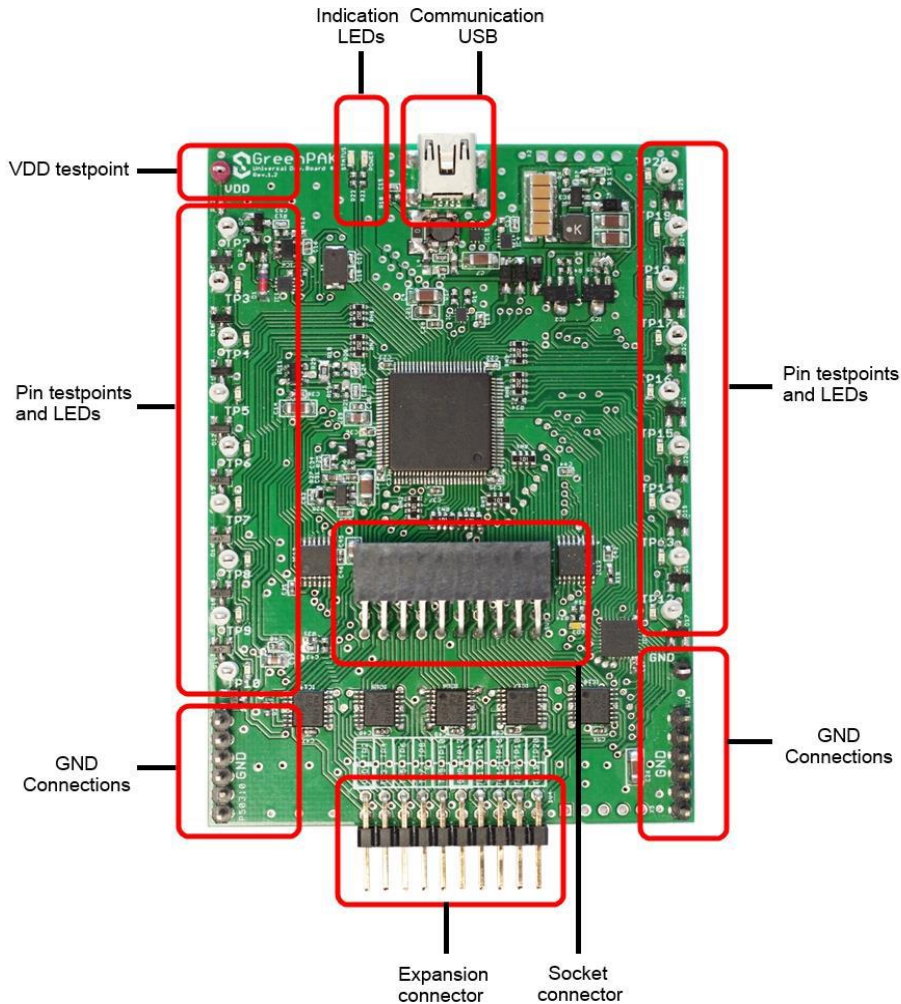

Figure 1: GreenPAK Advanced Development Board, Top View

Note: all test points were designed only for observation of signals on the pins. Please do not try to connect external power/signal source to test points, this will affect GreenPAK Advanced Development Board functionality and may even damage it.

4.2 Functional Description

4.2.1 Power Supply

The main power source of the GreenPAK Advanced Development Board is the USB power line. The Development Board can deliver power from 0 to 5.5 V. To provide this power range, the Development Board is equipped with a boost converter. A Signal generator with a buffered output controls the GreenPAK chip power rail. For more information about GreenPAK electrical specification, please refer to the datasheet.

4.2.2 USB Communication

The board has the USB communications interface that uses the USB mini-B connector, as shown in [Figure 2](#). This interface provides communication with the software control tool and supplies power to the platform, as discussed in [4.2.1](#).



Figure 2: USB Interface

4.2.3 GND Connections

There are 6 GND pins on the left side, 6 pins and 1 header on the right side. These can be used for test equipment (oscilloscope, multimeter, and others) ground reference connection or to connect external test circuitry ground.

4.2.4 Pin Test Points

Each GreenPAK chip pin including V_{DD} has its own observation test point. These test points were designed only for observation. To connect an external signal source use a software-controlled expansion connector.

4.2.5 LEDs

All the pins except Pin 2 can be connected to buffered LEDs. This option allows visualization of digital levels on chip pins. There are 2 selection modes:

- Buffered LED (with high impedance input)
- Inverted Buffered LED (with high impedance input)

This option can be enabled in GreenPAK Designer.

4.2.6 Socket Connector

The GreenPAK Advanced Development Board should be used with a detachable socket board. Its main purpose is to connect the GreenPAK chip to the Development Board. It's easy to use the programmed chip in external circuits, or to measure current consumption of the project.

4.2.7 Expansion Connector

This port was designed to connect the GreenPAK Advanced Development Board to external circuits and apply external power, signal sources and loads. It can be used to apply the GreenPAK chip into your custom design with minimal additional tools. For schematic diagram refer to [Figure 3](#).

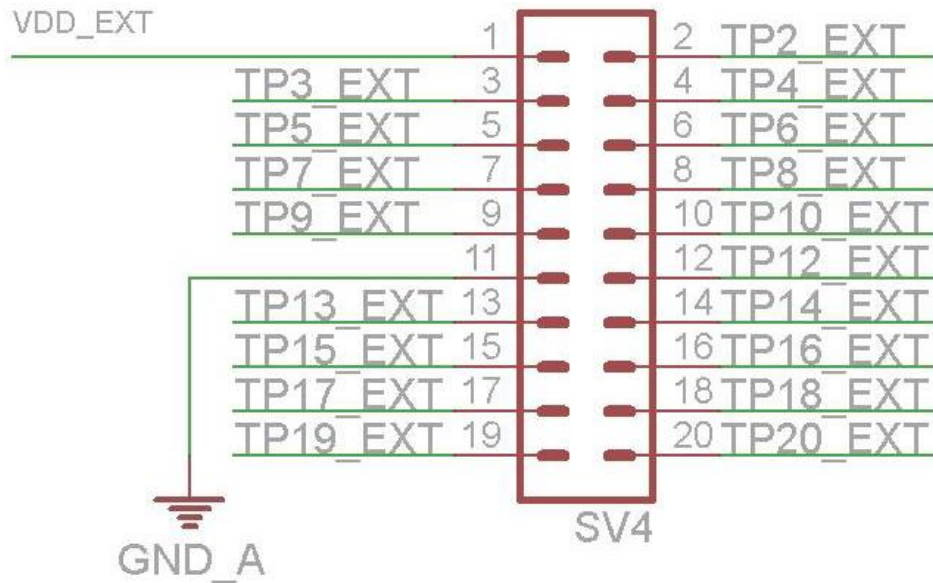

Figure 3: GreenPAK Expansion Connector Schematic

Each pin except Pin 11 (GND) is controlled through an individual analog switch. Expansion connector is a standard 0.1” double row connector. GreenPAK Designer can enable or disable external pins, as it is shown in the Figure 4. The main purpose of the Expansion connector is to connect an external signal/power source safely to the GreenPAK Advanced Development Board.

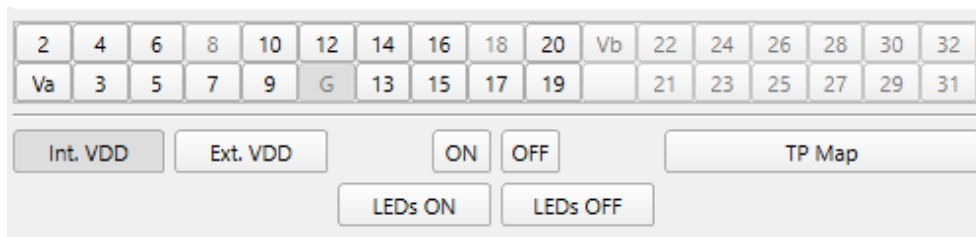

Figure 4: Expansion Connector Control in GreenPAK Designer

Figure 5 demonstrates the schematic diagram of the expansion connector control.

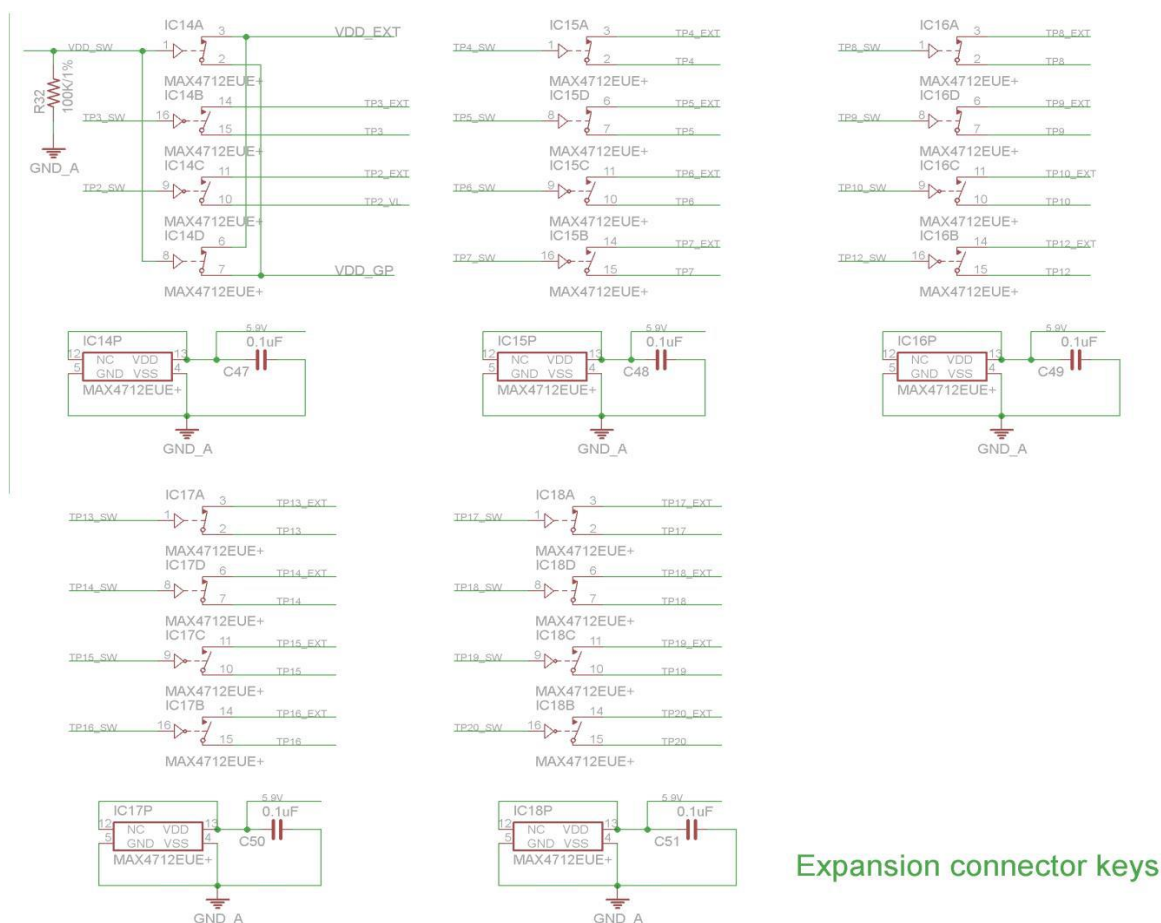

Figure 5: Socket and Expansion Connector Schematic

Expansion connector is enabled only in Emulation mode or Test mode. To enter either of these two modes the GreenPAK chip must be in the socket. When the Test mode button is pressed the software will first read the chip to verify if it was inserted and then configure the GreenPAK Advanced Development Board as set in Emulation Tool window. When the Test mode button is gray then the Development Platform is in Default state and all expansion port switches are open (disconnected). After Emulation button is pressed, the software will automatically perform the following steps:

- check chip presence
- open all expansion port switches (external signals/loads can be left connected to expansion port)
- use internal power and load configuration to the chip
- only for case #3: adjust internal power source to external power level → close external power switch → open internal power switch
- configure Development Board as set in Emulation Tool window

Parasitic effects should be also considered while using the GreenPAK Advanced Development Board in-circuit with analog signals. The entire Development Board circuitry along with the wiring have a significant amount of mutual capacitance and inductance. The detachable socket can also be used for the in-circuit development with programmed chips (the Development Board and socket connectors have the same pinout).

The GreenPAK Advanced Development Board provides three possible ways of using expansion connector:

- 1) Internal power is used to run the chip, no external power output is needed, external signal sources and loads can be connected between pins and GND.

The configuration steps:

- close internal and open external power switch
- close all used expansion port switches in the software
- hit Emulation/Test mode button

This is the common way of using an Expansion connector.

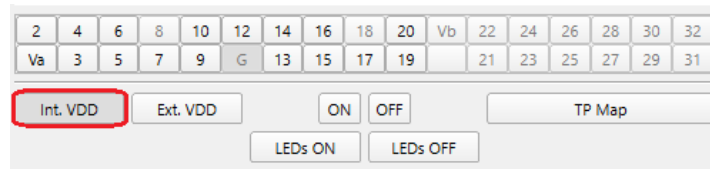

Figure 6: Internal Power Source

2) Internal power is used to run the chip and external circuit (internal power source/sink current is limited to 50 mA).

The configuration steps:

- close internal power switch
- close external power switch
- close all used expansion port switches in the software
- hit Emulation/Test mode button

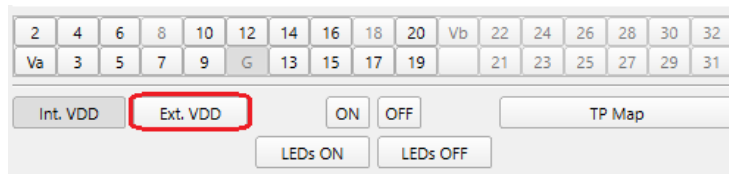

Figure 7: Internal Power Source for GreenPAK Chip and External Development Platform

3) External power is used to run the chip and external circuit (internal source output is in Hi-Z state). The configuration steps:

- open internal power switch
- close external power switch
- close all used expansion port switches in the software
- hit Emulation/Test mode button (External power should be applied before this step)

Note that the GreenPAK chip has internal OTP memory which is normally loaded into RAM registers at initialization time. “Emulation mode” will bypass this load, and write the updated version of the project directly into the RAM register inside the GreenPAK chip many times, but after power loss all internal data will be lost. When the GreenPAK chip is already programmed the user can use Emulation mode to load another project and test it on the emulation tool in Emulation mode, in that case emulation data will be cleared. The “Emulation” mode is not necessary for checking programmed parts: in this case the “Test mode” is used.

Expansion connector can be divided by types of connections:

1. V_{DD}
2. GND
3. Data connections

The V_{DD} connection enables the user to connect/disconnect external and internal power source. This connection meets next requirements:

- External power range: 1.8 - 5.5 V
- High resistance voltage dividers are not recommended

GreenPAK Advanced Development Platform

The GND connection is connected directly to the Development Board, and cannot be controlled by GreenPAK Designer.

Data connections are the easiest way to connect external lines to the GreenPAK chip. They are software controlled switches. Every line is connected with a 100 W resistor.

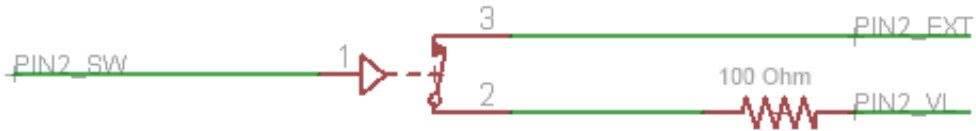

Figure 8: Expansion Connector. Pin with Protection Resistor

4.2.8 Generators

Three types of generator can be connected to a defined TP: Logic generator, Signal generator, or I²C generator. The user can add generator to highlighted green pins with the help of Add button or use a context menu of the TP.

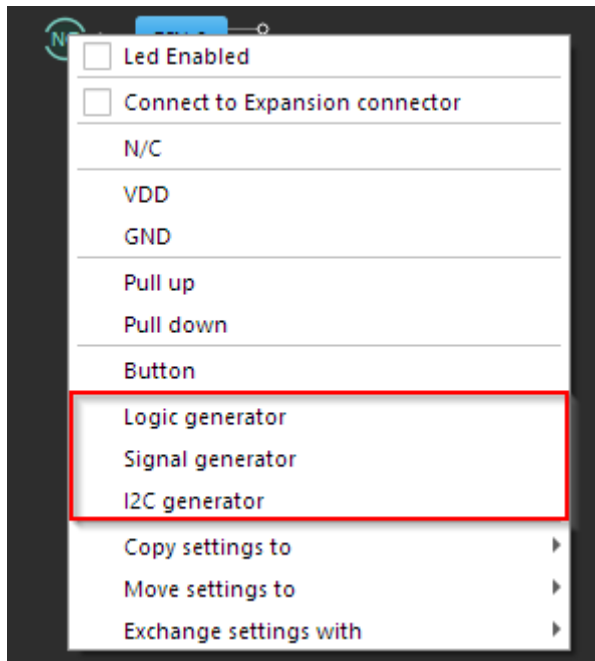

Figure 9: Choosing Generators

Logic generator is used for generating logic pulses.

I²C generator allows the user to create I²C signals based on logic generators. There are two logic generators combined together as SDA and SCL lines. The user can combine predefined I²C settings to generate a needed waveform and choose SCL frequency.

SCL sends I²C-compatible SCL signal to the line. SCL works only in a 'read-only' mode. SCL clock can be configured by choosing predefined frequency. The set of those frequencies depends on the development platform.

SDA sends I²C-compatible SDA signal to the line. In Signal Wizard special editor shows sequence of commands. There are some actions in command editor the user can do.

Signal generator is used to generate analog signals: constant voltage level, sine, trapeze (trapezoid), logic pattern, and user-defined.

There is a possibility to start all the generators using buttons at Debugging controls panel.

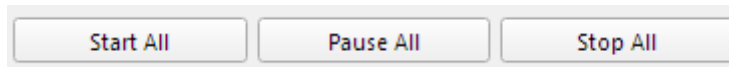

Figure 10: Managing Buttons

Note: these buttons can be controlled only by generators with installed Global Linkage flag.



Figure 11: Global Linkage Settings

4.2.9 Pins Connectivity

The GreenPAK Advanced Development Board supports connecting eight types of loads and signal sources. Each source has its own special purpose. The List of available connections for each test point is presented in Table 1.

Table 1: Available Connections for Each Test Point

Pin	Set to V _{DD}	Set to GND	Pull-up	Pull-down	Set Configurable Button	LED	Signal Generator	Logic Generator	I ² C Generator
#	1	2	3	4	5	6	7	8	
V _{DD}	-	-	-	-	-	-	+	-	-
TP2	+	+	+	+	+	-	-	+	+
TP3	+	+	+	+	+	+	-	+	+
TP4	+	+	+	+	+	+	-	+	+
TP5	+	+	+	+	+	+	-	+	+
TP6	+	+	+	+	+	+	+	+	+
TP7	+	+	+	+	+	+	+	+	+
TP8	+	+	+	+	+	+	+	+	+
TP9	+	+	+	+	+	+	-	+	+
TP10	+	+	+	+	+	+	+	+	+
TP12	+	+	+	+	+	+	+	+	+
TP13	+	+	+	+	+	+	+	+	+
TP14	+	+	+	+	+	+	+	+	+
TP15	+	+	+	+	+	+	-	+	+
TP16	+	+	+	+	+	+	-	+	+
TP17	+	+	+	+	+	+	-	+	+
TP18	+	+	+	+	+	+	-	+	+
TP19	+	+	+	+	+	+	-	+	+
TP20	+	+	+	+	+	+	-	+	+

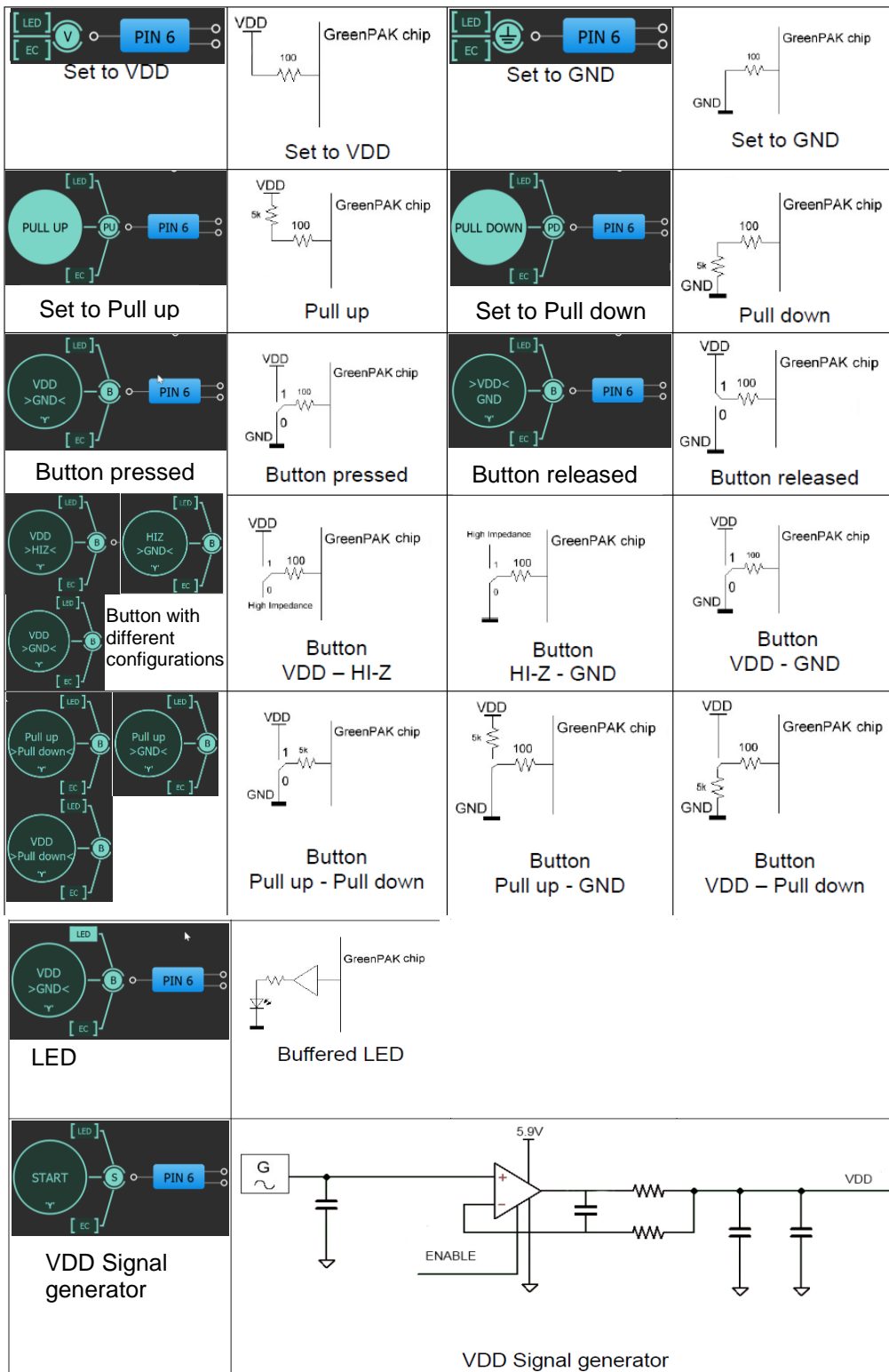

Figure 12: Pin Signal Sources/Loading Schematics

Note: V_{DD} Signal generator works similar to other Signal generators but has wider output voltage range. It can provide maximum supply level of 5.5 V.

5 Example Projects using SLG46721

5.1 Project: Counter with Clock Enable

Blocks required:

- 2 digital inputs
- 1 digital output
- 1 Look Up Table with two inputs
- 1 Counter

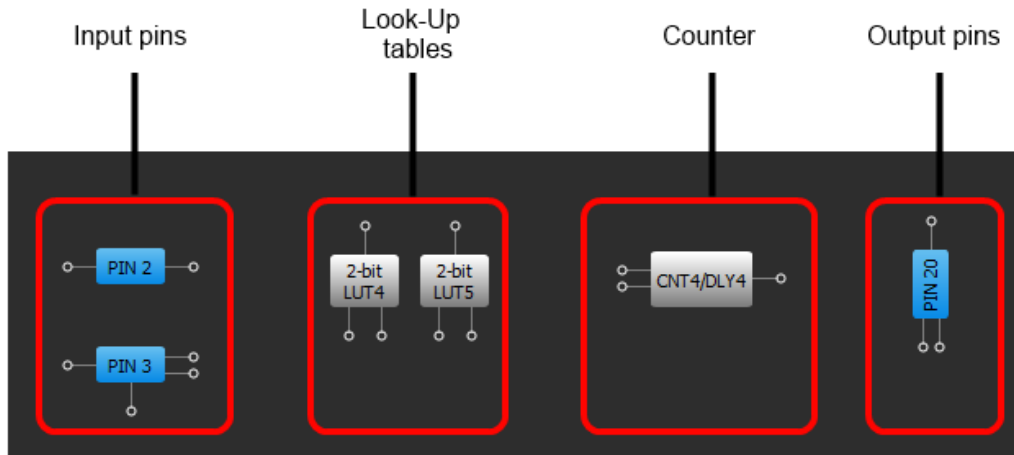

Figure 13: GreenPAK Designer

GreenPAK Advanced Development Platform

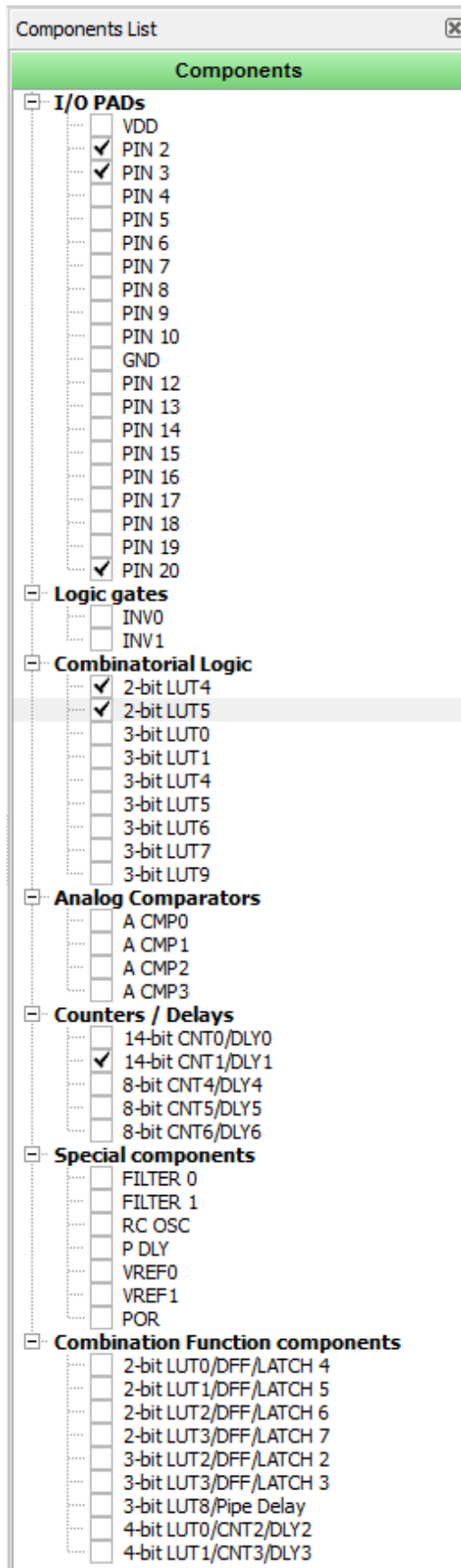

Figure 14: GreenPAK Components List

GreenPAK Advanced Development Platform

All these components can be found in components list. If there are no components on the work area - make sure this component is enabled.

Table 2: Pin Configuration for Counter with Clock Enable

Pin #	Pin Name	Type	Pin Description
1	V _{DD}	PWR	Supply Voltage
2	Clock	Digital input	Digital input
3	Enable	Digital Input	Digital Input
11	GND	GND	Ground
20	Counter Output	Push-Pull output	Digital input

All components used in the project are shown in [Figure 13](#), next step is to configure selected blocks. Double click on Pin 20 to open “Properties” panel. Select “1x push pull” from the drop-down menu in Pin 20 properties and hit “Apply” button.

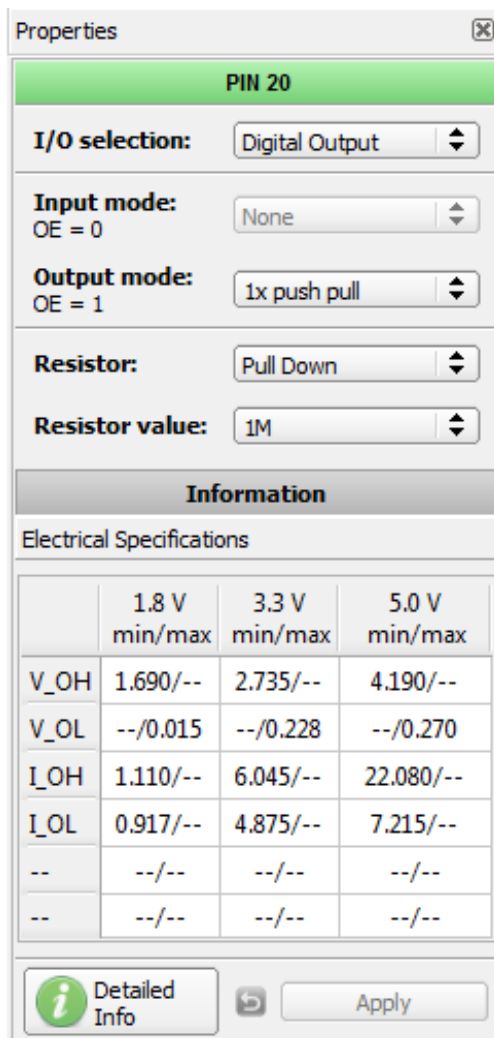

Figure 15: Pin 20 Mode

GreenPAK Advanced Development Platform

The next component in this design is the Look Up Table. First Look Up Table (LUT4) is used to generate logic “1” only when there are high logic levels on both inputs (AND gate). Select AND gate from “Standard gates” drop-down menu or set table manually. Second Look Up Table (LUT5) is configured as NOR gate. It is used to generate reset signal for counter on Pin 3 falling edge.

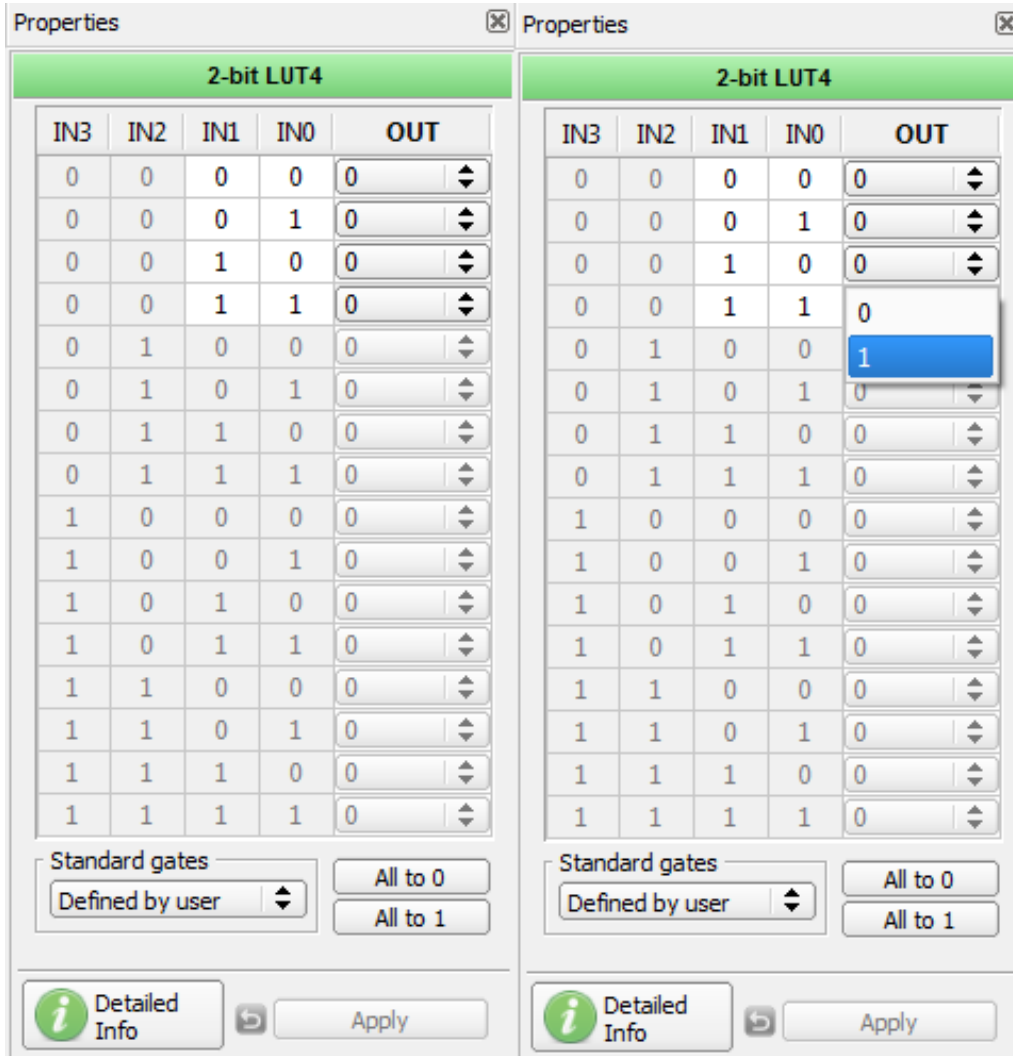

Figure 16: Look Up Table Properties Configured as AND Gate

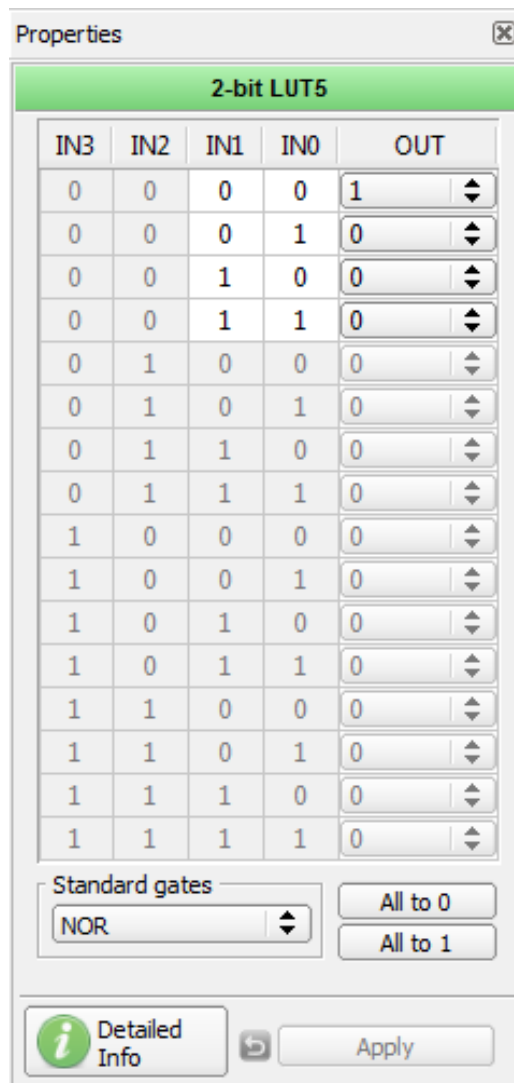

Figure 17: Look Up Table Properties Configured as NOR Gate

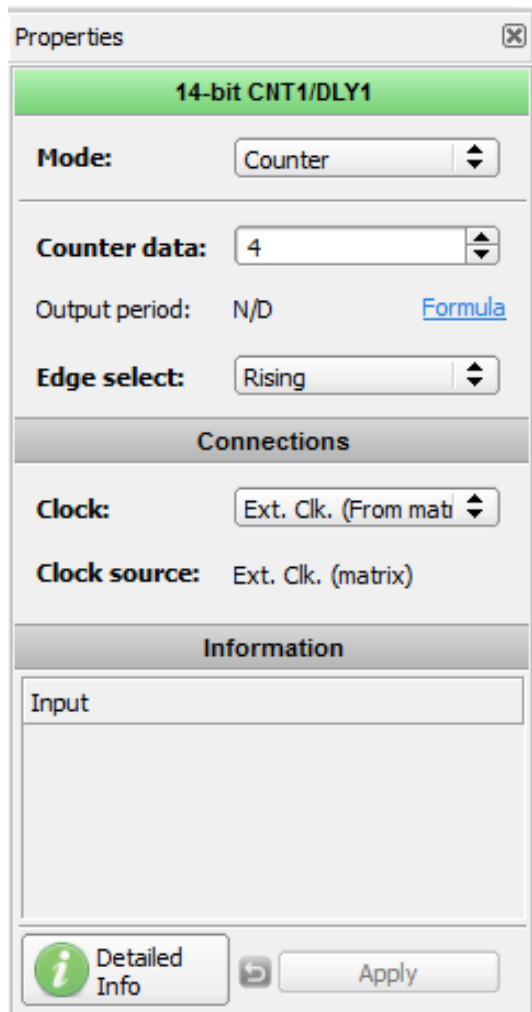



Figure 18: Counter Properties

The final step is to connect used components. Use Wire tool to perform this action. To connect two pins select “Set Wire”  and then click on the first and the second pin of the module or modules that you want to connect. The trace will be automatically routed.

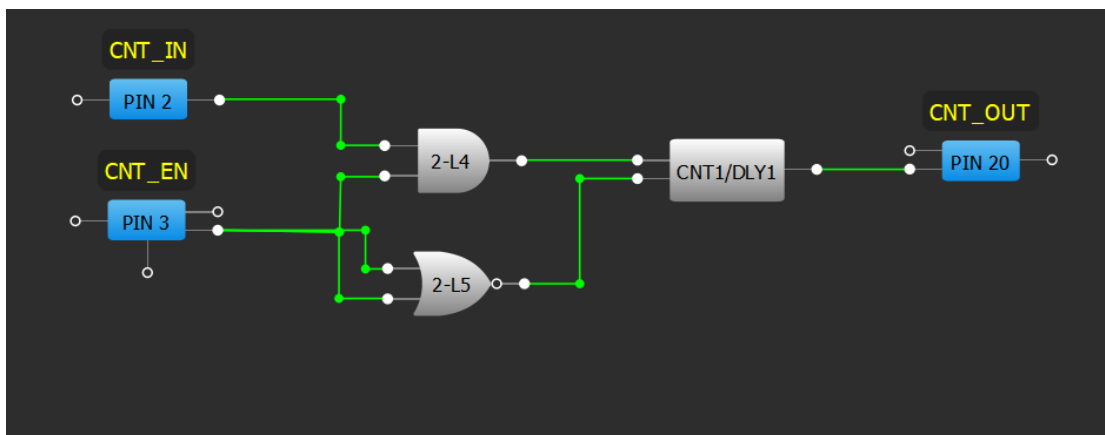

Figure 19: GreenPAK Designer

Figure 19 displays ready project with configured blocks and wire connections.

GreenPAK Advanced Development Platform

Use the GreenPAK Advanced Development Board to test this project. Connect the GreenPAK Advanced Development Board to the PC and press “Emulation” button. This will load the code of your project to the chip and will enable Test functionality of your Development Board.

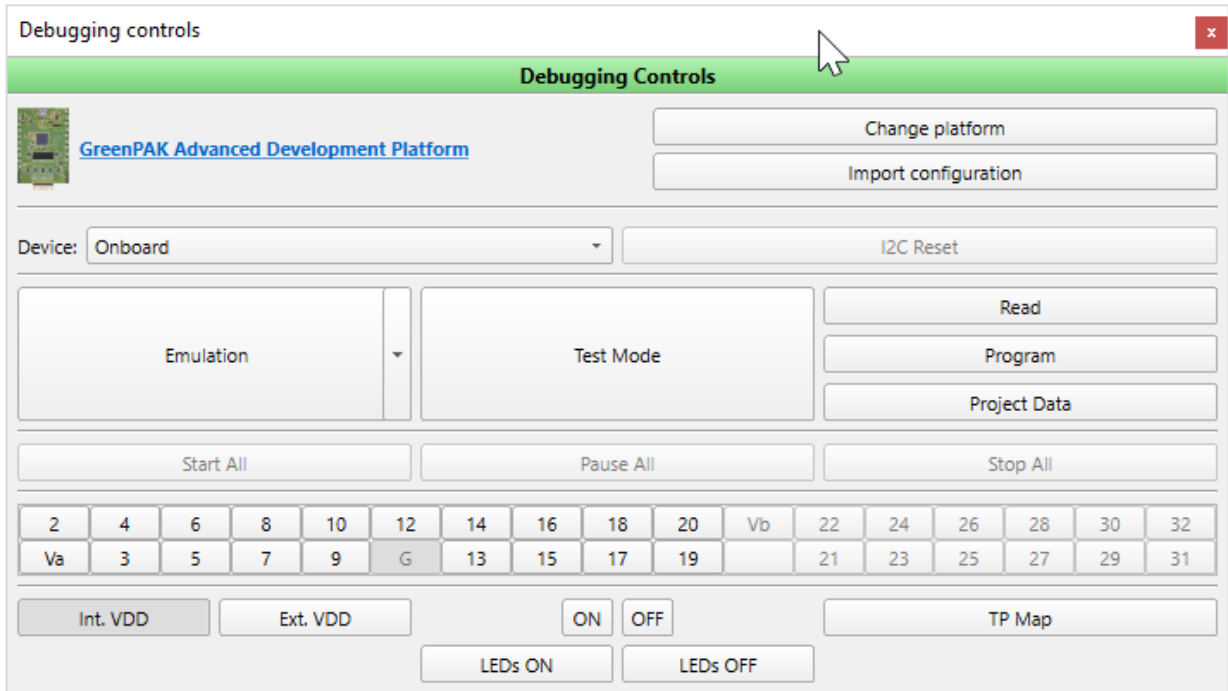

Figure 20: GreenPAK Designer, Emulation Tool

To test this project we will use the following tools:

- Signal generator. Signal generator is applied to V_{DD} pin to power GreenPAK chip
- Logic generator. Logic generator serves as clock source
- Button is a software simulation of the real button. It switches Pin between V_{DD} and GND signal levels
- Inverted buffered LED
- Buffered LED

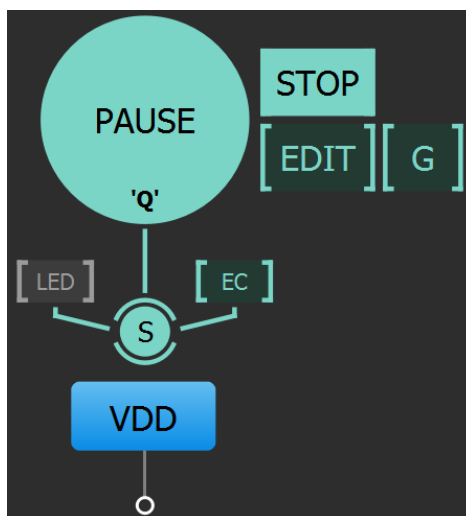

Figure 21: Signal Generator Connected to V_{DD} Pin

Signal generator is presented as a power source for GreenPAK chip. It's configured to output source constant 3.3 V.

Options	
General	
Generator:	PIN1 (VDD) - Constant Voltage L ▾
Shown period:	Auto ▾
Start point:	0.000 ▾ ms ▾
Stop point:	0.100 ▾ ms ▾
Global linkage:	Unlinked ▾
Sync Power Rails:	Disabled ▾
Repeat:	Cyclic ▾
Repeat count:	2 ▾
Pre-start state:	Start point (V0) ▾
Pre-start delay:	0.000 ▾ ms ▾
End state:	Pre-start state ▾
Output type:	High-Z ▾
Pause type:	Last state ▾
Signal Generator Settings	
Type:	Const. voltage ▾
U:	3.299 ▾ V ▾
Tolerance: ±30 mV	

Figure 22: Signal Generator Settings

The purpose of the logic generator is to provide clock pulses for the Counter block. It is configured for 10 Hz clock source as shown in the [Figure 23](#).

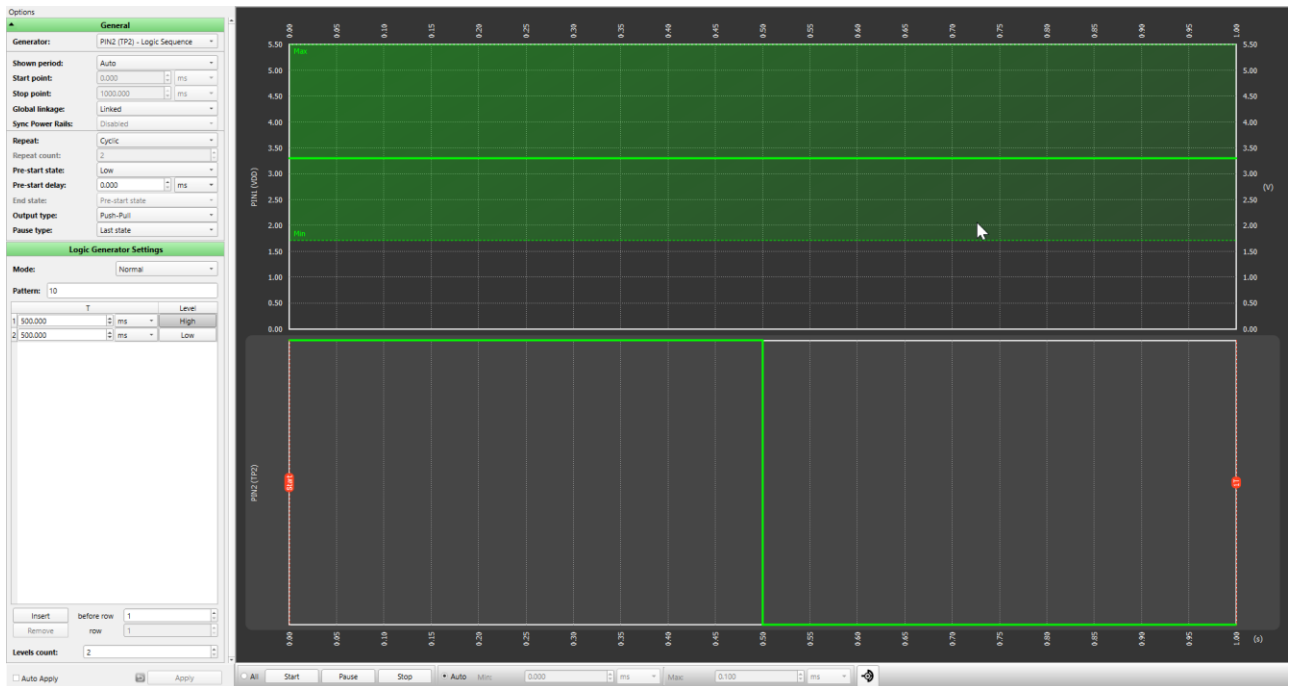

Figure 23: Logic Generator Properties

Functionality Waveform

Channel 1 (yellow/top) – Logic generator
 Channel 2 (light blue/2nd line) – Button, 1 - enable Counter; 0 - disable Counter
 Channel 3 (magenta/3rd line) – Counter output

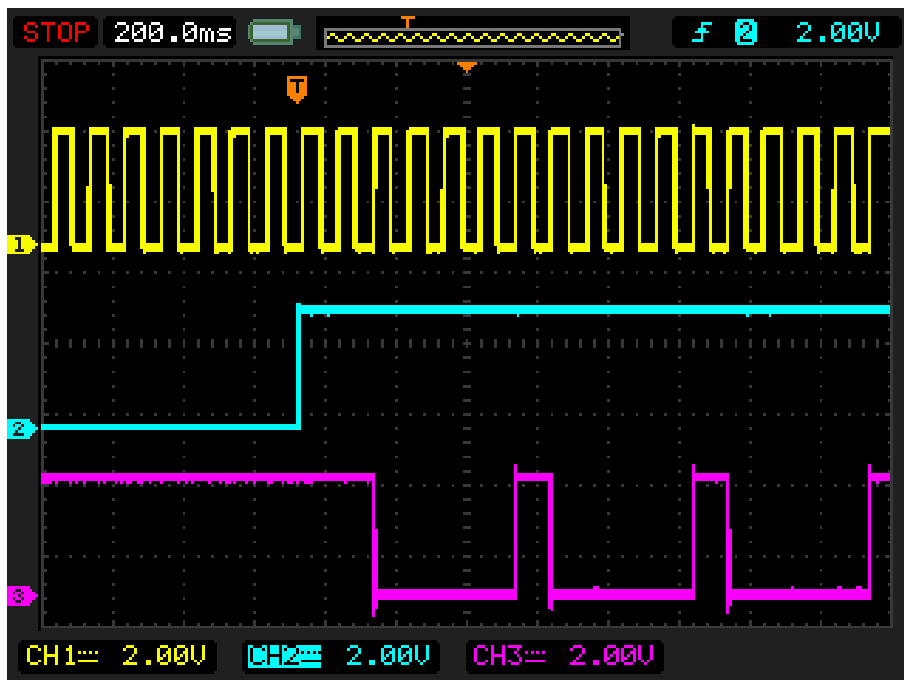

Figure 24: Waveform, Triggered on Button Pressed

Channel 1 (yellow/top) – Logic generator
 Channel 2 (light blue/2nd line) – Button, 1 - enable Counter; 0 - disable Counter
 Channel 3 (magenta/3rd line) – Counter output

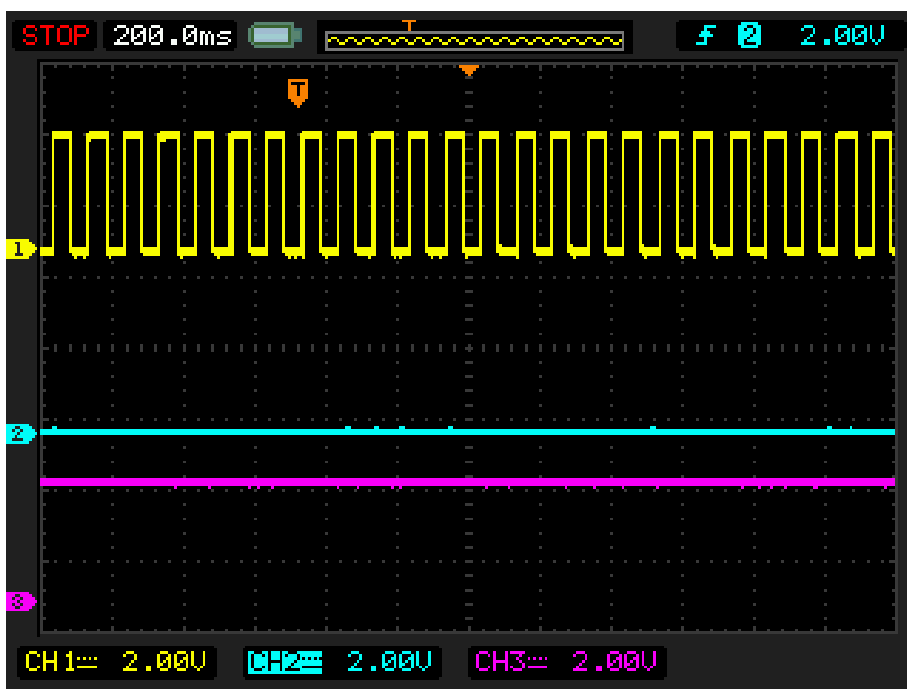

Figure 25: Waveform, no Triggered on Button Released

Channel 1 (yellow/top) – Logic generator
 Channel 2 (light blue/2nd line) – Button, 1 - enable Counter; 0 - disable Counter
 Channel 3 (magenta/3rd line) – Counter output

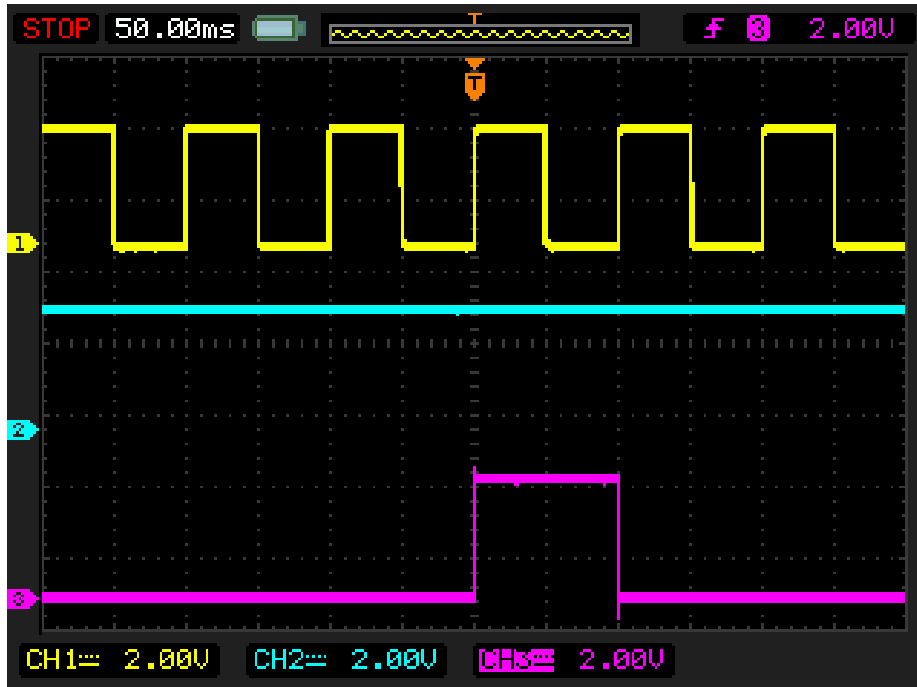

Figure 26: Waveform of the Pulse Width of the Logic Generator and Count End Signal

As shown in [Figure 25](#) and [Figure 26](#) Counter works only when the button is pressed.

5.2 Project: LED String with Direction

For this project we will need:

- Analog pin for input data
- Digital pin for PWM output
- ADC block
- PWM block

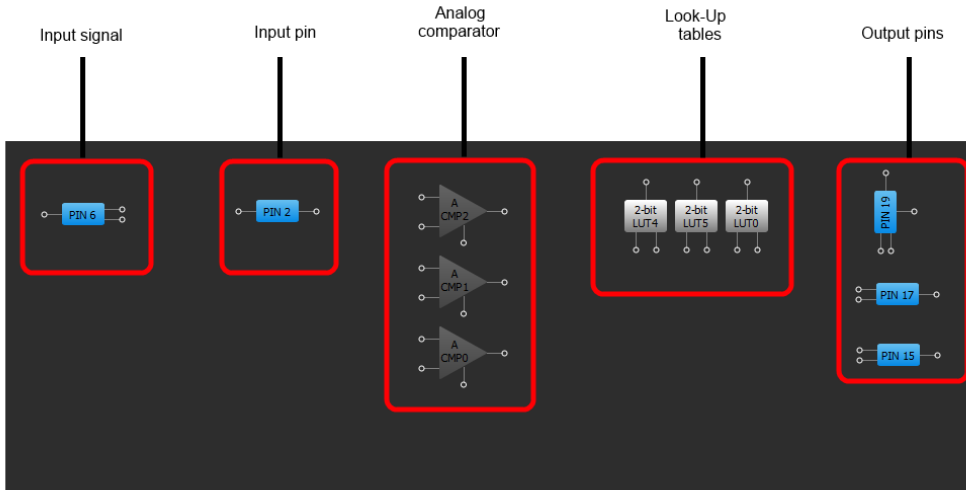

Figure 27: Used Blocks for Current Project

For testing this project, the Signal generator with sine waveform is used.

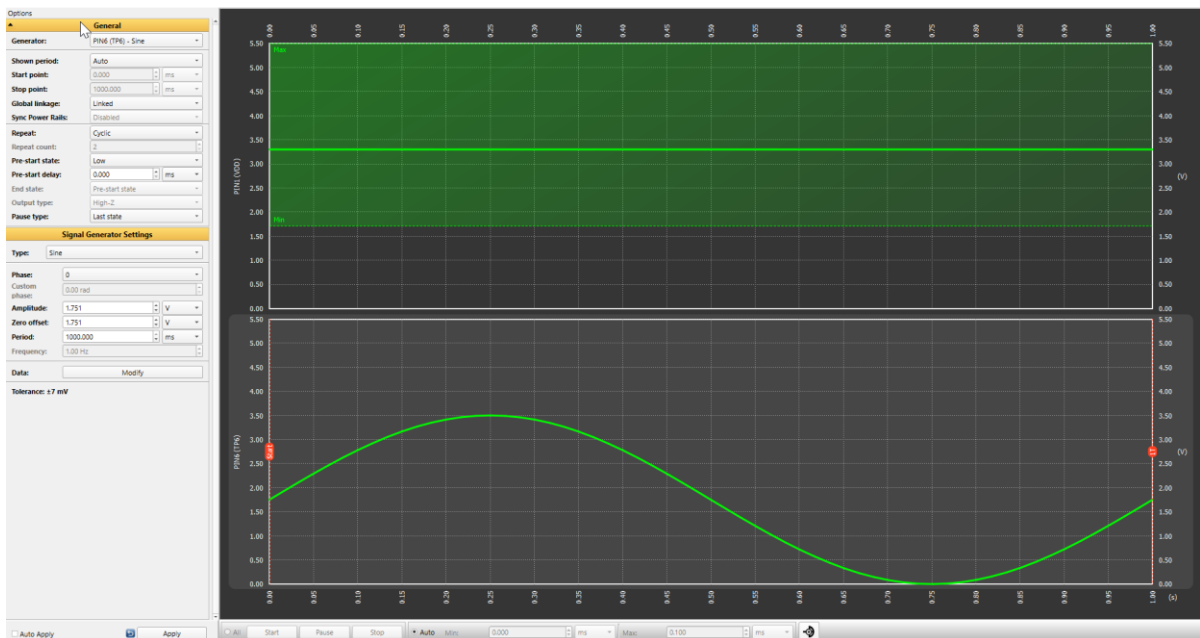

Figure 28: Sine Waveform Generated with Signal Generator

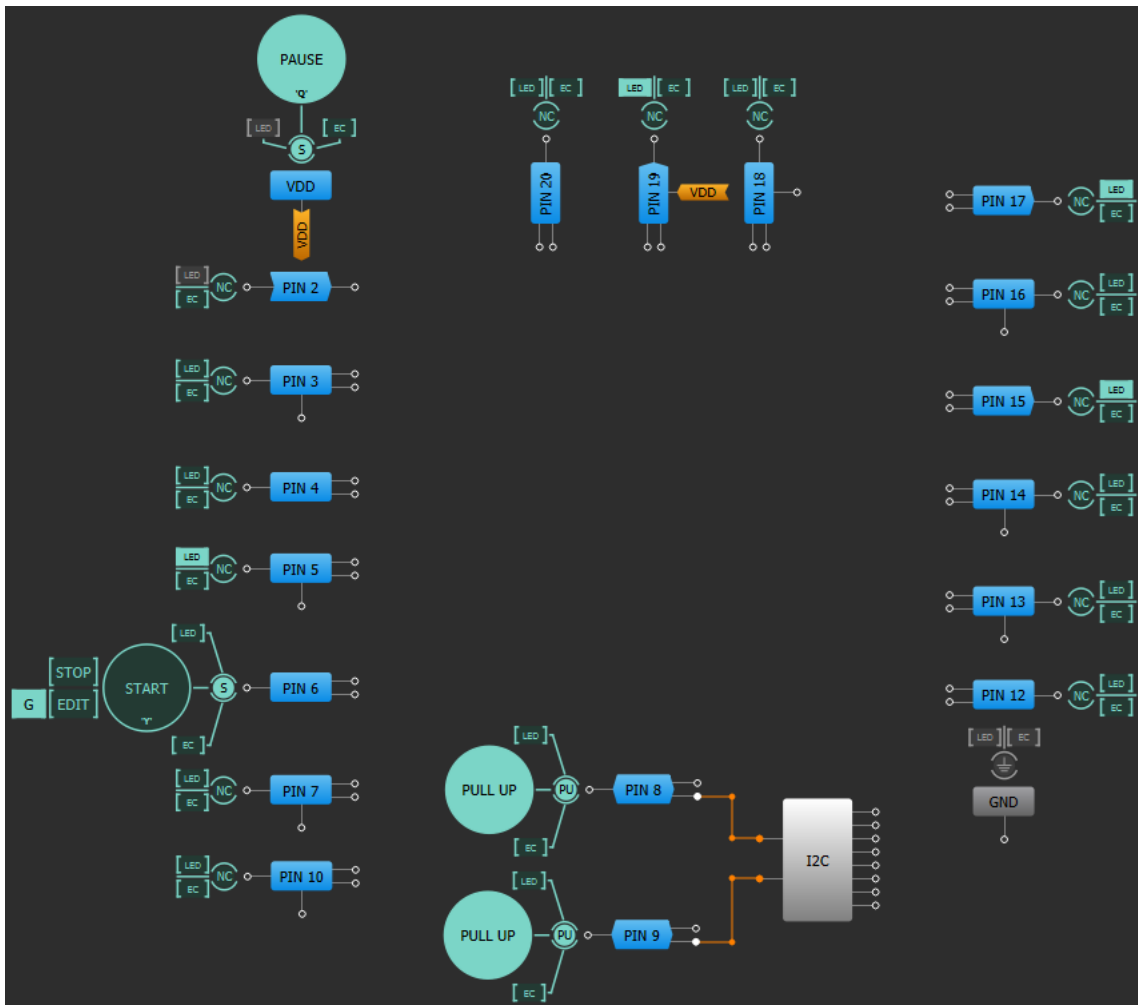

Figure 29: Emulation Window, with Buffered LED and Signal Generator

Table 3: Pin Configuration for LED String with Direction

Pin #	Pin Name	Type	Pin Description
1	V _{DD}	PWR	Supply Voltage
2	DIRECTION	Input	Controls direction
6	SIGNAL	Input	Analog Input
11	GND	GND	Ground
15	LED_A	Output	LED
17	LED_B	Output	LED
19	LED_C	Output	LED

GreenPAK Advanced Development Platform

Properties [X]

PIN 2

I/O selection: Digital Input

Input mode: Digital in without Sc
OE = 0

Output mode: None
OE = 1

Resistor: Pull Down

Resistor value: 1M

Information

Electrical Specifications

	1.8 V min/max	3.3 V min/max	5.0 V min/max
V _{IH}	1.100/--	1.780/--	2.640/--
V _{IL}	--/0.690	--/1.210	--/1.840
--	--/--	--/--	--/--
--	--/--	--/--	--/--
--	--/--	--/--	--/--
--	--/--	--/--	--/--

[i] Detailed Info [Apply]

Figure 30: Pin Properties

Pin 6 is configured as analog input-output. This pin is used for generating SINE waveform.

Properties PIN 6

I/O selection: Analog Input/Output

Input mode: Analog input (OE = 0)

Output mode: Analog output (OE = 1)

Resistor: Pull Down

Resistor value: 1M

Information

Electrical Specifications

	1.8 V min/max	3.3 V min/max	5.0 V min/max
--	--/--	--/--	--/--
--	--/--	--/--	--/--
--	--/--	--/--	--/--
--	--/--	--/--	--/--
--	--/--	--/--	--/--
--	--/--	--/--	--/--

Properties PIN 19

I/O selection: Digital Output

Input mode: None (OE = 0)

Output mode: 1x push pull (OE = 1)

Resistor: Pull Down

Resistor value: 1M

Information

Electrical Specifications

	1.8 V min/max	3.3 V min/max	5.0 V min/max
V_OH	1.690/--	2.735/--	4.190/--
V_OL	--/0.015	--/0.228	--/0.270
I_OH	1.110/--	6.045/--	22.080/--
I_OL	0.917/--	4.875/--	7.215/--
--	--/--	--/--	--/--
--	--/--	--/--	--/--

Figure 31: Pin Properties

Properties 2-bit LUT4

IN3	IN2	IN1	IN0	OUT
0	0	0	0	0
0	0	0	1	1
0	0	1	0	1
0	0	1	1	0
0	1	0	0	0
0	1	0	1	0
0	1	1	0	0
0	1	1	1	0
1	0	0	0	0
1	0	0	1	0
1	0	1	0	0
1	0	1	1	0
1	1	0	0	0
1	1	0	1	0
1	1	1	0	0
1	1	1	1	0

Standard gates: XOR, All to 0, All to 1, Invert, Regular shape

Properties 2-bit LUT5

IN3	IN2	IN1	IN0	OUT
0	0	0	0	0
0	0	0	1	1
0	0	1	0	0
0	0	1	1	0
0	1	0	0	0
0	1	0	1	0
0	1	1	0	0
0	1	1	1	0
1	0	0	0	0
1	0	0	1	0
1	0	1	0	0
1	0	1	1	0
1	1	0	0	0
1	1	0	1	0
1	1	1	0	0
1	1	1	1	0

Standard gates: XOR, All to 0, All to 1, Invert, Regular shape

Properties 2-bit LUT0/DF/LATCH4

Type: LUT

IN3	IN2	IN1	IN0	OUT
0	0	0	0	0
0	0	0	1	1
0	0	1	0	1
0	0	1	1	0
0	1	0	0	0
0	1	0	1	0
0	1	1	0	0
0	1	1	1	0
1	0	0	0	0
1	0	0	1	0
1	0	1	0	0
1	0	1	1	0
1	1	0	0	0
1	1	0	1	0
1	1	1	0	0
1	1	1	1	0

Standard gates: XOR, All to 0, All to 1, Invert, Regular shape

Figure 32: Look Up Tables Properties Configured as XOR Gate

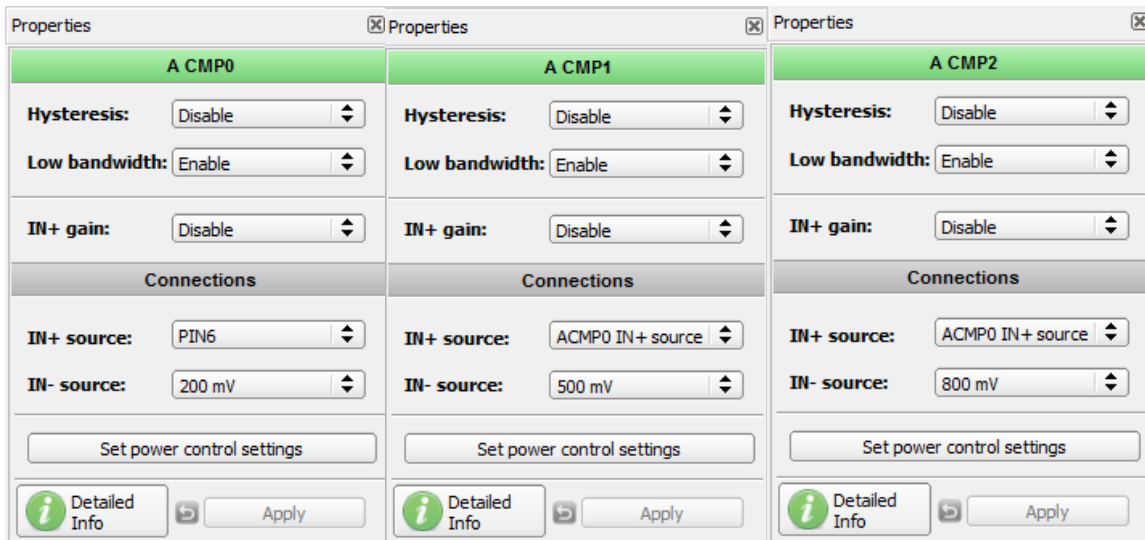

Figure 33: ACMP Properties

Pins 15, 17, 19 - configured as output with Push-Pull 1x. They are used for testing purpose.

All comparators positive inputs are connected to the Pin 6 analog input. When the voltage on the positive input is higher than the voltage on the negative input, comparator will set logic “1” on its output. ACMP0 positive input is 200 mV, ACMP1 is 500 mV, and ACMP2 is 800 mV, creating 4 states:

- All LEDs are off
- LED_A is on
- LED_A and LED_B are on
- All LEDs are on

If Pin 2 logic level is set to “1”, these states will transform into:

- All LEDs are on
- LED_A and LED_B are on
- LED_A is on
- All LEDs are off

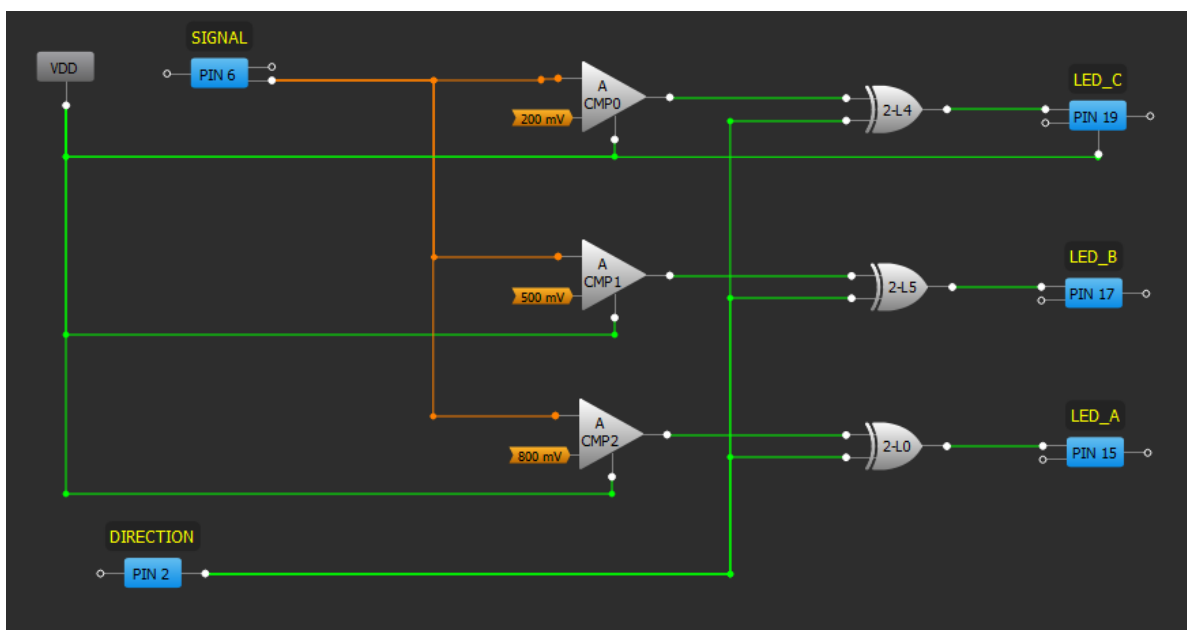

Figure 34: GreenPAK Designer

Functionality Waveform

- Channel 1 (yellow/top) – Direction
- Channel 2 (light blue /2nd line) – LED_A
- Channel 3 (magenta/3rd line) – LED_B
- Channel 4 (blue / 4th line) – LED_C

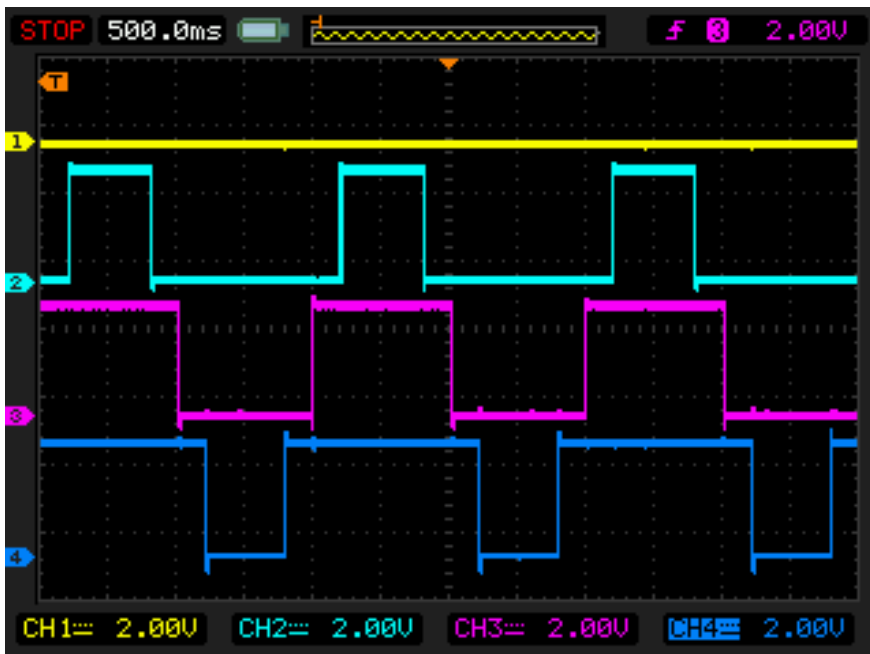

Figure 35: LED Output with Direction (Pin 2) Low

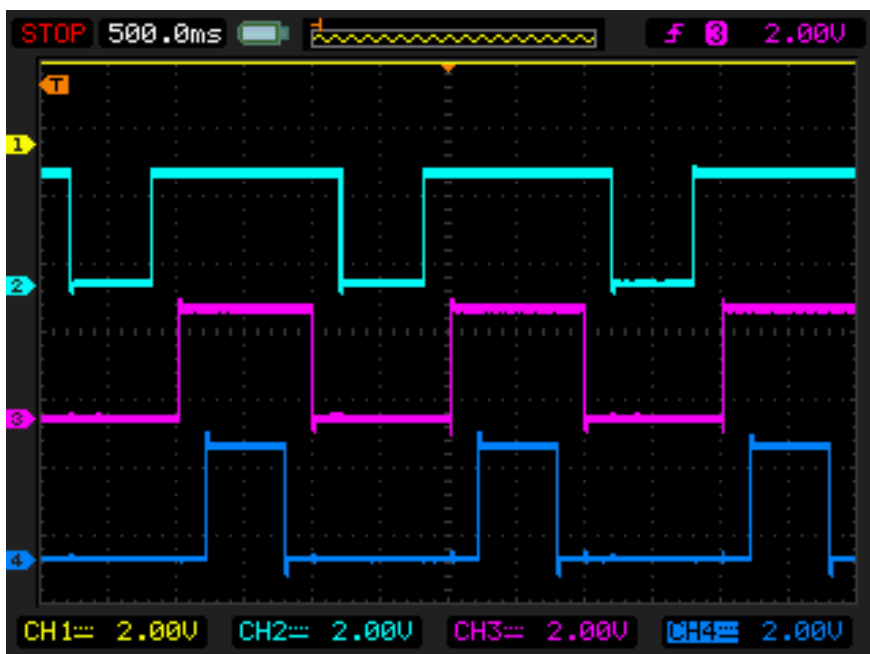

Figure 36: LED Output with Direction (Pin 2) High

The PWM duty cycle rises up to 100% when analog signal is close to 1 V.

6 Conclusion

This Development Platform is a truly versatile tool. It allows the designer to create a custom project within minutes, without using additional devices (except oscilloscope).

For more information please visit our website <https://www.renesas.com/>.

Appendix A Electrical Specification

Mode	Parameter	Min	Typ	Max	Units
General	Test Point Capacitance	19.5	--	--	pF
	Input Leakage Current	--	--	14	nA
	Max Current through Protection Diode to V _{DD}	--	--	200	mA
	Ripple & Noise	20	--	40	mVp-p
V _{DD} Power Supply Generator (V _{DD})	Voltage Range	1.5	--	5.5	V
	V _{DD} Max Current	--	--	70	mA
	Voltage Output Total Error	--	±30	--	mV
Logic generator	Number of Channels (TP2 to TP10, TP12 to TP20)	--	--	18	--
	Output Voltage High	--	V _{DD}	--	V
	Output Voltage Low	0.4	--	0.8	V
	Max Current per TP	--	--	30	mA
	Max Total Current per TPs	--	--	250	mA
	Rise Time	4	--	75	ns
	Fall Time	4	--	60	ns
	Full-Scale Settling Time (0 to 5.5 V)	30	40	75	ns
	Max Output Frequency	0.152	--	5000	Hz
	Max Number of Points	--	--	180	--
	Sample Rate	--	10	--	kSPS
Signal Generator	Number of Channels (TP3 to TP10, TP12 to TP18)	--	--	15	--
	Output Voltage Range	0	--	5.5	V
	DC Output Impedance	--	0.5	--	Ω
	Short-Circuit Current	--	--	30	mA
	Min Output Voltage	--	--	19	mV
	Output Total Error	--	--	±7	mV
	Output Frequency (SINE)	0.01	--	2500	Hz
	Max Number of Points	--	--	60	--
Virtual Button, V _{DD} /GND, Pull-Up/Down Driver	Output Level High	--	V _{DD}	--	--
	Output Level Low	--	GND	--	--
	Strong Drive (V _{DD} /GND) Resistance	--	100	--	Ω
	Pull-Up/Down Resistance	3.5	5.6	8.5	kΩ
Expansion Connector Switch	Max Voltage	--	--	5.5	V
	Continuous Current through Any Terminal	--	--	±30	mA
	Switch On-Resistance	--	20	40	Ω
	External V _{DD} Switch On-Resistance	--	10	20	Ω
	On Leakage Current	-20	--	20	nA

Mode	Parameter	Min	Typ	Max	Units
Expansion Connector Switch	Off Leakage Current	-10	--	10	nA
	Bandwidth	--	--	10	MHz
	Max V _{DD} Supply from External Source	--	--	5.66	V

Appendix B Schematic Diagram

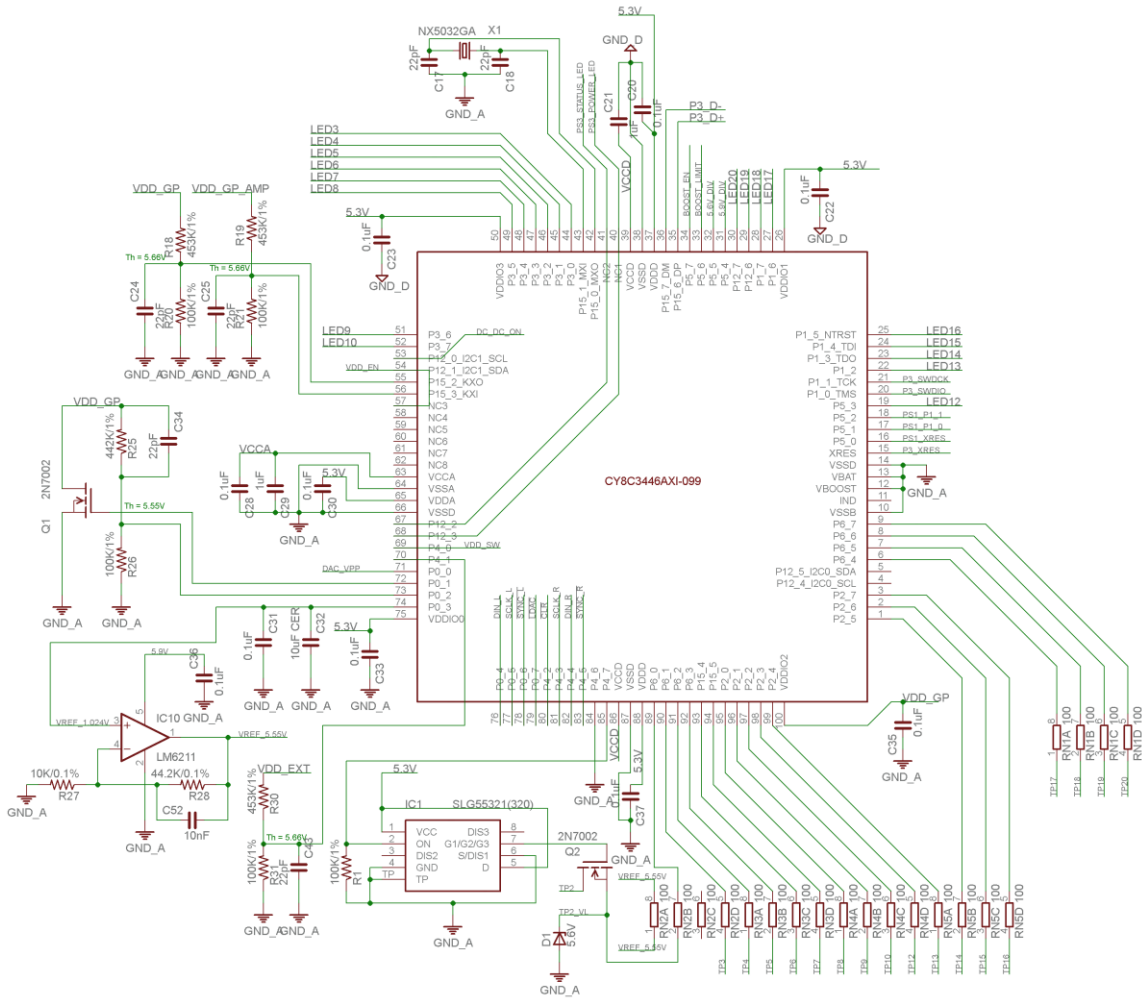

Figure 37: MCU

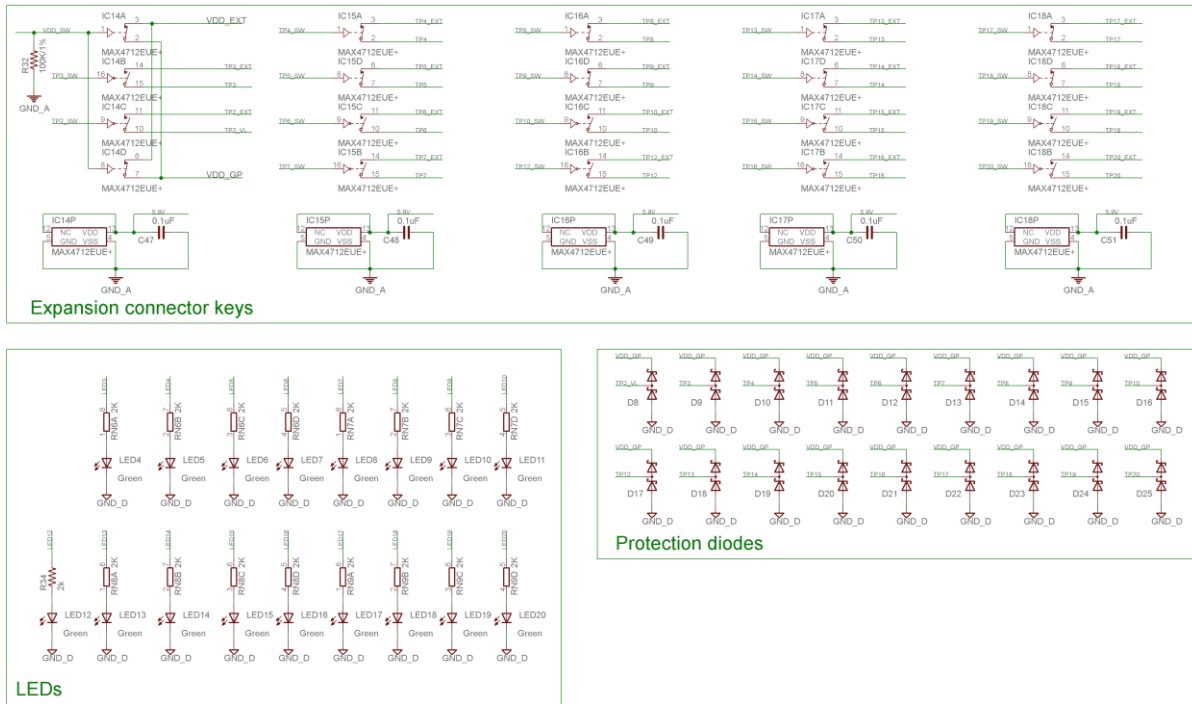
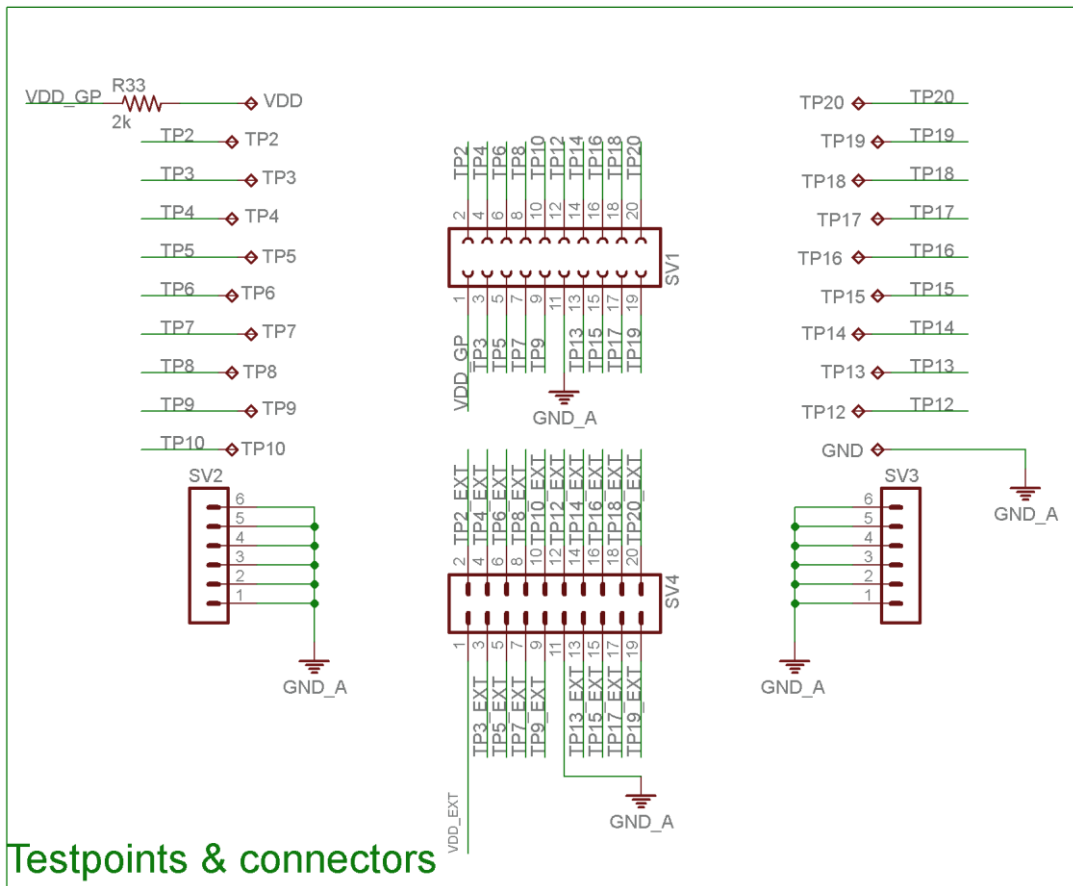

Figure 38: Analog Switches, Protection Diodes and LEDs



Testpoints & connectors

Figure 39: Socket and Expansion Connectors

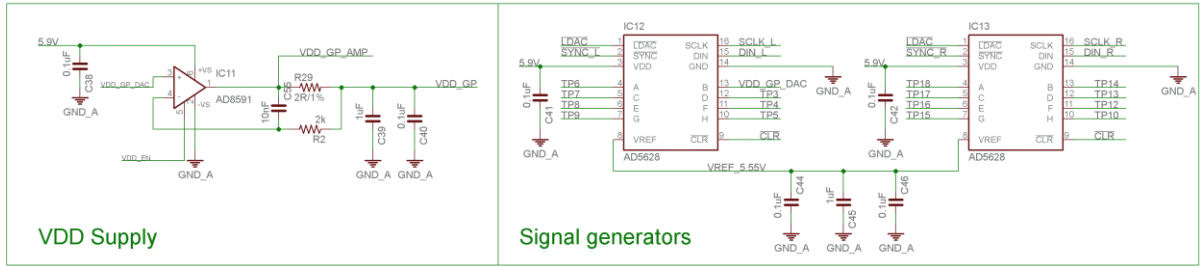

Figure 40: Signal Generator

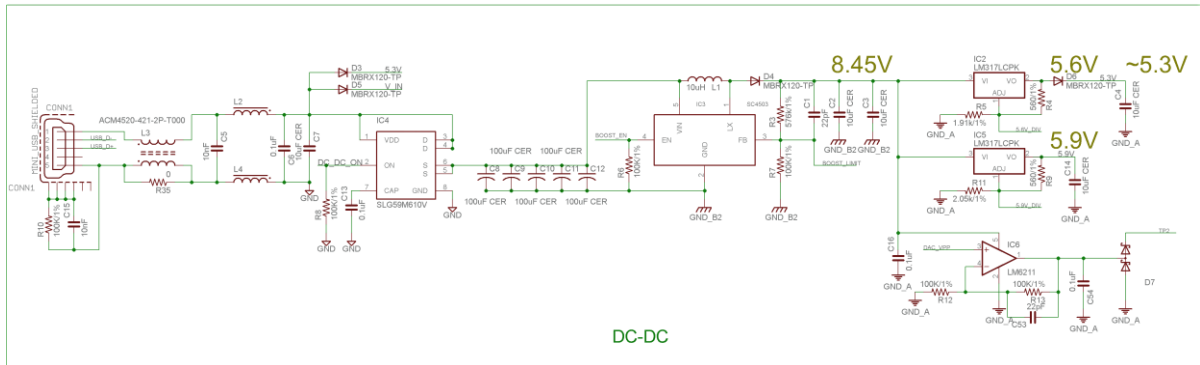

Figure 41: Boost Converter USB Interface

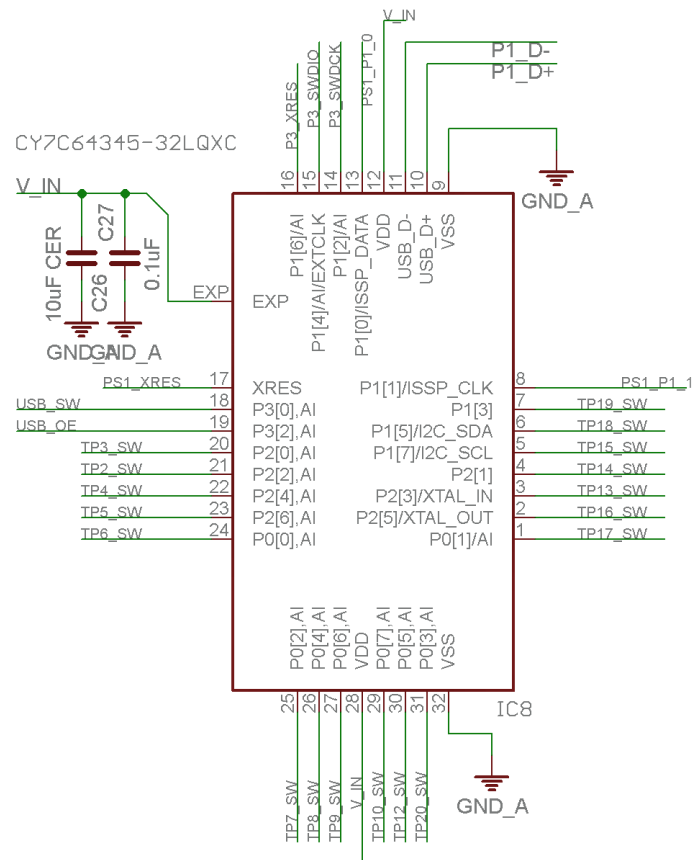

Figure 42: Port Extender

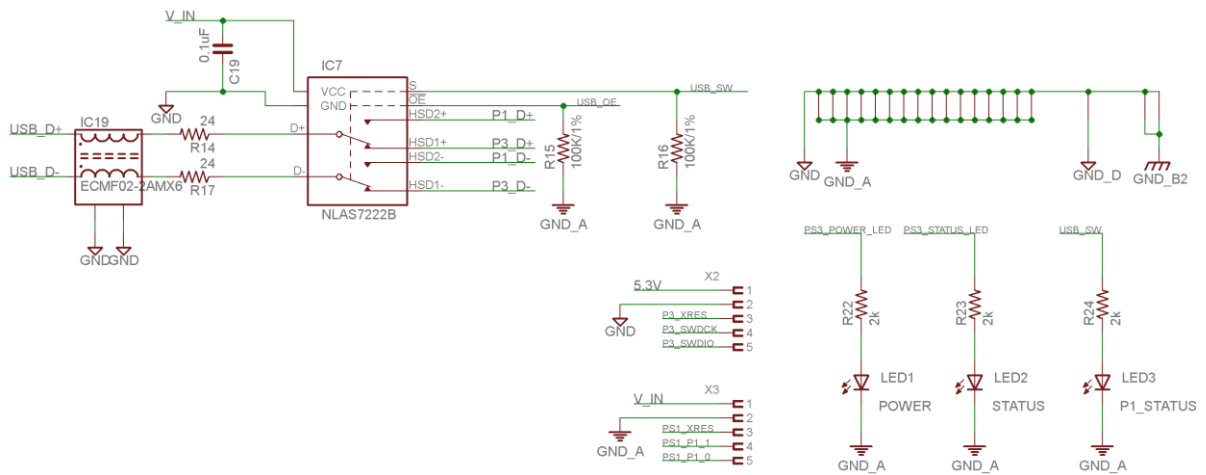

Figure 43: USB Protection

Appendix C BOM

#	Items	Package	Quantity per Development Board	Symbol
1	N/A	TQFN20	1	
2	MCU	TQFN-100	1	IC9
3	CY7C64345-32LQXC	QFN-32	1	IC8
4	AD5628BRUZ-2	16TSSOP	2	IC12, IC13
5	NLAS7222BMUTBG	10-UFQFN	1	IC7
6	MAX4712EUE+	16TSSOP	5	IC14-IC18
7	BAS21SLT1G	SOT-23-3	19	D7-D25
8	GM1JS35200AE	0603 (1608 Metric)	1	LED1
9	LB Q39E-N1P1-35-1	0603 (1608 Metric)	1	LED2
10	LW Q38G-Q1S1-3K6L-1	0603 (1608 Metric)	1	LED3
11	LTST-C193KGKT-5A	0603 (1608 Metric)	17	LED4-LED20
12	NX5032-GA -25.0MHz-LN-CD-1	2-SMD	1	X1
13	SC4503TSKTRT	TSOT23-5	1	IC3
14	USB-M26FTR		1	CONN1
15	2N7002	SOT-23-3	2	Q1, Q2
16	MBRX120-TP	SOD-123	4	D3-D6
17	SLG59M610V	TDFN-8	1	IC4
18	AD8591	SOT-23-6	1	IC11
19	ECMF02 -2AMX6	6-UFQFN	1	IC19
20	NRS4018T100MDGJ	4.00x4.00x1.8mm	1	L1
21	BLM18KG260TN1	0603 (1608 Metric)	2	L2, L4
22	RESISTOR 10k OHM 1/10W 1%	0603 (1608 Metric)	1	R27
23	RESISTOR 44.2k OHM 1/10W 1%	0603 (1608 Metric)	1	R28
24	ACM4520-421-2P- T000	4.70x4.50mm	1	L3
25	GRM31CF50J107ZE0 1L	1206 (3216 Metric)	5	C8-C12
26	LM317LCPK	SOT89-3	2	IC2, IC5
27	LM6211MF/NOPB	SOT23-5	2	IC6, IC10
28	GRM155F51C104ZA0 1D	0402 (1005 Metric)	28	C6, C13, C16, C19, C20, C22, C23, C27, C28, C30, C31, C33, C35, C36, C37, C38, C40, C41, C42, C44, C46, C47, C48, C49, C50, C51, C54, Csoc
29	EMK316BJ106KL-T	1206 (3216 Metric)	7	C2, C3, C4, C7, C14, C26, C32

#	Items	Package	Quantity per Development Board	Symbol
30	C2012X7R1C105K/1.25	0805 (2012 Metric)	4	C21, C29, C39, C45
31	CC0402KRX7R9BB103	0402 (1005 Metric)	4	C5, C15, C52, C55
32	CC0402JRNPO9BN220	0402 (1005 Metric)	8	C1, C17, C18, C24, C25, C34, C43, C53
33	RESISTOR 442k 1/16W 1%	0402 (1005 Metric)	1	R25
34	RESISTOR 100k 1/16W 1%	0402 (1005 Metric)	14	R1, R6, R7, R8, R10, R12, R13, R15, R16, R20, R21, R26, R31, R32
35	RESISTOR 453k 1/16W 1%	0402 (1005 Metric)	3	R18, R19, R30
36	RESISTOR 576k 1/16W 1%	0402 (1005 Metric)	1	R3
37	RESISTOR 560 1/16W 1%	0402 (1005 Metric)	2	R4, R9
38	RESISTOR 2.05 1/16W 1%	0402 (1005 Metric)	1	R11
39	RESISTOR 1.91k 1/16W 1%	0402 (1005 Metric)	1	R5
40	RESISTOR 2k 1/16W	0402 (1005 Metric)	6	R2, R22, R23, R24, R33, R34
41	RESISTOR 24 Ω	0402 (1005 Metric)	2	R14, R17
42	RESISTOR 2 Ω	0805 (2012 Metric)	1	R29
43	YC164-JR-072KL	1206 (3216 Metric)	4	RN6, RN7, RN8, RN9
44	YC164-JR-07100RL	1206 (3216 Metric)	5	RN1, RN2, RN3, RN4, RN5
45	5000_		1	V _{DD}
46	5001_		1	GND
47	5002_		18	TP2-TP10, TP12-TP20
48	SJ61A6		5	
49	TSW-110-08-L-D-RA	0.100" (2.54mm)	2	SV4, SVsoc
50	SSQ-110-02-T-D-RA	0.100" (2.54mm)	1	SV1
51	961106-6404-AR	0.100" (2.54mm)	2	SV2, SV3
52	3021009-06		1	
53	RESISTOR 0 Ω	1206 (3216 Metric)	1	R35
54	SLG55321	TDFN-8	1	IC1
55	BZV55C5V6-TP	SOD-80C	1	D1

Revision History

Revision	Date	Description
2.4	21-Mar-2022	Renesas rebranding
2.3	14-Sep-2021	Added section Generators
2.2	21-Feb-2020	Updated according to Dialog's Writing Guideline

GreenPAK Advanced Development Platform**Status Definitions**

Status	Definition
DRAFT	The content of this document is under review and subject to formal approval, which may result in modifications or additions.
APPROVED or unmarked	The content of this document has been approved for publication.

RoHS Compliance

Renesas Electronics Corporation's suppliers certify that its products are in compliance with the requirements of Directive 2011/65/EU of the European Parliament on the restriction of the use of certain hazardous substances in electrical and electronic equipment. RoHS certificates from our suppliers are available on request.

IMPORTANT NOTICE AND DISCLAIMER

RENESAS ELECTRONICS CORPORATION AND ITS SUBSIDIARIES (“RENESAS”) PROVIDES TECHNICAL SPECIFICATIONS AND RELIABILITY DATA (INCLUDING DATASHEETS), DESIGN RESOURCES (INCLUDING REFERENCE DESIGNS), APPLICATION OR OTHER DESIGN ADVICE, WEB TOOLS, SAFETY INFORMATION, AND OTHER RESOURCES “AS IS” AND WITH ALL FAULTS, AND DISCLAIMS ALL WARRANTIES, EXPRESS OR IMPLIED, INCLUDING, WITHOUT LIMITATION, ANY IMPLIED WARRANTIES OF MERCHANTABILITY, FITNESS FOR A PARTICULAR PURPOSE, OR NON-INFRINGEMENT OF THIRD-PARTY INTELLECTUAL PROPERTY RIGHTS.

These resources are intended for developers who are designing with Renesas products. You are solely responsible for (1) selecting the appropriate products for your application, (2) designing, validating, and testing your application, and (3) ensuring your application meets applicable standards, and any other safety, security, or other requirements. These resources are subject to change without notice. Renesas grants you permission to use these resources only to develop an application that uses Renesas products. Other reproduction or use of these resources is strictly prohibited. No license is granted to any other Renesas intellectual property or to any third-party intellectual property. Renesas disclaims responsibility for, and you will fully indemnify Renesas and its representatives against, any claims, damages, costs, losses, or liabilities arising from your use of these resources. Renesas' products are provided only subject to Renesas' Terms and Conditions of Sale or other applicable terms agreed to in writing. No use of any Renesas resources expands or otherwise alters any applicable warranties or warranty disclaimers for these products.

(Disclaimer Rev.1.01)

Corporate Headquarters

TOYOSU FORESIA, 3-2-24 Toyosu,
Koto-ku, Tokyo 135-0061, Japan
www.renesas.com

Trademarks

Renesas and the Renesas logo are trademarks of Renesas Electronics Corporation. All trademarks and registered trademarks are the property of their respective owners.

Contact Information

For further information on a product, technology, the most up-to-date version of a document, or your nearest sales office, please visit www.renesas.com/contact-us/.

Mouser Electronics

Authorized Distributor

Click to View Pricing, Inventory, Delivery & Lifecycle Information:

[Renesas Electronics:](#)

[SLG46857AP-SKT](#) [SLG47115EV-SKT](#) [SLG46826EV-SKT](#) [SLG46620EV-SKT](#) [SLG46855EV-SKT](#) [SLG47105EV-SKT](#) [SLG47003V-SKT](#) [SLG47001V-SKT](#) [SLG47011V-SKT](#)