

## HS-1840ARH, HS-1840AEH, HS-1840BRH, HS-1840BEH

Rad-Hard 16 Channel BiCMOS Analog Multiplexer with High-Z Analog Input Protection

FN4355  
Rev 6.00  
May 23, 2013

The HS-1840ARH, HS-1840AEH, HS-1840BRH and HS-1840BEH are radiation hardened, monolithic 16 channel multiplexers constructed with the Intersil Rad-Hard Silicon Gate, bonded wafer, Dielectric Isolation process. They are designed to provide a high input impedance to the analog source if device power fails (open), or the analog signal voltage inadvertently exceeds the supply by up to  $\pm 35V$ , regardless of whether the device is powered on or off. Excellent for use in redundant applications, since the secondary device can be operated in a standby unpowered mode affording no additional power drain. More significantly, a very high impedance exists between the active and inactive devices preventing any interaction. One of sixteen channel selections is controlled by a 4-bit binary address plus an Enable-Inhibit input which conveniently controls the ON/OFF operation of several multiplexers in a system. All inputs have electrostatic discharge protection. The HS-1840ARH, HS-1840AEH, HS-1840BRH and HS-1840BEH are processed and screened in full compliance with MIL-PRF-38535 and QML standards. The devices are available in a 28 Ld SBDIP and a 28 Ld Ceramic Flatpack.

Specifications for Rad Hard QML devices are controlled by the Defense Logistics Agency Land and Maritime (DLA). The SMD numbers listed here must be used when ordering.

Detailed Electrical Specifications for these devices are contained in SMD [5962-95630](#).

## Features

- Electrically screened to SMD # [5962-95630](#)
- QML qualified per MIL-PRF-38535 requirements
- Pin-to-pin for Intersil's HS-1840RH and HS-1840/883S
- Improved radiation performance
  - Gamma dose ( $\gamma$ )  $3 \times 10^5 \text{RAD(Si)}$
- Improved  $r_{DS(ON)}$  Linearity
- Improved access time  $1.5\mu\text{s}$  (Max) over temp and post rad
- High analog input impedance  $500M\Omega$  during power loss (open)
- $\pm 35V$  input overvoltage protection (power on or off)
- Dielectrically isolated device islands
- Excellent in Hi-Rel redundant systems
- Break-before-make switching
- No latch-up

## Pin Configuration

HS1-1840ARH, HS1-1840AEH, HS1-1840BRH,  
HS1-1840BEH  
(28 LD SBDIP) CDIP2-T28  
TOP VIEW

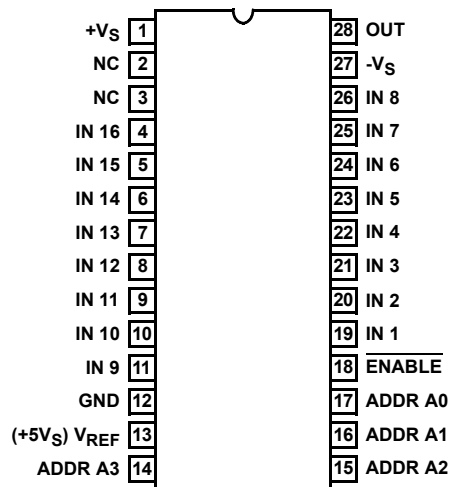

HS9-1840ARH, HS9-1840AEH, HS9-1840BRH, HS9-1840BEH  
(28 LD FLATPACK) CDFP3-F28  
TOP VIEW

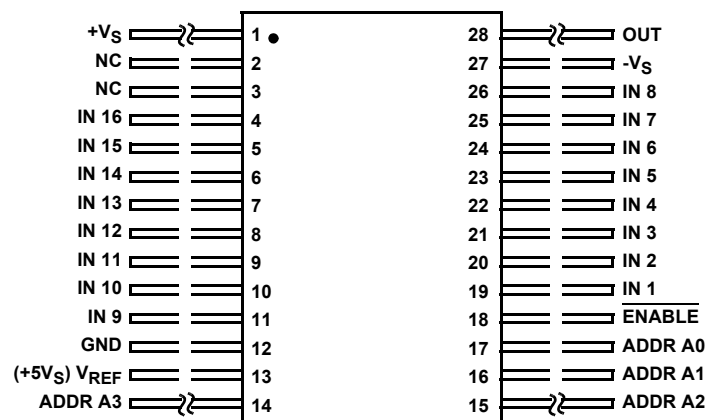

## Ordering Information

ORDERING NUMBER (Note 1)	INTERNAL MKT. NUMBER	PART MARKING NO.	TEMP. RANGE (°C)	PACKAGE (RoHS Compliant)
5962F9563002QXC	HS1-1840ARH-8	Q 5962F95 63002QXC	-55 to +125	28 Ld SBDIP
5962F9563002QYC	HS9-1840ARH-8	Q 5962F95 63002QYC	-55 to +125	28 Ld Flatpack
5962F9563002VXC	HS1-1840ARH-Q	Q 5962F95 63002VXC	-55 to +125	28 Ld SBDIP
5962F9563002VYC	HS9-1840ARH-Q	Q 5962F95 63002VYC	-55 to +125	28 Ld Flatpack
HS0-1840ARH/SAMPLE	HS0-1840ARH/SAMPLE	Die	-55 to +125	
HS1-1840ARH/PROTO	HS1-1840ARH/PROTO	HS1- 1840ARH /PROTO	-55 to +125	28 Ld SBDIP
HS9-1840ARH/PROTO	HS9-1840ARH/PROTO	HS9- 1840ARH /PROTO	-55 to +125	28 Ld Flatpack
5962R9563002TXC	HS1-1840ARH-T	Q 5962R95 63002TXC	-55 to +125	28 Ld SBDIP
5962F9563002V9A	HS0-1840ARH-Q	Die	-55 to +125	
5962F9563004V9A	HS0-1840AEH-Q	Die	-55 to +125	
5962F9563004VXC	HS1-1840AEH-Q	Q 5962F95 63004VXC	-55 to +125	28 Ld SBDIP
5962F9563004VYC	HS9-1840AEH-Q	Q 5962F95 63004VYC	-55 to +125	28 Ld Flatpack
5962F9563005V9A	HS0-1840BEH-Q	Die	-55 to +125	
5962F9563005VXC	HS1-1840BEH-Q	Q 5962F95 63005VXC	-55 to +125	28 Ld SBDIP
5962F9563005VYC	HS9-1840BEH-Q	Q 5962F95 63005VYC	-55 to +125	28 Ld Flatpack
5962F9563003QXC	HS1-1840BRH-8	Q 5962F95 63003QXC	-55 to +125	28 Ld SBDIP
5962F9563003QYC	HS9-1840BRH-8	Q 5962F95 63003QYC	-55 to +125	28 Ld Flatpack
5962F9563003VXC	HS1-1840BRH-Q	Q 5962F95 63003VXC	-55 to +125	28 Ld SBDIP
5962F9563003VYC	HS9-1840BRH-Q	Q 5962F95 63003VYC	-55 to +125	28 Ld Flatpack
HS1-1840BRH/PROTO	HS1-1840BRH/PROTO	HS1- 1840BRH /PROTO	-55 to +125	28 Ld SBDIP
HS9-1840BRH/PROTO	HS9-1840BRH/PROTO	HS9- 1840BRH /PROTO	-55 to +125	28 Ld Flatpack
5962F9563003V9A	HS0-1840BRH-Q	Die	-55 to +125	
HS0-1840BRH/SAMPLE	HS0-1840BRH/SAMPLE	Die	-55 to +125	
5962F9563002VZC	HS9G-1840ARH-Q (Note 2)	Q 5962F95 63002VZC	-55 to +125	28 Ld Flatpack
HS9G-1840ARH/PROTO	HS9G-1840ARH/PROTO (Note 2)	HS9G-1840ARH/PROTO	-55 to +125	28 Ld Flatpack

### NOTES:

1. These Intersil Pb-free Hermetic packaged products employ 100% Au plate - e4 termination finish, which is RoHS compliant and compatible with both SnPb and Pb-free soldering operations.
2. The lid of these packages are connected to the ground pin of the device.

## Functional Diagram

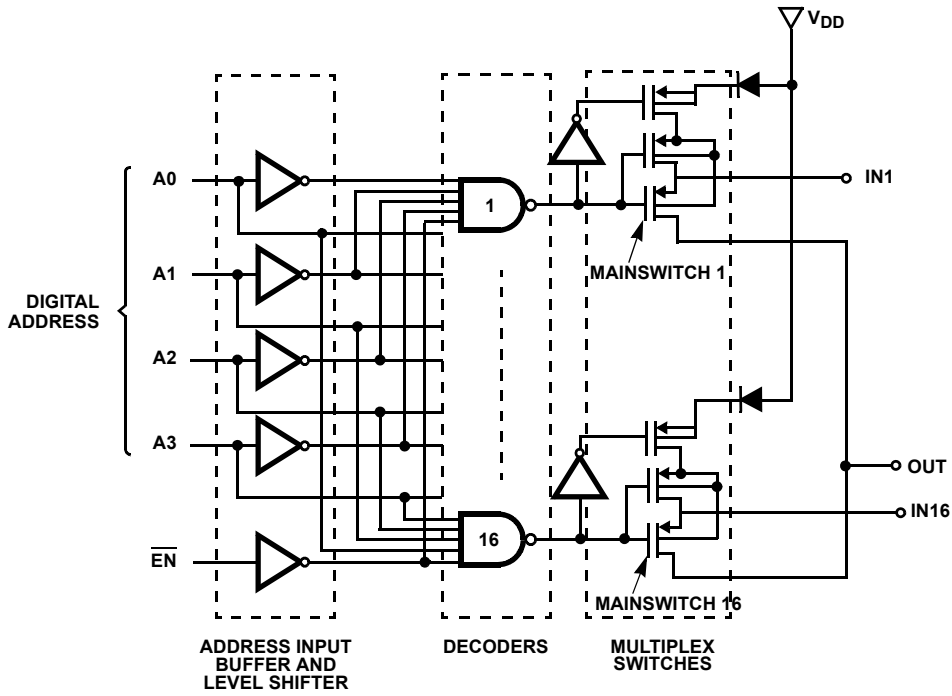

NOTE: MAINSWITCH INXX: SWITCH ON, BODY TIED TO SOURCE  
SWITCH OFF, BODY TIED TO VCC-0.7V

TABLE 1. TRUTH TABLE

A3	A2	A1	A0	$\overline{EN}$	"ON" CHANNEL
X	X	X	X	H	None
L	L	L	L	L	1
L	L	L	H	L	2
L	L	H	L	L	3
L	L	H	H	L	4
L	H	L	L	L	5
L	H	L	H	L	6
L	H	H	L	L	7
L	H	H	H	L	8
H	L	L	L	L	9
H	L	L	H	L	10
H	L	H	L	L	11
H	L	H	H	L	12
H	H	L	L	L	13
H	H	L	H	L	14
H	H	H	L	L	15
H	H	H	H	L	16

## Burn-In/Life Test Circuits

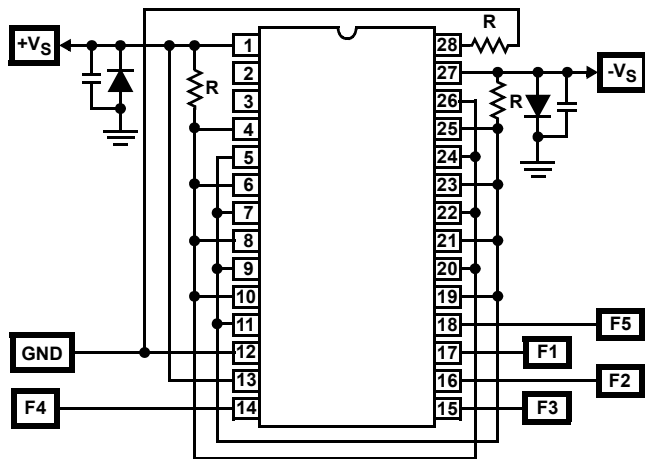

NOTE:  
 $V_{S+} = +15.5V \pm 0.5V$ ,  $V_{S-} = -15.5V \pm 0.5V$ .  
 $R = 1k\Omega \pm 5\%$ .  
 $C_1 = C_2 = 0.01\mu F \pm 10\%$ , 1 EACH PER SOCKET, MINIMUM.  
 $D_1 = D_2 = 1N4002$ , 1 EACH PER BOARD, MINIMUM.  
 INPUT SIGNALS:  
 SQUARE WAVE, 50% DUTY CYCLE, 0V TO 15V PEAK  $\pm 10\%$ .  
 $F_1 = 100kHz$ ;  $F_2 = F_1/2$ ;  $F_3 = F_1/4$ ;  $F_4 = F_1/8$ ;  $F_5 = F_1/16$ .

FIGURE 1. DYNAMIC BURN-IN AND LIFE TEST CIRCUIT

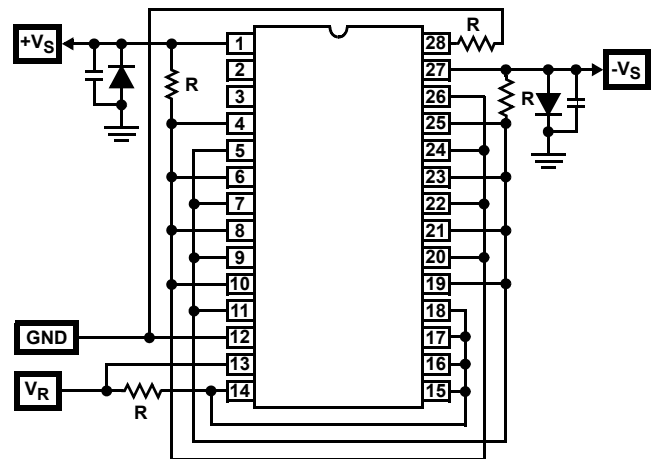

NOTE:  
 $R = 1k\Omega \pm 5\%$ , 1/4W.  
 $C_1 = C_2 = 0.01\mu F$  MINIMUM, 1 EACH PER SOCKET, MINIMUM.  
 $V_{S+} = 15.5V \pm 0.5V$ ,  $V_{S-} = -15.5V \pm 0.5V$ ,  $V_R = 15.5 \pm 0.5V$

FIGURE 2. STATIC BURN-IN TEST CIRCUIT

NOTES:

1. The above test circuits are utilized for all package types.
2. The Dynamic Test Circuit is utilized for all life testing.

## Irradiation Circuit

HS-1840ARH, HS-1840AEH, HS-1840BRH, HS-1840BEH

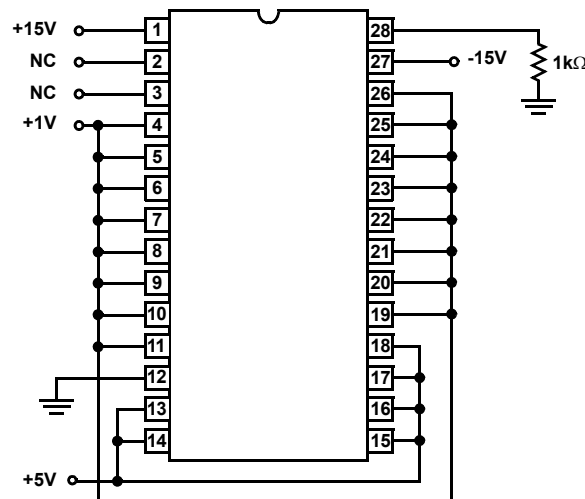

NOTE:

3. All irradiation testing is performed in the 28 lead CERDIP package.

## Die Characteristics

### DIE DIMENSIONS:

(2820 $\mu\text{m}$ x4080 $\mu\text{m}$  x 483 $\mu\text{m}$   $\pm$ 25.4 $\mu\text{m}$ )  
111 mils x 161 mils x 19 mils  $\pm$ 1 mil

### INTERFACE MATERIALS:

#### Glassivation:

Type: PSG (Phosphorus Silicon Glass)  
Thickness: 8.0k $\text{\AA}$   $\pm$ 1k $\text{\AA}$

#### Top Metallization:

Type: AlSiCu  
Thickness: 16.0k $\text{\AA}$   $\pm$ 2k $\text{\AA}$

#### Backside Finish:

Silicon

### ASSEMBLY RELATED INFORMATION:

#### Substrate Potential:

Unbiased (DI)

### ADDITIONAL INFORMATION:

#### Worst Case Current Density:

Modified SEM

#### Transistor Count:

407

#### Process:

Radiation Hardened Silicon Gate,  
DI Wafer, Dielectric Isolation

## Metallization Mask Layout

HS-1840ARH, HS-1840BRH

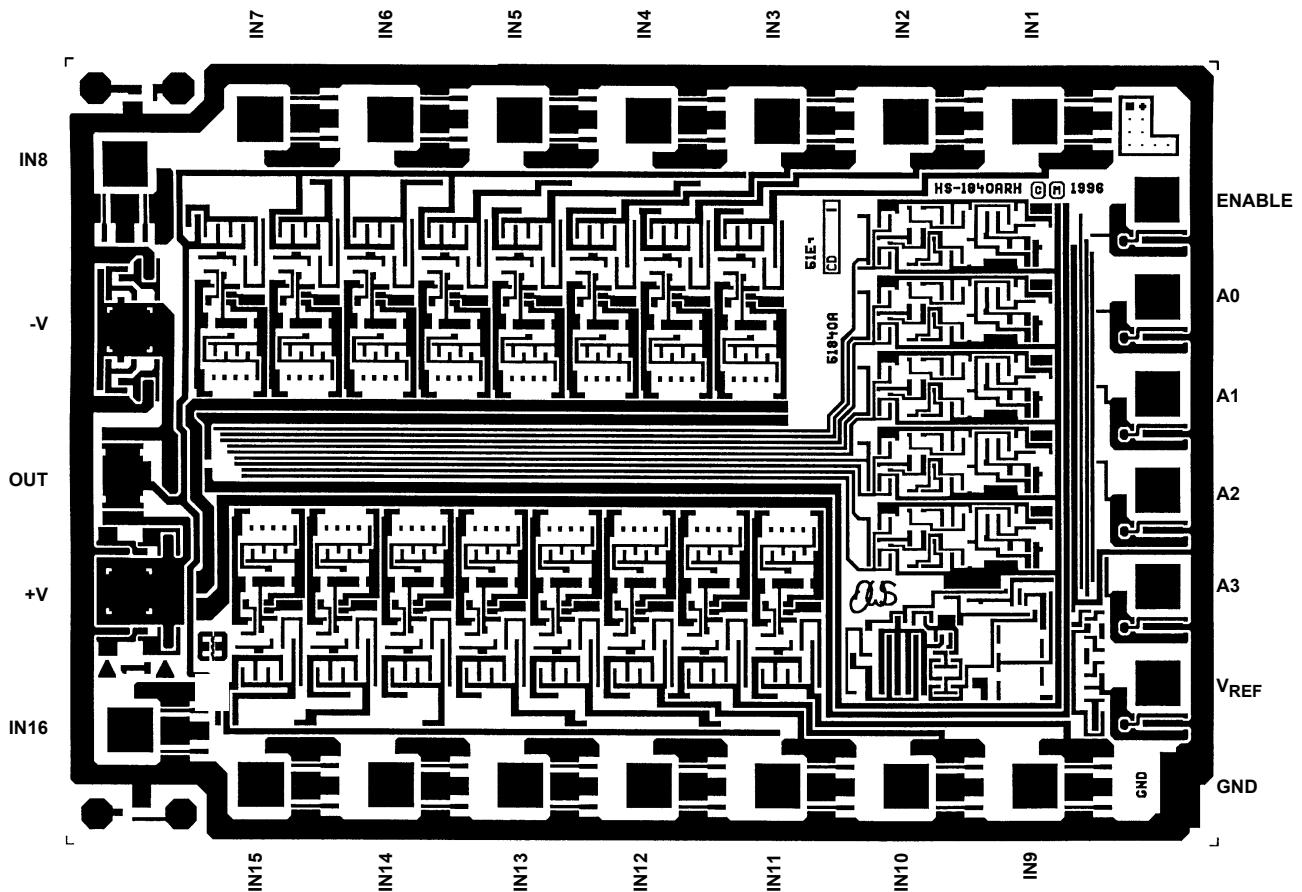

**Ceramic Dual-In-Line Metal Seal Packages (SBDIP)**

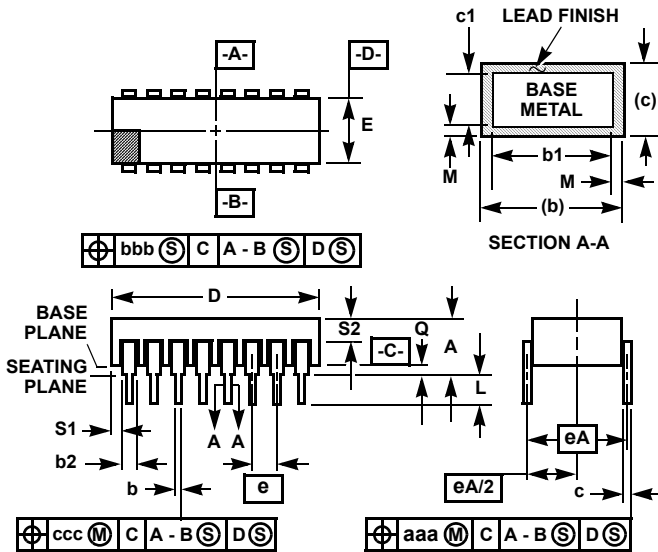

**D28.6 MIL-STD-1835 CDIP2-T28 (D-10, CONFIGURATION C)  
28 LEAD CERAMIC DUAL-IN-LINE METAL SEAL PACKAGE**

SYMBOL	INCHES		MILLIMETERS		NOTES
	MIN	MAX	MIN	MAX	
A	-	0.232	-	5.92	-
b	0.014	0.026	0.36	0.66	2
b1	0.014	0.023	0.36	0.58	3
b2	0.045	0.065	1.14	1.65	-
b3	0.023	0.045	0.58	1.14	4
c	0.008	0.018	0.20	0.46	2
c1	0.008	0.015	0.20	0.38	3
D	-	1.490	-	37.85	-
E	0.500	0.610	12.70	15.49	-
e	0.100 BSC		2.54 BSC		-
eA	0.600 BSC		15.24 BSC		-
eA/2	0.300 BSC		7.62 BSC		-
L	0.125	0.200	3.18	5.08	-
Q	0.015	0.060	0.38	1.52	5
S1	0.005	-	0.13	-	6
S2	0.005	-	0.13	-	7
$\alpha$	90°	105°	90°	105°	-
aaa	-	0.015	-	0.38	-
bbb	-	0.030	-	0.76	-
ccc	-	0.010	-	0.25	-
M	-	0.0015	-	0.038	2
N	28		28		8

**NOTES:**

1. Index area: A notch or a pin one identification mark shall be located adjacent to pin one and shall be located within the shaded area shown. The manufacturer's identification shall not be used as a pin one identification mark.
2. The maximum limits of lead dimensions b and c or M shall be measured at the centroid of the finished lead surfaces, when solder dip or tin plate lead finish is applied.
3. Dimensions b1 and c1 apply to lead base metal only. Dimension M applies to lead plating and finish thickness.
4. Corner leads (1, N, N/2, and N/2+1) may be configured with a partial lead paddle. For this configuration dimension b3 replaces dimension b2.
5. Dimension Q shall be measured from the seating plane to the base plane.
6. Measure dimension S1 at all four corners.
7. Measure dimension S2 from the top of the ceramic body to the nearest metallization or lead.
8. N is the maximum number of terminal positions.
9. Braze fillets shall be concave.
10. Dimensioning and tolerancing per ANSI Y14.5M - 1982.
11. Controlling dimension: INCH.

Rev. 0 5/18/94

© Copyright Intersil Americas LLC 2002-2013. All Rights Reserved.  
All trademarks and registered trademarks are the property of their respective owners.

For additional products, see [www.intersil.com/en/products.html](http://www.intersil.com/en/products.html)

Intersil products are manufactured, assembled and tested utilizing ISO9001 quality systems as noted in the quality certifications found at [www.intersil.com/en/support/qualandreliability.html](http://www.intersil.com/en/support/qualandreliability.html)

*Intersil products are sold by description only. Intersil may modify the circuit design and/or specifications of products at any time without notice, provided that such modification does not, in Intersil's sole judgment, affect the form, fit or function of the product. Accordingly, the reader is cautioned to verify that datasheets are current before placing orders. Information furnished by Intersil is believed to be accurate and reliable. However, no responsibility is assumed by Intersil or its subsidiaries for its use; nor for any infringements of patents or other rights of third parties which may result from its use. No license is granted by implication or otherwise under any patent or patent rights of Intersil or its subsidiaries.*

For information regarding Intersil Corporation and its products, see [www.intersil.com](http://www.intersil.com)

**Ceramic Metal Seal Flatpack Packages (Flatpack)**

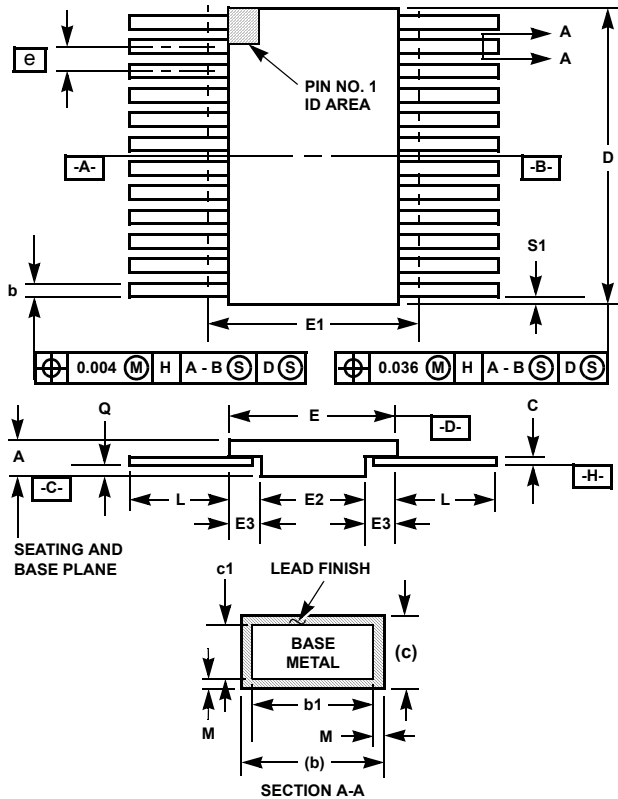

**K28.A MIL-STD-1835 CDFP3-F28 (F-11A, CONFIGURATION B)  
28 LEAD CERAMIC METAL SEAL FLATPACK PACKAGE**

SYMBOL	INCHES		MILLIMETERS		NOTES
	MIN	MAX	MIN	MAX	
A	0.045	0.115	1.14	2.92	-
b	0.015	0.022	0.38	0.56	-
b1	0.015	0.019	0.38	0.48	-
c	0.004	0.009	0.10	0.23	-
c1	0.004	0.006	0.10	0.15	-
D	-	0.740	-	18.80	3
E	0.460	0.520	11.68	13.21	-
E1	-	0.550	-	13.97	3
E2	0.180	-	4.57	-	-
E3	0.030	-	0.76	-	7
e	0.050 BSC		1.27 BSC		-
k	0.008	0.015	0.20	0.38	2
L	0.250	0.370	6.35	9.40	-
Q	0.026	0.045	0.66	1.14	8
S1	0.00	-	0.00	-	6
M	-	0.0015	-	0.04	-
N	28		28		-

Rev. 0 5/18/94

**NOTES:**

1. Index area: A notch or a pin one identification mark shall be located adjacent to pin one and shall be located within the shaded area shown. The manufacturer's identification shall not be used as a pin one identification mark. Alternately, a tab (dimension k) may be used to identify pin one.
2. If a pin one identification mark is used in addition to a tab, the limits of dimension k do not apply.
3. This dimension allows for off-center lid, meniscus, and glass overrun.
4. Dimensions b1 and c1 apply to lead base metal only. Dimension M applies to lead plating and finish thickness. The maximum limits of lead dimensions b and c or M shall be measured at the centroid of the finished lead surfaces, when solder dip or tin plate lead finish is applied.
5. N is the maximum number of terminal positions.
6. Measure dimension S1 at all four corners.
7. For bottom-brazed lead packages, no organic or polymeric materials shall be molded to the bottom of the package to cover the leads.
8. Dimension Q shall be measured at the point of exit (beyond the meniscus) of the lead from the body. Dimension Q minimum shall be reduced by 0.0015 inch (0.038mm) maximum when solder dip lead finish is applied.
9. Dimensioning and tolerancing per ANSI Y14.5M - 1982.
10. Controlling dimension: INCH.

# Mouser Electronics

Authorized Distributor

Click to View Pricing, Inventory, Delivery & Lifecycle Information:

[Renesas Electronics:](#)

[HS1-1840AEH-Q](#) [HS9-1840AEH-Q](#)