

TMC2041 DATASHEET

Dual step/direction driver for up to two 2-phase bipolar stepper motors. stallGuard for sensorless homing. SPI, UART (single wire) Configuration and Diagnostics Interface.

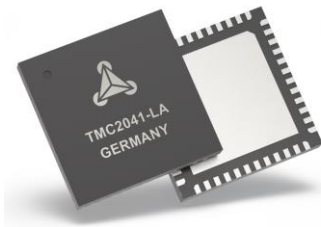

coolStep™

stallGuard2™

APPLICATIONS

Office Automation
Antenna Positioning
3D printers
Battery powered applications
Printer and Scanner
Pumps and Valves
Medical Applications
Office and Laboratory equipment

FEATURES AND BENEFITS

Two 2-phase stepper motors
Drive Capability up to 2x 1.1A coil current (2x 1.5A peak)
Parallel Option for one motor at 2.2A (3A peak)
Voltage Range 4.75... 26V DC
SPI & Single Wire UART for configuration and diagnostics
Highest Resolution up to 256 microsteps per full step
microPlyer™ microstep interpolation
spreadCycle™ highly dynamic motor control chopper
stallGuard2™ high precision sensorless motor load detection
coolStep™ current control for energy savings up to 75%
Full Protection & Diagnostics
Compact Size 7x7mm² QFN48 package

DESCRIPTION

The TMC2041 is a compact, dual stepper motor driver IC with serial interfaces for configuration and diagnostics. It is pin compatible to the fully featured TMC5041 and TMC5072 drivers with internal motion controller. The TMC2041 is intended for all applications, where an internal motion controller is not desired, and ramping is done in a microcontroller. Based on TRINAMIC's high-performance spreadCycle chopper, the driver allows precise and smooth motor operation. It offers coolStep for energy savings and stallGuard for sensorless stall detection. The complete set of protection and diagnostic functionality ensures reliable operation. High integration, high energy efficiency and a small form factor enable miniaturized and scalable systems for cost effective solutions.

BLOCK DIAGRAM

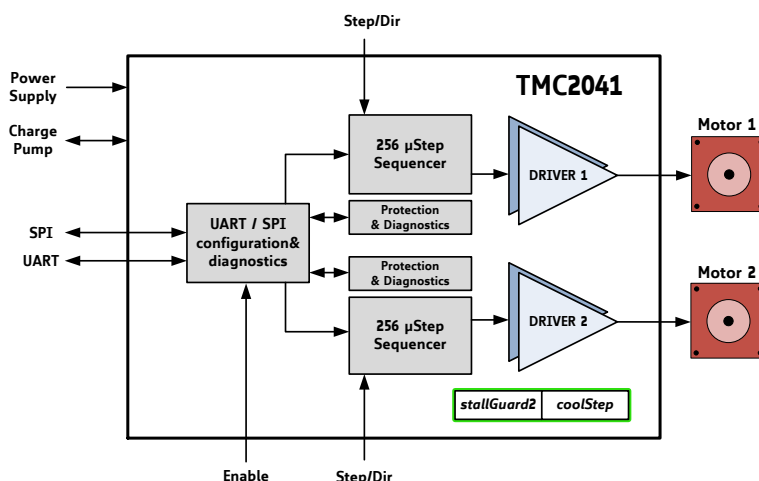

APPLICATION EXAMPLES: HIGH FLEXIBILITY – MULTIPURPOSE USE

The TMC2041 scores with power density and sensorless homing. It features serial interfaces for advanced monitoring and configuration options. The small form factor keeps costs down and allows for miniaturized layouts. Extensive support at the chip, board, and software levels enables rapid design cycles and fast time-to-market with competitive products. High energy efficiency and reliability deliver cost savings in related systems such as power supplies and cooling.

STEP/DIR FOR UP TO TWO STEPPER MOTORS

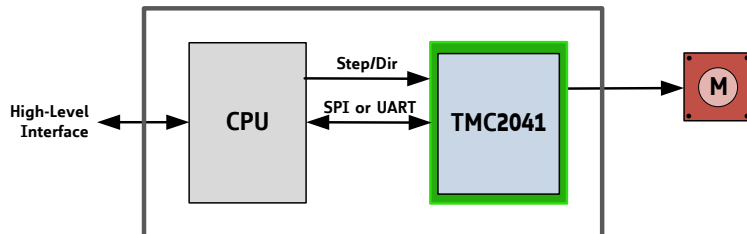

The stepper motor driver outputs are switched in parallel. This way, up to 2.2A RMS motors can be driven.

STEP/DIR FOR UP TO TWO STEPPER MOTORS

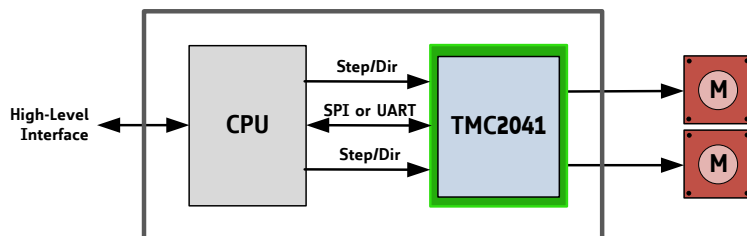

In this application, a single CPU controls two motors using a Step and Direction interface per motor. It initially configures the drivers by programming current settings and chopper, and run and hold current using either the 4 wire SPI interface, or the single wire UART interface. During operation the interface allows access to status information like stallGuard sensorless load measurement.

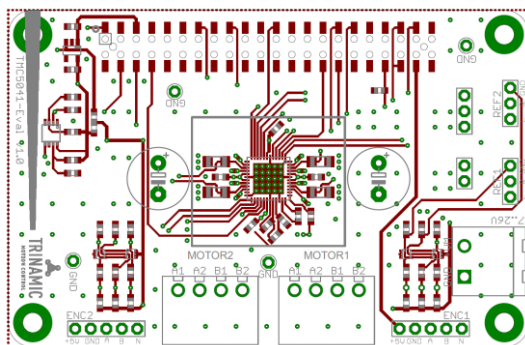

TMC2041-EVAL EVALUATION BOARD EVALUATION & DEVELOPMENT PLATFORM

The TMC2041-EVAL is part of TRINAMICs universal evaluation board system which provides a convenient handling of the hardware as well as a user-friendly software tool for evaluation. The TMC2041 evaluation board system consists of three parts: STARTRAMPE (base board), ESELSBRÜCKE (connector board including several test points), and TMC2041-EVAL.

ORDER CODES

Order code	Description	Size [mm ²]
TMC2041-LA	Dual axis step/dir driver, QFN-48	7 x 7
TMC2041-EVAL	Evaluation board for TMC2041	85 x 55
STARTRAMPE	Baseboard for TMC2041-EVAL and further evaluation boards	85 x 55
ESELSBRÜCKE	Connector board for plug-in evaluation board system	61 x 38

TABLE OF CONTENTS

1	PRINCIPLES OF OPERATION	4			
1.1	KEY CONCEPTS	4			
1.2	CONTROL INTERFACES	4			
1.3	MOVING AND CONTROLLING THE MOTOR	5			
1.4	STALLGUARD2 – MECHANICAL LOAD SENSING	5			
1.5	COOLSTEP – LOAD ADAPTIVE CURRENT CONTROL	5			
2	PIN ASSIGNMENTS	7			
2.1	PACKAGE OUTLINE	7			
2.2	SIGNAL DESCRIPTIONS	7			
3	SAMPLE CIRCUITS	10			
3.1	STANDARD APPLICATION CIRCUIT	10			
3.2	5 V ONLY SUPPLY	11			
3.3	ONE MOTOR WITH HIGH CURRENT	12			
3.4	EXTERNAL 5V POWER SUPPLY	12			
3.5	OPTIMIZING ANALOG PRECISION	13			
3.6	DRIVER PROTECTION AND EME CIRCUITRY	13			
4	SPI INTERFACE	15			
4.1	SPI DATAGRAM STRUCTURE	15			
4.2	SPI SIGNALS	16			
4.3	TIMING	17			
5	UART SINGLE WIRE INTERFACE	18			
5.1	DATAGRAM STRUCTURE	18			
5.2	CRC CALCULATION	20			
5.3	UART SIGNALS	20			
5.4	ADDRESSING MULTIPLE SLAVES	21			
6	REGISTER MAPPING	23			
6.1	GENERAL CONFIGURATION REGISTERS	24			
6.2	CURRENT SETTING	26			
6.3	MOTOR DRIVER REGISTERS	27			
7	CURRENT SETTING	32			
7.1	SENSE RESISTORS	33			
8	SPREADCYCLE AND CLASSIC CHOPPER	34			
8.1	SPREADCYCLE CHOPPER	35			
8.2	CLASSIC CONSTANT OFF TIME CHOPPER	38			
8.3	RANDOM OFF TIME	39			
9	DRIVER DIAGNOSTIC FLAGS	40			
9.1	TEMPERATURE MEASUREMENT	40			
9.2	SHORT TO GND PROTECTION	40			
9.3	OPEN LOAD DIAGNOSTICS	40			
10	STALLGUARD2 LOAD MEASUREMENT	41			
10.1	TUNING STALLGUARD2 THRESHOLD SGT	42			
10.2	STALLGUARD2 UPDATE RATE AND FILTER	44			
10.3	DETECTING A MOTOR STALL	44			
10.4	HOMING WITH STALLGUARD	44			
10.5	LIMITS OF STALLGUARD2 OPERATION	44			
11	COOLSTEP OPERATION	45			
11.1	USER BENEFITS	45			
11.2	SETTING UP FOR COOLSTEP	45			
11.3	TUNING COOLSTEP	47			
12	STEP/DIR INTERFACE	48			
12.1	TIMING	48			
12.2	CHANGING RESOLUTION	49			
12.3	MICROPLYER STEP INTERPOLATOR AND STAND STILL DETECTION	49			
13	QUICK CONFIGURATION GUIDE	51			
14	GETTING STARTED	53			
14.1	INITIALIZATION EXAMPLES	53			
15	EXTERNAL RESET	54			
16	CLOCK OSCILLATOR AND CLOCK INPUT	54			
16.1	USING THE INTERNAL CLOCK	54			
16.2	USING AN EXTERNAL CLOCK	54			
16.3	CONSIDERATIONS ON THE FREQUENCY	54			
17	ABSOLUTE MAXIMUM RATINGS	55			
18	ELECTRICAL CHARACTERISTICS	55			
18.1	OPERATIONAL RANGE	55			
18.2	DC CHARACTERISTICS AND TIMING CHARACTERISTICS	56			
18.3	THERMAL CHARACTERISTICS	59			
19	LAYOUT CONSIDERATIONS	60			
19.1	EXPOSED DIE PAD	60			
19.2	WIRING GND	60			
19.3	SUPPLY FILTERING	60			
19.4	SINGLE DRIVER CONNECTION	60			
19.5	LAYOUT EXAMPLE	61			
20	PACKAGE MECHANICAL DATA	62			
20.1	DIMENSIONAL DRAWINGS	62			
20.2	PACKAGE CODES	62			
21	DISCLAIMER	63			
22	ESD SENSITIVE DEVICE	63			
23	TABLE OF FIGURES	64			
24	REVISION HISTORY	65			
25	REFERENCES	65			

1 Principles of Operation

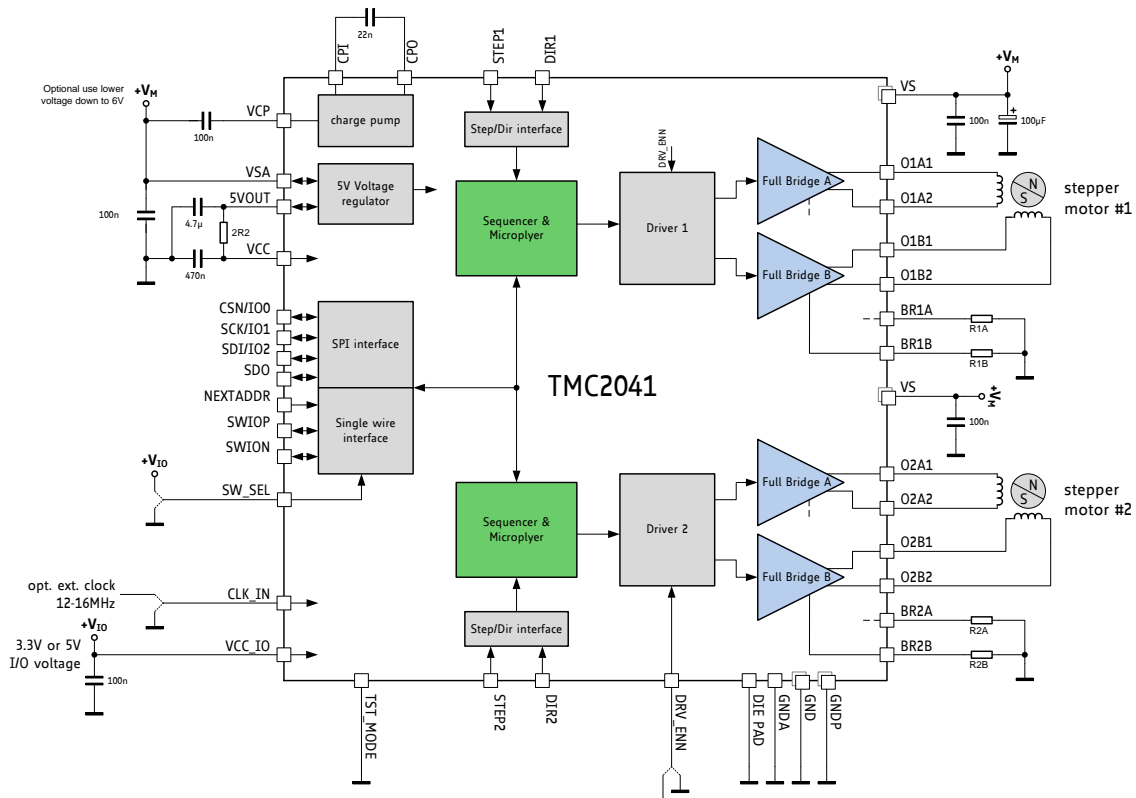

Figure 1.1 Basic application and block diagram

The TMC2041 driver chip is a highly integrated step & direction stepper driver for two stepper motors. The driver, chopper logic, and a 256 microstep sequencer are integrated into the TMC2041. It is pin compatible to the TMC5041 and TMC5072, which provide internal ramping. The TMC2041 offers a number of unique enhancements over similar products. It features automatic standstill current reduction and coolStep for enhanced motor efficiency and provides stallGuard2 for sensorless homing.

1.1 Key Concepts

The TMC2041 implements several advanced features which are exclusive to TRINAMIC products. These features contribute toward greater precision, greater energy efficiency, higher reliability, smoother motion, and cooler operation in many stepper motor applications.

- spreadCycle™** High-precision chopper algorithm available as an alternative to the traditional constant off-time algorithm.
- stallGuard2™** High-precision load measurement using the back EMF on the motor coils.
- coolStep™** Load-adaptive current control which reduces energy consumption by as much as 75%.

In addition to these performance enhancements, TRINAMIC motor drivers offer safeguards to detect and protect against shorted outputs, output open-circuit, overtemperature, and undervoltage conditions for enhancing safety and recovery from equipment malfunctions.

1.2 Control Interfaces

The TMC2041 supports both, an SPI and a UART based single wire interface with CRC checking. Selection of the actual interface is done via the configuration pin SW_SEL, which can be hardwired to GND or VCC_IO depending on the desired interface. From a software point of view the TMC2041 is a peripheral with a number of control and status registers. Most of them can either be written only or

read only. Some of the registers allow both read and write access. In case read-modify-write access is desired for a write only register, a shadow register can be realized in master software.

1.2.1 SPI Interface

The SPI interface is a bit-serial interface synchronous to a bus clock. For every bit sent from the bus master to the bus slave another bit is sent simultaneously from the slave to the master. Communication between an SPI master and the TMC2041 slave always consists of sending one 40-bit command word and receiving one 40-bit status word.

The SPI command rate typically is a few commands per complete motor motion.

1.2.2 UART Interface

The single wire interface allows differential operation similar to RS485 (using SWIOP and SWION) or single wire interfacing (leaving open SWION). It can be driven by any standard UART. No baud rate configuration is required. An optional ring mode allows chaining of slaves to optimize interfacing for applications with regularly distributed drives.

1.3 Moving and Controlling the Motor

1.3.1 STEP/DIR Interface

Each motor is controlled by a step and direction input. Active edges on the STEP input can be rising edges or both rising and falling edges as controlled by another mode bit (DEDGE). Using both edges cuts the toggle rate of the STEP signal in half, which is useful for communication over slow interfaces such as optically isolated interfaces. On each active edge, the state sampled from the DIR input determines whether to step forward or back. Each step can be a fullstep or a microstep, in which there are 2, 4, 8, 16, 32, 64, 128, or 256 microsteps per fullstep. During microstepping, a step impulse with a low state on DIR increases the microstep counter and a high decreases the counter by an amount controlled by the microstep resolution. An internal table translates the counter value into the sine and cosine values which control the motor current for microstepping.

1.4 stallGuard2 – Mechanical Load Sensing

stallGuard2 provides an accurate measurement of the load on the motor. It can be used for stall detection as well as other uses at loads below those which stall the motor, such as coolStep load-adaptive current reduction. This gives more information on the drive allowing functions like sensorless homing and diagnostics of the drive mechanics.

1.5 coolStep – Load Adaptive Current Control

coolStep drives the motor at the optimum current. It uses the stallGuard2 load measurement information to adjust the motor current to the minimum amount required in the actual load situation. This saves energy and keeps the components cool.

Benefits are:

- *Energy efficiency* power consumption decreased up to 75%
- *Motor generates less heat* improved mechanical precision
- *Less or no cooling* improved reliability
- *Use of smaller motor* less torque reserve required → cheaper motor does the job

Figure 1.2 shows the efficiency gain of a 42mm stepper motor when using coolStep compared to standard operation with 50% of torque reserve. coolStep is enabled above 60RPM in the example.

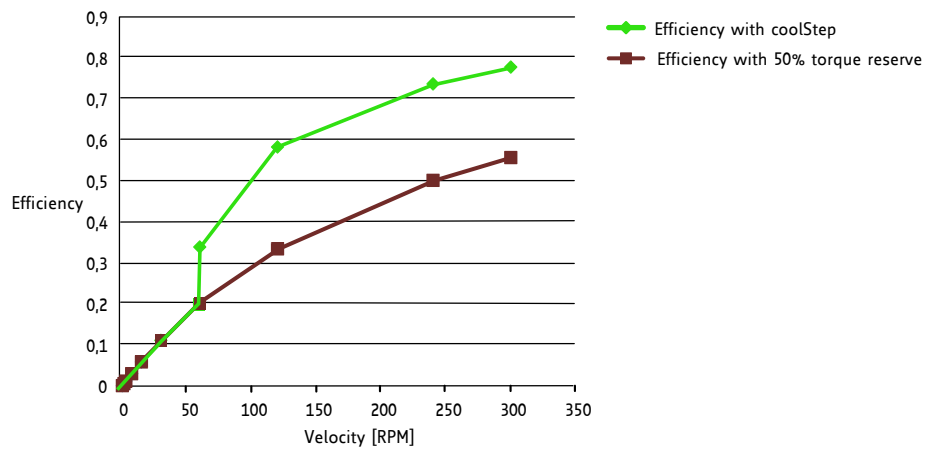

Figure 1.2 Energy efficiency with coolStep (example)

2 Pin Assignments

2.1 Package Outline

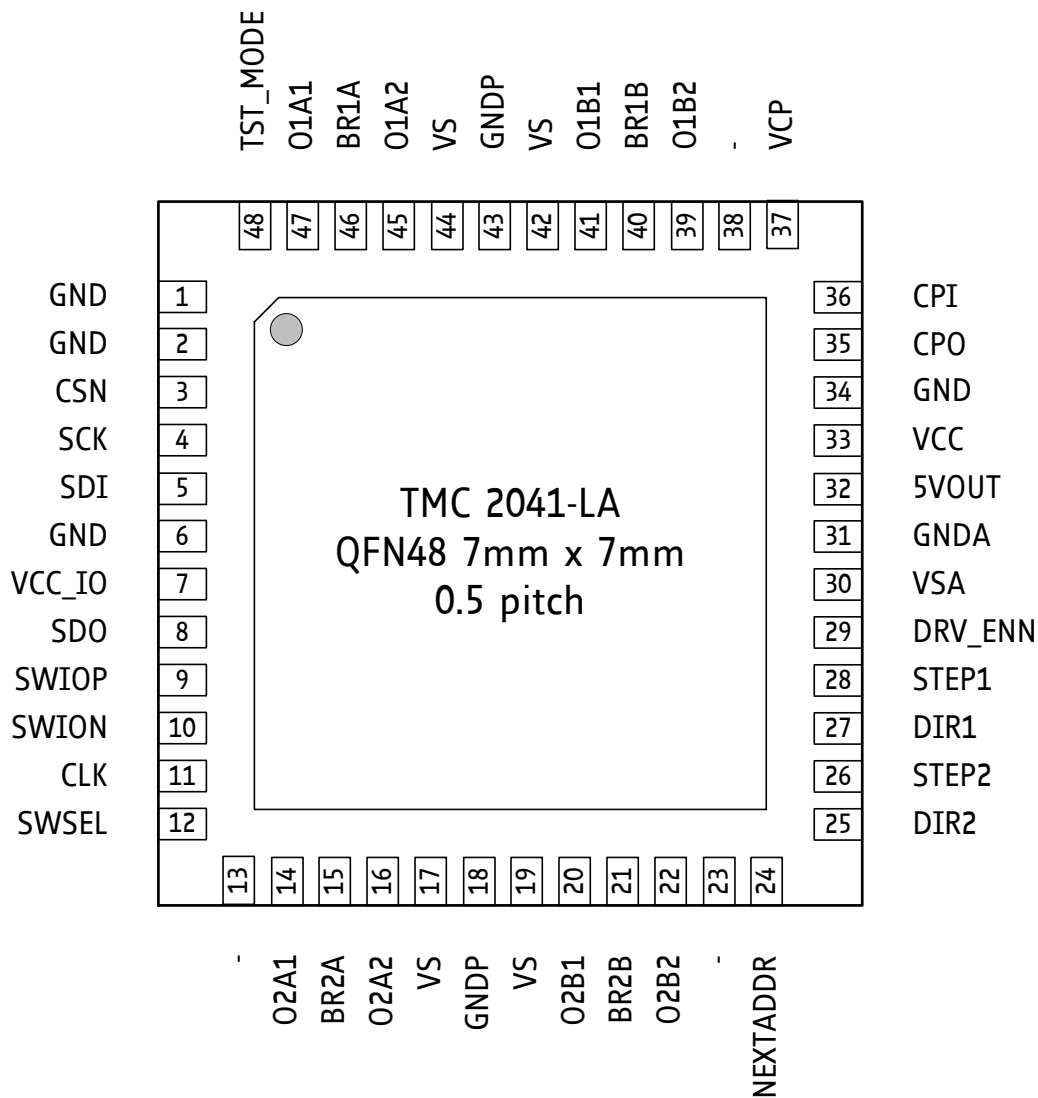

Figure 2.1 TMC2041 pin assignments.

2.2 Signal Descriptions

Pin	Number	Type	Function
GND	6, 34	GND	Digital ground pin for IO pins and digital circuitry.
VCC_IO	7		3.3V or 5V I/O supply voltage pin for all digital pins.
VSA	30		Analog supply voltage for 5V regulator – typically supplied with driver supply voltage. An additional 100nF capacitor to GND (GND plane) is recommended for best performance.
GNDA	31	GND	Analog GND. Tie to GND plane.
5VOUT	32		Output of internal 5V regulator. Attach 2.2µF or larger ceramic capacitor to GNDA near to pin for best performance. Use to supply VCC of chip.

Pin	Number	Type	Function
VCC	33		5V supply input for digital circuitry within chip and charge pump. Attach 470nF capacitor to GND (GND plane). Typically supplied by 5VOUT. A 2.2Ω resistor is recommended for decoupling noise from 5VOUT. When using an external supply, make sure, that VCC comes up before or in parallel to 5VOUT or VCC_IO, whichever comes up later!
DIE_PAD	-	GND	Connect the exposed die pad to a GND plane. Provide as many as possible vias for heat transfer to GND plane.

Table 2.1 Low voltage digital and analog power supply pins

Pin	Number	Type	Function
CPO	35	O(VCC)	Charge pump driver output. Outputs 5V (GND to VCC) square wave with 1/16 of internal oscillator frequency.
CPI	36	I(VCP)	Charge pump capacitor input: Provide external 22nF or 33nF / 50V capacitor to CPO.
VCP	37		Output of charge pump. Provide external 100nF capacitor to VS.

Table 2.2 Charge pump pins

Pin	Number	Type	Function
GND	1	I	unused input, tie to GND
GND	2	I	unused input, tie to GND
CSN/IO0	3	I/O	Chip select input of SPI interface, programmable IO in UART mode
SCK/IO1	4	I/O	Serial clock input of SPI interface, programmable IO in UART mode
SDI/IO2	5	I/O	Data input of SPI interface, programmable IO in UART mode
SDO	8	I/O	Data output of SPI interface (Tristate, enabled with CSN=0), mode configuration input in UART mode (0 = Normal mode, 1 = Single wire ring mode – SWIO_P is input, SWIO_N is output)
SWIOP	9	I/O	Single wire I/O (positive). Serial input in ring mode. Multi-purpose input in SPI mode or encoder 1 N input.
SWION	10	I/O	Single wire I/O (negative) for differential mode. Leave open in non-differential mode when operating at 5V IO voltage or tie to desired threshold voltage. Serial output in ring mode. Multi-purpose input in SPI mode or encoder 2 N input.
CLK	11	I	Clock input. Tie to GND using short wire for internal clock or supply external clock. The first high signal disables the internal oscillator until power down.
SWSEL	12	I	Interface selection input. Tie to GND for SPI mode, tie to VCC_IO for single wire (UART) interface mode.
NEXTADDR	24	I	Address increment (if tied high) for single wire (UART) mode. General purpose input in SPI mode
DIR2	25	I	Right reference switch input for motor 2, optional DIR input for STEP/DIR operation of motor 2 or encoder 2 B input
STEP2	26	I	Left reference switch input for motor 2, optional STEP input for STEP/DIR operation of motor 2
DIR1	27	I	Right reference switch input for motor 1, optional DIR input for STEP/DIR operation of motor 1 or encoder 2 A input
STEP1	28	I	Left reference switch input for motor 1, optional STEP input for STEP/DIR operation of motor 1
DRV_ENN	29	I	Enable input for motor drivers. The power stage becomes switched off (all motor outputs floating) when this pin becomes driven to a high level. Tie to GND for normal operation.
TST_MODE	48	I	Test mode input. Tie to GND using short wire.
-	13, 23, 38	N.C.	Unused pins – no internal electrical connection. Leave open or tie to GND for compatibility with future devices.

Table 2.3 Digital I/O pins (all related to VCC_IO supply)

Pin	Number	Type	Function
O2A1	14	O (VS)	Motor 2 coil A output 1
BR2A	15		Sense resistor connection for motor 2 coil A. Place sense resistor to GND near pin.
O2A2	16	O (VS)	Motor 2 coil A output 2
VS	17, 19		Motor supply voltage. Provide filtering capacity near pin with shortest loop to nearest GNDP pin (respectively via GND plane).
GNDP	18	GND	Power GND. Connect to GND plane near pin.
O2B1	20	O (VS)	Motor 2 coil B output 1
BR2B	21		Sense resistor connection for motor 2 coil B. Place sense resistor to GND near pin.
O2B2	22	O (VS)	Motor 2 coil B output 2
O1B2	39	O (VS)	Motor 1 coil B output 2
BR1B	40		Sense resistor connection for motor 1 coil B. Place sense resistor to GND near pin.
O1B1	41	O (VS)	Motor 1 coil B output 1
VS	42, 44		Motor supply voltage. Provide filtering capacity near pin with shortest loop to nearest GNDP pin (respectively via GND plane).
GNDP	43	GND	Power GND. Connect to GND plane near pin.
O1A2	45	O (VS)	Motor 1 coil A output 2
BR1A	46		Sense resistor connection for motor 1 coil A. Place sense resistor to GND near pin.
O1A1	47	O (VS)	Motor 1 coil A output 1

Table 2.4 Power driver pins

3 Sample Circuits

The sample circuits show the connection of the external components in different operation and supply modes. The connection of the bus interface and further digital signals is left out for clarity.

3.1 Standard Application Circuit

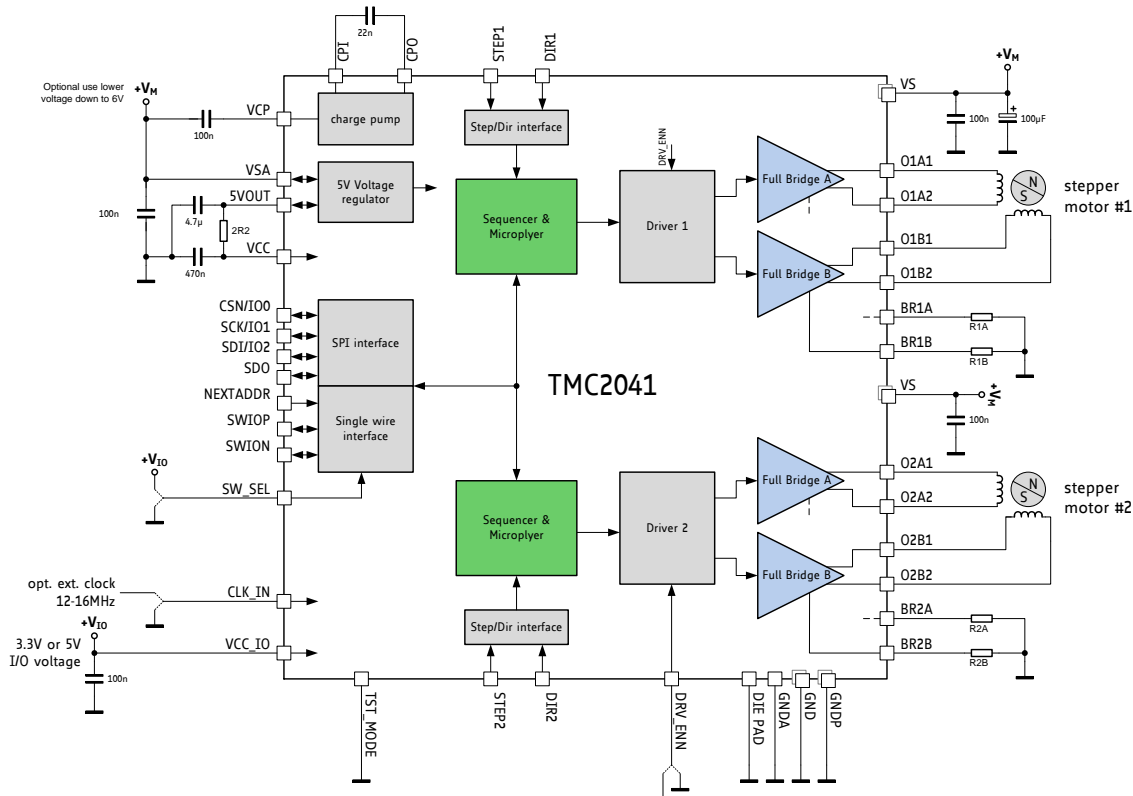

Figure 3.1 Standard application circuit

The standard application circuit uses a minimum set of additional components in order to operate the motor. Use low ESR capacitors for filtering the power supply which are capable to cope with the current ripple. The current ripple often depends on the power supply and cable length. The VCC_IO voltage can be supplied from 5VOUT, or from an external source, e.g. a low drop 3.3V regulator. In order to minimize linear voltage regulator power dissipation of the internal 5V voltage regulator in applications where VM is high, a different (lower) supply voltage can be used for VSA, if available. For example, many applications provide a 12V supply in addition to a higher supply voltage like 24V. Using the 12V supply for VSA will reduce the power dissipation of the internal 5V regulator to about 37% of the dissipation caused by supply with the full motor voltage. For best motor chopper performance, an optional R/C-filter de-couples 5VOUT from digital noise cause by power drawn from VCC.

Basic layout hints

Place sense resistors and all filter capacitors as close as possible to the related IC pins. Use a solid common GND for all GND connections, also for sense resistor GND. Connect 5VOUT filtering capacitor directly to 5VOUT and GNDPA pin. See layout hints for more details. Low ESR electrolytic capacitors are recommended for VS filtering.

Attention

In case VSA is supplied by a different voltage source, make sure that VSA does not exceed VS by more than one diode drop upon power up or power down.

3.2 5 V Only Supply

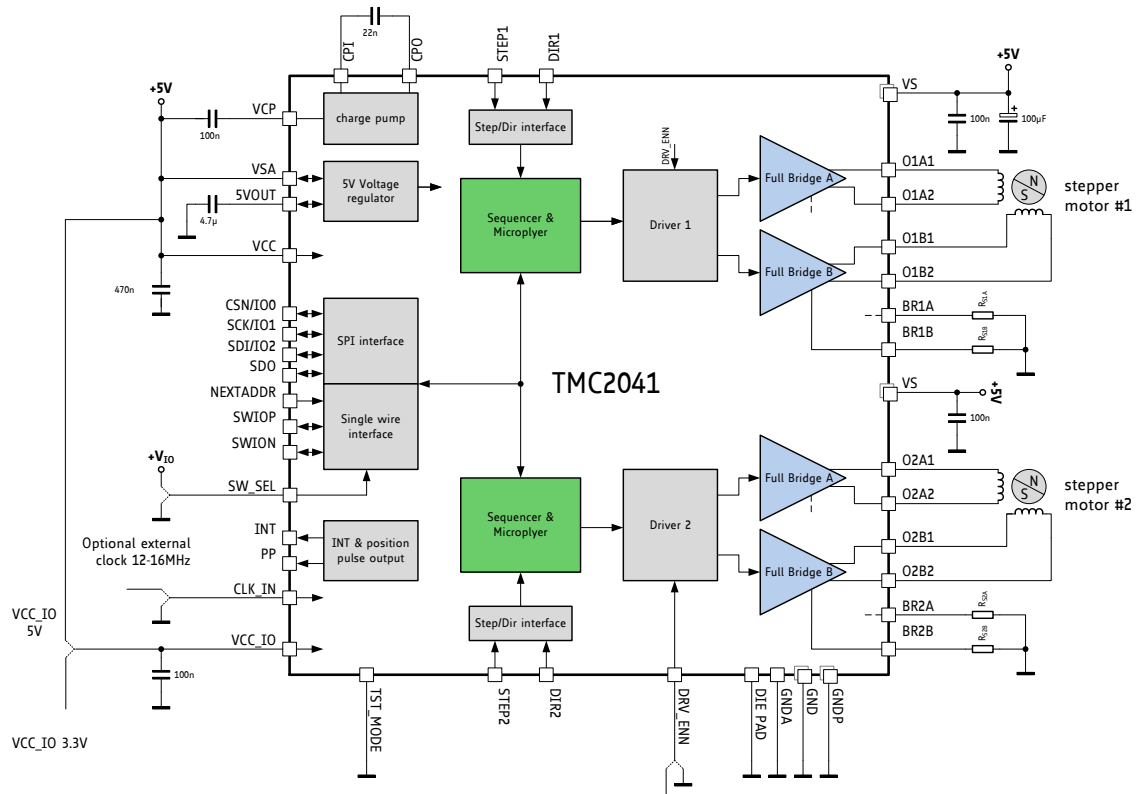

Figure 3.2 5V only operation

While the standard application circuit is limited to roughly 5.5V lower supply voltage, a 5V only application lets the IC run from a normal 5V +/-5% supply. In this application, linear regulator drop must be minimized. Therefore, the major 5V load is removed by supplying VCC directly from the external supply. In order to keep supply ripple away from the analog voltage reference, 5VOUT should have an own filtering capacity and the 5VOUT pin does not become bridged to the 5V supply.

3.3 One Motor with High Current

The TMC2041 supports double motor current for a single driver by paralleling both power stages. In order to operate in this mode, activate the flag *single_driver* in the global configuration register *GCONF*. This register can be locked for subsequent write access.

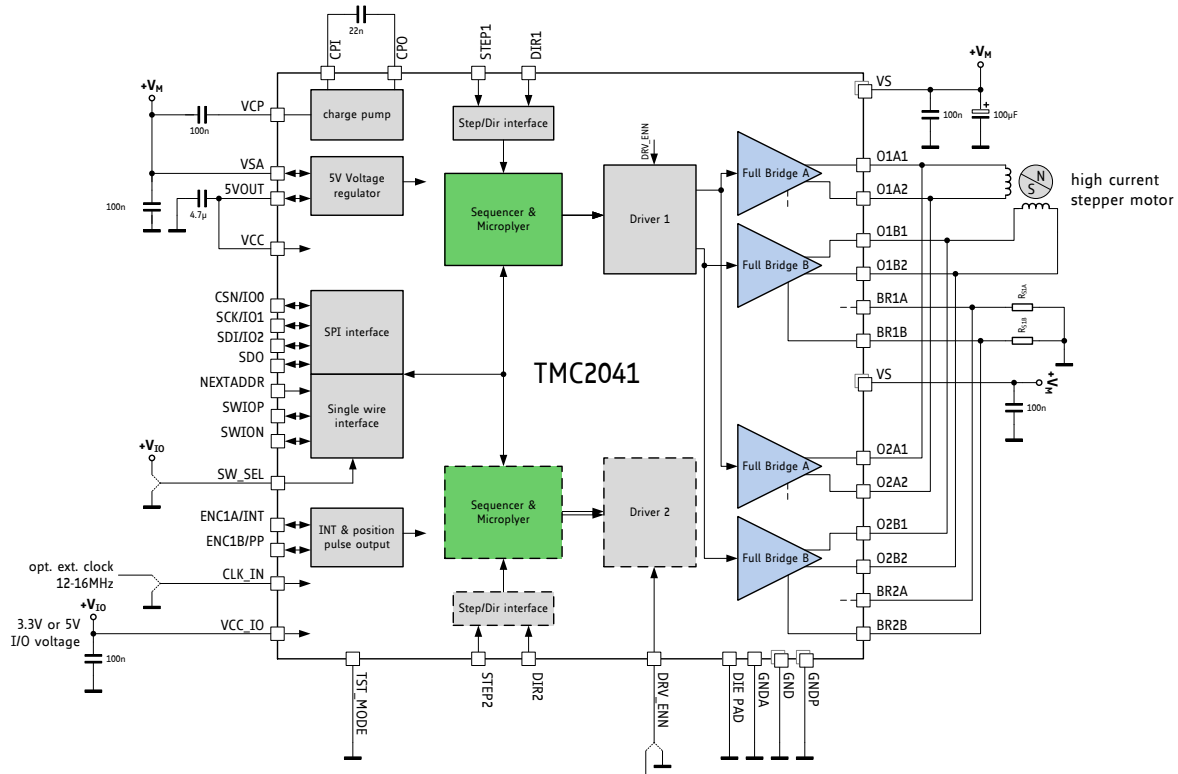

Figure 3.3 Driving a single motor with high current

3.4 External 5V Power Supply

When an external 5V power supply is available, the power dissipation caused by the internal linear regulator can be eliminated. This especially is beneficial in high voltage applications, and when thermal conditions are critical.

3.4.1 Internal Regulator Bridged

In case a clean external 5V supply is available, it can be used for complete supply of analog and digital part (Figure 3.4). The circuit will benefit from a well regulated supply, e.g. when using a +/-1% regulator. A precise supply guarantees increased motor current precision, because the voltage at 5VOUT directly is the reference voltage for all internal units of the driver, especially for motor current control. For best performance, the power supply should have low ripple to give a precise and stable supply at 5VOUT pin with remaining ripple well below 5mV. Some switching regulators have a higher remaining ripple, or different loads on the supply may cause lower frequency ripple. In this case, increase capacity attached to 5VOUT. In case the external supply voltage has poor stability or low frequency ripple, this would affect the precision of the motor current regulation as well as add chopper noise.

Well-regulated, stable supply, better than +5%

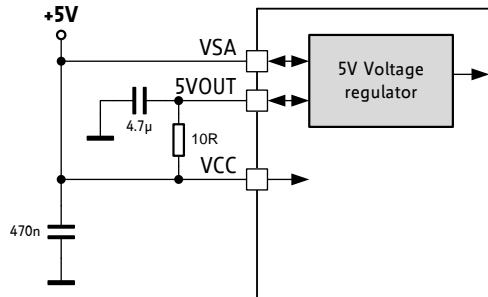

Figure 3.4 Using an external 5V supply to bypass internal regulator

3.5 Optimizing Analog Precision

The 5VOUT pin is used as an analog reference for operation of the TMC2041. Performance will degrade when there is voltage ripple on this pin. Most of the high frequency ripple in a TMC2041 design results from the operation of the internal digital logic. The digital logic switches with each edge of the clock signal. Further, ripple results from operation of the charge pump, which operates with roughly 1MHz and draws current from the VCC pin. In order to keep this ripple as low as possible, an additional filtering capacitor can be put directly next to the VCC pin with vias to the GND plane giving a short connection to the digital GND pins (pin 6 and pin 34). Analog performance is best, when this ripple is kept away from the analog supply pin 5VOUT, using an additional series resistor of 2.2Ω. The voltage drop on this resistor will be roughly 100mV ($I_{VCC} * R$).

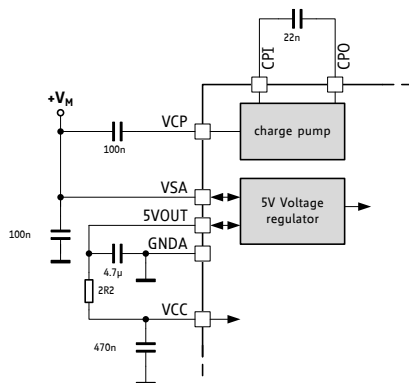

Figure 3.5 RC-Filter on VCC for reduced ripple

3.6 Driver Protection and EME Circuitry

Some applications have to cope with ESD events caused by motor operation or external influence. Despite ESD circuitry within the driver chips, ESD events occurring during operation can cause a reset or even a destruction of the motor driver, depending on their energy. Especially plastic housings and belt drive systems tend to cause ESD events. It is best practice to avoid ESD events by attaching all conductive parts, especially the motors themselves to PCB ground, or to apply electrically conductive plastic parts. In addition, the driver can be protected up to a certain degree against ESD events or live plugging / pulling the motor, which also causes high voltages and high currents into the motor connector terminals. A simple scheme uses capacitors at the driver outputs to reduce the dV/dt caused by ESD events. Larger capacitors will bring more benefit concerning ESD suppression, but cause additional current flow in each chopper cycle, and thus increase driver power dissipation, especially at high supply voltages. The values shown are example values – they might be varied between 100pF and 1nF. The capacitors also dampen high frequency noise injected from digital parts of the circuit and thus reduce electromagnetic emission. A more elaborate scheme uses LC filters to de-couple the driver outputs from the motor connector. Varistors in between of the coil terminals eliminate coil overvoltage caused by live plugging. Optionally protect all outputs by a varistor against ESD voltage.

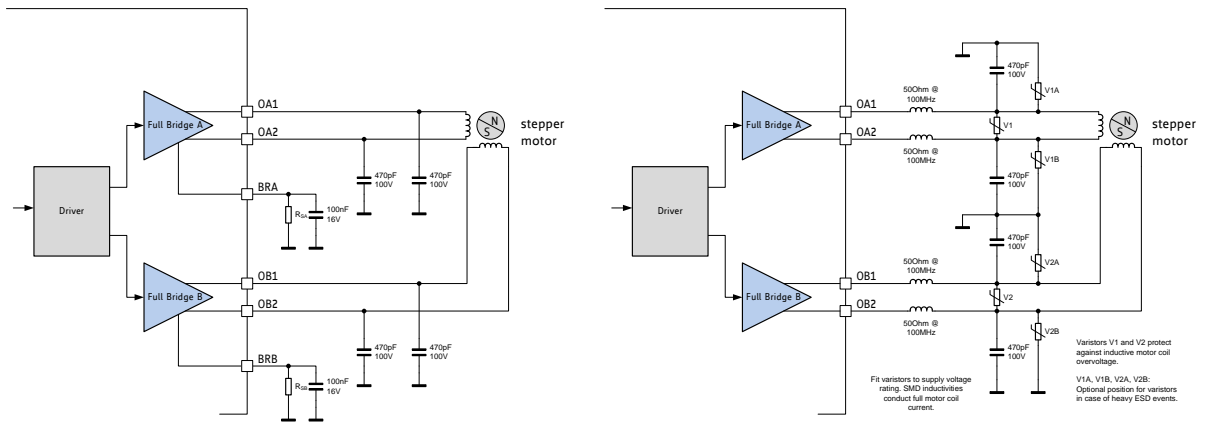

Figure 3.6 Simple ESD enhancement and more elaborate motor output protection

Example:

For a read access to the register (*XACTUAL*) with the address 0x21, the address byte has to be set to 0x21 in the access preceding the read access. For a write access to the register (*VACTUAL*), the address byte has to be set to 0x80 + 0x22 = 0xA2. For read access, the data bit might have any value (-). So, one can set them to 0.

action	data sent to TMC2041	data received from TMC2041
read <i>CHOPCONF1</i>	→ 0x6C00000000	← 0xSS & unused data
read <i>CHOPCONF1</i>	→ 0x6C00000000	← 0xSS & <i>CHOPCONF1</i>
write <i>CHOPCONF1</i> := 0x00ABCDEF	→ 0xEC00ABCDEF	← 0xSS & <i>CHOPCONF1</i>
write <i>CHOPCONF1</i> := 0x00123456	→ 0xEC00123456	← 0xSS00ABCDEF

*) S: is a placeholder for the status bits *SPI_STATUS*

4.1.2 SPI Status Bits Transferred with Each Datagram Read Back

New status information becomes latched at the end of each access and is available with the next SPI transfer.

<i>SPI_STATUS</i> – status flags transmitted with each SPI access in bits 39 to 32		
Bit	Name	Comment
7	-	reserved (0)
6	-	reserved (0)
5	-	reserved (0)
4	-	reserved (0)
3	-	reserved (0)
2	<i>driver_error(2)</i>	<i>GSTAT[2]</i> – 1: Signals driver 2 driver error (clear by reading <i>GSTAT</i>)
1	<i>driver_error(1)</i>	<i>GSTAT[1]</i> – 1: Signals driver 1 driver error (clear by reading <i>GSTAT</i>)
0	<i>reset_flag</i>	<i>GSTAT[0]</i> – 1: Signals, that a reset has occurred (clear by reading <i>GSTAT</i>)

4.1.3 Data Alignment

All data are right aligned. Some registers represent unsigned (positive) values, some represent integer values (signed) as two's complement numbers, single bits or groups of bits are represented as single bits respectively as integer groups.

4.2 SPI Signals

The SPI bus on the TMC2041 has four signals:

- SCK – bus clock input
- SDI – serial data input
- SDO – serial data output
- CSN – chip select input (active low)

The slave is enabled for an SPI transaction by a low on the chip select input CSN. Bit transfer is synchronous to the bus clock SCK, with the slave latching the data from SDI on the rising edge of SCK and driving data to SDO following the falling edge. The most significant bit is sent first. A minimum of 40 SCK clock cycles is required for a bus transaction with the TMC2041.

If more than 40 clocks are driven, the additional bits shifted into SDI are shifted out on SDO after a 40-clock delay through an internal shift register. This can be used for daisy chaining multiple chips.

CSN must be low during the whole bus transaction. When CSN goes high, the contents of the internal shift register are latched into the internal control register and recognized as a command from the master to the slave. If more than 40 bits are sent, only the last 40 bits received before the rising edge of CSN are recognized as the command.

4.3 Timing

The SPI interface is synchronized to the internal system clock, which limits the SPI bus clock SCK to half of the system clock frequency. If the system clock is based on the on-chip oscillator, an additional 10% safety margin must be used to ensure reliable data transmission. All SPI inputs as well as the ENN input are internally filtered to avoid triggering on pulses shorter than 20ns. Figure 4.1 shows the timing parameters of an SPI bus transaction, and the table below specifies their values.

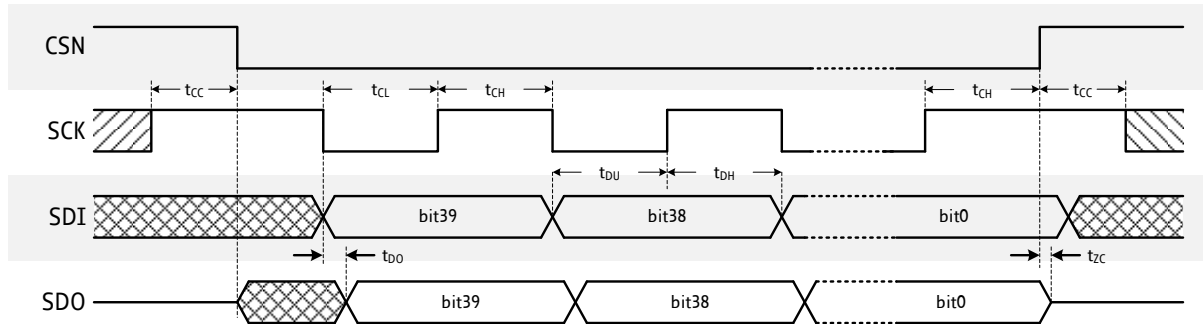

Figure 4.1 SPI timing

Hint
Usually this SPI timing is referred to as SPI MODE 3

SPI interface timing	AC-Characteristics					
	clock period: t_{CLK}					
Parameter	Symbol	Conditions	Min	Typ	Max	Unit
SCK valid before or after change of CSN	t_{CC}		10			ns
CSN high time	t_{CSH}	*) Min time is for synchronous CLK with SCK high one t_{CH} before CSN high only	$t_{CLK}^{*)}$	$>2t_{CLK}+10$		ns
SCK low time	t_{CL}	*) Min time is for synchronous CLK only	$t_{CLK}^{*)}$	$>t_{CLK}+10$		ns
SCK high time	t_{CH}	*) Min time is for synchronous CLK only	$t_{CLK}^{*)}$	$>t_{CLK}+10$		ns
SCK frequency using internal clock	f_{SCK}	assumes minimum OSC frequency			4	MHz
SCK frequency using external 16MHz clock	f_{SCK}	assumes synchronous CLK			8	MHz
SDI setup time before rising edge of SCK	t_{DU}		10			ns
SDI hold time after rising edge of SCK	t_{DH}		10			ns
Data out valid time after falling SCK clock edge	t_{DO}	no capacitive load on SDO			$t_{FILT}+5$	ns
SDI, SCK and CSN filter delay time	t_{FILT}	rising and falling edge	12	20	30	ns

5 UART Single Wire Interface

The UART single wire interface allows the control of the TMC2041 with any microcontroller UART. It shares transmit and receive line like an RS485 based interface. Data transmission is secured using a cyclic redundancy check, so that increased interface distances (e.g. over cables between two PCBs) can be bridged without the danger of wrong or missed commands even in the event of electro-magnetic disturbance. The automatic baud rate detection and an advanced addressing scheme make this interface easy and flexible to use.

5.1 Datagram Structure

5.1.1 Write Access

UART WRITE ACCESS DATAGRAM STRUCTURE																			
each byte is LSB...MSB, highest byte transmitted first																			
0 ... 63																			
sync + reserved					8 bit slave address			RW + 7 bit register addr.			32 bit data			CRC					
0...7					8...15			16...23			24...55			56...63					
1	0	1	0	Reserved (don't cares but included in CRC)			SLAVEADDR			register address	1	data bytes 3, 2, 1, 0 (high to low byte)			CRC				
0	1	2	3	4	5	6	7	8	:	15	16	:	23	24	:	55	56	:	63

A sync nibble precedes each transmission to and from the TMC2041 and is embedded into the first transmitted byte, followed by an addressing byte. Each transmission allows a synchronization of the internal baud rate divider to the master clock. The actual baud rate is adapted and variations of the internal clock frequency are compensated. Thus, the baud rate can be freely chosen within the valid range. Each transmitted byte starts with a start bit (logic 0, low level on SWIOP) and ends with a stop bit (logic 1, high level on SWIOP). The bit time is calculated by measuring the time from the beginning of start bit (1 to 0 transition) to the end of the sync frame (1 to 0 transition from bit 2 to bit 3). All data is transmitted byte wise. The 32 bit data words are transmitted with the highest byte first.

A minimum baud rate of 9000 baud is permissible, assuming 20 MHz clock (worst case for low baud rate). Maximum baud rate is $f_{CLK}/16$ due to the required stability of the baud clock.

The slave address is determined by the register *SLAVEADDR*. If the external address pin *NEXTADDR* is set, the slave address becomes incremented by one.

The communication becomes reset if a pause time of longer than 63 bit times between the start bits of two successive bytes occurs. This timing is based on the last correctly received datagram. In this case, the transmission needs to be restarted after a failure recovery time of minimum 12 bit times of bus idle time. This scheme allows the master to reset communication in case of transmission errors. Any pulse on an idle data line below 16 clock cycles will be treated as a glitch and leads to a timeout of 12 bit times, for which the data line must be idle. Other errors like wrong CRC are also treated the same way. This allows a safe re-synchronization of the transmission after any error conditions. Remark, that due to this mechanism, an abrupt reduction of the baud rate to less than 15 percent of the previous value is not possible.

Each accepted write datagram becomes acknowledged by the receiver by incrementing an internal cyclic datagram counter (8 bit). Reading out the datagram counter allows the master to check the success of an initialization sequence or single write accesses. Read accesses do not modify the counter.

5.1.2 Read Access

UART READ ACCESS REQUEST DATAGRAM STRUCTURE																
each byte is LSB...MSB, highest byte transmitted first																
sync + reserved					8 bit slave address			RW + 7 bit register address				CRC				
0...7					8...15			16...23				24...31				
1	0	1	0	Reserved (don't cares but included in CRC)				SLAVEADDR			register address		0	CRC		
0	1	2	3	4	5	6	7	8	..	15	16	..	23	24	..	31

The read access request datagram structure is identical to the write access datagram structure, but uses a lower number of user bits. Its function is the addressing of the slave and the transmission of the desired register address for the read access. The TMC2041 responds with the same baud rate as the master uses for the read request.

In order to ensure a clean bus transition from the master to the slave, the TMC2041 does not immediately send the reply to a read access, but it uses a programmable delay time after which the first reply byte becomes sent following a read request. This delay time can be set in multiples of eight bit times using *SENDDelay* time setting (default=8 bit times) according to the needs of the master. In a multi-slave system, set *SENDDelay* to min. 2 for all slaves. Otherwise a non-addressed slave might detect a transmission error upon read access to a different slave.

UART READ ACCESS REPLY DATAGRAM STRUCTURE																			
each byte is LSB...MSB, highest byte transmitted first																			
0 63																			
sync + reserved					8 bit slave address			RW + 7 bit register addr.		32 bit data			CRC						
0...7					8...15			16...23		24...55			56...63						
1	0	1	0	reserved (0)				0xFF			register address		0	data bytes 3, 2, 1, 0 (high to low byte)			CRC		
0	1	2	3	4	5	6	7	8	..	15	16	..	23	24	..	55	56	..	63

The read response is sent to the master using address code %1111. The transmitter becomes switched inactive four bit times after the last bit is sent.

Address %11111111 is reserved for read accesses going to the master. A slave cannot use this address.

ERRATA IN READ ACCESS

A known bug in the UART interface implementation affects read access to registers that change during the access. While the SPI interface takes a snapshot of the read register before transmission, the UART interface transfers the register directly MSB to LSB without taking a snapshot. This may lead to inconsistent data when reading out a register that changes during the transmission. Further, the CRC sent from the driver may be incorrect in this case (but must not), which will lead to the master repeating the read access. As a workaround, it is advised not to read out quickly changing registers like *XACTUAL*, *MSCNT* or *X_ENC* during a motion, but instead first stop the motor or check the *position_reached* flag to become active, and read out these values afterwards. If possible, use *X_LATCH* and *ENC_LATCH* for a safe readout during motion (e.g. for homing). As the encoder cannot be guaranteed to stand still during motor stop, only a dual read access and check for identical result ensures correct *X_ENC* read data. Therefore it is advised to use the latching function instead. Use the *vzero* and *velocity_reached* flag rather than reading *VACTUAL*.

5.2 CRC Calculation

An 8 bit CRC polynomial is used for checking both read and write access. It allows detection of up to eight single bit errors. The CRC8-ATM polynomial with an initial value of zero is applied LSB to MSB, including the sync- and addressing byte. The sync nibble is assumed to always be correct. The TMC2041 responds only to correctly transmitted datagrams containing its own slave address. It increases its datagram counter for each correctly received write access datagram.

$$CRC = x^8 + x^2 + x^1 + x^0$$

SERIAL CALCULATION EXAMPLE

`CRC = (CRC << 1) OR (CRC.7 XOR CRC.1 XOR CRC.0 XOR [new incoming bit])`

C-CODE EXAMPLE FOR CRC CALCULATION

```
void swuart_calcCRC(UCHAR* datagram, UCHAR datagramLength)
{
  int i,j;
  UCHAR* crc = datagram + (datagramLength-1); // CRC located in last byte of message
  UCHAR currentByte;

  *crc = 0;
  for (i=0; i<(datagramLength-1); i++) { // Execute for all bytes of a message
    currentByte = datagram[i]; // Retrieve a byte to be sent from Array
    for (j=0; j<8; j++) {
      if ((*crc >> 7) ^ (currentByte&0x01)) // update CRC based result of XOR operation
      {
        *crc = (*crc << 1) ^ 0x07;
      }
      else
      {
        *crc = (*crc << 1);
      }
      currentByte = currentByte >> 1;
    } // for CRC bit
  } // for message byte
}
```

5.3 UART Signals

The UART interface on the TMC2041 has following signals:

TMC2041 UART INTERFACE SIGNALS	
SWIOP	Non-inverted data input and output
SWION	Inverted data input and output for use in differential transmission. Can be left open in a 5V IO voltage system. Tie to the half IO level voltage for best performance in a 3.3V single wire non-differential application.
NEXTADDR	Address increment pin for sequential addressing scheme
SDO	Configuration input: Tie low for standard mode!

In UART mode (SW_SEL high) the slave checks the single wire SWIOP and SWION for correctly received datagrams with its own address continuously. Both signals are switched as input during this time. It adapts to the baud rate based on the sync nibble, as described before. In case of a read access, it switches on its output drivers on SWIOP and SWION and sends its response using the same baud rate.

5.4 Addressing Multiple Slaves

ADDRESSING ONE OR TWO SLAVES

If only one or two TMC2041 are addressed by a master using a single UART interface, a hardware address selection can be done by *setting the NEXTADDR pins to different levels*.

ADDRESSING UP TO 255 SLAVES

A different approach can address any number of devices by *using the input NEXTADDR as a selection pin*. Addressing up to 255 units is possible.

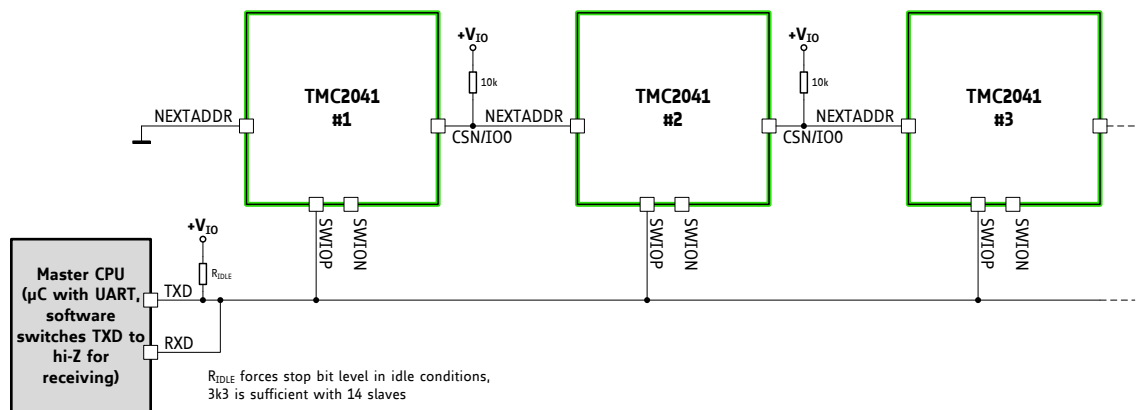

EXAMPLE FOR ADDRESSING UP TO 255 TMC2041

Addressing phase 1:	address 0, I00 is high-Z	address 1	address 1
Addressing phase 2:	program to address 254 & set I00 low	address 0, I00 is high-Z	address 1
Addressing phase 3:	address 254	program to address 253 & set I00 low	address 0
Addressing phase 4:	address 254	address 253	program to address 252 & set I00 low
Addressing phase X:	continue procedure		

Figure 5.1 Addressing multiple TMC2041 via single wire interface using chaining

Proceed as follows:

- Tie the NEXTADDR pin of your first TMC2041 to GND.
- Interconnect one of the general purpose IO-pins of the first TMC2041 to the next drivers NEXTADDR pin using an additional pull-up resistor. Connect further drivers in the same fashion.
- Now, the first driver responds to address 0. Following drivers are set to address 1.
- Program the first driver to its dedicated slave address. Note: once a driver is initialized with its slave address, its general purpose output, which is tied to the next drivers NEXTADDR has to be programmed as output and set to 0.
- Now, the second driver is accessible and can get its slave address. Further units can be programmed to their slave addresses sequentially.

6 Register Mapping

This chapter gives an overview of the complete register set. Some of the registers bundling a number of single bits are detailed in extra tables. The functional practical application of the settings is detailed in dedicated chapters.

Note

- All registers become reset to 0 upon power up, unless otherwise noted.
- Add 0x80 to the address **Addr** for write accesses!

NOTATION OF HEXADECIMAL AND BINARY NUMBERS

0x	precedes a hexadecimal number, e.g. 0x04
%	precedes a multi-bit binary number, e.g. %100

NOTATION OF R/W FIELD

R	Read only
W	Write only
R/W	Read- and writable register
R+C	Clear upon read

OVERVIEW REGISTER MAPPING

REGISTER	DESCRIPTION
General Configuration Registers	These registers contain <ul style="list-style-type: none"> - global configuration - global status flags - slave address configuration - and I/O configuration
Current Setting	This register set offers registers for <ul style="list-style-type: none"> - driver current control and hold current
Motor Driver Register Set	This register set offers registers for <ul style="list-style-type: none"> - chopper and driver configuration - coolStep and stallGuard2 configuration

6.1 General Configuration Registers

GENERAL CONFIGURATION REGISTERS (0x00...0x0F)					
R/W	Addr	n	Register	Description / bit names	
RW	0x00	10	GCONF	Bit GCONF – Global configuration flags	
				0	<i>single_driver</i> 0: Two motors can be operated. 1: Single motor, double current operation - driver 2 outputs are identical to driver 1, all driver 2 related controls are unused in this mode. <i>Attention: Set correctly before driver enable!</i>
				1	<i>stepdir1_enable</i> 0: Driver 1 does not accept steps. 1: Step/Dir interface enabled via STEP1 and DIR1
				2	<i>stepdir2_enable</i> 0: Driver 2 does not accept steps. 1: Step/Dir interface enabled via STEP2 and DIR2
				3	<i>reserved</i> set to 0
				4	<i>reserved</i> set to 0
				5	<i>reserved</i> set to 0
				6	<i>reserved</i> set to 0
				7	<i>test_mode</i> 0: Normal operation 1: Enable analog test output on pin REFR2 SLAVEADDR selects the function of REFR2: 0...4: T120, DAC1, VDDH1, DAC2, VDDH2 <i>Attention: Not for user, set to 0 for normal operation!</i>
				8	<i>shaft1</i> 1: Inverse motor 1 direction
				9	<i>shaft2</i> 1: Inverse motor 2 direction
10	<i>lock_gconf</i> 1: GCONF is locked against further write access.				

GENERAL CONFIGURATION REGISTERS (0x00...0x0F)																										
R/W	Addr	n	Register	Description / bit names																						
R+C	0x01	4	GSTAT	<table border="1"> <thead> <tr> <th>Bit</th> <th>GSTAT – Global status flags</th> </tr> </thead> <tbody> <tr> <td>0</td> <td> <i>reset</i> 1: Indicates that the IC has been reset since the last read access to GSTAT. All registers have been cleared to reset values. </td> </tr> <tr> <td>1</td> <td> <i>drv_err1</i> 1: Indicates, that driver 1 has been shut down due to overtemperature or short circuit detection since the last read access. Read <i>DRV_STATUS1</i> for details. The flag can only be reset when all error conditions are cleared. </td> </tr> <tr> <td>2</td> <td> <i>drv_err2</i> 1: Indicates, that driver 2 has been shut down due to overtemperature or short circuit detection since the last read access. Read <i>DRV_STATUS2</i> for details. The flag can only be reset when all error conditions are cleared. </td> </tr> <tr> <td>3</td> <td> <i>uv_cp</i> 1: Indicates an undervoltage on the charge pump. The driver is disabled in this case. </td> </tr> </tbody> </table>	Bit	GSTAT – Global status flags	0	<i>reset</i> 1: Indicates that the IC has been reset since the last read access to GSTAT. All registers have been cleared to reset values.	1	<i>drv_err1</i> 1: Indicates, that driver 1 has been shut down due to overtemperature or short circuit detection since the last read access. Read <i>DRV_STATUS1</i> for details. The flag can only be reset when all error conditions are cleared.	2	<i>drv_err2</i> 1: Indicates, that driver 2 has been shut down due to overtemperature or short circuit detection since the last read access. Read <i>DRV_STATUS2</i> for details. The flag can only be reset when all error conditions are cleared.	3	<i>uv_cp</i> 1: Indicates an undervoltage on the charge pump. The driver is disabled in this case.												
				Bit	GSTAT – Global status flags																					
				0	<i>reset</i> 1: Indicates that the IC has been reset since the last read access to GSTAT. All registers have been cleared to reset values.																					
				1	<i>drv_err1</i> 1: Indicates, that driver 1 has been shut down due to overtemperature or short circuit detection since the last read access. Read <i>DRV_STATUS1</i> for details. The flag can only be reset when all error conditions are cleared.																					
2	<i>drv_err2</i> 1: Indicates, that driver 2 has been shut down due to overtemperature or short circuit detection since the last read access. Read <i>DRV_STATUS2</i> for details. The flag can only be reset when all error conditions are cleared.																									
3	<i>uv_cp</i> 1: Indicates an undervoltage on the charge pump. The driver is disabled in this case.																									
R	0x02	8	IFCNT	Interface transmission counter. This register becomes incremented with each successful UART interface write access. It can be read out to check the serial transmission for lost data. Read accesses do not change the content. Disabled in SPI operation. The counter wraps around from 255 to 0.																						
W	0x03	8 + 4	SLAVECONF	<table border="1"> <thead> <tr> <th>Bit</th> <th>SLAVECONF</th> </tr> </thead> <tbody> <tr> <td>7..0</td> <td> <i>SLAVEADDR</i>: Sets the address of unit for the UART interface. The address becomes incremented by one when the external address pin NEXTADDR is active. Range: 0-253 (254), <i>default=0</i> In ring mode, 0 disables forwarding. </td> </tr> <tr> <td>11..8</td> <td> <i>SENDDelay</i>: 0, 1: 8 bit times (not allowed with multiple slaves) 2, 3: 3*8 bit times 4, 5: 5*8 bit times 6, 7: 7*8 bit times 8, 9: 9*8 bit times 10, 11: 11*8 bit times 12, 13: 13*8 bit times 14, 15: 15*8 bit times </td> </tr> </tbody> </table>	Bit	SLAVECONF	7..0	<i>SLAVEADDR</i> : Sets the address of unit for the UART interface. The address becomes incremented by one when the external address pin NEXTADDR is active. Range: 0-253 (254), <i>default=0</i> In ring mode, 0 disables forwarding.	11..8	<i>SENDDelay</i> : 0, 1: 8 bit times (not allowed with multiple slaves) 2, 3: 3*8 bit times 4, 5: 5*8 bit times 6, 7: 7*8 bit times 8, 9: 9*8 bit times 10, 11: 11*8 bit times 12, 13: 13*8 bit times 14, 15: 15*8 bit times																
				Bit	SLAVECONF																					
7..0	<i>SLAVEADDR</i> : Sets the address of unit for the UART interface. The address becomes incremented by one when the external address pin NEXTADDR is active. Range: 0-253 (254), <i>default=0</i> In ring mode, 0 disables forwarding.																									
11..8	<i>SENDDelay</i> : 0, 1: 8 bit times (not allowed with multiple slaves) 2, 3: 3*8 bit times 4, 5: 5*8 bit times 6, 7: 7*8 bit times 8, 9: 9*8 bit times 10, 11: 11*8 bit times 12, 13: 13*8 bit times 14, 15: 15*8 bit times																									
R	0x04	9 + 8	INPUT	<table border="1"> <thead> <tr> <th>Bit</th> <th>INPUT</th> </tr> </thead> <tbody> <tr> <td></td> <td>Reads the digital state of all input pins available plus the state of IO pins set to output.</td> </tr> <tr> <td>0</td> <td><i>io0_in</i>: IO0 polarity</td> </tr> <tr> <td>1</td> <td><i>io1_in</i>: IO1 polarity</td> </tr> <tr> <td>2</td> <td><i>io2_in</i>: IO2 polarity</td> </tr> <tr> <td>3</td> <td><i>io3_in</i>: IO3 polarity</td> </tr> <tr> <td>4</td> <td><i>iop_in</i>: IOP pin polarity (always input in SPI mode)</td> </tr> <tr> <td>5</td> <td><i>ion_in</i>: ION pin polarity (always input in SPI mode)</td> </tr> <tr> <td>6</td> <td><i>nextaddr_in</i>: NEXTADDR pin polarity</td> </tr> <tr> <td>7</td> <td><i>drv_enn_in</i>: DRV_ENN pin polarity</td> </tr> <tr> <td>8</td> <td><i>sw_comp_in</i>: UART input comparator (1: IOP voltage is above ION voltage). The accuracy is about 20mV.</td> </tr> </tbody> </table>	Bit	INPUT		Reads the digital state of all input pins available plus the state of IO pins set to output.	0	<i>io0_in</i> : IO0 polarity	1	<i>io1_in</i> : IO1 polarity	2	<i>io2_in</i> : IO2 polarity	3	<i>io3_in</i> : IO3 polarity	4	<i>iop_in</i> : IOP pin polarity (always input in SPI mode)	5	<i>ion_in</i> : ION pin polarity (always input in SPI mode)	6	<i>nextaddr_in</i> : NEXTADDR pin polarity	7	<i>drv_enn_in</i> : DRV_ENN pin polarity	8	<i>sw_comp_in</i> : UART input comparator (1: IOP voltage is above ION voltage). The accuracy is about 20mV.
Bit	INPUT																									
	Reads the digital state of all input pins available plus the state of IO pins set to output.																									
0	<i>io0_in</i> : IO0 polarity																									
1	<i>io1_in</i> : IO1 polarity																									
2	<i>io2_in</i> : IO2 polarity																									
3	<i>io3_in</i> : IO3 polarity																									
4	<i>iop_in</i> : IOP pin polarity (always input in SPI mode)																									
5	<i>ion_in</i> : ION pin polarity (always input in SPI mode)																									
6	<i>nextaddr_in</i> : NEXTADDR pin polarity																									
7	<i>drv_enn_in</i> : DRV_ENN pin polarity																									
8	<i>sw_comp_in</i> : UART input comparator (1: IOP voltage is above ION voltage). The accuracy is about 20mV.																									

GENERAL CONFIGURATION REGISTERS (0x00...0x0F)				
R/W	Addr	n	Register	Description / bit names
				31..24 <i>VERSION</i> : 0x10=version of the IC Identical numbers mean full digital compatibility.
W		4 + 4	<i>OUTPUT</i>	Bit <i>OUTPUT</i> Sets the IO output pin polarity and data direction.
				0 <i>io0_out</i> : IO0 output polarity
				1 <i>io1_out</i> : IO1 output polarity
				2 <i>io2_out</i> : IO2 output polarity
				3 -
				8 <i>iaddr0</i> (IO0: 0=input, 1=output)
				9 <i>iaddr1</i> (IO1: 0=input, 1=output)
				10 <i>iaddr2</i> (IO2: 0=input, 1=output)
				11 - (IO3 is always input)

Addresses **Addr** are specified for motor 1 (upper value) and motor 2 (second address).

6.2 Current Setting

RAMP GENERATOR DRIVER FEATURE CONTROL REGISTER SET (MOTOR 1: 0x30...0x36, MOTOR 2: 0x50...0x56)				
R/W	Addr	n	Register	Description / bit names
W	0x30 0x50	5 + 5 + 4	<i>IHOLD_IRUN</i>	Bit <i>IHOLD_IRUN</i> – Driver current control
				4..0 <i>IHOLD</i> Standstill current (0=1/32...31=32/32)
				12..8 <i>IRUN</i> Motor run current (0=1/32...31=32/32) <i>Hint</i> : Choose sense resistors in a way, that normal <i>IRUN</i> is 16 to 31 for best microstep performance.
				19..16 <i>IHOLDDELAY</i> Controls the number of clock cycles for motor power down after a motion as soon as <i>TZEROWAIT</i> has expired. The smooth transition avoids a motor jerk upon power down. 0: instant power down 1..15: Delay per current reduction step in multiple of 2 ¹⁸ clocks

6.3 Motor Driver Registers

MOTOR DRIVER REGISTER SET (MOTOR 1: 0x6A...0x6F, MOTOR 2: 0x7A...0x7F)					
R/W	Addr	n	Register	Description / bit names	Range [Unit]
R	0x6A 0x7A	10	<i>MSCNT</i>	Microstep counter. Indicates actual position in the microstep table for <i>CUR_A</i> . <i>CUR_B</i> uses an offset of 256. <i>Hint:</i> Move to a position where <i>MSCNT</i> is zero before re-initializing <i>MSLUTSTART</i> or <i>MSLUT</i> and <i>MSLUTSEL</i> .	0...1023
R	0x6B 0x7B	9 + 9	<i>MSCURACT</i>	bit 8... 0: <i>CUR_A</i> (signed): Actual microstep current for motor phase A as read from <i>MSLUT</i> (not scaled by current) bit 24... 16: <i>CUR_B</i> (signed): Actual microstep current for motor phase B as read from <i>MSLUT</i> (not scaled by current)	+/-0...255
RW	0x6C 0x7C	32	<i>CHOPCONF</i>	chopper and driver configuration <i>See separate table!</i>	
W	0x6D 0x7D	25	<i>COOLCONF</i>	coolStep smart current control register and stallGuard2 configuration <i>See separate table!</i>	
R	0x6F 0x7F	32	<i>DRV_STATUS</i>	stallGuard2 value and driver error flags <i>See separate table!</i>	

6.3.1 CHOPCONF – Chopper Configuration

0x6C, 0x7C: CHOPCONF – CHOPPER CONFIGURATION				
Bit	Name	Function	Comment	
31	-	reserved	set to 0	
30	<i>diss2g</i>	short to GND protection disable	0: Short to GND protection is on 1: Short to GND protection is disabled	
29	<i>dedge</i>	enable double edge step pulses	1: Enable step impulse at each step edge to reduce step frequency requirement.	
28	<i>intpol16</i>	16 microsteps with interpolation	1: In 16 microstep mode, the microstep resolution becomes extrapolated to 256 microsteps for smoothest motor operation	
27	<i>mres3</i>	MRES micro step resolution	%0000: Native 256 microstep setting. %0001 ... %1000: 128, 64, 32, 16, 8, 4, 2, FULLSTEP Reduced microstep resolution. The resolution gives the number of microstep entries per sine quarter wave. Especially when switching to a low resolution of 8 microsteps and below, take care to switch at certain microstep positions. The switching position determines the sequence of patterns. step width=2^MRES [microsteps]	
26	<i>mres2</i>			
25	<i>mres1</i>			
24	<i>mres0</i>			
23	-	reserved	set to 0	
22	-			
21	-			
20	-			
19	-	reserved	set to 0	
18	-	reserved	set to 0	
17	<i>vsense</i>	sense resistor voltage based current scaling	0: Low sensitivity, high sense resistor voltage 1: High sensitivity, low sense resistor voltage	
16	<i>tbl1</i>	TBL blank time select	%00 ... %11: Set comparator blank time to 16, 24, 36 or 54 clocks <i>Hint:</i> %01 or %10 recommended for most applications	
15	<i>tbl0</i>			
14	<i>chm</i>	chopper mode	0	Standard mode (spreadCycle)
			1	Constant off time with fast decay time. Fast decay time is also terminated when the negative nominal current is reached. Fast decay is after on time.
13	<i>rndtf</i>	random TOFF time	0	Chopper off time is fixed as set by TOFF
			1	Random mode, TOFF is random modulated by $dN_{CLK} = -12 \dots +3$ clocks.
12	<i>disfdcc</i>	fast decay mode	<i>chm</i> =1: <i>disfdcc</i> =1 disables current comparator usage for termination of the fast decay cycle	

0x6C, 0x7C: <i>CHOPCONF</i> – CHOPPER CONFIGURATION			
Bit	Name	Function	Comment
11	<i>fd3</i>	<i>TFD</i> [3]	<i>chm</i> =1: MSB of fast decay time setting <i>TFD</i>
10	<i>hend3</i>	<i>HEND</i> hysteresis low value <i>OFFSET</i> sine wave offset	<i>chm</i> =0 %0000 ... %1111: Hysteresis is -3, -2, -1, 0, 1, ..., 12 (1/512 of this setting adds to current setting) This is the hysteresis value which becomes used for the hysteresis chopper.
9	<i>hend2</i>		
8	<i>hend1</i>		
7	<i>hend0</i>		<i>chm</i> =1 %0000 ... %1111: Offset is -3, -2, -1, 0, 1, ..., 12 This is the sine wave offset and 1/512 of the value becomes added to the absolute value of each sine wave entry.
6	<i>hstrt2</i>	<i>HSTRT</i> hysteresis start value added to <i>HEND</i>	<i>chm</i> =0 %000 ... %111: Add 1, 2, ..., 8 to hysteresis low value <i>HEND</i> (1/512 of this setting adds to current setting) <i>Attention: Effective HEND+HSTRT ≤ 16.</i> <i>Hint:</i> Hysteresis decrement is done each 16 clocks
5	<i>hstrt1</i>		
4	<i>hstrt0</i>		
		<i>TFD</i> [2..0] fast decay time setting	<i>chm</i> =1 Fast decay time setting (MSB: <i>fd3</i>): %0000 ... %1111: Fast decay time setting <i>TFD</i> with $N_{CLK} = 32 * HSTRT$ (%0000: slow decay only)
3	<i>toff3</i>	<i>TOFF</i> off time and driver enable	Off time setting controls duration of slow decay phase $N_{CLK} = 12 + 32 * TOFF$ %0000: Driver disable, all bridges off %0001: 1 – use only with $TBL ≥ 36$ clocks %0010 ... %1111: 2 ... 15
2	<i>toff2</i>		
1	<i>toff1</i>		
0	<i>toff0</i>		

6.3.2 COOLCONF – Smart Energy Control coolStep and stallGuard2

0x6D, 0x7D: COOLCONF – SMART ENERGY CONTROL COOLSTEP AND STALLGUARD2

Bit	Name	Function	Comment
...	-	reserved	set to 0
24	<i>sflt</i>	stallGuard2 filter enable	0 Standard mode, high time resolution for stallGuard2
			1 Filtered mode, stallGuard2 signal updated for each four fullsteps only to compensate for motor pole tolerances
23	-	reserved	set to 0
22	<i>sgt6</i>	stallGuard2 threshold value	This signed value controls stallGuard2 level for stall output and sets the optimum measurement range for readout. A lower value gives a higher sensitivity. Zero is the starting value working with most motors. -64 to +63: A higher value makes stallGuard2 less sensitive and requires more torque to indicate a stall.
21	<i>sgt5</i>		
20	<i>sgt4</i>		
19	<i>sgt3</i>		
18	<i>sgt2</i>		
17	<i>sgt1</i>		
16	<i>sgt0</i>		
15	<i>seimin</i>	minimum current for smart current control	0: 1/2 of current setting (<i>IRUN</i>) 1: 1/4 of current setting (<i>IRUN</i>)
14	<i>sedn1</i>	current down step speed	%00: For each 32 stallGuard2 values decrease by one %01: For each 8 stallGuard2 values decrease by one %10: For each 2 stallGuard2 values decrease by one %11: For each stallGuard2 value decrease by one
13	<i>sedn0</i>		
12	-	reserved	set to 0
11	<i>semax3</i>	stallGuard2 hysteresis value for smart current control	If the stallGuard2 result is equal to or above (<i>SEMIN+SEMAX+1</i>)*32, the motor current becomes decreased to save energy. %0000 ... %1111: 0 ... 15
10	<i>semax2</i>		
9	<i>semax1</i>		
8	<i>semax0</i>		
7	-	reserved	set to 0
6	<i>seup1</i>	current up step width	Current increment steps per measured stallGuard2 value %00 ... %11: 1, 2, 4, 8
5	<i>seup0</i>		
4	-	reserved	set to 0
3	<i>semin3</i>	minimum stallGuard2 value for smart current control and smart current enable	If the stallGuard2 result falls below <i>SEMIN</i> *32, the motor current becomes increased to reduce motor load angle. %0000: smart current control coolStep off %0001 ... %1111: 1 ... 15
2	<i>semin2</i>		
1	<i>semin1</i>		
0	<i>semin0</i>		

6.3.3 DRV_STATUS – stallGuard2 Value and Driver Error Flags

0x6F, 0x7F: DRV_STATUS – STALLGUARD2 VALUE AND DRIVER ERROR FLAGS			
Bit	Name	Function	Comment
31	<i>stst</i>	standstill indicator	This flag indicates motor stand still in each operation mode. It is especially useful for step & dir mode.
30	<i>olb</i>	open load indicator phase B	1: Open load detected on phase A or B. <i>Hint:</i> This is just an informative flag. The driver takes no action upon it. False detection may occur in fast motion and standstill. Check during slow motion or after a motion, only.
29	<i>ola</i>	open load indicator phase A	
28	<i>s2gb</i>	short to ground indicator phase B	1: Short to GND detected on phase A or B. The driver becomes disabled. The flags stay active, until the driver is disabled by software (<i>TOFF=0</i>) or by the ENN input.
27	<i>s2ga</i>	short to ground indicator phase A	
26	<i>otpw</i>	overtemperature pre-warning flag	1: Overtemperature pre-warning threshold is exceeded. The overtemperature pre-warning flag is common for both drivers.
25	<i>ot</i>	overtemperature flag	1: Overtemperature limit has been reached. Drivers become disabled until <i>otpw</i> is also cleared due to cooling down of the IC. The overtemperature flag is common for both drivers.
24	<i>stallGuard</i>	stallGuard2 status	1: Motor stall detected (<i>SG_RESULT=0</i>) or dcStep stall in dcStep mode.
23	-	reserved	Ignore these bits
22			
21			
20	<i>CS ACTUAL</i>	actual motor current / smart energy current	Actual current control scaling, for monitoring smart energy current scaling controlled via settings in register <i>COOLCONF</i> , or for monitoring the function of the automatic current scaling.
19			
18			
17			
16			
15	-	reserved	Ignore this bit
14	-	reserved	Ignore these bits
13			
12			
11			
10			
9	<i>SG_RESULT</i>	stallGuard2 result respectively PWM on time for coil A in stand still for motor temperature detection	<p>Mechanical load measurement:</p> <p>The stallGuard2 result gives a means to measure mechanical motor load. A higher value means lower mechanical load. A value of 0 signals highest load. With optimum <i>SGT</i> setting, this is an indicator for a motor stall. The stall detection compares <i>SG_RESULT</i> to 0 in order to detect a stall. <i>SG_RESULT</i> is used as a base for coolStep operation, by comparing it to a programmable upper and a lower limit.</p> <p>stallGuard2 works best with microstep operation.</p> <p>Temperature measurement:</p> <p>In standstill, no stallGuard2 result can be obtained. <i>SG_RESULT</i> shows the chopper on-time for motor coil A instead. If the motor is moved to a determined microstep position at a certain current setting, a comparison of the chopper on-time can help to get a rough estimation of motor temperature. As the motor heats up, its coil resistance rises and the chopper on-time increases.</p>
8			
7			
6			
5			
4			
3			
2			
1			
0			

7 Current Setting

The internal 5V supply voltage available at the pin 5VOUT is used as a reference for the coil current regulation based on the sense resistor voltage measurement. The desired maximum motor current is set by selecting an appropriate value for the sense resistor. The sense resistor voltage range can be selected by the *vsense* bit in *CHOPCONF*. The low sensitivity setting (high sense resistor voltage, *vsense*=0) brings best and most robust current regulation, while high sensitivity (low sense resistor voltage, *vsense*=1) reduces power dissipation in the sense resistor. The high sensitivity setting reduces the power dissipation in the sense resistor by nearly half.

After choosing the *vsense* setting and selecting the sense resistor, the currents to both coils are scaled by the 5-bit current scale parameters (*IHOLD*, *IRUN*). The sense resistor value is chosen so that the maximum desired current (or slightly more) flows at the maximum current setting (*IRUN* = %11111).

Using the internal sine wave table, which has the amplitude of 248, the RMS motor current can be calculated by:

$$I_{RMS} = \frac{CS + 1}{32} * \frac{V_{FS}}{R_{SENSE} + 20m\Omega} * \frac{1}{\sqrt{2}}$$

The momentary motor current is calculated by:

$$I_{MOT} = \frac{CUR_{A/B}}{248} * \frac{CS + 1}{32} * \frac{V_{FS}}{R_{SENSE} + 20m\Omega}$$

CS is the current scale setting as set by the *IHOLD* and *IRUN* and coolStep.

V_{FS} is the full scale voltage as determined by *vsense* control bit (please refer to electrical characteristics, V_{SRTL} and V_{SRTH}).

$CUR_{A/B}$ is the actual value from the internal sine wave table.

The internal resistance of 20mΩ will be increased by external trace resistance, 5mΩ are realistic.

CHOICE OF R_{SENSE} AND RESULTING MAX. MOTOR CURRENT		
R_{SENSE} [Ω]	RMS current [A] (<i>CS</i> =31, <i>vsense</i> =0)	RMS current [A] (<i>CS</i> =31, <i>vsense</i> =1)
1.00	0.21	0.12
0.82	0.26	0.15
0.75	0.28	0.16
0.68	0.31	0.18
0.50	0.42	0.24
0.47	0.45	0.25
0.33	0.63	0.35
0.27	0.76	0.43
0.22	0.91	0.51
0.15	1.29*)	0.72

*) Value exceeds upper current rating for single motor operation.

Hint

For best precision of current setting, it is advised to measure and fine tune the current in the application.

Parameter	Description	Setting	Comment
<i>IRUN</i>	Current scale when motor is running. Scales coil current values as taken from the internal sine wave table. For high precision motor operation, work with a current scaling factor in the range 16 to 31, because scaling down the current values reduces the effective microstep resolution by making microsteps coarser. This setting also controls the maximum current value set by <i>coolStep</i> .	0 ... 31	scaling factor 1/32, 2/32, ... 32/32
<i>IHOLD</i>	Identical to <i>IRUN</i> , but for motor in stand still.		
<i>IHOLD DELAY</i>	Allows smooth current reduction from run current to hold current. <i>IHOLDDELAY</i> controls the number of clock cycles for motor power down after <i>TZEROWAIT</i> in increments of 2 ¹⁸ clocks: 0=instant power down, 1..15: Current reduction delay per current step in multiple of 2 ¹⁸ clocks. <i>Example:</i> When using <i>IRUN</i> =31 and <i>IHOLD</i> =16, 15 current steps are required for hold current reduction. A <i>IHOLDDELAY</i> setting of 4 thus results in a power down time of 4*15*2 ¹⁸ clock cycles, i.e. roughly one second at 16MHz.	0 1 ...15	instant <i>IHOLD</i> 1*2 ¹⁸ ... 15*2 ¹⁸ clocks per current decrement
<i>vsense</i>	Allows control of the sense resistor <i>voltage range</i> for full scale current.	0 1	V _{FS} = 0.32 V V _{FS} = 0.18 V

7.1 Sense Resistors

Sense resistors should be carefully selected. The full motor current flows through the sense resistors. They also see the switching spikes from the MOSFET bridges. A low-inductance type such as film or composition resistors is required to prevent spikes causing ringing on the sense voltage inputs leading to unstable measurement results. A low-inductance, low-resistance PCB layout is essential. Any common GND path for the two sense resistors must be avoided, because this would lead to coupling between the two current sense signals. A massive ground plane is best. Please also refer to layout considerations in chapter 19.

The sense resistor needs to be able to conduct the peak motor coil current in motor standstill conditions, unless standby power is reduced. Under normal conditions, the sense resistor conducts less than the coil RMS current, because no current flows through the sense resistor during the slow decay phases.

The peak sense resistor power dissipation is:

$$P_{RSMAX} = I_{COIL}^2 * R_{SENSE}$$

For high current applications, power dissipation is halved by using the low *vsense* setting and using an adapted resistance value. Please be aware, that in this case any voltage drop in PCB traces has a larger influence on the result. A compact layout with massive ground plane is best to avoid parasitic resistance effects.

8 spreadCycle and Classic Chopper

spreadCycle is a cycle-by-cycle current control. Therefore, it can react extremely fast to changes in motor velocity or motor load. The currents through both motor coils are controlled using choppers. The choppers work independently of each other. In Figure 8.1 the different chopper phases are shown.

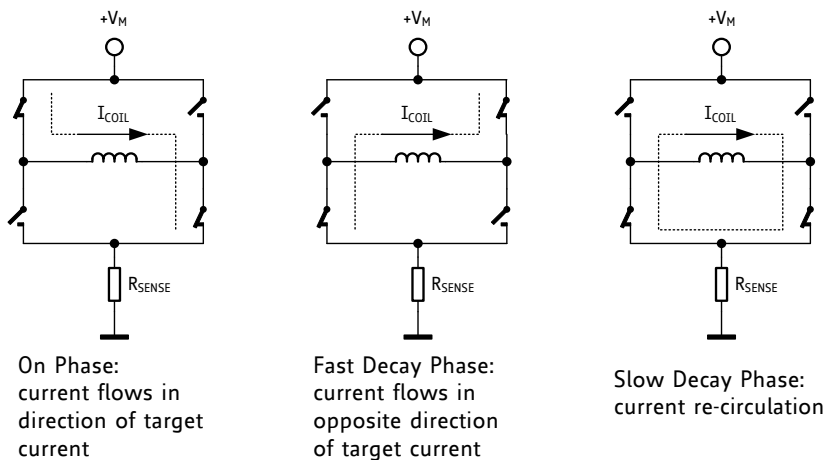

Figure 8.1 Chopper phases

Although the current could be regulated using only on phases and fast decay phases, insertion of the slow decay phase is important to reduce electrical losses and current ripple in the motor. The duration of the slow decay phase is specified in a control parameter and sets an upper limit on the chopper frequency. The current comparator can measure coil current during phases when the current flows through the sense resistor, but not during the slow decay phase, so the slow decay phase is terminated by a timer. The on phase is terminated by the comparator when the current through the coil reaches the target current. The fast decay phase may be terminated by either the comparator or another timer.

When the coil current is switched, spikes at the sense resistors occur due to charging and discharging parasitic capacitances. During this time, typically one or two microseconds, the current cannot be measured. Blanking is the time when the input to the comparator is masked to block these spikes.

There are two cycle-by-cycle chopper modes available: a new high-performance chopper algorithm called spreadCycle and a proven constant off-time chopper mode. The constant off-time mode cycles through three phases: on, fast decay, and slow decay. The spreadCycle mode cycles through four phases: on, slow decay, fast decay, and a second slow decay.

The chopper frequency is an important parameter for a chopped motor driver. A too low frequency might generate audible noise. A higher frequency reduces current ripple in the motor, but with a too high frequency magnetic losses may rise. Also power dissipation in the driver rises with increasing frequency due to the increased influence of switching slopes causing dynamic dissipation. Therefore, a compromise needs to be found. Most motors are optimally working in a frequency range of 16 kHz to 30 kHz. The chopper frequency is influenced by a number of parameter settings as well as by the motor inductivity and supply voltage.

Hint

A chopper frequency in the range of 16 kHz to 30 kHz gives a good result for most motors when using spreadCycle. A higher frequency leads to increased switching losses. It is advised to check the resulting frequency and to work below 50 kHz.

Three parameters are used for controlling both chopper modes:

Parameter	Description	Setting	Comment
<i>TOFF</i>	Sets the slow decay time (<i>off time</i>). This setting also limits the maximum chopper frequency. Setting this parameter to zero completely disables all driver transistors and the motor can free-wheel.	0	chopper off
		1...15	off time setting $N_{CLK} = 12 + 32 * TOFF$ (1 will work with minimum blank time of 24 clocks)
<i>TBL</i>	Selects the comparator <i>blank time</i> . This time needs to safely cover the switching event and the duration of the ringing on the sense resistor. For most applications, a setting of 1 or 2 is good. For highly capacitive loads, e.g. when filter networks are used, a setting of 2 or 3 will be required.	0	16 t_{CLK}
		1	24 t_{CLK}
		2	36 t_{CLK}
		3	54 t_{CLK}
<i>chm</i>	Selection of the <i>chopper mode</i>	0	spreadCycle
		1	classic const. off time

8.1 spreadCycle Chopper

The spreadCycle (patented) chopper algorithm is a precise and simple to use chopper mode which automatically determines the optimum length for the fast-decay phase. The spreadCycle will provide superior microstepping quality even with default settings. Several parameters are available to optimize the chopper to the application.

Each chopper cycle is comprised of an on phase, a slow decay phase, a fast decay phase and a second slow decay phase (see Figure 8.3). The two slow decay phases and the two blank times per chopper cycle put an upper limit to the chopper frequency. The slow decay phases typically make up for about 30%-70% of the chopper cycle in standstill and are important for low motor and driver power dissipation.

Calculation of a starting value for the slow decay time *TOFF*:

Assumptions:

Target Chopper frequency: 25kHz

Two slow decay cycles make up for 50% of overall chopper cycle time

$$t_{OFF} = \frac{1}{25kHz} * \frac{50}{100} * \frac{1}{2} = 10\mu s$$

For the *TOFF* setting this means:

$$TOFF = (t_{OFF} * f_{CLK} - 12)/32$$

With 12 MHz clock this gives a setting of *TOFF*=3.4, i.e. 3 or 4.

With 16 MHz clock this gives a setting of *TOFF*=4.6, i.e. 4 or 5.

The hysteresis start setting forces the driver to introduce a minimum amount of current ripple into the motor coils. The current ripple must be higher than the current ripple which is caused by resistive losses in the motor in order to give best microstepping results. This will allow the chopper to precisely regulate the current both for rising and for falling target current. The time required to introduce the current ripple into the motor coil also reduces the chopper frequency. Therefore, a higher hysteresis setting will lead to a lower chopper frequency. The motor inductance limits the ability of the chopper to follow a changing motor current. Further the duration of the on phase and the fast decay must be longer than the blanking time, because the current comparator is disabled during blanking.

It is easiest to find the best setting by starting from a low hysteresis setting (e.g. *HSTRT*=0, *HEND*=0) and increasing *HSTRT*, until the motor runs smoothly at low velocity settings. This can best be checked when measuring the motor current either with a current probe or by probing the sense resistor voltages (see Figure 8.2). Checking the sine wave shape near zero transition will show a small ledge between both half waves in case the hysteresis setting is too small. At medium velocities (i.e.

100 to 400 fullsteps per second), a too low hysteresis setting will lead to increased humming and vibration of the motor.

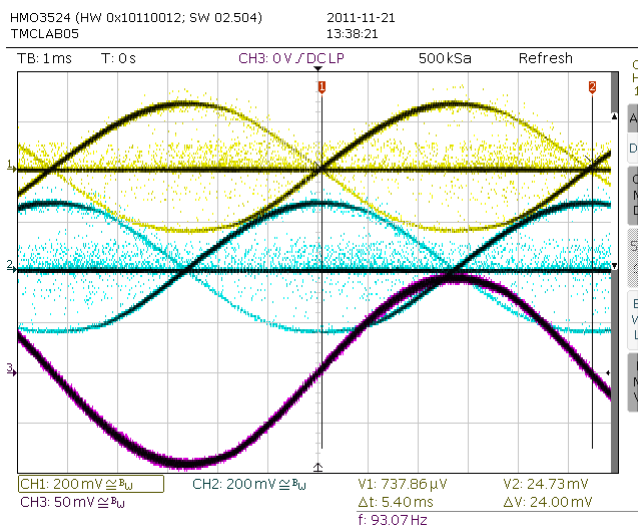

Figure 8.2 No ledges in current wave with sufficient hysteresis (magenta: current A, yellow & blue: sense resistor voltages A and B)

A too high hysteresis setting will lead to reduced chopper frequency and increased chopper noise but will not yield any benefit for the wave shape.

Quick Start

For a quick start, see the Quick Configuration Guide in chapter 13.

For detail procedure see Application Note AN001 - *Parameterization of spreadCycle*

As experiments show, the setting is quite independent of the motor, because higher current motors typically also have a lower coil resistance. Therefore choosing a low to medium default value for the hysteresis (for example, effective hysteresis = 4) normally fits most applications. The setting can be optimized by experimenting with the motor: A too low setting will result in reduced microstep accuracy, while a too high setting will lead to more chopper noise and motor power dissipation. When measuring the sense resistor voltage in motor standstill at a medium coil current with an oscilloscope, a too low setting shows a fast decay phase not longer than the blanking time. When the fast decay time becomes slightly longer than the blanking time, the setting is optimum. You can reduce the off-time setting, if this is hard to reach.

The hysteresis principle could in some cases lead to the chopper frequency becoming too low, e.g. when the coil resistance is high when compared to the supply voltage. This is avoided by splitting the hysteresis setting into a start setting (*HSTRT+HEND*) and an end setting (*HEND*). An automatic hysteresis decremter (*HDEC*) interpolates between both settings, by decrementing the hysteresis value stepwise each 16 system clocks. At the beginning of each chopper cycle, the hysteresis begins with a value which is the sum of the start and the end values (*HSTRT+HEND*), and decrements during the cycle, until either the chopper cycle ends or the hysteresis end value (*HEND*) is reached. This way, the chopper frequency is stabilized at high amplitudes and low supply voltage situations, if the frequency gets too low. This avoids the frequency reaching the audible range.

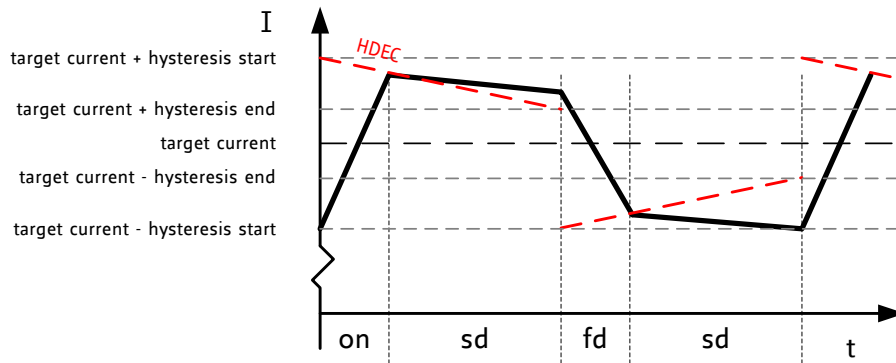

Figure 8.3 spreadCycle chopper scheme showing coil current during a chopper cycle

Two parameters control spreadCycle mode:

Parameter	Description	Setting	Comment
<i>HSTRT</i>	<i>Hysteresis start</i> setting. This value is an offset from the hysteresis end value <i>HEND</i> .	0...7	<i>HSTRT</i> =1...8 This value adds to <i>HEND</i> .
<i>HEND</i>	<i>Hysteresis end</i> setting. Sets the hysteresis end value after a number of decrements. The sum <i>HSTRT</i> + <i>HEND</i> must be ≤ 16 . At a current setting of max. 30 (amplitude reduced to 240), the sum is not limited.	0...2	-3...-1: negative <i>HEND</i>
		3	0: zero <i>HEND</i>
		4...15	1...12: positive <i>HEND</i>

Even at *HSTRT*=0 and *HEND*=0, the TMC2041 sets a minimum hysteresis via analog circuitry.

Example:

In the example a hysteresis of 4 has been chosen. You might decide to not use hysteresis decrement. In this case set:

HEND=6 (sets an effective end value of $6-3=3$)
HSTRT=0 (sets minimum hysteresis, i.e. $1: 3+1=4$)

In order to take advantage of the variable hysteresis, we can set most of the value to the *HSTRT*, i.e. 4, and the remaining 1 to hysteresis end. The resulting configuration register values are as follows:

HEND=0 (sets an effective end value of -3)
HSTRT=6 (sets an effective start value of hysteresis end +7: $7-3=4$)

Hint

Highest motor velocities sometimes benefit from setting *TOFF* to 1, 2 or 3 and a short *TBL* of 1 or 0.

8.2 Classic Constant Off Time Chopper

The classic constant off time chopper is an alternative to spreadCycle. Perfectly tuned, it also gives good results. Also, the classic constant off time chopper (automatically) is used in combination with fullstepping in dcStep operation.

The classic constant off-time chopper uses a fixed-time fast decay following each on phase. While the duration of the on-phase is determined by the chopper comparator, the fast decay time needs to be long enough for the driver to follow the falling slope of the sine wave, but it should not be so long that it causes excess motor current ripple and power dissipation. This can be tuned using an oscilloscope or evaluating motor smoothness at different velocities. A good starting value is a fast decay time setting similar to the slow decay time setting.

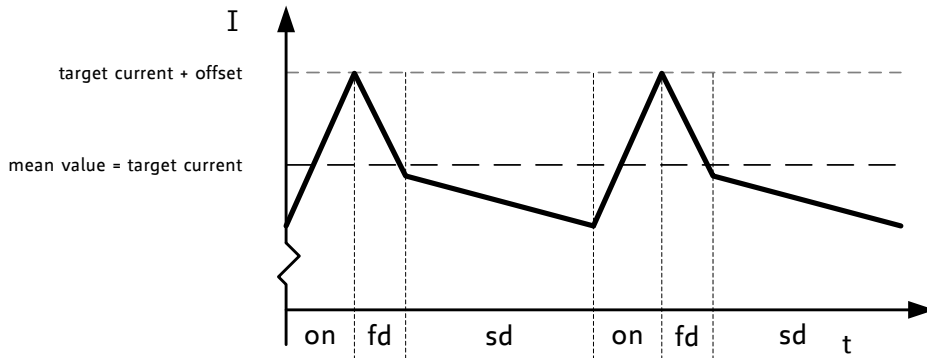

Figure 8.4 Classic const. off time chopper with offset showing coil current

After tuning the fast decay time, the offset should be tuned for a smooth zero crossing. This is necessary because the fast decay phase makes the absolute value of the motor current lower than the target current (see Figure 8.5). If the zero offset is too low, the motor stands still for a short moment during current zero crossing. If it is set too high, it makes a larger microstep. Typically, a positive offset setting is required for smoothest operation.

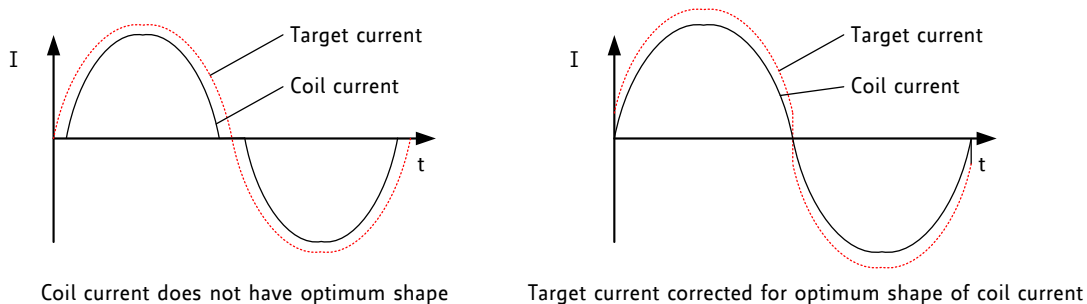

Figure 8.5 Zero crossing with classic chopper and correction using sine wave offset

Three parameters control constant off-time mode:

Parameter	Description	Setting	Comment
<i>TFD</i> (<i>fd3</i> & <i>HSTR1</i>)	<i>Fast decay time</i> setting. With <i>CHM</i> =1, these bits control the portion of fast decay for each chopper cycle.	0	slow decay only
		1...15	duration of fast decay phase
<i>OFFSET</i> (<i>HEND</i>)	<i>Sine wave offset</i> . With <i>CHM</i> =1, these bits control the sine wave offset. A positive offset corrects for zero crossing error.	0...2	negative offset: -3...-1
		3	no offset: 0
		4...15	positive offset 1...12
<i>disfdcc</i>	Selects usage of the <i>current comparator</i> for termination of the <i>fast decay</i> cycle. If current comparator is enabled, it terminates the fast decay cycle in case the current reaches a higher negative value than the actual positive value.	0	enable comparator termination of fast decay cycle
		1	end by time only

8.3 Random Off Time

In the constant off-time chopper mode, both coil choppers run freely without synchronization. The frequency of each chopper mainly depends on the coil current and the motor coil inductance. The inductance varies with the microstep position. With some motors, a slightly audible beat can occur between the chopper frequencies when they are close together. This typically occurs at a few microstep positions within each quarter wave. This effect is usually not audible when compared to mechanical noise generated by ball bearings, etc. Another factor which can cause a similar effect is a poor layout of the sense resistor GND connections.

Hint

A common factor, which can cause motor noise, is a bad PCB layout causing coupling of both sense resistor voltages (please refer layouts hint in chapter 19).

To minimize the effect of a beat between both chopper frequencies, an internal random generator is provided. It modulates the slow decay time setting when switched on by the *rndtf* bit. The *rndtf* feature further spreads the chopper spectrum, reducing electromagnetic emission on single frequencies.

Parameter	Description	Setting	Comment
<i>rndtf</i>	This bit switches on a <i>random off time</i> generator, which slightly modulates the off time <i>TOFF</i> using a random polynomial.	0	disable
		1	random modulation enable

9 Driver Diagnostic Flags

The TMC2041 drivers supply a complete set of diagnostic and protection capabilities, like short to GND protection and undervoltage detection. A detection of an open load condition allows testing if a motor coil connection is interrupted. See the *DRV_STATUS* table for details.

9.1 Temperature Measurement

The driver integrates a two level temperature sensor (120°C pre-warning and 150°C thermal shutdown) for diagnostics and for protection of the IC against excess heat. Heat is mainly generated by the motor driver stages, and, at increased voltage, by the internal voltage regulator. Most critical situations, where the driver MOSFETs could be overheated, are avoided when enabling the short to GND protection. For many applications, the overtemperature pre-warning will indicate an abnormal operation situation and can be used to initiate user warning or power reduction measures like motor current reduction. The thermal shutdown is just an emergency measure and temperature rising to the shutdown level should be prevented by design.

After triggering the overtemperature sensor (*ot* flag), the driver remains switched off until the system temperature falls below the pre-warning level (*otpw*) to avoid continuous heating to the shutdown level.

9.2 Short to GND Protection

The TMC2041 power stages are protected against a short circuit condition by an additional measurement of the current flowing through the high-side MOSFETs. This is important, as most short circuit conditions result from a motor cable insulation defect, e.g. when touching the conducting parts connected to the system ground. The short detection is protected against spurious triggering, e.g. by ESD discharges, by retrying three times before switching off the motor.

Once a short condition is safely detected, the corresponding driver bridge becomes switched off, and the *s2ga* or *s2gb* flag becomes set. In order to restart the motor, the user must intervene by disabling and re-enabling the driver. It should be noted, that the short to GND protection cannot protect the system and the power stages for all possible short events, as a short event is rather undefined and a complex network of external components may be involved. Therefore, short circuits should basically be avoided.

9.3 Open Load Diagnostics

Interrupted cables are a common cause for systems failing, e.g. when connectors are not firmly plugged. The TMC2041 detects open load conditions by checking, if it can reach the desired motor coil current. This way, also undervoltage conditions, high motor velocity settings or short and overtemperature conditions may cause triggering of the open load flag, and inform the user, that motor torque may suffer. In motor stand still, open load cannot be measured, as the coils might eventually have zero current.

In order to safely detect an interrupted coil connection, read out the open load flags at low or nominal motor velocity operation, only. However, the *ola* and *olb* flags have just informative character and do not cause any action of the driver.

10 stallGuard2 Load Measurement

stallGuard2 provides an accurate measurement of the load on the motor. It can be used for stall detection as well as other uses at loads below those which stall the motor, such as coolStep load-adaptive current reduction. The stallGuard2 measurement value changes linearly over a wide range of load, velocity, and current settings, as shown in Figure 10.1. At maximum motor load, the value goes to zero or near to zero. This corresponds to a load angle of 90° between the magnetic field of the coils and magnets in the rotor. This also is the most energy-efficient point of operation for the motor.

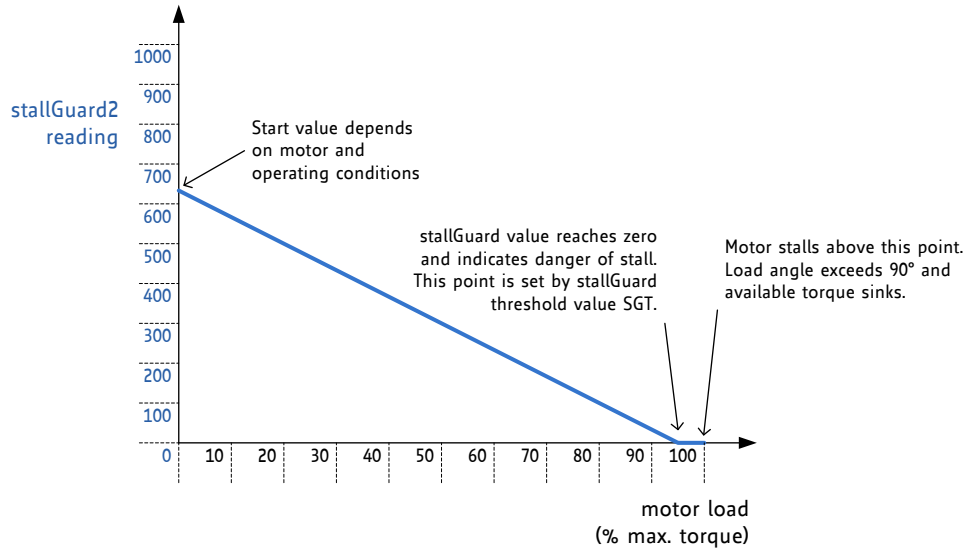

Figure 10.1 Function principle of stallGuard2

Parameter	Description	Setting	Comment
<i>SGT</i>	This signed value controls the stallGuard2 threshold level for stall detection and sets the optimum measurement range for readout. A lower value gives a higher sensitivity. Zero is the starting value working with most motors. A higher value makes stallGuard2 less sensitive and requires more torque to indicate a stall.	0	indifferent value
		+1... +63	less sensitivity
		-1... -64	higher sensitivity
<i>sfilt</i>	Enables the stallGuard2 filter for more precision of the measurement. If set, reduces the measurement frequency to one measurement per electrical period of the motor (4 fullsteps). Filtering should be switched off for pure stall detection.	0	standard mode
		1	filtered mode
Status word	Description	Range	Comment
<i>SG</i>	This is the <i>stallGuard2 result</i> . A higher reading indicates less mechanical load. A lower reading indicates a higher load and thus a higher load angle. Tune the <i>SGT</i> setting to show a <i>SG</i> reading of roughly 0 to 100 at maximum load before motor stall. To safely detect a stall, poll this value at least once per fullstep!	0... 1023	0: highest load low value: high load high value: less load

Attention

In order to use stallGuard2 and coolStep, the stallGuard2 sensitivity should first be tuned using the SGT setting!

10.1 Tuning stallGuard2 Threshold SGT

The stallGuard2 value SG is affected by motor-specific characteristics and application-specific demands on load and velocity. Therefore the easiest way to tune the stallGuard2 threshold SGT for a specific motor type and operating conditions is interactive tuning in the actual application.

INITIAL PROCEDURE FOR TUNING STALLGUARD SGT

1. Operate the motor at the normal operation velocity for your application and monitor SG .
2. Apply slowly increasing mechanical load to the motor. If the motor stalls before SG reaches zero, decrease SGT . If SG reaches zero before the motor stalls, increase SGT . A good SGT starting value is zero. SGT is signed, so it can have negative or positive values.
3. Now enable poll SG and check if it reaches zero. Polling should be done at least once per full step, i.e. with 1kHz polling rate a 200 step motor can be operated up to 5 RPS. Make sure, that the motor stall is safely detected at least once ($SG=0$) whenever it is stalled. Increase SGT if the motor becomes stopped before a stall occurs. Restart the motor by disabling sg_stop or by reading the $RAMP_STAT$ register (read and clear function).
4. The optimum setting is reached when SG is between 0 and roughly 100 at increasing load shortly before the motor stalls, and SG increases by 100 or more without load. SGT in most cases can be tuned for a certain motion velocity or a velocity range. Make sure, that the setting works reliable in a certain range (e.g. 80% to 120% of desired velocity) and also under extreme motor conditions (lowest and highest applicable temperature).

OPTIONAL PROCEDURE ALLOWING AUTOMATIC TUNING OF SGT

The basic idea behind the SGT setting is a factor, which compensates the stallGuard measurement for resistive losses inside the motor. At standstill and very low velocities, resistive losses are the main factor for the balance of energy in the motor, because mechanical power is zero or near to zero. This way, SGT can be set to an optimum at near zero velocity. This algorithm is especially useful for tuning SGT within the application to give the best result independent of environment conditions, motor stray, etc.

1. Operate the motor at low velocity < 10 RPM (i.e. a few to a few fullsteps per second) and target operation current and supply voltage. In this velocity range, there is not much dependence of SG on the motor load, because the motor does not generate significant back EMF. Therefore, mechanical load will not make a big difference on the result.
2. Switch on $sfilt$. Now increase SGT starting from 0 to a value, where SG starts rising. With a high SGT , SG will rise up to the maximum value. Reduce again to the highest value, where SG stays at 0. Now the SGT value is set as sensibly as possible. When you see SG increasing at higher velocities, there will be useful stall detection.

The upper velocity for the stall detection with this setting is determined by the velocity, where the motor back EMF approaches the supply voltage and the motor current starts dropping when further increasing velocity.

SG goes to zero for a time of one fullstep when the motor stalls. Evaluate SG only when the desired homing velocity is reached.

The system clock frequency affects SG . An external crystal-stabilized clock should be used for applications that demand the highest performance. The power supply voltage also affects SG , so tighter regulation results in more accurate values. SG measurement has a high resolution, and there are a few ways to enhance its accuracy, as described in the following sections.

Quick Start

For a quick start, see the Quick Configuration Guide in chapter 13.

For detail procedure see Application Note AN002 - *Parameterization of stallGuard2 & coolStep*

10.1.1 Variable Velocity Limits

The *SGT* setting chosen as a result of the previously described *SGT* tuning can be used for a certain velocity range. Outside this range, a stall may not be detected safely, and coolStep might not give the optimum result.

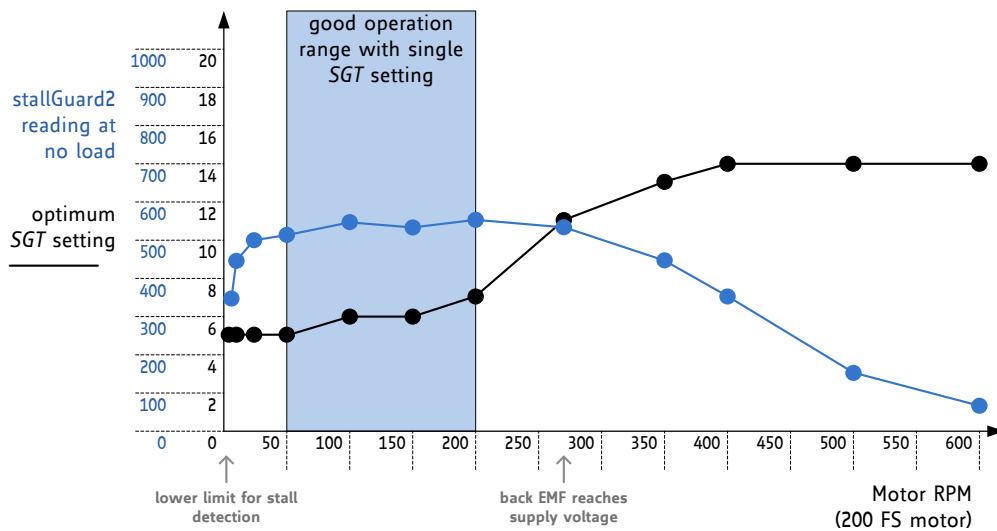

Figure 10.2 Example: Optimum *SGT* setting and stallGuard2 reading with an example motor

In many applications, operation at or near a single operation point is used most of the time and a single setting is sufficient.

In some applications, a velocity dependent tuning of the *SGT* value can be expedient, using a small number of support points and linear interpolation.

10.1.2 Small Motors with High Torque Ripple and Resonance

Motors with a high detent torque show an increased variation of the stallGuard2 measurement value *SG* with varying motor currents, especially at low currents. For these motors, the current dependency should be checked for best result.

10.1.3 Temperature Dependence of Motor Coil Resistance

Motors working over a wide temperature range may require temperature correction, because motor coil resistance increases with rising temperature. This can be corrected as a linear reduction of *SG* at increasing temperature, as motor efficiency is reduced.

10.1.4 Accuracy and Reproducibility of stallGuard2 Measurement

In a production environment, it may be desirable to use a fixed *SGT* value within an application for one motor type. Most of the unit-to-unit variation in stallGuard2 measurements results from manufacturing tolerances in motor construction. The measurement error of stallGuard2 – provided that all other parameters remain stable – can be as low as:

$$\text{stallGuard measurement error} = \pm \max(1, |SGT|)$$

10.2 stallGuard2 Update Rate and Filter

The stallGuard2 measurement value *SG* is updated with each full step of the motor. This is enough to safely detect a stall, because a stall always means the loss of four full steps. In a practical application, especially when using coolStep, a more precise measurement might be more important than an update for each fullstep because the mechanical load never changes instantaneously from one step to the next. For these applications, the *sfilt* bit enables a filtering function over four load measurements. The filter should always be enabled when high-precision measurement is required. It compensates for variations in motor construction, for example due to misalignment of the phase A to phase B magnets. The filter should be disabled when rapid response to increasing load is required and for best results of sensorless homing using stallGuard.

10.3 Detecting a Motor Stall

For best stall detection, work without stallGuard filtering (*sfilt=0*). To safely detect a motor stall the stall threshold must be determined using a specific *SGT* setting. Therefore, the maximum load needs to be determined, which the motor can drive without stalling. At the same time, monitor the *SG* value at this load, e.g. some value within the range 0 to 100. The stall threshold should be a value safely within the operating limits, to allow for parameter stray. The response at an *SGT* setting at or near 0 gives some idea on the quality of the signal: Check the *SG* value without load and with maximum load. They should show a difference of at least 100 or a few 100, which shall be large compared to the offset. If you set the *SGT* value in a way, that a reading of 0 occurs at maximum motor load, the stall can be automatically detected by the motion controller to issue a motor stop. In the moment of the step resulting in a step loss, the lowest reading will be visible. After the step loss, the motor will vibrate and show a higher *SG* reading.

10.4 Homing with stallGuard

The homing of a linear drive requires moving the motor into the direction of a hard stop. As stallGuard needs a certain velocity to work, make sure that the start point is far enough away from the hard stop to provide the distance required for the acceleration phase. After setting up *SGT*, start a motion into the direction of the hard stop and check *SG* for reaching 0.

10.5 Limits of stallGuard2 Operation

stallGuard2 does not operate reliably at extreme motor velocities: Very low motor velocities (for many motors, less than one revolution per second) generate a low back EMF and make the measurement unstable and dependent on environment conditions (temperature, etc.). The automatic tuning procedure described above will compensate for this. Other conditions will also lead to extreme settings of *SGT* and poor response of the measurement value *SG* to the motor load.

Very high motor velocities, in which the full sinusoidal current is not driven into the motor coils also leads to poor response. These velocities are typically characterized by the motor back EMF reaching the supply voltage.

11 coolStep Operation

coolStep is an automatic smart energy optimization for stepper motors based on the motor mechanical load, making them "green".

11.1 User Benefits



- Energy efficiency* - consumption decreased up to 75%
- Motor generates less heat* - improved mechanical precision
- Less cooling infrastructure* - for motor and driver
- Cheaper motor* - does the job!

coolStep allows substantial energy savings, especially for motors which see varying loads or operate at a high duty cycle. Because a stepper motor application needs to work with a torque reserve of 30% to 50%, even a constant-load application allows significant energy savings because coolStep automatically enables torque reserve when required. Reducing power consumption keeps the system cooler, increases motor life, and allows reducing cost in the power supply and cooling components.

Reducing motor current by half results in reducing power by a factor of four.

11.2 Setting up for coolStep

coolStep is controlled by several parameters, but two are critical for understanding how it works:

Parameter	Description	Range	Comment
<i>SEMIN</i>	4-bit unsigned integer that sets a <i>lower threshold</i> . If <i>SG</i> goes below this threshold, coolStep increases the current to both coils. The 4-bit <i>SEMIN</i> value is scaled by 32 to cover the lower half of the range of the 10-bit <i>SG</i> value. (The name of this parameter is derived from smartEnergy, which is an earlier name for coolStep.)	0	disable coolStep
		1...15	threshold is $SEMIN * 32$
<i>SEMAX</i>	4-bit unsigned integer that controls an <i>upper threshold</i> . If <i>SG</i> is sampled equal to or above this threshold enough times, coolStep decreases the current to both coils. The upper threshold is $(SEMIN + SEMAX + 1) * 32$.	0...15	threshold is $(SEMIN + SEMAX + 1) * 32$

Figure 11.1 shows the operating regions of coolStep:

- The black line represents the *SG* measurement value.
- The blue line represents the mechanical load applied to the motor.
- The red line represents the current into the motor coils.

When the load increases, *SG* falls below *SEMIN*, and coolStep increases the current. When the load decreases, *SG* rises above $(SEMIN + SEMAX + 1) * 32$, and the current is reduced.

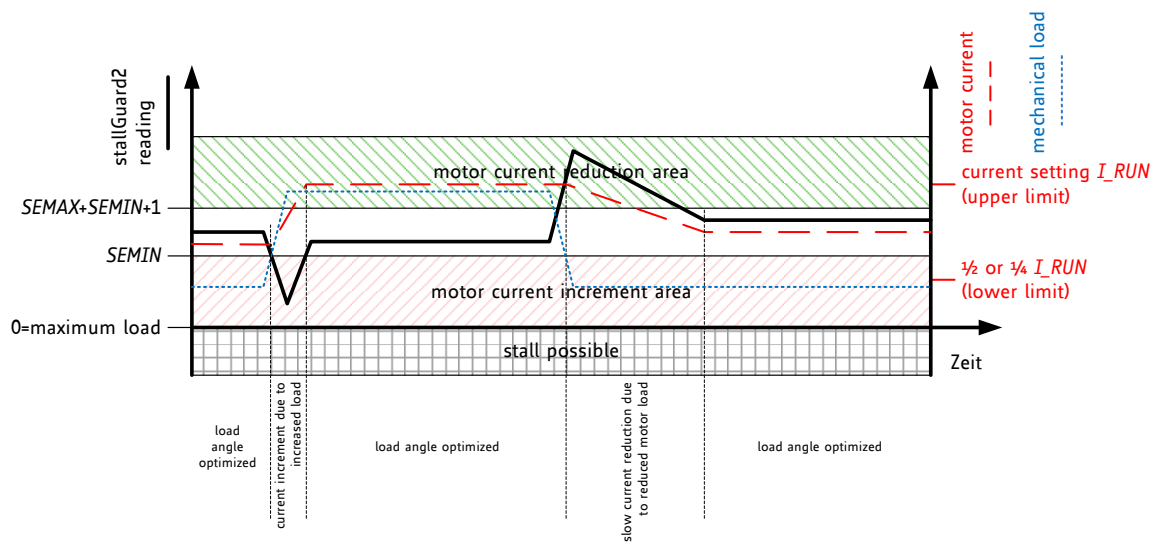

Figure 11.1 coolStep adapts motor current to the load

Five more parameters control coolStep and one status value is returned:

Parameter	Description	Range	Comment
<i>SEUP</i>	Sets the <i>current increment step</i> . The current becomes incremented for each measured stallGuard2 value below the lower threshold.	0...3	step width is 1, 2, 4, 8
<i>SEDN</i>	Sets the number of stallGuard2 readings above the upper threshold necessary for each <i>current decrement</i> of the motor current.	0...3	number of stallGuard2 measurements per decrement: 32, 8, 2, 1
<i>SEIMIN</i>	Sets the <i>lower motor current limit</i> for coolStep operation by scaling the <i>IRUN</i> current setting.	0 1	0: 1/2 of IRUN 1: 1/4 of IRUN
Status word	Description	Range	Comment
<i>CSACTIONAL</i>	This status value provides the <i>actual motor current scale</i> as controlled by coolStep. The value goes up to the <i>IRUN</i> value and down to the portion of <i>IRUN</i> as specified by <i>SEIMIN</i> .	0...31	1/32, 2/32, ... 32/32

11.3 Tuning coolStep

Before tuning coolStep, first tune the stallGuard2 threshold level *SGT*, which affects the range of the load measurement value *SG*. coolStep uses *SG* to operate the motor near the optimum load angle of +90°.

The current increment speed is specified in *SEUP*, and the current decrement speed is specified in *SEDN*. They can be tuned separately because they are triggered by different events that may need different responses. The encodings for these parameters allow the coil currents to be increased much more quickly than decreased, because crossing the lower threshold is a more serious event that may require a faster response. If the response is too slow, the motor may stall. In contrast, a slow response to crossing the upper threshold does not risk anything more serious than missing an opportunity to save power.

coolStep operates between limits controlled by the current scale parameter *IRUN* and the *seimin* bit.

11.3.1 Response Time

For fast response to increasing motor load, use a high current increment step *SEUP*. If the motor load changes slowly, a lower current increment step can be used to avoid motor oscillations. If the filter controlled by *sfilt* is enabled, the measurement rate and regulation speed are cut by a factor of four.

Hint

The most common and most beneficial use is to adapt coolStep for operation at the typical system target operation velocity and to set the velocity thresholds according. As acceleration and decelerations normally shall be quick, they will require the full motor current, while they have only a small contribution to overall power consumption due to their short duration.

11.3.2 Low Velocity and Standby Operation

Because coolStep is not able to measure the motor load in standstill and at very low RPM, a lower velocity threshold is provided in the ramp generator. It should be set to an application specific default value. Below this threshold the normal current setting via *IRUN* respectively *IHOLD* is valid. An upper threshold is provided by the *VHIGH* setting. Both thresholds can be set as a result of the stallGuard2 tuning process.

12 Step/Dir Interface

The STEP and DIR inputs provide a simple, standard interface compatible with many existing motion controllers. The microPlyer STEP pulse interpolator brings the smooth motor operation of high-resolution microstepping to applications originally designed for coarser stepping. The current settings are configured separately for motor run and standstill in register *IHOLD_IRUN*.

12.1 Timing

Figure 12.1 shows the timing parameters for the STEP and DIR signals, and the table below gives their specifications. When the DEDGE mode bit in the *DRVCTRL* register is set, both edges of STEP are active. If DEDGE is cleared, only rising edges are active. STEP and DIR are sampled and synchronized to the system clock. An internal analog filter removes glitches on the signals, such as those caused by long PCB traces. If the signal source is far from the chip, and especially if the signals are carried on cables, the signals should be filtered or differentially transmitted.

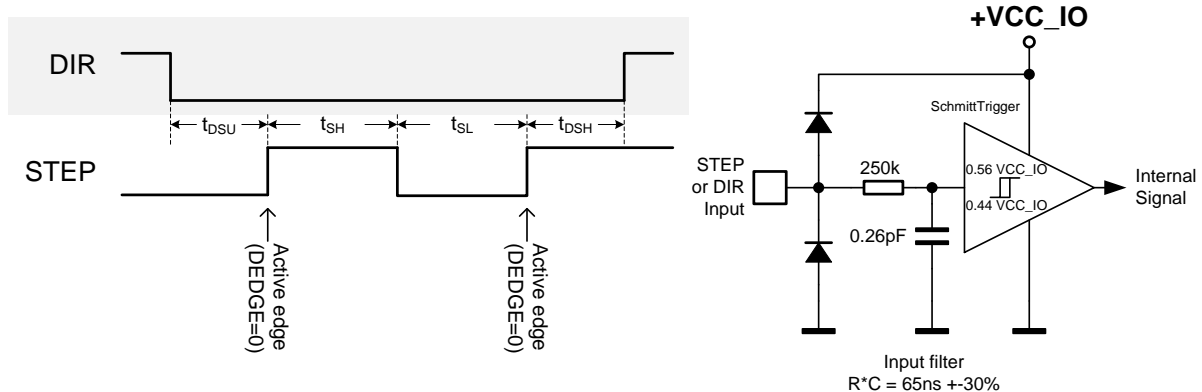

Figure 12.1 STEP and DIR timing, Input pin filter

STEP and DIR interface timing	AC-Characteristics clock period is t_{CLK}					
Parameter	Symbol	Conditions	Min	Typ	Max	Unit
step frequency (at maximum microstep resolution)	f_{STEP}	$dedge=0$			$\frac{1}{2} f_{CLK}$	
		$dedge=1$			$\frac{1}{4} f_{CLK}$	
fullstep frequency	f_{FS}				$f_{CLK}/512$	
STEP input low time *)	t_{SL}		$\max(t_{FILTSd}, t_{CLK}+20)$			ns
STEP input high time *)	t_{SH}		$\max(t_{FILTSd}, t_{CLK}+20)$			ns
DIR to STEP setup time	t_{DSU}		20			ns
DIR after STEP hold time	t_{DSH}		20			ns
STEP and DIR spike filtering time *)	t_{FILTSd}	rising and falling edge	36	60	85	ns
STEP and DIR sampling relative to rising CLK input	$t_{SDCLKHI}$	before rising edge of CLK input		t_{FILTSd}		ns

*) These values are valid with full input logic level swing, only. Asymmetric logic levels will increase filtering delay t_{FILTSd} , due to an internal input RC filter.

12.2 Changing Resolution

The TMC2041 allows operation in fullstep to 256 microsteps. Best performance is given with 16 microsteps and interpolation ($MRES=4$, $intpol16=1$), or in native 256 microstep mode ($MRES=0$). The internal microstep table uses 1024 sine wave entries to generate the wave. The step width taken within the table depends on the microstep resolution setting $MRES$. Depending on the DIR input, the microstep counter is increased ($DIR=0$) or decreased ($DIR=1$) with each STEP pulse by the step width. In principle, the microstep resolution can be changed at any time. The microstep resolution determines the increment respectively the decrement, the TMC2041 uses for advancing in the microstep table. At maximum resolution, it advances one step for each step pulse. At half resolution, it advances two steps and so on. This way, a change of resolution is possible transparently at each time.

12.2.1 Working with Half- and Fullstep Resolution

Fullstepping is desirable in some applications, where maximum torque at maximum velocity with a given motor is desired. Especially at low microstep resolutions like full- or halfstepping, the absolute current values and thus the absolute positions in the table are important for best motor performance. Thus, a software which uses resolution switching in order to get maximum torque and velocity from the drive, should switch the resolution at or near certain positions, as shown in the following table.

Step position	MSCNT value	current coil A	current coil B
half step 0	0	0%	100%
full step 0	128	70.7%	70.7%
half step 1	256	100%	0%
full step 1	384	70.7%	-70.7%
half step 2	512	0%	-100%
full step 2	640	-70.7%	-70.7%
half step 3	768	-100%	0%
full step 3	896	-70.7%	70.7%

Table 12.1 Optimum position sequence for half- and full stepping

When operating at less than 16 times microstepping, be sure to first position to a suitable, symmetric switching position, before changing $MRES$, otherwise the motor behavior may differ for left and right rotation. For 16 times microstepping, interpolation to 256 microsteps gives best results!

12.3 microPlyer Step Interpolator and Stand Still Detection

For each active edge on STEP, microPlyer produces 16 microsteps at 256x resolution, as shown in Figure 12.2.

Enable microPlyer by setting the $intpol16$ bit in the $CHOPCONF$ register. It only supports input at 16x setting, which becomes transformed into 256x resolution.

The step rate for the 16 microsteps is determined by measuring the time interval of the previous step period and dividing it into 16 equal parts. The maximum time between two microsteps corresponds to 2^{20} (roughly one million system clock cycles), for an even distribution of 256 microsteps. At 16 MHz system clock frequency, this results in a minimum step input frequency of 16 Hz for microPlyer operation (one fullstep per second). A lower step rate causes the $STST$ bit to be set, which indicates a standstill event. At that frequency, microsteps occur at a rate of $(\text{system clock frequency})/2^{16} - 256$ Hz. When a stand still is detected, the driver automatically switches the motor to holding current I_{HOLD} .

Attention

microPlyer only works well with a stable STEP frequency. Do not use the $dedge$ option if the STEP signal does not have a 50% duty cycle.

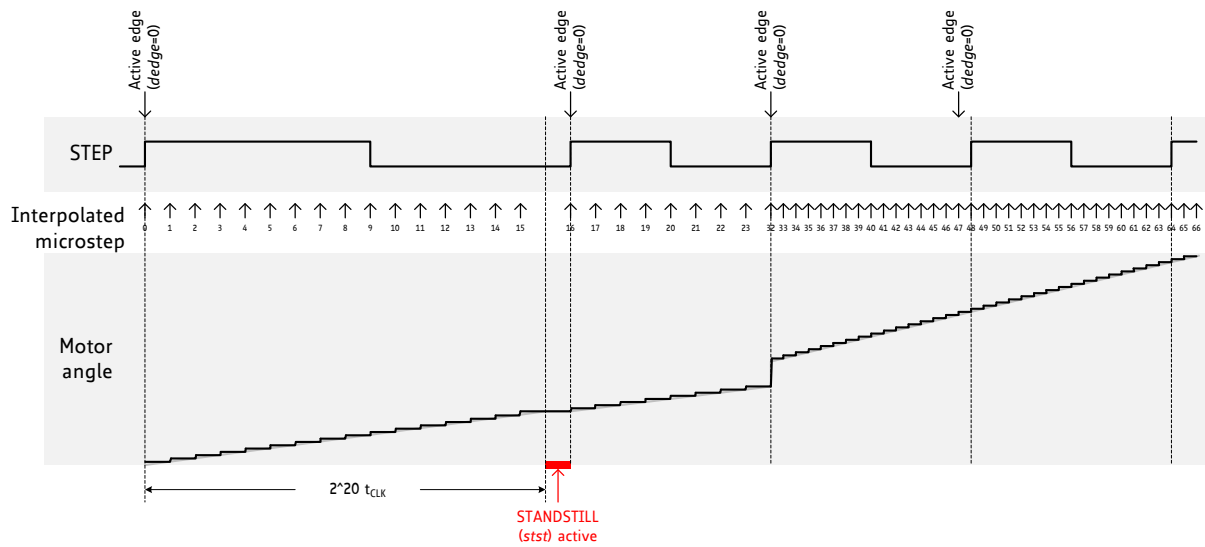

Figure 12.2 microPlyer microstep interpolation with rising STEP frequency

In Figure 12.2, the first STEP cycle is long enough to set the standstill bit *stst*. This bit is cleared on the next STEP active edge. Then, the external STEP frequency increases. After one cycle at the higher rate microPlyer adapts the interpolated microstep rate to the higher frequency. During the last cycle at the slower rate, microPlyer did not generate all 16 microsteps, so there is a small jump in motor angle between the first and second cycles at the higher rate.

13 Quick Configuration Guide

This guide is meant as a practical tool to come to a first configuration and do a minimum set of measurements and decisions for tuning the driver. It does not cover all advanced functionalities, but concentrates on the basic function set to make a motor run smoothly. Once the motor runs, you may decide to explore additional features, e.g. freewheeling and further functionality in more detail. A current probe on one motor coil is a good aid to find the best settings, but it is not a must.

CURRENT SETTING AND TUNING SPREADCYCLE

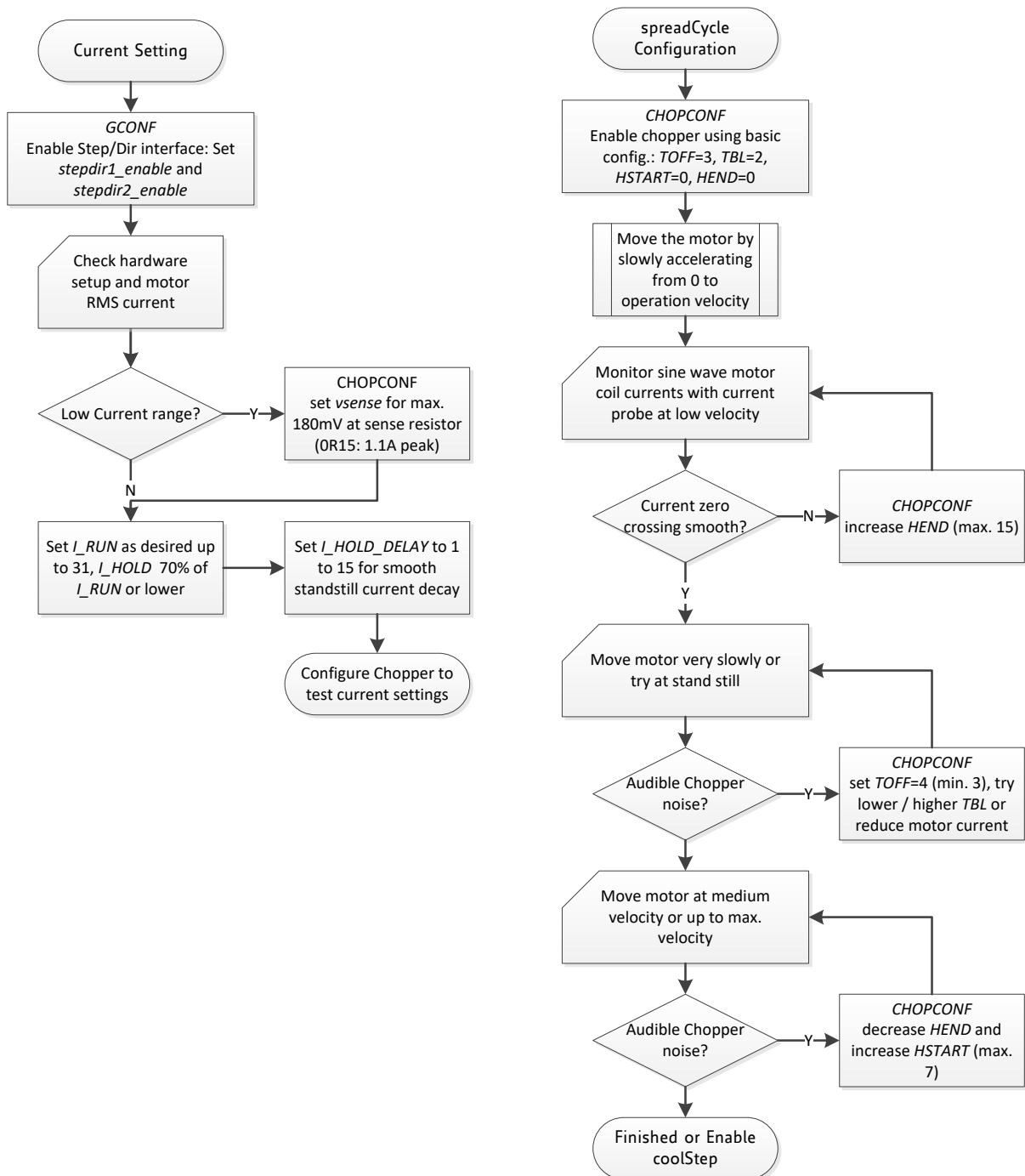

Figure 13.1 Current setting and configuration of spreadCycle

ENABLING COOLSTEP (ONLY IN COMBINATION WITH SPREADCYCLE)

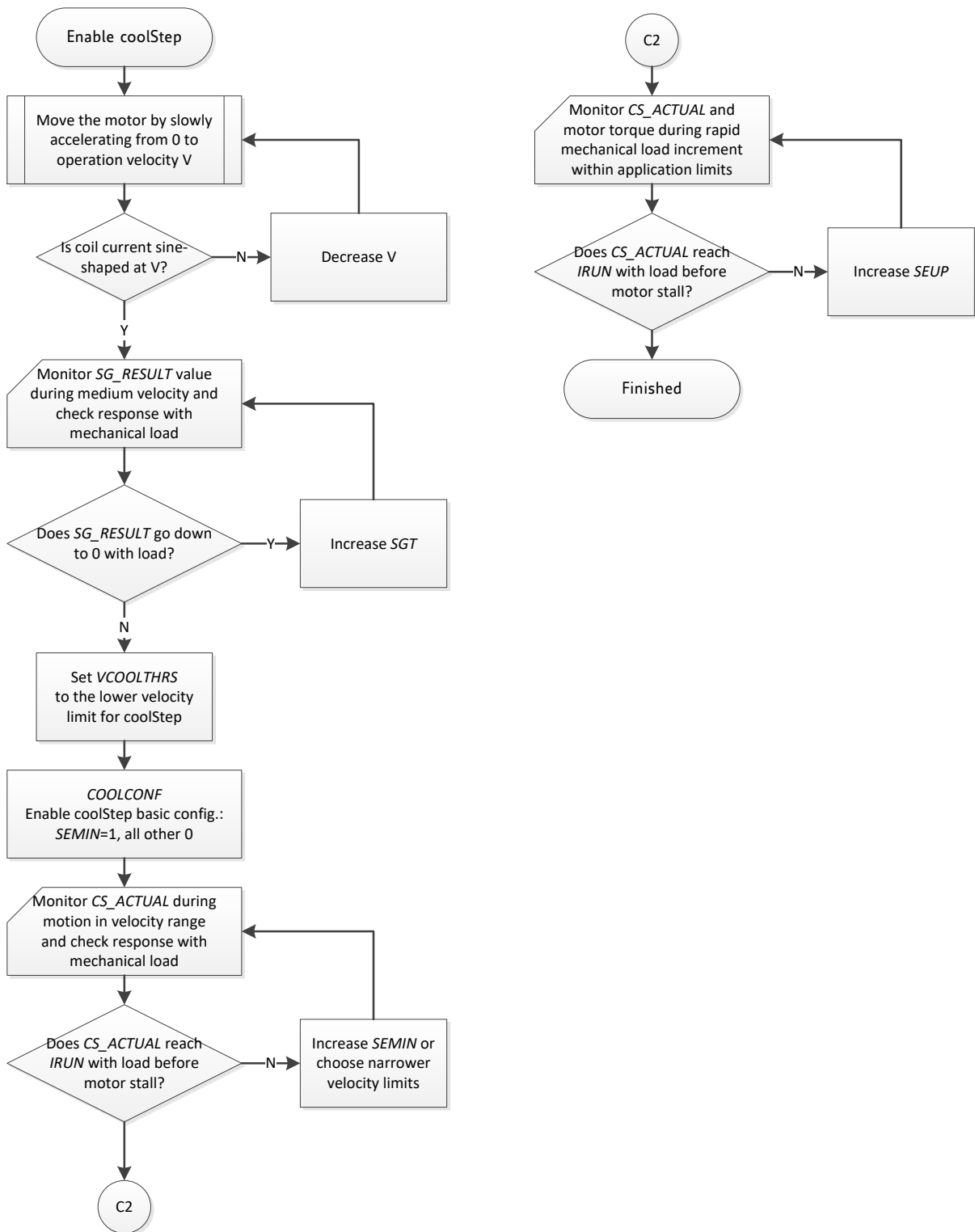

Figure 13.2 Enabling coolStep (only in combination with spreadCycle)

14 Getting Started

Please refer to the TMC2041 evaluation board to allow a quick start with the device, and in order to allow interactive tuning of the device setup in your application. Alternatively, all tuning can be done using a TMC5072 evaluation board, as the TMC5072 driver part is fully compatible. Chapter 13 will guide you through the process of correctly setting up all registers.

14.1 Initialization Examples

Initialization SPI datagram example sequence to enable driver 1 for step and direction operation and initialize the chopper for a 2 phase motor:

```
SPI send: 0x8000000006; // GCONF=6: Enable both drivers for step and direction operation
SPI send: 0xEC000100C3; // CHOPCONF: TOFF=3, HSTR=4, HEND=1, TBL=2, CHM=0 (spreadCycle)
SPI send: 0xB000061F05; // IHOLD_IRUN: IHOLD=5, IRUN=31 (max. current), IHOLDDELAY=6
```

For UART based operation it is important to make sure that the CRC byte is correct. The following example shows initialization for a TMC2041 with slave address 0 (NEXTADDR pin low). It programs driver 1 and driver 2 to spreadCycle mode:

```
UART write: 0x05 0x00 0x80 0x00 0x00 0x00 0x06 0x6E; // stepdir1=1, stepdir2=1
UART write: 0x05 0x00 0xEC 0x00 0x01 0x00 0xC5 0xD3; // DRV1: TOFF=5, HEND=1, HSTR=4,
// TBL=2, MRES=0, CHM=0
UART write: 0x05 0x00 0xB0 0x00 0x01 0x14 0x05 0xBB; // IHOLD=5, IRUN=20, IHOLDDELAY=1
UART write: 0x05 0x00 0xFC 0x00 0x01 0x00 0xC5 0x01; // DRV2: TOFF=5, HEND=1, HSTR=4,
// TBL=2, MRES=0, CHM=0
UART write: 0x05 0x00 0xD0 0x00 0x01 0x14 0x05 0xF0; // IHOLD=5, IRUN=20, IHOLDDELAY=1

UART read: 0x05 0x00 0x01 0xC1; // Request driver status GSTAT
```

Hint

Tune the configuration parameters for your motor and application for optimum performance. For generation of the UART data, use the CRC calculation tool from www.trinamic.com.

15 External Reset

The chip is loaded with default values during power on via its internal power-on reset. In order to reset the chip to power on defaults, any of the supply voltages monitored by internal reset circuitry (VSA, +5VOUT or VCC_IO) must be cycled. VCC is not monitored. Therefore VCC must not be switched off during operation of the chip. As +5VOUT is the output of the internal voltage regulator, it cannot be cycled via an external source except by cycling VSA. It is easiest and safest to cycle VCC_IO in order to completely reset the chip. Also, current consumed from VCC_IO is low and therefore it has simple driving requirements. Due to the input protection diodes not allowing the digital inputs to rise above VCC_IO level, all inputs must be driven low during this reset operation. When this is not possible, an input protection resistor may be used to limit current flowing into the related inputs.

In case, VCC becomes supplied by an external source, make sure that VCC is at a stable value above the lower operation limit once the reset ends. This normally is satisfied when generating a 3.3V VCC_IO from the +5V supply supplying the VCC pin, because it will then come up with a certain delay.

16 Clock Oscillator and Clock Input

The clock is the timing reference for the chopper operation. As the actual chopper frequency normally is less critical, the internal clock oscillator can be used for most cases.

16.1 Using the Internal Clock

Directly tie the CLK input to GND near to the TMC2041 if the internal clock oscillator is to be used. The temperature dependency and ageing of the internal clock is comparatively low.

Hint

In case precise motor chopper operation and best stability of stallGuard are desired, it is supposed to work with an external clock source.

16.2 Using an External Clock

When an external clock is available, a frequency of 10MHz to 16MHz is recommended for optimum performance. The duty cycle of the clock signal is uncritical, as long as minimum high or low input time for the pin is satisfied (refer to electrical characteristics). Up to 18 MHz can be used, when the clock duty cycle is 50%. Make sure, that the clock source supplies clean CMOS output logic levels and steep slopes when using a high clock frequency. The external clock input is enabled with the first positive polarity seen on the CLK input.

Attention

Switching off the external clock frequency prevents the driver from operating normally. Therefore be careful to switch off the motor drivers before switching off the clock (e.g. using the enable input), because otherwise the chopper would stop and the motor current level could rise uncontrolled. The short to GND detection stays active even without clock, if enabled.

16.3 Considerations on the Frequency

A higher frequency allows faster step rates, faster SPI operation and higher chopper frequencies. On the other hand, it may cause more electromagnetic emission of the system and causes more power dissipation in the TMC2041 digital core and voltage regulator. Generally a frequency of 10 MHz to 16 MHz should be sufficient for most applications. For reduced requirements concerning the motor dynamics, a clock frequency of down to 8 MHz can be considered.

17 Absolute Maximum Ratings

The maximum ratings may not be exceeded under any circumstances. Operating the circuit at or near more than one maximum rating at a time for extended periods shall be avoided by application design.

Parameter	Symbol	Min	Max	Unit
Supply voltage operating with inductive load ($V_{VS} \geq V_{VSA}$)	V_{VS}, V_{VSA}	-0.5	27	V
Supply and bridge voltage max. *)	V_{VS}	-0.5	28	V
VSA when different from to VS	V_{VSA}	-0.5	$V_{VS}+0.5$	V
I/O supply voltage	V_{VIO}	-0.5	5.5	V
digital VCC supply voltage (if not supplied by internal regulator)	V_{VCC}	-0.5	5.5	V
Logic input voltage	V_I	-0.5	$V_{VIO}+0.5$	V
Maximum current to / from digital pins and analog low voltage I/Os	I_{IO}		+/-10	mA
5V regulator output current (internal plus external load)	I_{5VOUT}		50	mA
5V regulator continuous power dissipation ($(V_{VM}-5V) * I_{5VOUT}$)	P_{5VOUT}		1	W
Power bridge repetitive output current	I_{Ox}		2.0	A
Junction temperature	T_J	-50	150	°C
Storage temperature	T_{STG}	-55	150	°C
ESD-Protection for interface pins (Human body model, HBM)	V_{ESDAP}		4 (tbd.)	kV
ESD-Protection for handling (Human body model, HBM)	V_{ESD}		1 (tbd.)	kV

*) Stray inductivity of GND and VS connections will lead to ringing of the supply voltage when driving an inductive load. This ringing results from the fast switching slopes of the driver outputs in combination with reverse recovery of the body diodes of the output driver MOSFETs. Even small trace inductivities as well as stray inductivity of sense resistors can easily generate a few volts of ringing leading to temporary voltage overshoot. This should be considered when working near the maximum voltage.

18 Electrical Characteristics

18.1 Operational Range

Parameter	Symbol	Min	Max	Unit
Junction temperature	T_J	-40	125	°C
Supply voltage (using internal +5V regulator)	V_{VS}	5.5	26	V
Supply voltage (internal +5V regulator bridged: $V_{VCC}=V_{VSA}$)	V_{VS}	4.7	5.4	V
I/O supply voltage	V_{VIO}	3.00	5.25	V
VCC voltage when using optional external source (supplies digital logic and charge pump)	V_{VCC}	4.6	5.25	V
RMS motor coil current per coil (value for design guideline)	I_{RMS}		0.8	A
Peak output current per motor coil output (sine wave peak)	I_{Ox}		1.1	A
Peak output current per motor coil output (sine wave peak) Limit $T_J \leq 105^\circ\text{C}$, e.g. for 100ms short time acceleration phase below 50% duty cycle.	I_{Ox}		1.5	A

18.2 DC Characteristics and Timing Characteristics

DC characteristics contain the spread of values guaranteed within the specified supply voltage range unless otherwise specified. Typical values represent the average value of all parts measured at +25°C. Temperature variation also causes stray to some values. A device with typical values will not leave Min/Max range within the full temperature range.

Power supply current		DC-Characteristics				
		$V_{VS} = 24.0V$				
Parameter	Symbol	Conditions	Min	Typ	Max	Unit
Total supply current, driver disabled $I_{VS} + I_{VSA} + I_{VCC}$	I_S	$f_{CLK}=16MHz$		25	40	mA
Total supply current, operating, $I_{VS} + I_{VSA} + I_{VCC}$	I_S	$f_{CLK}=16MHz, 40kHz$ chopper		28		mA
Static supply current	I_{VS0}	$f_{CLK}=0Hz$	3	4.5	7	mA
Supply current, driver disabled, dependency on CLK frequency	I_{VSX}	f_{CLK} variable, additional to I_{VS0}		1.3		mA/MHz
Internal current consumption from 5V supply on VCC pin	I_{VCC}	$f_{CLK}=16MHz, 40kHz$ chopper		25	40	mA
IO supply current	I_{VIO}	no load on outputs, inputs at V_{IO} or GND		15	30	μA

Motor driver section		DC- and Timing-Characteristics				
		$V_{VS} = 24.0V$				
Parameter	Symbol	Conditions	Min	Typ	Max	Unit
RDS _{ON} lowside MOSFET	R_{ONL}	measure at 100mA, 25°C, static state		0.4	0.5	Ω
RDS _{ON} highside MOSFET	R_{ONH}	measure at 100mA, 25°C, static state		0.5	0.6	Ω
slope, MOSFET turning on	t_{SLPON}	measured at 700mA load current	50	120	250	ns
slope, MOSFET turning off	t_{SLPOFF}	measured at 700mA load current	50	220	450	ns
Current sourcing, driver off	I_{IDLE}	O_{XX} pulled to GND	120	180	250	μA

Charge pump		DC-Characteristics				
Parameter	Symbol	Conditions	Min	Typ	Max	Unit
Charge pump output voltage	$V_{VCP}-V_{VS}$	operating, typical $f_{chop}<40kHz$	4.0	$V_{SVOUT} - 0.4$	V_{SVOUT}	V
Charge pump voltage threshold for undervoltage detection	$V_{VCP}-V_{VS}$	using internal 5V regulator voltage	3.1	3.6	3.9	V
Charge pump frequency	f_{CP}			1/16 f_{CLKOSC}		

Linear regulator		DC-Characteristics				
Parameter	Symbol	Conditions	Min	Typ	Max	Unit
Output voltage	V_{SVOUT}	$I_{SVOUT} = 0mA$ $T_J = 25^\circ C$	4.75	5.0	5.25	V
Output resistance	R_{SVOUT}	Static load		3		Ω
Deviation of output voltage over the full temperature range	$V_{SVOUT(DEV)}$	$I_{SVOUT} = 30mA$ $T_J = \text{full range}$		30	100	mV

Clock oscillator and input	Timing-Characteristics					
Parameter	Symbol	Conditions	Min	Typ	Max	Unit
Clock oscillator frequency	f_{CLKOSC}	$t_j = -50^\circ C$	9	12.4		MHz
Clock oscillator frequency	f_{CLKOSC}	$t_j = 50^\circ C$	10.1	13.2	17.2	MHz
Clock oscillator frequency	f_{CLKOSC}	$t_j = 150^\circ C$		13.4	18	MHz
External clock frequency (operating)	f_{CLK}		4	10-16	18	MHz
External clock high / low level time	t_{CLKL} / t_{CLKH}	CLK driven to $0.1 V_{VIO} / 0.9 V_{VIO}$	10			ns
External clock first cycle triggering switching to external clock source	t_{CLK1}	CLK driven high	30	25		ns

Detector levels	DC-Characteristics					
Parameter	Symbol	Conditions	Min	Typ	Max	Unit
V_{VSA} undervoltage threshold for RESET	V_{UV_VSA}	V_{VS} rising	3.8	4.2	4.6	V
V_{5VOUT} undervoltage threshold for RESET	V_{UV_5VOUT}	V_{5VOUT} rising		3.5		V
V_{VCC_IO} undervoltage threshold for RESET	V_{UV_VIO}	V_{VCC_IO} rising	1.9	2.55	3.0	V
V_{VCC_IO} undervoltage detector hysteresis	$V_{UV_VIOHYST}$		0.1	0.3	0.5	V
Short to GND detector threshold ($V_{VSP} - V_{Ox}$)	V_{OS2G}		1.5	2.2	3	V
Short to GND detector delay (high side switch on to short detected)	t_{S2G}	High side output clamped to $V_{SP}-3V$	0.8	1.3	2	μs
Overtemperature prewarning	t_{OTPW}	Temperature rising	100	120	140	$^\circ C$
Overtemperature shutdown	t_{OT}	Temperature rising	135	150	170	$^\circ C$

Sense resistor voltage levels	DC-Characteristics					
Parameter	Symbol	Conditions	Min	Typ	Max	Unit
Sense input peak threshold voltage (low sensitivity)	V_{SRTL}	$vsense=0$ $csactual=31$ $sin_x=248$ $Hyst.=0; I_{BRxy}=0$		320		mV
sense input peak threshold voltage (high sensitivity)	V_{SRTH}	$vsense=1$ $csactual=31$ $sin_x=248$ $Hyst.=0; I_{BRxy}=0$		180		mV
Sense input tolerance / motor current full scale tolerance	I_{COIL}	$vsense=0$	-5		+5	%
Internal resistance from pin BRxy to internal sense comparator (additional to sense resistor)	R_{BRxy}			20		m Ω

Digital logic levels	DC-Characteristics					
Parameter	Symbol	Conditions	Min	Typ	Max	Unit
Input voltage low level	V_{INLO}		-0.3		$0.3 V_{VIO}$	V
Input voltage high level	V_{INHI}		$0.7 V_{VIO}$		$V_{VIO}+0.3$	V
Input Schmitt trigger hysteresis	V_{INHYST}			$0.12 V_{VIO}$		V
Output voltage low level	V_{OUTLO}	$I_{OUTLO} = 2mA$			0.2	V
Output voltage high level	V_{OUTH}	$I_{OUTH} = -2mA$	$V_{VIO}-0.2$			V
Input leakage current	I_{ILEAK}		-10		10	μA
Digital pin capacitance	C			3.5		pF

18.3 Thermal Characteristics

The following table shall give an idea on the thermal resistance of the QFN-48 package. The thermal resistance for a four layer board will provide a good idea on a typical application. The single layer board example is kind of a worst case condition, as the typical application will require a 4 layer board. Actual thermal characteristics will depend on the PCB layout, PCB type and PCB size.

A thermal resistance of 23°C/W for a typical board means, that the package is capable of continuously dissipating 4W at an ambient temperature of 25°C with the die temperature staying below 125°C.

Parameter	Symbol	Conditions	Typ	Unit
Typical power dissipation One motor active, one motor in standby at low current	P_D	One motor 1.00A RMS 115°C (125°C)	3.7	W
		One motor 0.71A RMS 85°C (93°C)	2.4	W
		Surface temperature at package center (peak surface temperature), board 55mm x 85mm, 25°C environment spreadCycle, sinewave, 40 or 20kHz chopper, 24V, 16MHz, internal supply for VCC Motors: QSH4218-035-10-027		
Typical power dissipation Two motors active	P_D	Two motors 0.71A RMS 113°C (119°C)	3.7	W
		Two motors 0.35A RMS 64°C (68°C)	1.4	W
Thermal resistance junction to ambient on a single layer board	R_{TJA}	Single signal layer board (1s) as defined in JEDEC EIA JESD51-3 (FR4, 76.2mm x 114.3mm, d=1.6mm)	80	K/W
Thermal resistance junction to ambient on a multilayer board	R_{TMJA}	Dual signal and two internal power plane board (2s2p) as defined in JEDEC EIA JESD51-5 and JESD51-7 (FR4, 76.2mm x 114.3mm, d=1.6mm)	23	K/W
Thermal resistance junction to ambient on a multilayer board with air flow	R_{TMJA1}	Identical to R_{TMJA} , but with air flow 1m/s	20	K/W
Thermal resistance junction to board	R_{TJB}	PCB temperature measured within 1mm distance to the package	10	K/W
Thermal resistance junction to case	R_{TJC}	Junction temperature to heat slug of package	3	K/W

The thermal resistance in an actual layout can be tested by checking for the heat up caused by the standby power consumption of the chip. When no motor is attached, all power seen on the power supply is dissipated within the chip.

Note

A spread-sheet for calculating TMC2041 power dissipation is available on www.trinamic.com.

19 Layout Considerations

19.1 Exposed Die Pad

The TMC2041 uses its die attach pad to dissipate heat from the drivers and the linear regulator to the board. For best electrical and thermal performance, use a reasonable amount of solid, thermally conducting vias between the die attach pad and the ground plane. The printed circuit board should have a solid ground plane spreading heat into the board and providing for a stable GND reference.

19.2 Wiring GND

All signals of the TMC2041 are referenced to their respective GND. Directly connect all GND pins under the TMC2041 to a common ground area (GND, GNDP, GNDA and die attach pad). The GND plane right below the die attach pad should be treated as a virtual star point. For thermal reasons, the PCB top layer shall be connected to a large PCB GND plane spreading heat within the PCB.

Attention

Especially, the sense resistors are susceptible to GND differences and GND ripple voltage, as the microstep current steps make up for voltages down to 0.5 mV. No current other than the sense resistor current should flow on their connections to GND and to the TMC2041. Optimally place them close to the TMC2041, with one or more vias to the GND plane for each sense resistor. The two sense resistors for one coil should not share a common ground connection trace or vias, as also PCB traces have a certain resistance.

19.3 Supply Filtering

The 5VOUT output voltage ceramic filtering capacitor (4.7 μ F recommended) should be placed as close as possible to the 5VOUT pin, with its GND return going directly to the GNDA pin. Use as short and as thick connections as possible. For best microstepping performance and lowest chopper noise an additional filtering capacitor can be used for the VCC pin to GND, to avoid charge pump and digital part ripple influencing motor current regulation. Therefore place a ceramic filtering capacitor (470nF recommended) as close as possible (1-2mm distance) to the VCC pin with GND return going to the ground plane. VCC can be coupled to 5VOUT using a 2.2 Ω resistor in order to supply the digital logic from 5VOUT while keeping ripple away from this pin.

A 100 nF filtering capacitor should be placed as close as possible to the VSA pin to ground plane. The motor supply pins VS should be decoupled with an electrolytic capacitor (47 μ F or larger is recommended) and a ceramic capacitor, placed close to the device.

Take into account that the switching motor coil outputs have a high dV/dt . Thus capacitive stray into high resistive signals can occur, if the motor traces are near other traces over longer distances.

19.4 Single Driver Connection

In a parallel connection setup, where the TMC2041 drives one motor with double current, take into account, that driver 1 takes over the complete control. Thus, the driver 1 layout should be optimized concerning sense resistor placement, etc. Connect driver 2 bridge outputs and BR pins in parallel to the corresponding driver 1 pins. Especially for the BR pins of driver 2, it is important to use low inductivity interconnection lines to driver 1.

19.5 Layout Example

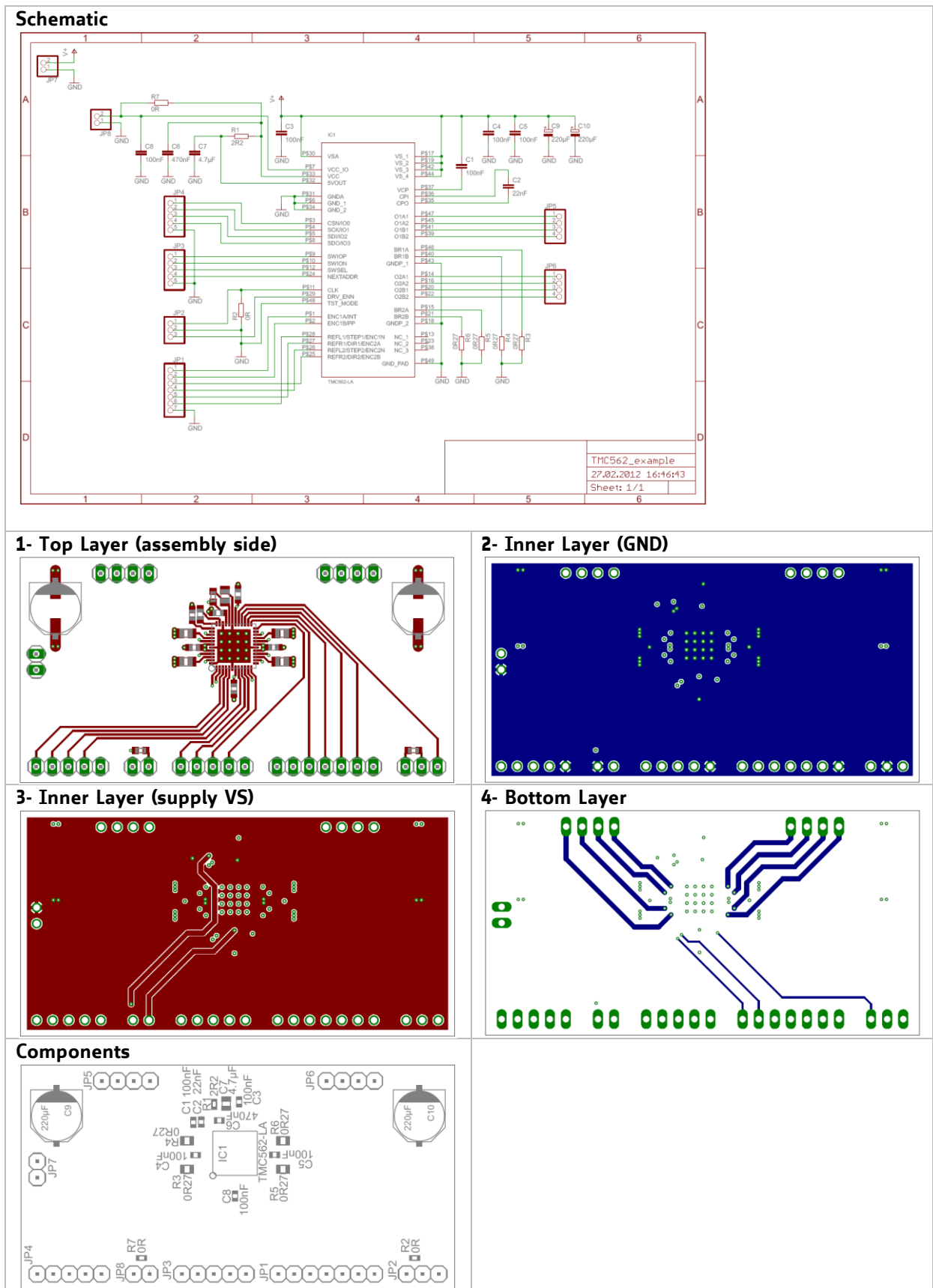

Figure 19.1 Layout example

20 Package Mechanical Data

20.1 Dimensional Drawings

Attention: Drawings not to scale.

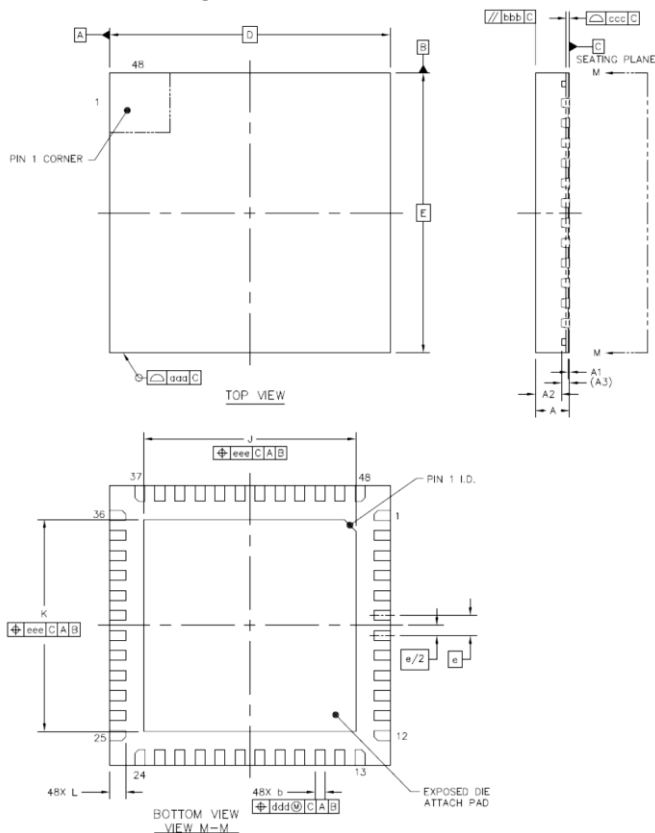

Figure 20.1 Dimensional drawings

Parameter	[mm]	Ref	Min	Nom	Max
total thickness		A	0.80	0.85	0.90
stand off		A1	0.00	0.035	0.05
mold thickness		A2	-	0.65	0.67
lead frame thickness		A3		0.203	
lead width		b	0.2	0.25	0.3
body size X		D		7.0	
body size Y		E		7.0	
lead pitch		e		0.5	
exposed die pad size X		J	5.2	5.3	5.4
exposed die pad size Y		K	5.2	5.3	5.4
lead length		L	0.35	0.4	0.45
package edge tolerance		aaa			0.1
mold flatness		bbb			0.1
coplanarity		ccc			0.08
lead offset		ddd			0.1
exposed pad offset		eee			0.1

20.2 Package Codes

Type	Package	Temperature range	Code & marking
TMC2041-LA	QFN48 (RoHS)	-40°C ... +125°C	TMC2041-LA

21 Disclaimer

TRINAMIC Motion Control GmbH & Co. KG does not authorize or warrant any of its products for use in life support systems, without the specific written consent of TRINAMIC Motion Control GmbH & Co. KG. Life support systems are equipment intended to support or sustain life, and whose failure to perform, when properly used in accordance with instructions provided, can be reasonably expected to result in personal injury or death.

Information given in this data sheet is believed to be accurate and reliable. However no responsibility is assumed for the consequences of its use nor for any infringement of patents or other rights of third parties which may result from its use.

Specifications are subject to change without notice.

All trademarks used are property of their respective owners.

22 ESD Sensitive Device

The TMC2041 is an ESD sensitive CMOS device sensitive to electrostatic discharge. Take special care to use adequate grounding of personnel and machines in manual handling. After soldering the devices to the board, ESD requirements are more relaxed. Failure to do so can result in defect or decreased reliability.



23 Table of Figures

Figure 1.1 Basic application and block diagram.....	4
Figure 1.2 Energy efficiency with coolStep (example).....	6
Figure 2.1 TMC2041 pin assignments.....	7
Figure 3.1 Standard application circuit.....	10
Figure 3.2 5V only operation.....	11
Figure 3.3 Driving a single motor with high current.....	12
Figure 3.4 Using an external 5V supply to bypass internal regulator	13
Figure 3.5 RC-Filter on VCC for reduced ripple	13
Figure 3.6 Simple ESD enhancement and more elaborate motor output protection	14
Figure 4.1 SPI timing.....	17
Figure 5.1 Addressing multiple TMC2041 via single wire interface using chaining	21
Figure 5.2 Addressing multiple TMC2041 via differential interface, additional filtering for NEXTADDR ...	22
Figure 8.1 Chopper phases	34
Figure 8.2 No ledges in current wave with sufficient hysteresis (magenta: current A, yellow & blue: sense resistor voltages A and B)	36
Figure 8.3 spreadCycle chopper scheme showing coil current during a chopper cycle	37
Figure 8.4 Classic const. off time chopper with offset showing coil current.....	38
Figure 8.5 Zero crossing with classic chopper and correction using sine wave offset.....	38
Figure 10.1 Function principle of stallGuard2	41
Figure 10.2 Example: Optimum SGT setting and stallGuard2 reading with an example motor	43
Figure 11.1 coolStep adapts motor current to the load	46
Figure 12.1 STEP and DIR timing, Input pin filter	48
Figure 12.2 microPlyer microstep interpolation with rising STEP frequency.....	50
Figure 13.1 Current setting and configuration of spreadCycle.....	51
Figure 13.3 Enabling coolStep (only in combination with spreadCycle).....	52
Figure 19.1 Layout example	61
Figure 20.1 Dimensional drawings	62

24 Revision History

Version	Date	Author BD – Bernhard Dwersteg	Description
0.90	2016-NOV-23	BD	First version based on TMC5072 datasheet
1.00	2016-NOV-25	BD	Complete version
1.02	2017-MAY-16	BD	Minor corrections

Table 24.1 Documentation revisions

25 References

[TMC2041-EVAL] TMC2041-EVAL Manual

[AN001] Trinamic Application Note 001 - Parameterization of spreadCycle™, www.trinamic.com

[AN002] Trinamic Application Note 002 - Parameterization of stallGuard2™ & coolStep™,
www.trinamic.com

Calculation sheet [TMC50XX Calculations.xlsx](#)

Mouser Electronics

Authorized Distributor

Click to View Pricing, Inventory, Delivery & Lifecycle Information:

[Analog Devices Inc.:](#)

[TMC2041-LA-T](#) [TMC2041-EVAL](#) [TMC2041-EVAL-KIT](#) [TMC2041-LA](#)