

PVL SERIES PILOT INDICATOR

- ANTI-VANDAL SWITCHES
- DETECTOR SWITCHES
- DIP SWITCHES
- KEYLOCK SWITCHES
- NAVIGATION SWITCHES
- PUSHBUTTON SWITCHES
- ROCKER SWITCHES
- ROTARY SWITCHES
- SLIDE SWITCHES
- SNAP ACTION SWITCHES
- TACTILE SWITCHES
- TOGGLE SWITCHES
- CAP OPTIONS

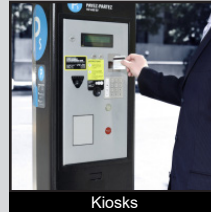

APPLICATIONS / MARKETS



RoHS

SPECIFICATIONS

Contact Arrangement: Lamp indicator
Operating/Storage Temperature: -25°C to 55°C
Lamp Life: 40,000 Hours Nominal
Ingress Protection: IP67
Panel Thickness: 1-6mm or 1-10mm, (depending on mounting diameter)
Mounting Nut Torque: 5-14Nm

FEATURES & BENEFITS

- Pilot indicator light
- Multiple panel cutout sizes -- 6mm to 19mm dia.
- Multiple illumination voltage options
- Multiple LED color options
- Wire leads (150mm long) optional
- IP67 rated

PART NUMBER CONFIGURATOR

Series	Panel Cutout Diameter	Lens	Terminal	Body Finish	Lens Color	Illumination Voltage
<input type="text" value="PVL"/>	<input type="text" value="06"/> <input type="text" value="08"/> <input type="text" value="10"/> <input type="text" value="12"/> <input type="text" value="14"/> <input type="text" value="16"/> <input type="text" value="19"/>	<input type="text" value="F"/> <input type="text" value="R"/>	<input type="text" value="L"/> <input type="text" value="W"/>	<input type="text" value="S"/> <input type="text" value="1"/>	<input type="text" value="1"/> <input type="text" value="3"/> <input type="text" value="4"/>	<input type="text" value="1"/> <input type="text" value="3"/> <input type="text" value="4"/> <input type="text" value="5"/> <input type="text" value="6"/>
PVL	06 - 6mm Dia. 08 - 8mm Dia. 10 - 10mm Dia. 12 - 12mm Dia. 14 - 14mm Dia. 16 - 16mm Dia. 19 - 19mm Dia.	F - Flat R - Round	L - Solder Lug W - Wire Leads 150mm	S - Stainless Steel 1 - Black	1 - Red 3 - Green 4 - Blue	1 - Base Voltage* 3 - 6V 4 - 12V 5 - 24V 6 - 110V

NOTES:
 * Base voltage on LEDs:
 1.8V @ 20mA for Red, Yellow and Orange LED colors
 2.8V @ 20mA for Blue, Green and White LED colors

Specifications subject to change without notice 12.17.2020



E-SWITCH®

www.e-switch.com

800.867.2717

1

PVL SERIES PILOT INDICATOR

BODY DIMENSIONS

PVL06

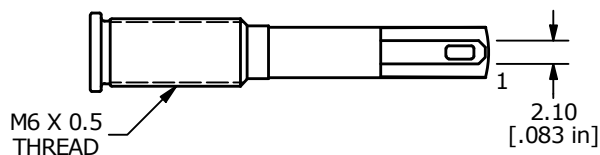
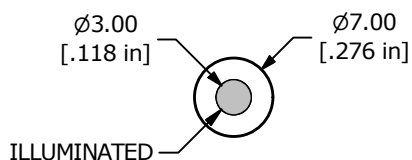
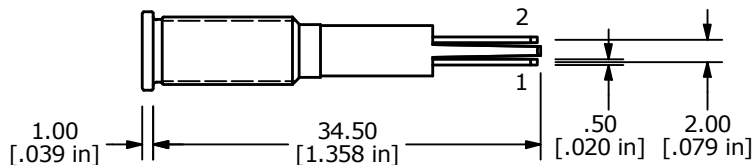
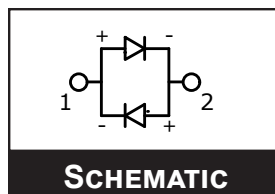
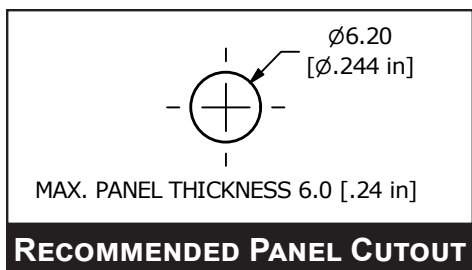

PVL08

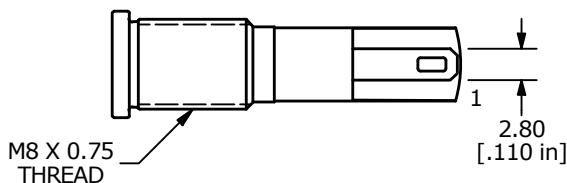
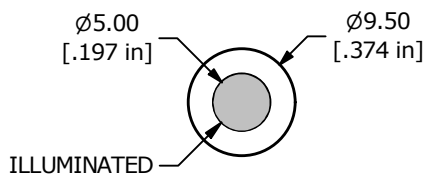
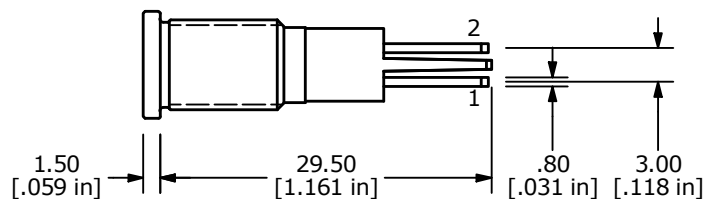
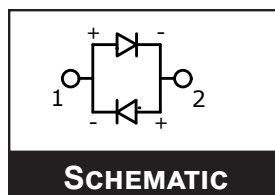
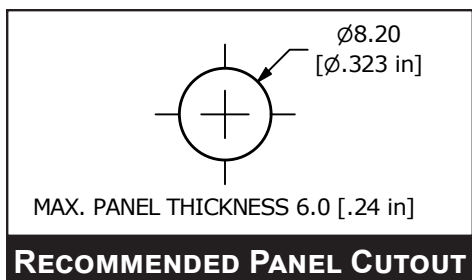

ANTI-VANDAL SWITCHES

DETECTOR SWITCHES

DIP SWITCHES

KEYLOCK SWITCHES

NAVIGATION SWITCHES

PUSHBUTTON SWITCHES

ROCKER SWITCHES

ROTARY SWITCHES

SLIDE SWITCHES

SNAP ACTION SWITCHES

TACTILE SWITCHES

TOGGLE SWITCHES

CAP OPTIONS



PVL SERIES PILOT INDICATOR

BODY DIMENSIONS

PVL10

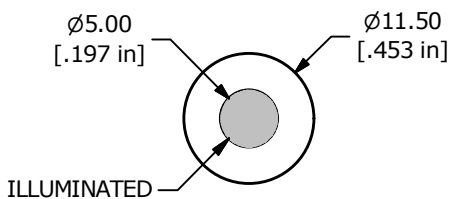
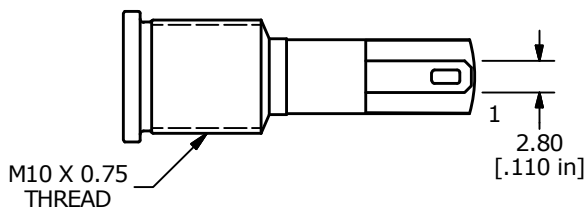
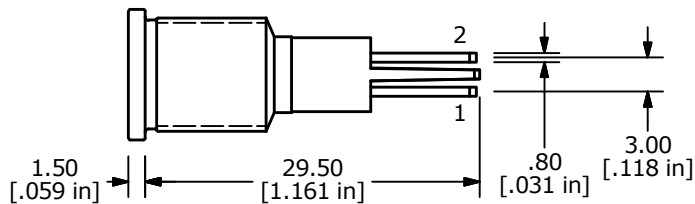
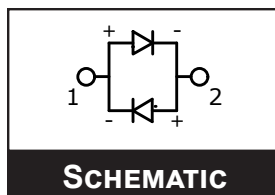
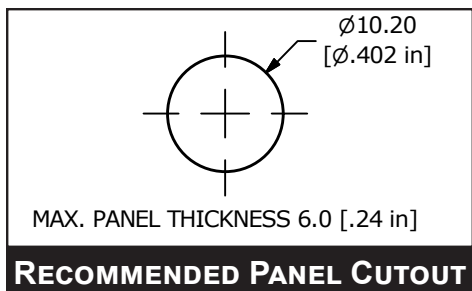

PVL12

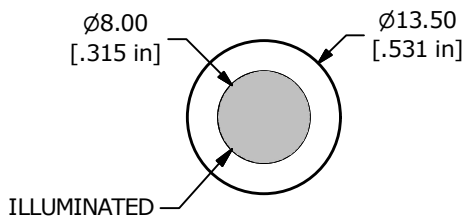
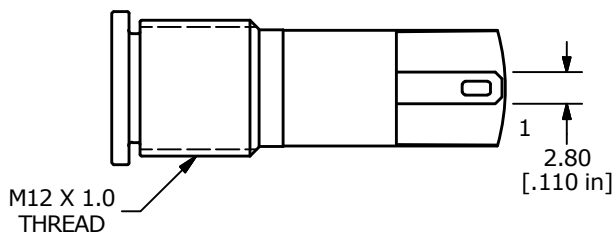
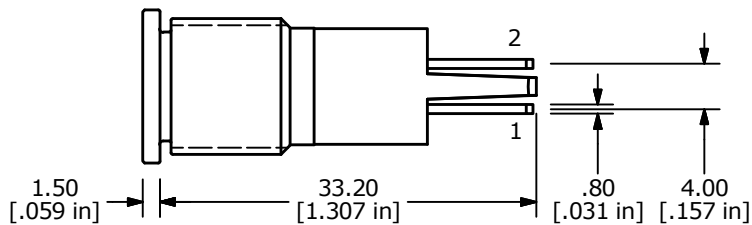
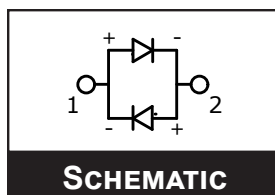
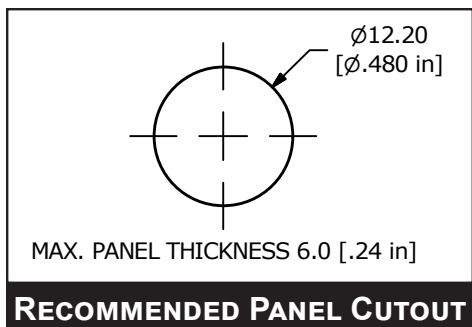

PVL SERIES PILOT INDICATOR

BODY DIMENSIONS

ANTI-VANDAL SWITCHES

DETECTOR SWITCHES

DIP SWITCHES

KEYLOCK SWITCHES

NAVIGATION SWITCHES

PUSHBUTTON SWITCHES

ROCKER SWITCHES

ROTARY SWITCHES

SLIDE SWITCHES

SNAP ACTION SWITCHES

TACTILE SWITCHES

TOGGLE SWITCHES

CAP OPTIONS

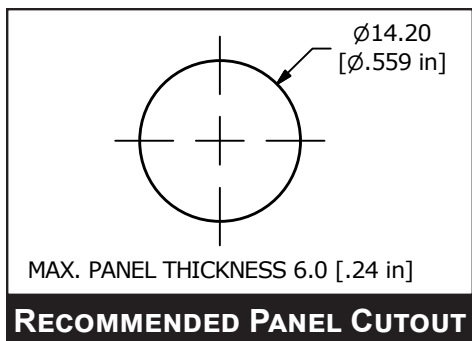

PVL14

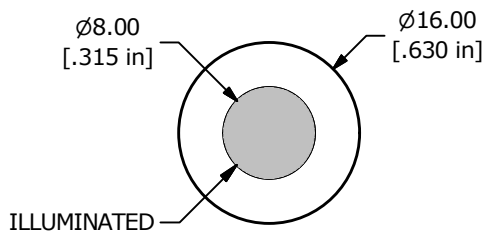
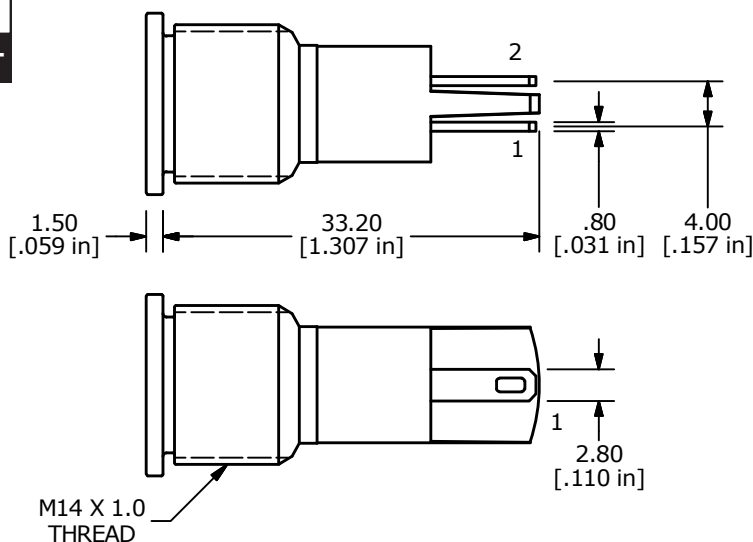
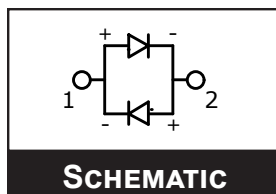

PVL16

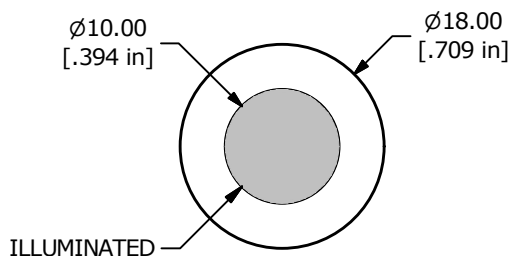
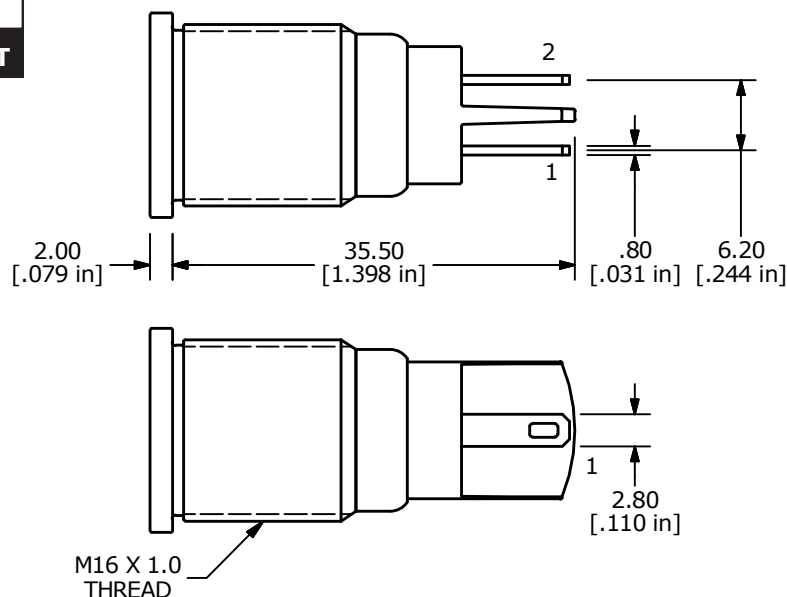
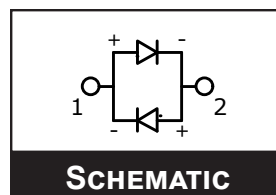
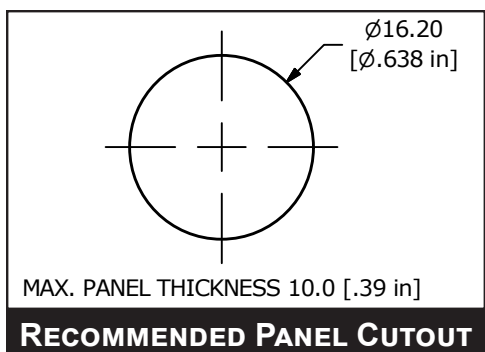

PVL SERIES PILOT INDICATOR

BODY DIMENSIONS

PVL19

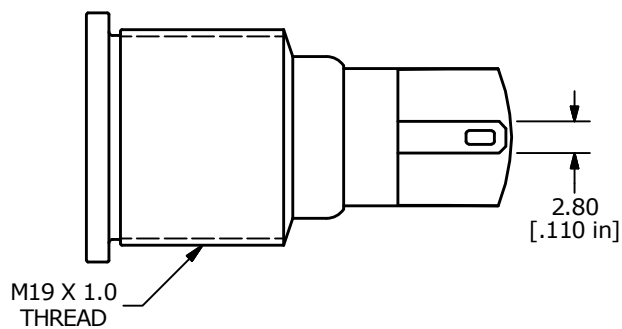
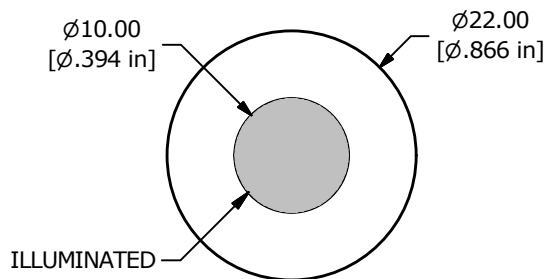
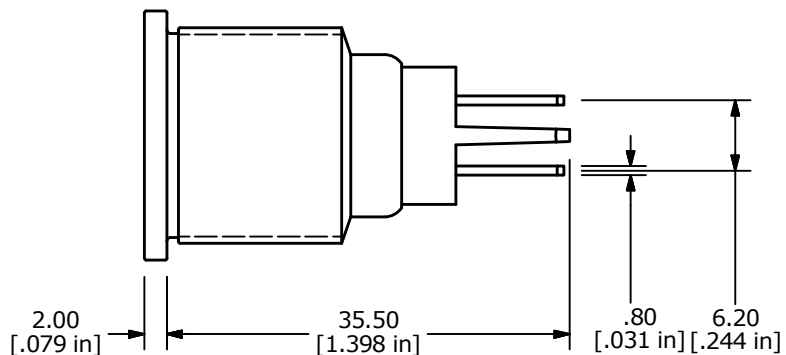
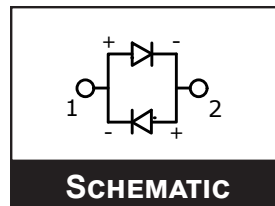
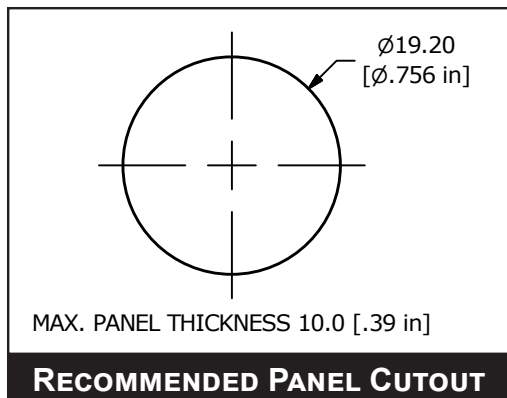

PVL SERIES PILOT INDICATOR

WIRE LEAD OPTIONS

PVL06

ADAPTER	WIRE	LENGTH
SW1-1	WIRE, 24 AWG AWM UL1061, BLACK	150.0 [5.9 in]
SW1-2	WIRE, 24 AWG AWM UL1061, BLACK	150.0 [5.9 in]

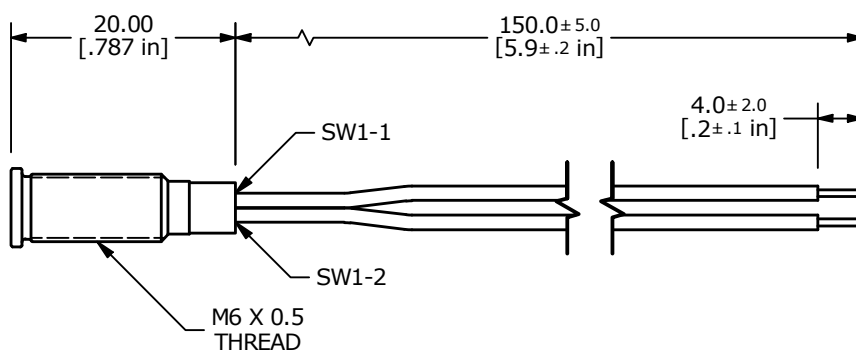
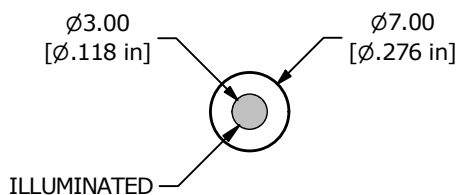
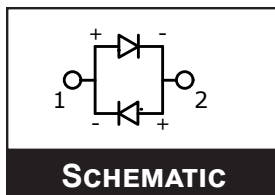
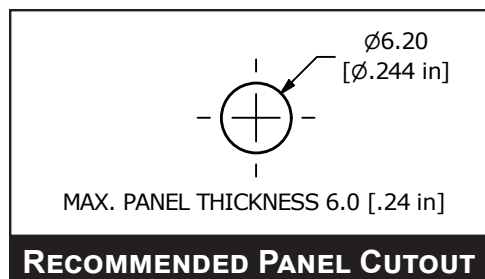

PVL08

ADAPTER	WIRE	LENGTH
SW1-1	WIRE, 24 AWG AWM UL1007, BLACK	150.0 [5.9 in]
SW1-2	WIRE, 24 AWG AWM UL1007, BLACK	150.0 [5.9 in]

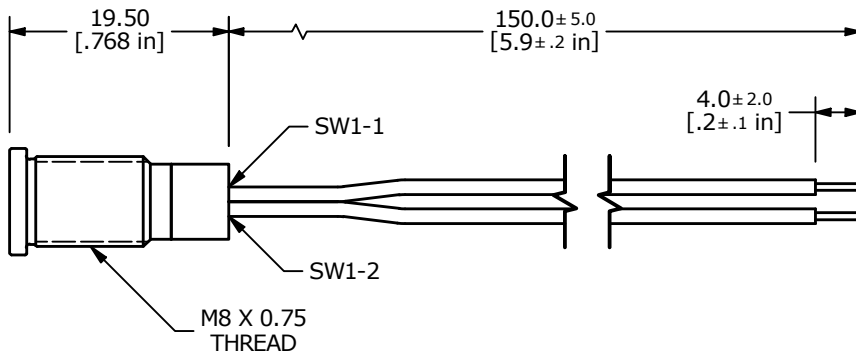
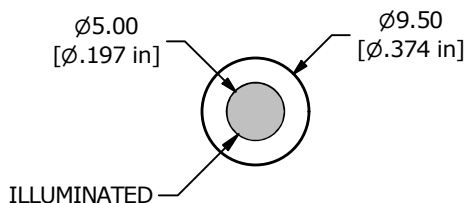
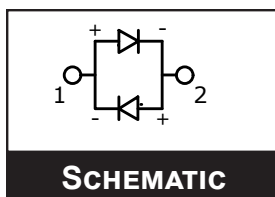
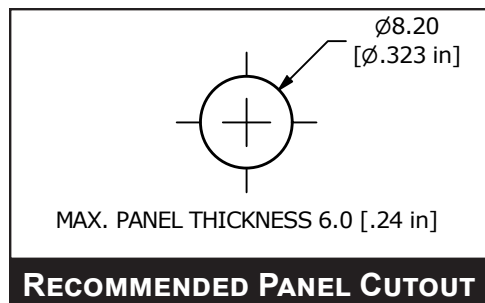

PVL SERIES PILOT INDICATOR

WIRE LEAD OPTIONS

PVL10

ADAPTER	WIRE	LENGTH
SW1-1	WIRE, 24 AWG AWM UL1007, BLACK	150.0 [5.9 in]
SW1-2	WIRE, 24 AWG AWM UL1007, BLACK	150.0 [5.9 in]

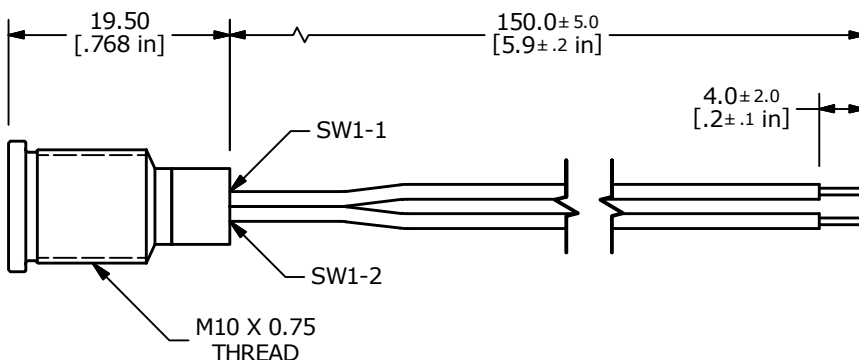
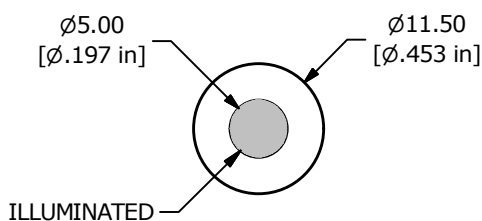
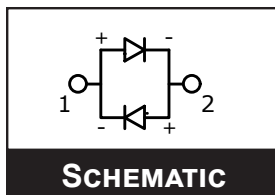
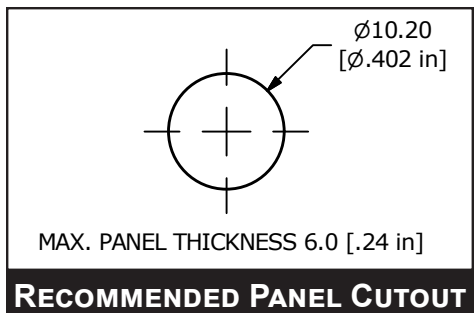

PVL12

ADAPTER	WIRE	LENGTH
SW1-1	WIRE, 24 AWG AWM UL1007, BLACK	150.0 [5.9 in]
SW1-2	WIRE, 24 AWG AWM UL1007, BLACK	150.0 [5.9 in]

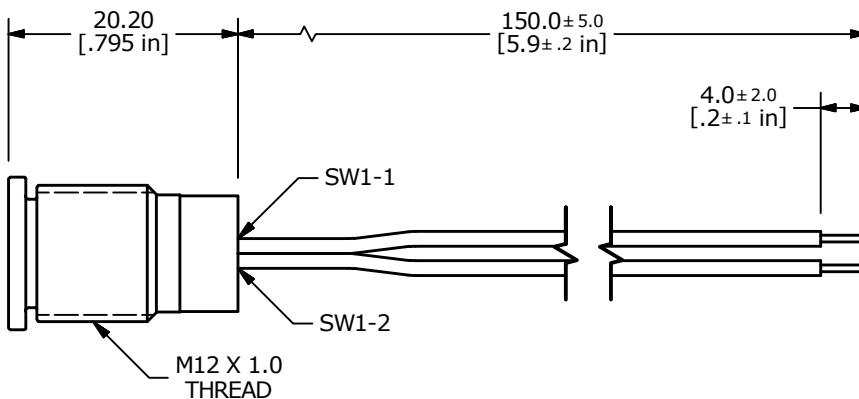
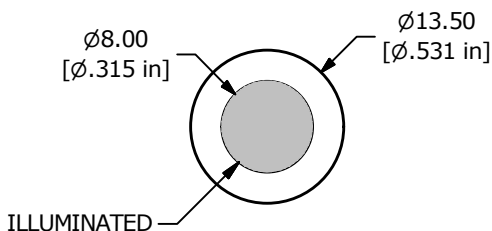
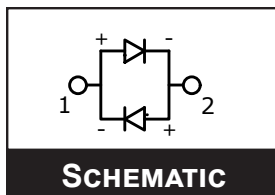
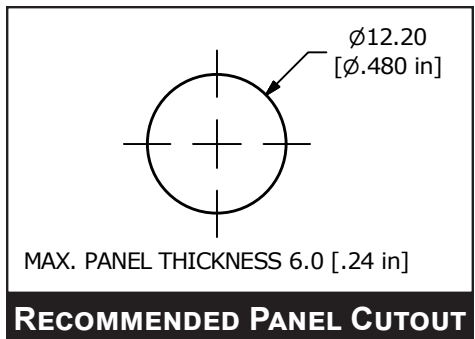

PVL SERIES PILOT INDICATOR

WIRE LEAD OPTIONS

PVL14

ADAPTER	WIRE	LENGTH
SW1-1	WIRE, 24 AWG AWM UL1007, BLACK	150.0 [5.9 in]
SW1-2	WIRE, 24 AWG AWM UL1007, BLACK	150.0 [5.9 in]

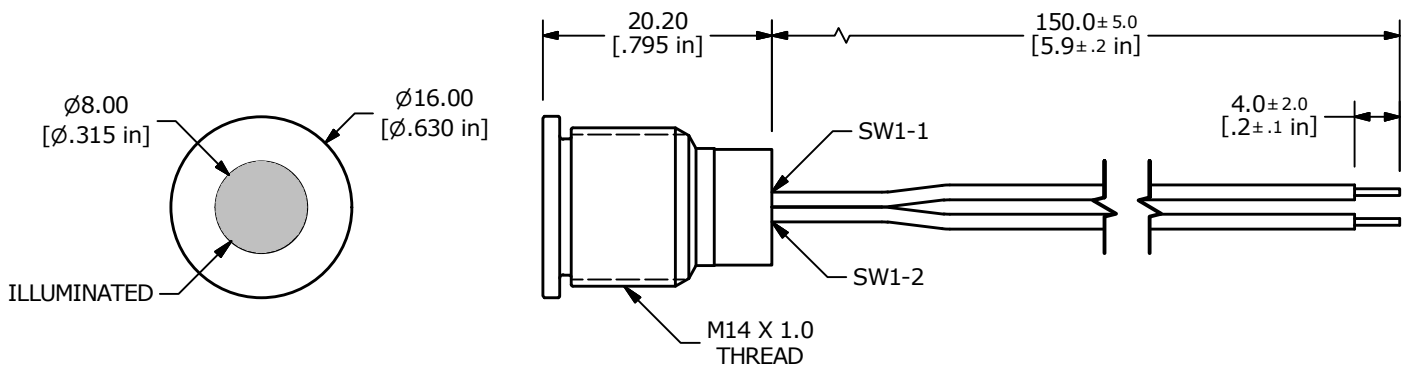
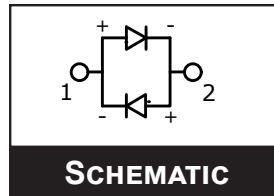
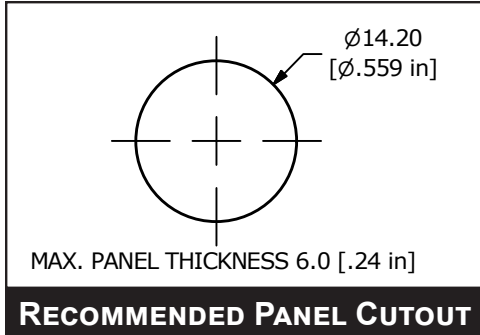

PVL16

ADAPTER	WIRE	LENGTH
SW1-1	WIRE, 24 AWG AWM UL1007, BLACK	150.0 [5.9 in]
SW1-2	WIRE, 24 AWG AWM UL1007, BLACK	150.0 [5.9 in]

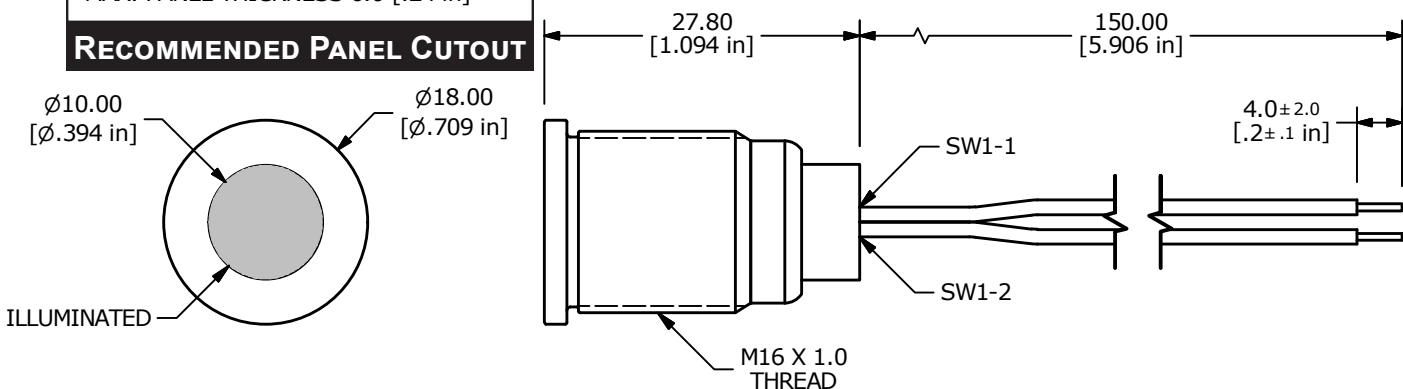
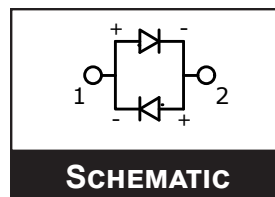
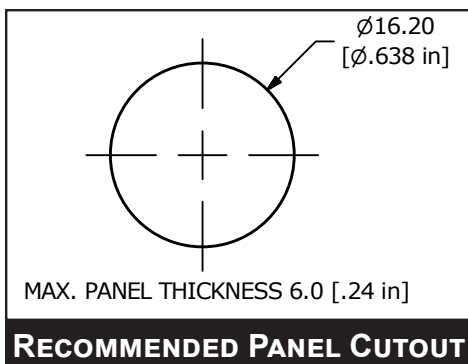

PVL SERIES PILOT INDICATOR

WIRE LEAD OPTIONS

PVL19

ADAPTER	WIRE	LENGTH
SW1-1	WIRE, 24 AWG AWM UL1007, BLACK	150.0 [5.9 in]
SW1-2	WIRE, 24 AWG AWM UL1007, BLACK	150.0 [5.9 in]

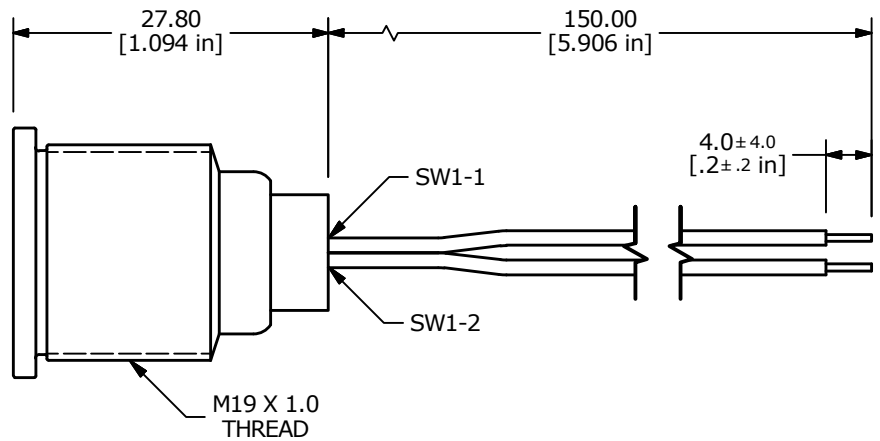
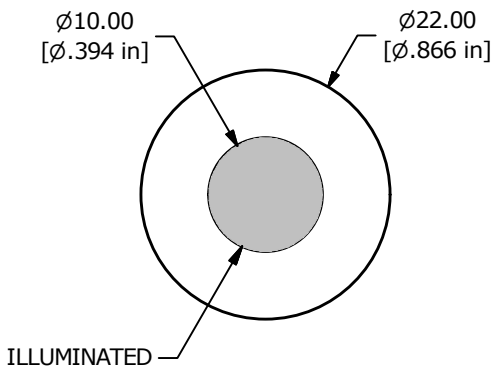
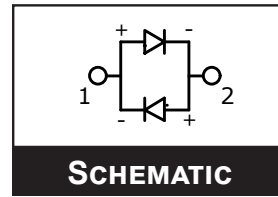
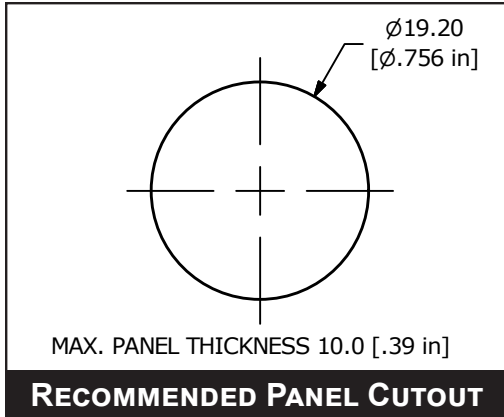

Mouser Electronics

Authorized Distributor

Click to View Pricing, Inventory, Delivery & Lifecycle Information:

[E-Switch:](#)

[PVL19FLS31](#) [PVL06FLS31](#) [PVL06FW111](#) [PVL06FWS11](#) [PVL12FLS11](#) [PVL10FWS34](#) [PVL14FWS35](#)
[PVL08FW131](#) [PVL12FLS41](#) [PVL08FW111](#) [PVL14FWS34](#) [PVL12FLS35](#)