

STRAIGHT FEMALE CONNECTOR

SOLDER CABLE .047

R201.051.000

Series : SMPM

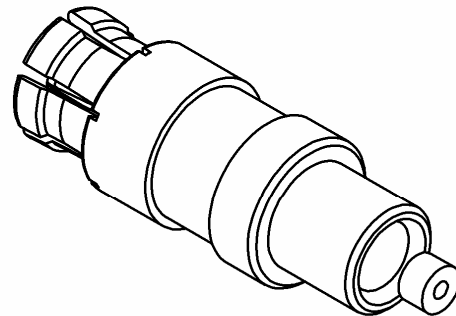
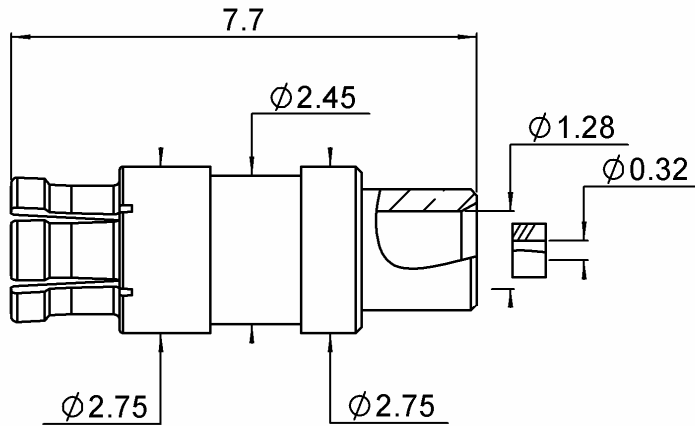

Scale : 1/1

All dimensions are in mm.

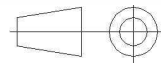

COMPONENTS	MATERIALS	PLATING (µm)
BODY	BERYLLIUM COPPER	GOLD 1.3 OVER NICKEL2
CENTER CONTACT	BERYLLIUM COPPER	GOLD 1.3 OVER NICKEL2
OUTER CONTACT	-	-
INSULATOR	PEEK	-
GASKET	-	-
OTHERS PARTS	-	-
-	-	-
-	-	-

Issue : 1134 A

In the effort to improve our products, we reserve the right to make changes judged to be necessary.



STRAIGHT FEMALE CONNECTOR

R201.051.000

SOLDER CABLE .047

Series : SMPM

PACKAGING

Standard	Unit	Other
100	'W' option	Contact us

SPECIFICATION

ELECTRICAL CHARACTERISTICS

Impedance		50 Ω
Frequency		0-40 GHz
VSWR	*1.35 +	0,0000 x F(GHz) Maxi
Insertion loss		0.12 √F(GHz) dB Maxi
RF leakage	- (NA - F(GHz)) dB Maxi
Voltage rating		335 Veff Maxi
Dielectric withstanding voltage		500 Veff mini
Insulation resistance		5000 MΩ mini

CABLE ASSEMBLY

Stripping	a	b	c	d	e	f
mm	1,30	0,00	0,00	0,00	0,00	0,00

Assembly instruction :

Recommended cable(s)
UT47 M17/151-00001

MECHANICAL CHARACTERISTICS

Center contact retention		
Axial force – Mating end	6.7	N mini
Axial force – Opposite end	6.7	N mini
Torque	NA	N.cm mini

Characteristics indicated on this data sheet are those that can be achieved with the highest performance cable. Intrinsic limitations of the cable may diminish the performance of the assembly

Cable retention

- pull off	45	N mini
- torque	NA	N.cm

TOOLING

Part Number	Description	Hexagon
R282.743.110	POSITIONER FOR SOLDERING SMPM	
R282.740.020	SOLDERING MOUNTING	

Recommended torque		
Mating	NA	N.cm
Panel nut	NA	N.cm
Clamp nut	NA	N.cm
A/F clamp nut	0,0000	mm
Mating life	500	Cycles mini
Weight	0,1700	g

OTHER CHARACTERISTICS

*VSWR 1.15 AT 26.5 GHz

ENVIRONMENTAL

Operating temperature	-40/+100	° C
Hermetic seal	NA	Atm.cm3/s
Panel leakage	NA	

Issue : 1134 A

In the effort to improve our products, we reserve the right to make changes judged to be necessary.



STRAIGHT FEMALE CONNECTOR
SOLDER CABLE .047

R201.051.000

Series : SMPM

COMPONENT

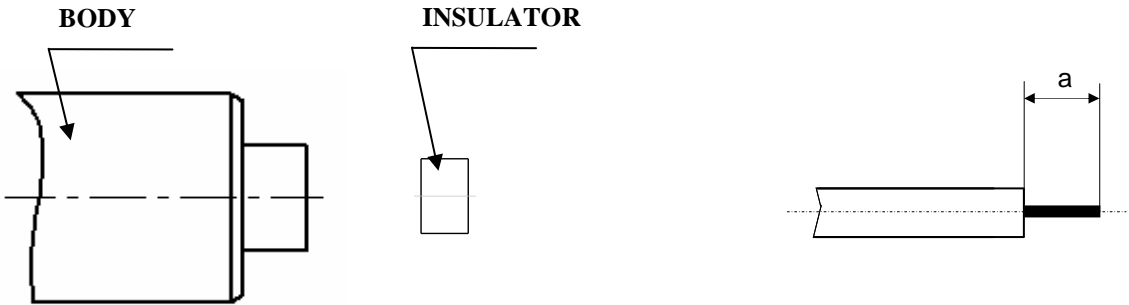

We recommend a cable thermal preconditioning before assembly

1

- Strip the cable.
- Trim the cable inner conductor.
- Clean the cable

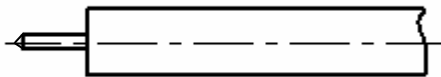

3

- Slide body into the positioner.
- Introduce the cable into the connector body until it stops.
- Place the sub assembly into the assembly and tighten it .
- Solder the body onto the cable.
- After cooling remove cable assembly from the jig.

Soldering jig

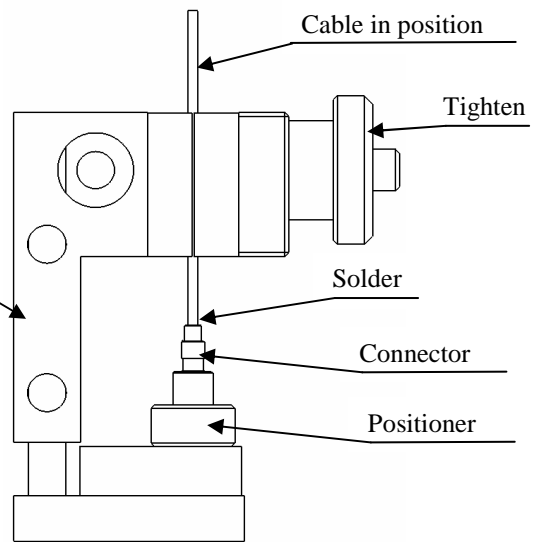

2

- Slide the insulator onto the cable inner conductor.

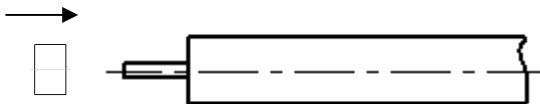

Issue : 1134 A

In the effort to improve our products, we reserve the right to make changes judged to be necessary.



Mouser Electronics

Authorized Distributor

Click to View Pricing, Inventory, Delivery & Lifecycle Information:

Radial:

[R201051000](#) [R201051000W](#)