

HDI Series

Amplified pressure sensors

FEATURES

- 10 mbar to 5 bar, absolute, gage or differential pressure
- Digital I²C-bus and analog output
- Precision ASIC signal conditioning
- Calibrated and temperature compensated
- SMT and DIP housings
- RoHS compliant

MEDIA COMPATIBILITY

To be used with non-corrosive, non-ionic working fluids such as clean dry air, dry gases and the like.

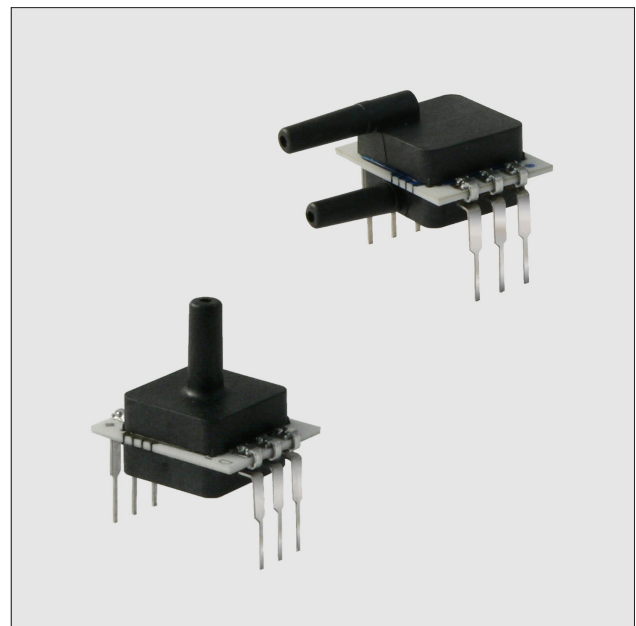

SPECIFICATIONS

Maximum ratings

Supply voltage V_s	
HDI...3	2.7 ... 3.3 V _{DC}
HDI...5	4.5 ... 5.5 V _{DC}
	max. 6.50 V _{DC}

Output current	
Sink	1 mA
Source	1 mA

Lead specifications	
Average preheating temperature gradient	2.5 K/s
Soak time	ca. 3 min
Time above 217°C	50 s
Time above 230°C	40 s
Time above 250°C	15 s
Peak temperature	260°C
Cooling temperature gradient	-3.5 K/s

Temperature ranges ⁵	
Compensated	0 ... +85 °C
Operating	-20 ... +85 °C
Storage	-40 ... +125 °C

ELECTRICAL CONNECTION

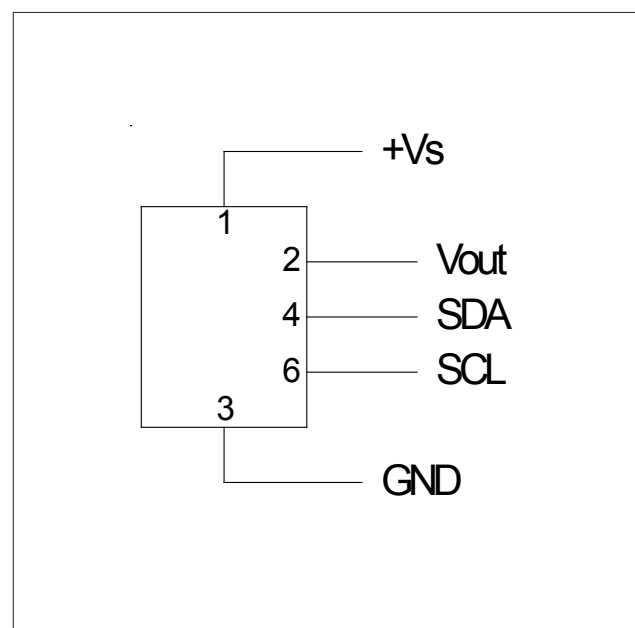

HDI Series

Amplified pressure sensors

PRESSURE SENSOR CHARACTERISTICS

(T_A=25 °C, RH=50 %)

Part no.	Operating pressure	Proof pressure ¹	Burst pressure ²
HDIM010...B...	0...±10 mbar	150 mbar	200 mbar
HDIM020...B...	0...±20 mbar	150 mbar	200 mbar
HDIM050...B...	0...±50 mbar	550 mbar	800 mbar
HDIM100...B...	0...±100 mbar	1 bar	1.5 bar
HDIM200...B...	0...±200 mbar	1 bar	1.5 bar
HDIM500...B...	0...±500 mbar	1 bar	1.5 bar
HDIB001...B...	0...±1 bar	2 bar	3 bar
HDIM010...U...	0...10 mbar	150 mbar	200 mbar
HDIM020...U...	0...20 mbar	150 mbar	200 mbar
HDIM050...U...	0...50 mbar	550 mbar	800 mbar
HDIM100...U...	0...100 mbar	1 bar	1.5 bar
HDIM200...U...	0...200 mbar	1 bar	1.5 bar
HDIM500...U...	0...500 mbar	1 bar	1.5 bar
HDIB001...U...	0...1 bar	2 bar	3 bar
HDIB002...U...	0...2 bar	4 bar	6 bar
HDIB005...U...	0...5 bar	7 bar	7 bar
HDI0611AR...	600...1100 mbar(a)	2 bara	3 bara
HDI0811AR...	800...1100 mbar(a)	2 bara	3 bara

Other pressure ranges are available on request. Please contact First Sensor.

1. Proof pressure is the maximum pressure which may be applied without causing durable shifts of the electrical parameters of the sensing element.
2. Burst pressure is the maximum pressure which may be applied without causing damage to the sensing element or leaks to the housing.
3. Full Scale Span (FSS) is the algebraic difference between the output signal for the highest and lowest specified pressure.
4. Total accuracy is the combined error from offset and span calibration, linearity, pressure hysteresis, and temperature effects. Linearity is the measured deviation based on a straight line. Hysteresis is the maximum output difference at any point within the operating pressure range for increasing and decreasing pressure. Calibration errors include the deviation of offset and full scale from nominal values.
5. Extended temperature ranges on request. Please contact First Sensor.
6. Max. delay time between pressure change at the pressure die and signal change at the output.
7. The response time depends on the adjusted internal A/D resolution of the sensor. For 12 bit it is typ. 0.5 ms. Other A/D resolutions and response time are available on request. Please contact First Sensor for further information.
8. Sensors with lower current consumption are available on request. Please contact First Sensor for further information.

HDI Series

Amplified pressure sensors

PERFORMANCE CHARACTERISTICS

($V_S=5.0 V_{DC}$, $T_A=25\text{ }^\circ\text{C}$, $RH=50\%$, analog output signal is **ratiometric** to V_S , digital output signal is **not ratiometric** to V_S)

All HDI...P5 devices ($V_S = 5.0$)

Characteristics	Min.	Typ.	Max.	Units
Total accuracy (0...85°C) ⁴	all barometric devices		±1.0	%FSS
	all other devices		±0.5	
Response delay ^{6,7}		0.5		ms
A/D resolution ⁷		12		bit
D/A resolution			11	
Current consumption ⁸		5		mA

All HDI...R...P5 (barometric devices)

Characteristics	Min.	Typ.	Max.	Units
ANALOGUE PERFORMANCE CHARACTERISTIC				
Output at min. specified pressure	0.46	0.50	0.54	V
Full scale span (FSS) ³		4.00		
Full scale output	4.46	4.50	4.54	
DIGITAL PERFORMANCE CHARACTERISTIC				
Output at min. specified pressure	3015	3277	3539	counts
Full scale span (FSS) ³		26214		
Full scale output	29228	29490	29752	

All HDI...U...P5 (unidirectional devices)

Characteristics	Min.	Typ.	Max.	Units
ANALOG PERFORMANCE CHARACTERISTIC				
Zero pressure offset	0.48	0.50	0.52	V
Full scale span (FSS) ³		4.00		
Full scale output	4.48	4.50	4.52	
DIGITAL PERFORMANCE CHARACTERISTIC				
Zero pressure offset	3146	3277	3408	counts
Full scale span (FSS) ³		26214		
Full scale output	29359	29490	29621	

All HDI...B...P5 (bidirectional devices)

Characteristics	Min.	Typ.	Max.	Units	
ANALOG PERFORMANCE CHARACTERISTIC					
Zero pressure offset	2.48	2.50	2.52	V	
Full scale span (FSS) ³		4.00			
Output	at max. specified pressure	4.48	4.50		4.52
	at min. specified pressure	0.48	0.50		0.52
DIGITAL PERFORMANCE CHARACTERISTIC					
Zero pressure offset	16252	16384	16515	counts	
Full scale span (FSS) ³		26214			
Output	at max. specified pressure	29359	29490		29621
	at min. specified pressure	3146	3277		3408

HDI Series

Amplified pressure sensors

PERFORMANCE CHARACTERISTICS

($V_S=3.0 V_{DC}$, $T_A=25\text{ }^\circ\text{C}$, $RH=50\%$, analog output signal is **ratiometric** to V_S , digital output signal is **not ratiometric** to V_S)

All HDI...P3 devices ($V_S = 3.0$)

Characteristics	Min.	Typ.	Max.	Units
Total accuracy (0...85°C) ⁴	all barometric devices		±1.0	%FSS
	all other devices		±0.5	
Response delay ^{6,7}		0.5		ms
A/D resolution ⁷		12		bit
D/A resolution			11	
Current consumption ⁸		3		mA

All HDI...R...P3 (barometric devices)

Characteristics	Min.	Typ.	Max.	Units
ANALOGUE PERFORMANCE CHARACTERISTIC				
Output at min. specified pressure	0.23	0.25	0.27	V
Full scale span (FSS) ³		2.00		
Full scale output	2.23	2.25	2.27	
DIGITAL PERFORMANCE CHARACTERISTIC				
Output at min. specified pressure	2512	2731	2949	counts
Full scale span (FSS) ³		21845		
Full scale output	24357	24575	24794	

All HDI...U...P3 (unidirectional devices)

Characteristics	Min.	Typ.	Max.	Units
ANALOG PERFORMANCE CHARACTERISTIC				
Zero pressure offset	0.24	0.25	0.26	V
Full scale span (FSS) ³		2.00		
Full scale output	2.24	2.25	2.26	
DIGITAL PERFORMANCE CHARACTERISTIC				
Zero pressure offset	2621	2731	2840	counts
Full scale span (FSS) ³		21845		
Full scale output	24466	24575	24684	

All HDI...B...P3 (bidirectional devices)

Characteristics	Min.	Typ.	Max.	Units
ANALOG PERFORMANCE CHARACTERISTIC				
Zero pressure offset	1.24	1.25	1.26	V
Full scale span (FSS) ³		2.00		
Output	at max. specified pressure		2.24	
	at min. specified pressure		0.24	
DIGITAL PERFORMANCE CHARACTERISTIC				
Zero pressure offset	13545	13653	13762	counts
Full scale span (FSS) ³		21845		
Output	at max. specified pressure		24466	
	at min. specified pressure		2621	

I²C Interface Parameters

Parameter	Symbol	Min.	Typ.	Max.	Unit
Input high level		90		100	% of V _s
Input low level		0		10	
Output low level				10	
Pull-up resistor		500			Ω
Load capacitance @ SDA	C _{SDA}			400	pF
Input capacitance @ SDA/SCL	C _{I2C IN}			10	
SCL clock frequency	F _{SCL}	100*		400	kHz
Bus free time between STOP and START condition	t _{BUF}	1.3			μs
Hold time (repeated) START condition, to first clock pulse	t _{HD,STA}	0.8			
LOW period of SCL	t _{LOW}	1.3			
HIGH period of SCL	t _{HIGH}	0.6			
Setup time repeated START condition	t _{SU,STA}	1			
Data hold time	t _{HD,DAT}	0			
Data setup time	t _{SU,DAT}	0.2			
Rise time of both SDA and SCL	t _R			0.3	
Fall time of both SDA and SCL	t _F			0.3	
Setup time for STOP condition	t _{SU,STO}	0.6			

* recommended

Note: First Sensor recommends communication speeds of at least 100 kHz (max. 400 kHz). Please contact us for further information.

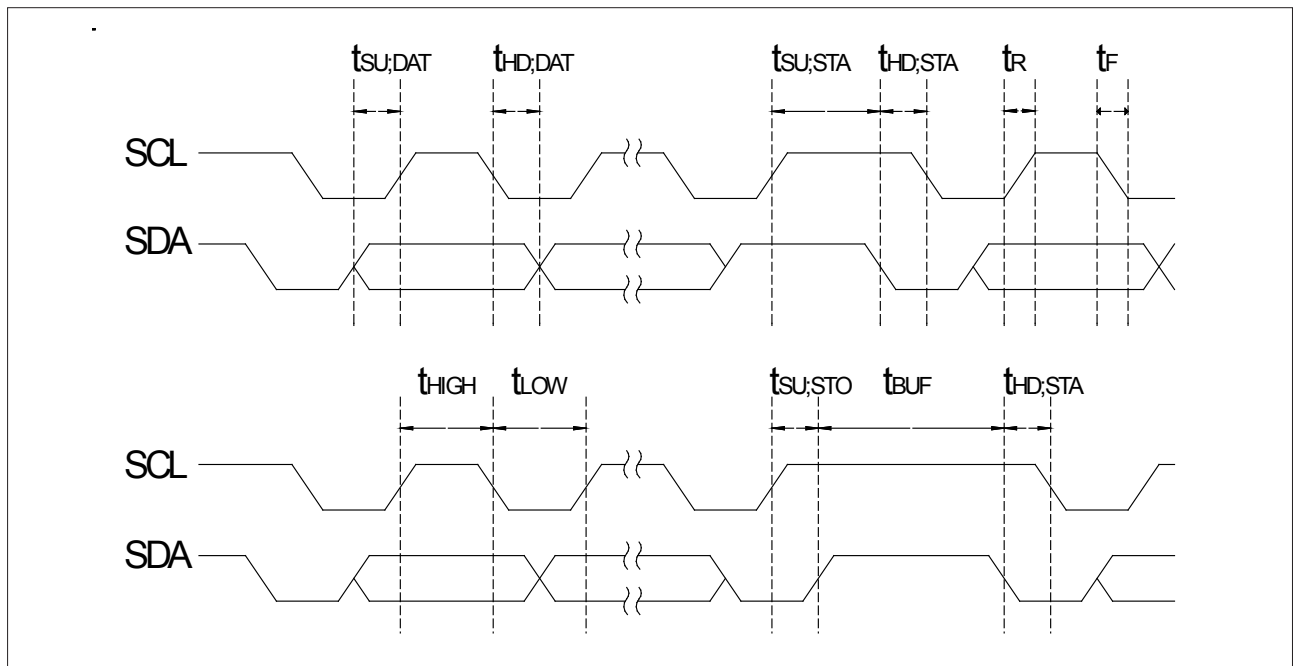

Fig. 2: Timing characteristics

HDI Series

Amplified pressure sensors

PHYSICAL DIMENSIONS

HDI...F... (DIP, 2 ports same side)

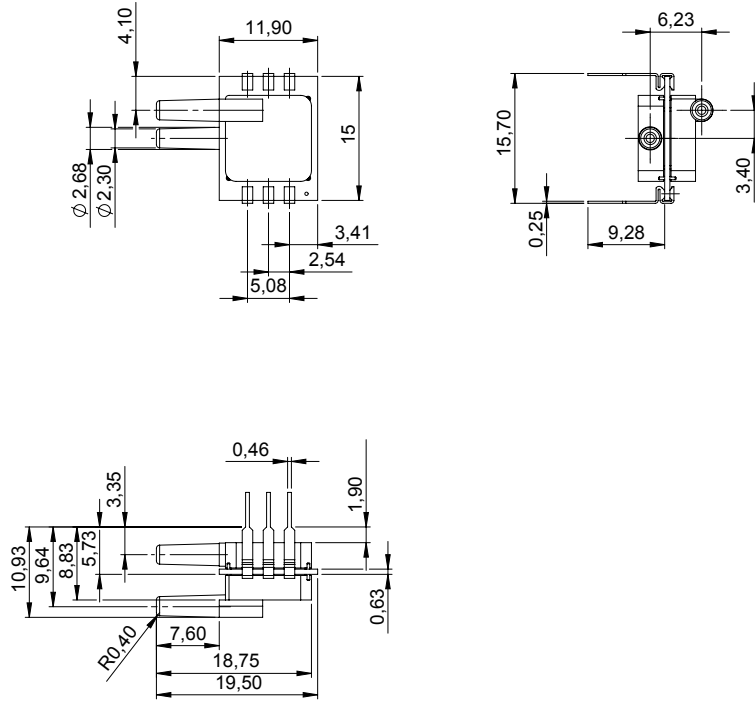

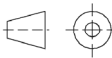
 first angle projection
 dimensions in mm

HDI...E... (SMD, 2 ports same side)

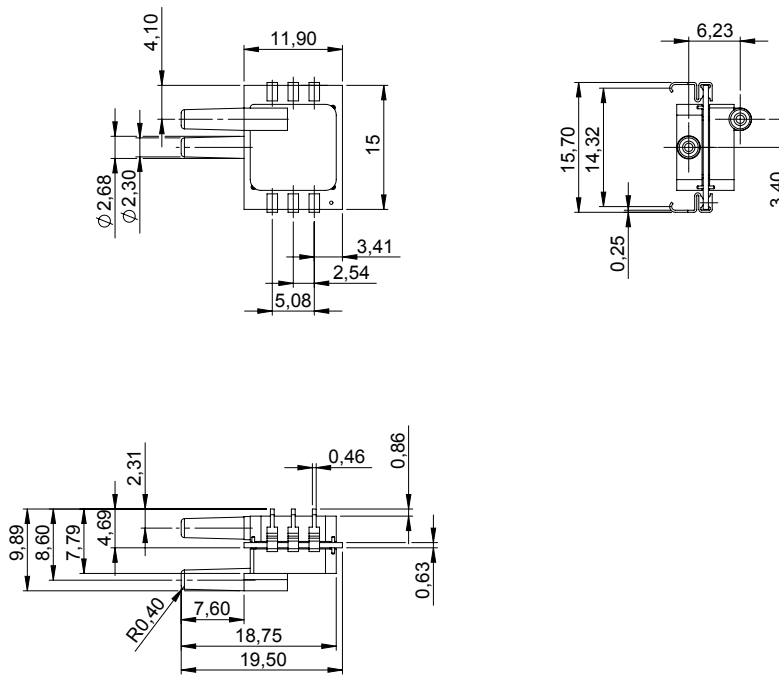

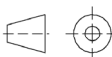

 first angle projection
 dimensions in mm

HDI Series

Amplified pressure sensors

PHYSICAL DIMENSIONS (cont.)

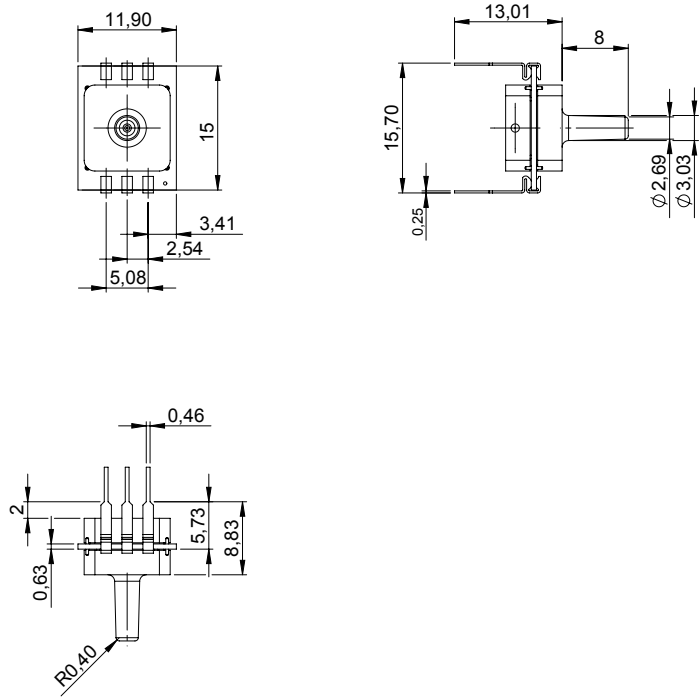
HDI...Z... (DIP, 1 port axial)

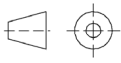

 first angle projection
 dimensions in mm

HDI...Y... (SMD, 1 port axial)

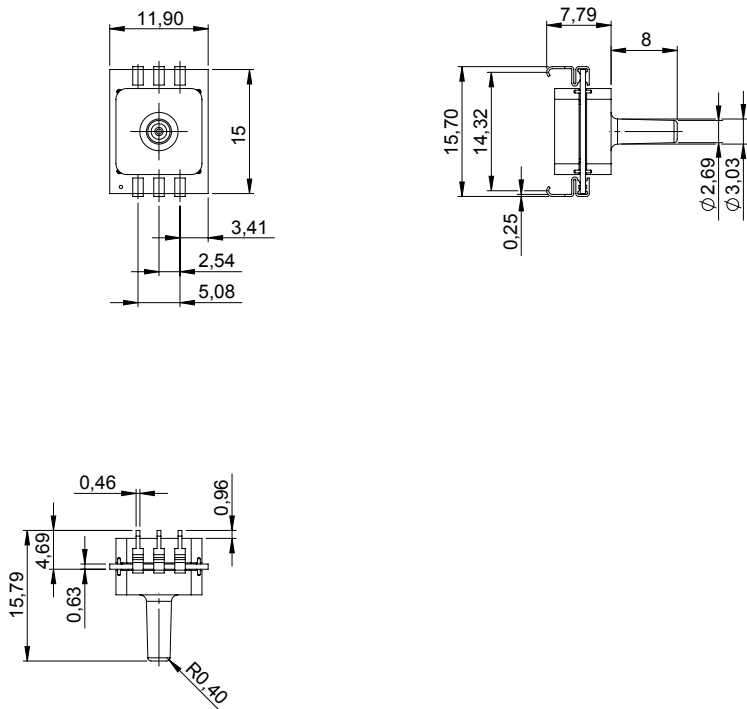

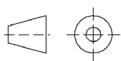

 first angle projection
 dimensions in mm

HDI Series

Amplified pressure sensors

ELECTRICAL CONNECTION (cont.)

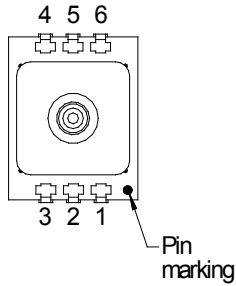
HDI...A...
(absolute)



HDI...G...
(gage)

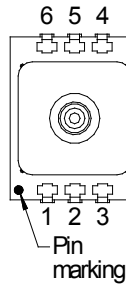

HDI...D...
(differential)

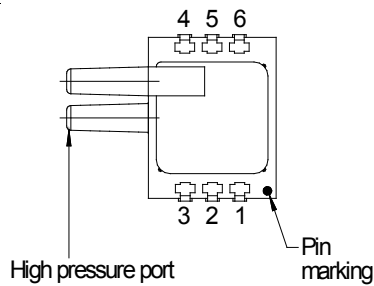

Pin	Connection
1	+Vs
2	+Vout
3	GND
4	SDA
5	I / C*
6	SCL

* Internal connection.
Do not connect for any reason

ORDERING INFORMATION

Options	Series	Pressure range		Pressure mode		Calibration		Housing		Porting		Grade		Voltage	
	HDI	0611	600...1100 mbar	A*	Absolute	B*	Bidirectional	F*	DIP, 2 ports same side	8	Straight	P	Prime	5	5 V
		0811	800...1100 mbar	D	Differential	U	Unidirectional	E*	SMD, 2 ports same side					3	3 V
		M010	10 mbar	G	Gage	R**	Barometric	Z**	DIP, 1 port axial						
		M020	20 mbar					Y**	SMD, 1 port axial						
		M050	50 mbar												
		M100	100 mbar												
		M200	200 mbar												
		M500	500 mbar												
		B001	1 bar												
		(B001A)	1 bara												
		B002	2 bar												
		B005	5 bar												
				* only from 1 bar		* only up to 1 bar ** for pressure ranges 0611, 0811		* standard for differential devices, "D" ** standard for absolute and gage devices, "A" and "G"							
Example:		HDI	M050	G		U		Z		8		P		5	

Note: Not all possible sensor configurations are active products. MOQ may apply.

Custom specific pressure ranges and mechanical or electronic sensor modifications are widely available. Please contact First Sensor for further information.

First Sensor reserves the right to make changes to any products herein. First Sensor does not assume any liability arising out of the application or use of any product or circuit described herein, neither does it convey any license under its patent rights nor the rights of others.

Mouser Electronics

Authorized Distributor

Click to View Pricing, Inventory, Delivery & Lifecycle Information:

TE Connectivity:

[HDIM050DUF8P5](#) [HDIM020DUF8P5](#) [HDIM100DBE8P5](#) [HDIM200DUE8P5](#) [HDIM500GUY8P5](#) [HDIM100DUE8P5](#)
[HDIM020DUE8P3](#) [HDIM100DBE8P3](#)