

The history of revision change for the specification

Document	REV.	Modified date	Description
CYNVA-175-001	A0	2017.5.23	New Approval
CYNVA-175-001	A1	2017.6.20	1. May -> Jun. 2. Add spec of 3R3, 5R0 ; add curve of 3R3, 5R0
CYNVA-175-001	A2	2017.11.13	1. Jun. -> Nov. 2. Add spec of 1R0 3. Add curve of 1R0
CYNVA-175-001	A3	2018.3.14	1. Add "AEC-Q200" logo on page 2 2. Nov., 2017 -> Mar., 2018 3. Year code 2017 = 7 -> 2018 = 8
CYNVA-175-001	A4	2018.10.19	1. Mar. -> Oct. 2. Remove spec of 5R0 3. Remove curve of 5R0
CYNVA-175-001	A5	2019.10.3	1. Oct., 2018 -> Oct., 2019 2. Year code: 2018 = 8 -> 2019 = 9 3. Remove 8R2 spec and curve.
CYNVA-175-001	A6	2020.1.20	1. Oct., 2019 -> Jan., 2020 2. Year code: 2019 = 9 -> 2020 = 0 3. Remove frequency: (1MHz) from Features
CYNVA-175-001	A7	2021.8.2	1. Jan., 2020 -> Aug., 2021 2. Year code: 2020 = 0 -> 2021 = 1 3. Add Rated voltage (V): 75V
CYNVA-175-001	A8	2024.09.13	1. Aug., 2021 -> Sep., 2024 2. Year code 2021 = 1 -> 2024 = 4 3. Add notice 'Shielded construction' in Features 4. Reflow Soldering : 217°C -> ≥217°C

Power Choke Coil VAMV1009AA MM2 type (Mylar Cap)

AEC-Q200

■ Features

High performance (Isat) realized by metal dust core.
 Low profile : Thickness 11.05mm Max.
 Low loss realized with low DCR
 Capable of corresponding high frequency
 Compliance with RoHS and Halogen Free
 Shielded construction
 AEC-Q200 qualified

■ Application

Automotive applications

■ Outline Dimensions

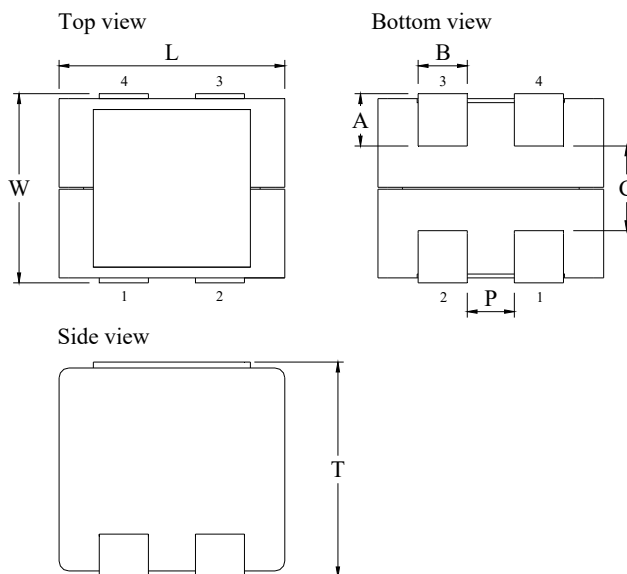

Code	Dimensions (mm)
L	10.2 ± 0.2
W	9.2 ± 0.2
T	10.85 ± 0.20
A	2.65 ± 0.20
B	2.5 ± 0.2
C	4.3 typ.
P	2.4 ± 0.2

■ Schematic

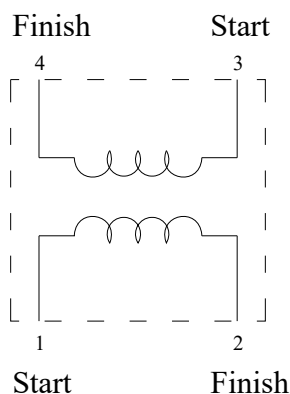

Recommend Land Pattern Dimensions

The customer shall determine the land dimensions shown below after confirming and safety.

Top View

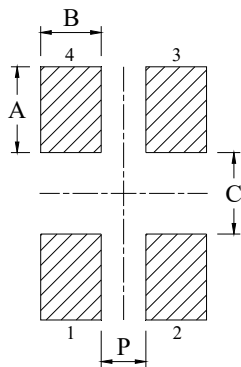

A	4.05
B	2.85
C	3.84
P	2.1

Unit : mm

Marking and Date Code

(1) Marking

The inductor is marked with a 3-digit code.

Example -- 10.0 μ H → 100

(2) Date code

X XX

(1) (2)

XXX

(3)

Where (1) Year code

Ex : 2024 = 4

(2) Weekly code

Serial number : 01 ~ 53

(3) Taping no.

Serial number : 001 ~ ZZZ

Upside of Choke

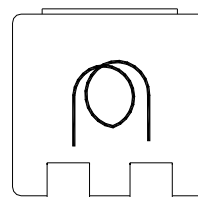
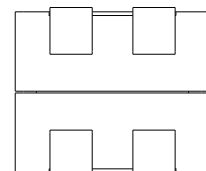
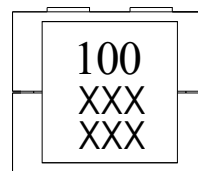

■ Specifications

Part Number	L0 ◇ Inductance (μ H) @ (0A)	R _{dc} (m Ω) ◇		Heat Rating Current DC Amps. I _{dc} (A)		Saturation Current DC Amps. I _{sat} (A)		Rated Voltage (V)
		Typical	Maximum	Typical	Maximum	Typical	Maximum	Maximum
VAMV1009AA-1R0MM2	1.0	3.3	4.0	13.0	12.0	50.0	43.0	75
VAMV1009AA-2R2MM2	2.2	5.0	6.0	10.0	9.0	32.0	27.5	75
VAMV1009AA-3R3MM2	3.3	7.5	8.6	9.0	8.0	26.0	23.4	75
VAMV1009AA-5R6MM2	5.6	14.0	16.8	6.4	5.8	19.0	16.0	75
VAMV1009AA-100MM2	10.0	18.0	22.0	5.8	5.2	12.0	10.0	75
VAMV1009AA-150MM2	15.0	34.0	40.8	4.5	4.0	9.0	7.7	75
VAMV1009AA-220MM2	22.0	46.0	56.0	3.6	3.2	8.5	7.3	75

◇ : Significant Characteristic

Note 1. : Inductance tolerance \pm 20%

Note 2. : All test data is referenced to 25°C ambient.

Note 3. : MS Level: Level 1.

Note 4. : Test condition:100KHz, 1.0Vrms

Note 5. : I_{dc} : DC current (A) that will cause an approximate Δ T of 40°C

Note 6. : I_{sat} : DC current (A) that will cause L0 to drop approximately 25%

Note 7. : Operating temperature range -55°C to + 125°C

Note 8. : The part temperature (ambient + temp rise) should not exceed 125°C under the worst case operating conditions. Circuit design, component placement, PCB trace size and thickness, airflow and other cooling provision all affect the part temperature. Part temperature should be verified in the end application.

Note 9. : The rated current as listed is either the saturation current or the heating current depending on which value is lower.

Note 10. : Cleaning process note

- (a) If this power choke is dipped in the cleaning agent, such as toluene, xylene, ketone, and ether system, there is a possibility that the performance decreases greatly.
- (b) The high power ultrasonic washing may damage the choke body.
- (c) Please contact us if you need the cleaning via the above agents or ultrasonic washing.

Note 11. : If you require another part number, please contact with us.

Current Characteristic

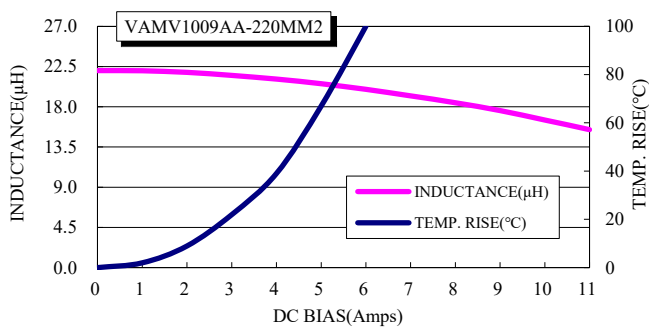
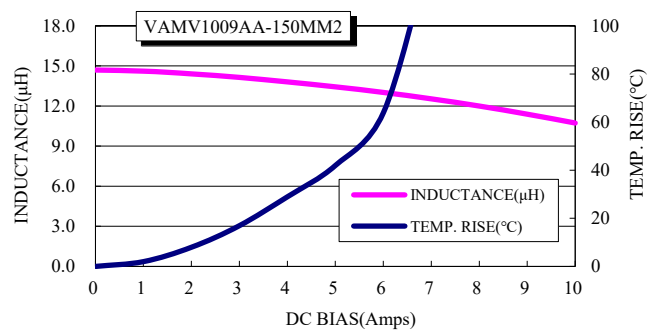
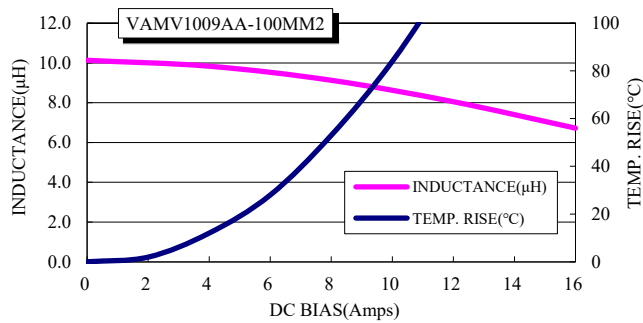
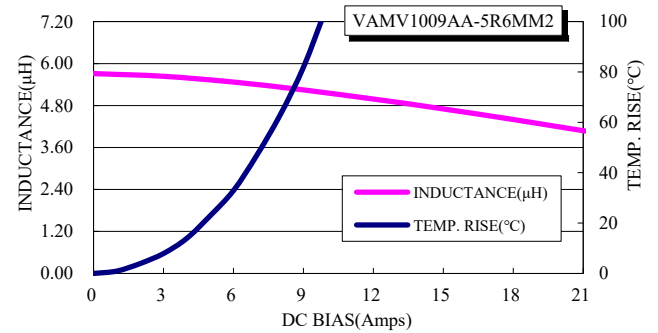
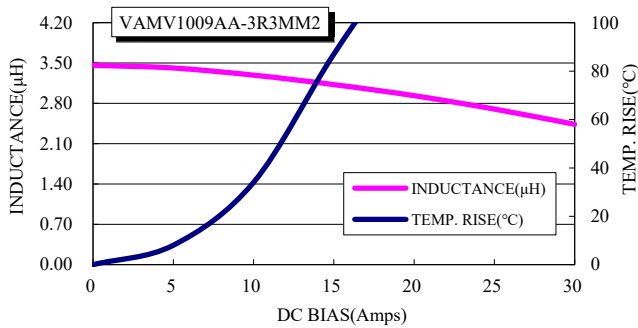
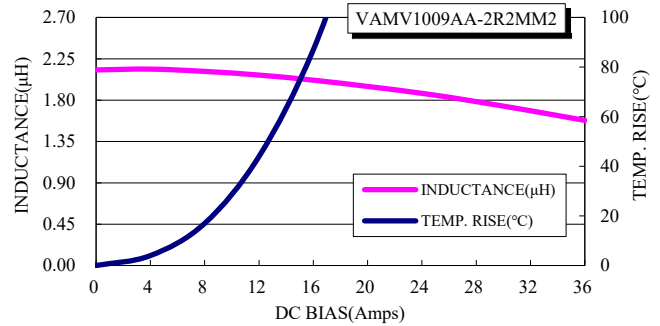
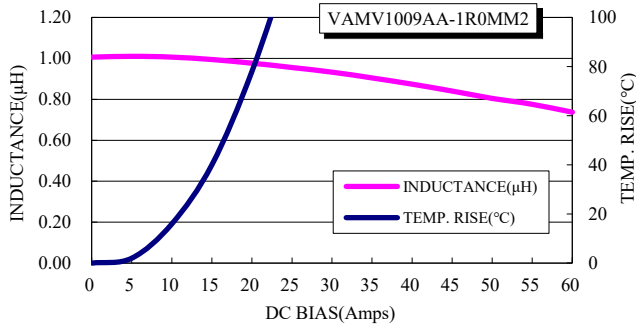

(3) Reel dimensions

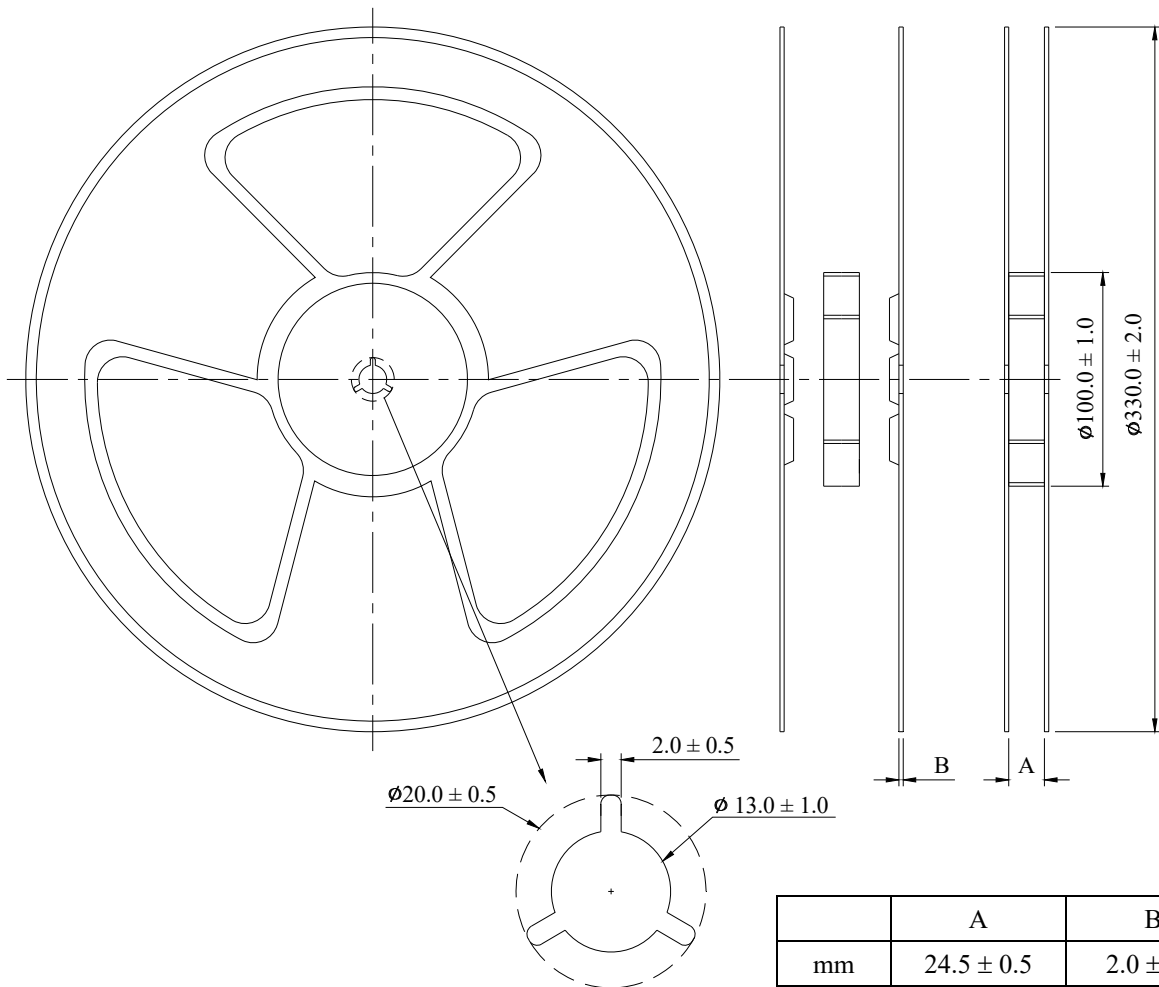

(4) Peel force of top cover tape

The peel speed shall be about 300 mm/minute.

The peel force of top cover tape shall be between 0.1 to 1.3N.

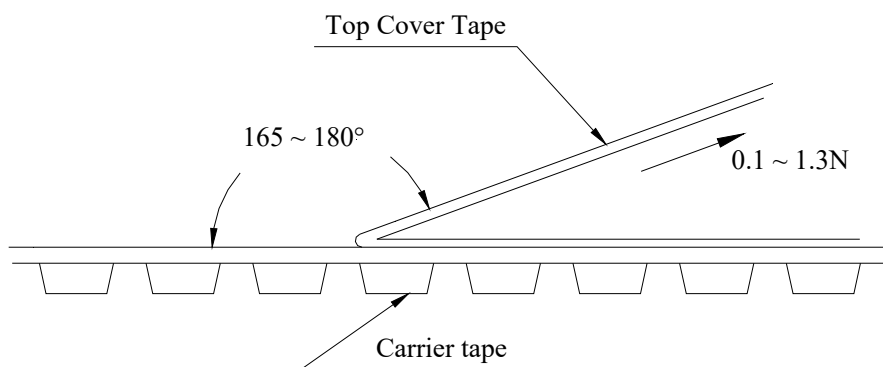

■ Reflow Profile

Power Choke Coil Type

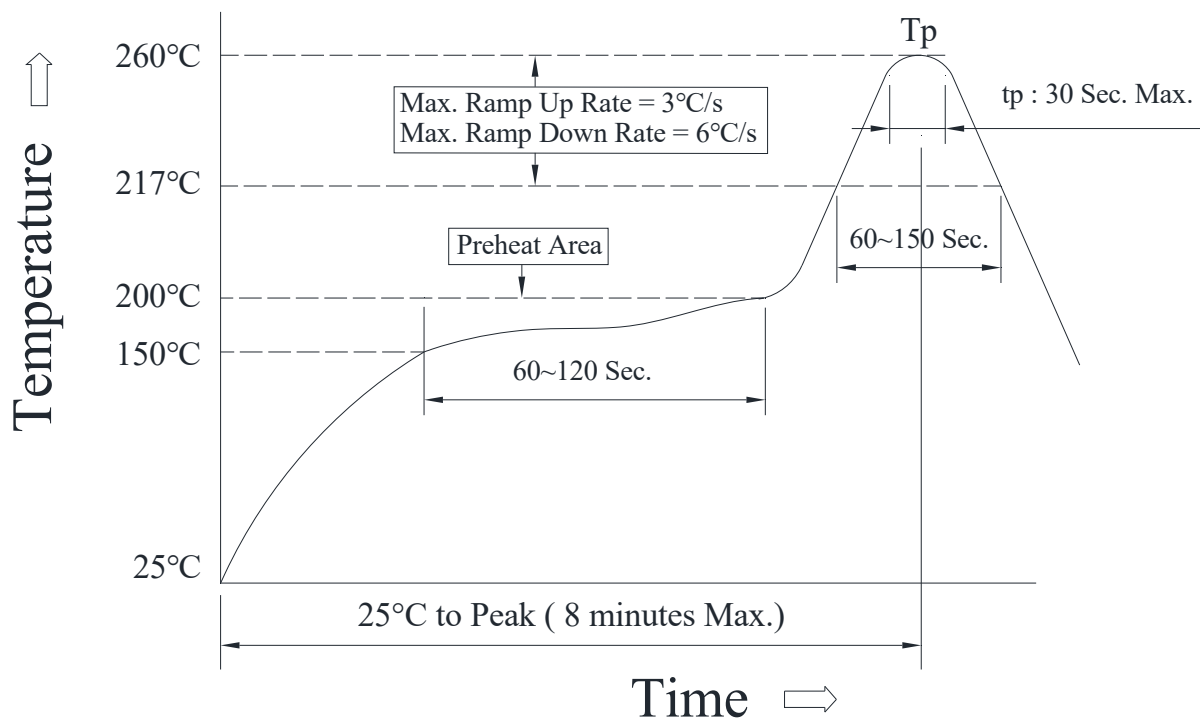

(1) Reflow soldering method :

Reflow Soldering	Tp : 255~260°C	Max. 30 seconds (tp)
	≥ 217°C	60~150 seconds
Preheat	150~200°C	60~120 seconds
Time 25°C to peak temperature	8 minutes Max.	

(2) Soldering iron method : 350 ± 5°C 3 seconds Max.

Mouser Electronics

Authorized Distributor

Click to View Pricing, Inventory, Delivery & Lifecycle Information:

[Cyntec:](#)

[VAMV1009AA-2R2MM2](#) [VAMV1009AA-150MM2](#) [VAMV1009AA-100MM2](#) [VAMV1009AA-3R3MM2](#) [VAMV1009AA-220MM2](#) [VAMV1009AA-5R6MM2](#)