

The history of revision change for the specification

Document	REV.	Modified date	Description
CYNVC-179-005	A0	2017.09.08	New Approval
CYNVC-179-005	A1	2017.09.12	1. Updated the figure of Outline Dimensions 2. Updated the figure of Schematic 3. Updated the figure of Recommend Land Pattern Dimensions
CYNVC-179-005	A2	2017.11.07	1. Sep. -> Nov. 2. Add curve of 100, 150, 470
CYNVC-179-005	A3	2017.12.08	1. Add Packaging 2. Nov. -> Dec.
CYNVC-179-005	A4	2017.12.12	1. Remove Notice "Engineering Sample Only" 2. Update VCSC108T-100MS6K Idc Typ. 5.6->5.3 Max. 5.1->4.8 3. Update VCSC108T-470MS6K Isat Typ. 6.3->6.1 Max. 5.4->5.2
CYNVC-179-005	A5	2018.12.10	1. Dec., 2017 -> Dec., 2018 2. Year code 2017 = 7 -> 2018 = 8 3. Add notice "AEC-Q200 qualified" in Features 4. Remove notice "Preliminary specification" 5. Add "AEC-Q200" logo on page 2 6. Remove spec of 470
CYNVC-179-005	A6	2020.06.15	1. Dec., 2018 -> Jun.,2020 2. Year code 2018 = 8 -> 2020 = 0 3. Add Rated voltage
CYNVC-179-005	A7	2020.06.30	Add Schematic figure
CYNVC-179-005	A8	2021.02.03	1. Jun.,2020 -> Feb.,2021 2. Add spec of 220,470 3. Add curve of 220, 470
CYNVC-179-005	A9	2024.09.26	1. Feb.,2021 -> Sep., 2024 2. Add notice 'Shielded construction' in Features 3. Year code: 2021 = 1 -> 2024 = 4 4. Reflow Soldering : 217°C -> ≥217°C

AEC-Q200

Power Choke Coil VCSC108T MS6K type

■ Features

- High performance (Isat) realized by metal dust core
- Low loss realized with low DCR
- Compliance with RoHS and Halogen Free
- Shielded construction
- AEC-Q200 qualified

■ Application

- Automotive applications
- SEPIC circuit

■ Outline Dimensions

Top view

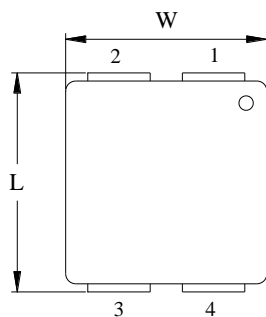

Bottom view

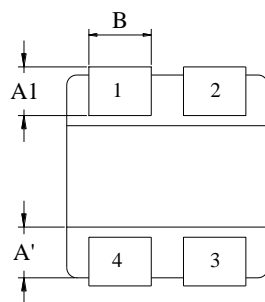

Side view

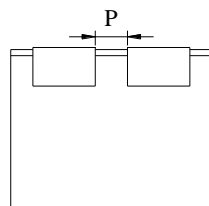
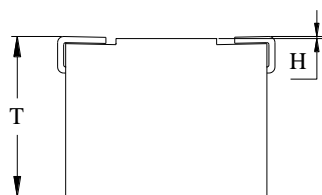

Code	Dimensions (mm)
L	10.80 ± 0.35
W	10.0 ± 0.3
T	8.0 Max.
A1	2.4 ± 0.5
B	3.1 ± 0.3
A'	2.5 ± 0.1
P	1.6 ± 0.2
H	0 ~ +0.15

■ Schematic

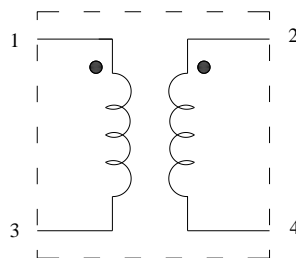
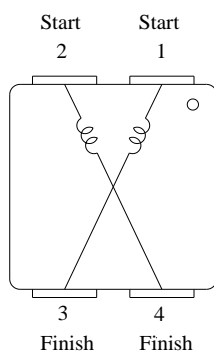

Recommend Land Pattern Dimensions

The customer shall determine the land dimensions shown below after confirming and safety.

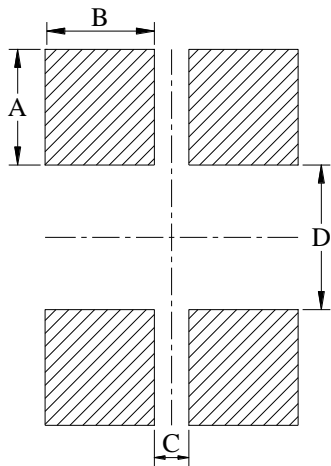

A	4.0
B	3.8
C	1.2
D	5.0

Unit : mm

Marking and Date Code

The little point on the top surface represents winding direction of choke.

(1) Marking

The inductor is marked with a 3-digit code.

Example -- 15.0 μ H → 150

(2) Date code

X XX XXX
 (1) (2) (3)

Where (1) Year code

Ex : 2024 = 4

(2) Weekly code

Serial number : 01 ~ 53

(3) Taping no.

Serial number : 001 ~ ZZZ

Upside of Chip

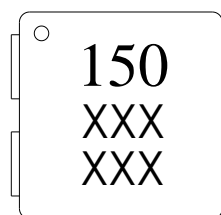

■ Specifications

Part Number	L0 ◇ Inductance (μ H) @ (0A)	R _{dc} (m Ω) ◇		Heat Rating Current DC Amps. Idc (A)		Saturation Current DC Amps. Isat (A)		Rated Voltage (V)	K
		Typical	Maximum	Typical	Maximum	Typical	Maximum	Maximum	
VCSC108T-100MS6K	10	31.0	37.2	5.3	4.8	12.4	10.6	75	> 0.95
VCSC108T-150MS6K	15	39.0	46.8	5.0	4.6	10.6	9.1	75	> 0.95
VCSC108T-220MS6K	22	83.0	99.0	3.4	3.1	8.3	7.1	75	> 0.95
VCSC108T-470MS6K	47	108.0	129.6	2.9	2.6	6.1	5.2	55	> 0.95

◇ : Significant Characteristic

Note 1. : Inductance tolerance \pm 20%

Note 2. : All test data is referenced to 25°C ambient.

Note 3. : Test condition; 100KHz, 1.0Vrms

Note 4. : Idc : DC current (A) that will cause an approximate Δ T of 40°C

Note 5. : Isat : DC current (A) that will cause L0 to drop approximately 30%

Note 6. : K : Coefficient of coupling

Note 7. : Operating temperature range -55°C to +165°C

Note 8. : The part temperature (ambient + temp rise) should not exceed 165°C under the worst case operating conditions. Circuit design, component placement, PCB trace size and thickness, airflow and other cooling provision all affect the part temperature. Part temperature should be verified in the end application.

Note 9. : The rated current as listed is either the saturation current or the heating current depending on which value is lower.

Note 10. : Cleaning process note

(a) If this power choke is dipped in the cleaning agent, such as toluene, xylene, ketone, and ether system, there is a possibility that the performance decreases greatly.

(b) The high power ultrasonic washing may damage the choke body.

(c) Please contact us if you need the cleaning via the above agents or ultrasonic washing.

Note 11. : If you require another part number, please contact with us.

Current Characteristic

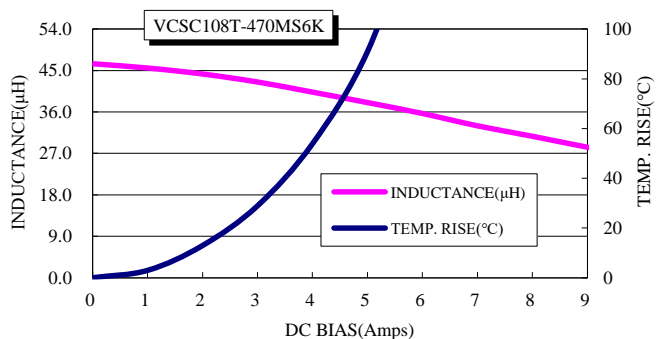
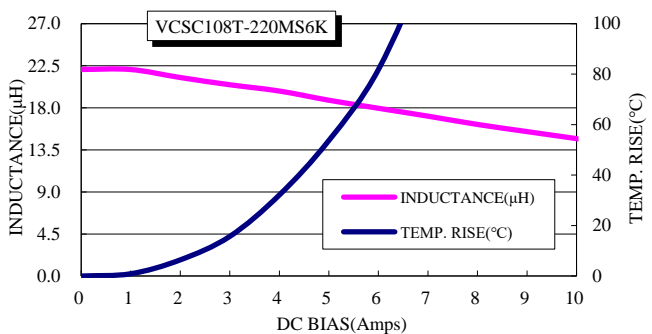
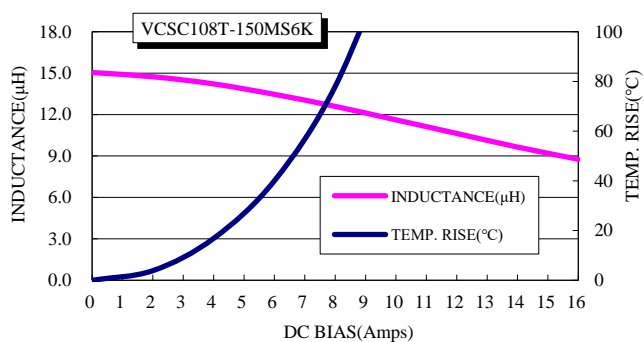
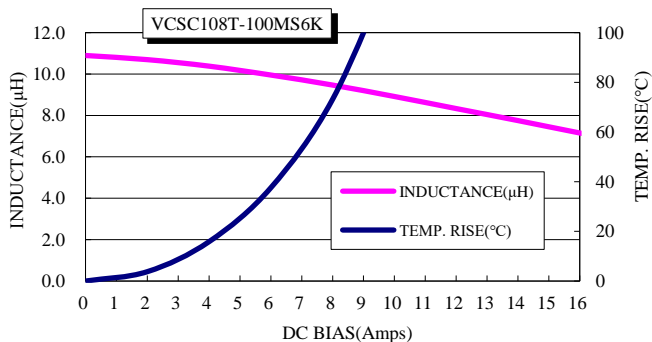

■ Packaging

(1) Tape packaging dimensions

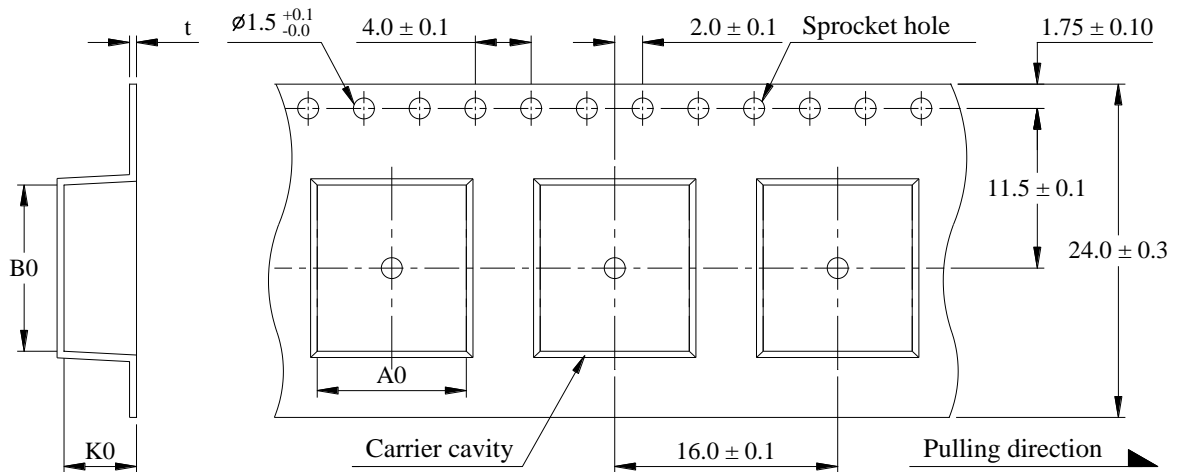

Dimensions Code (mm)				Units/Reel
A0	B0	K0	t	
10.7 ± 0.1	11.65 ± 0.10	8.5 ± 0.1	0.50 ± 0.05	400

(2) Tape direction

The direction shall be seen from the top cover tape side.

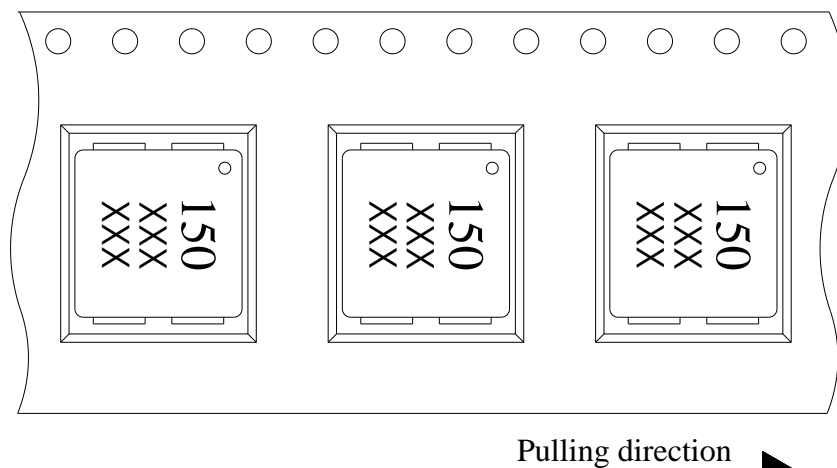

(3) Reel dimensions

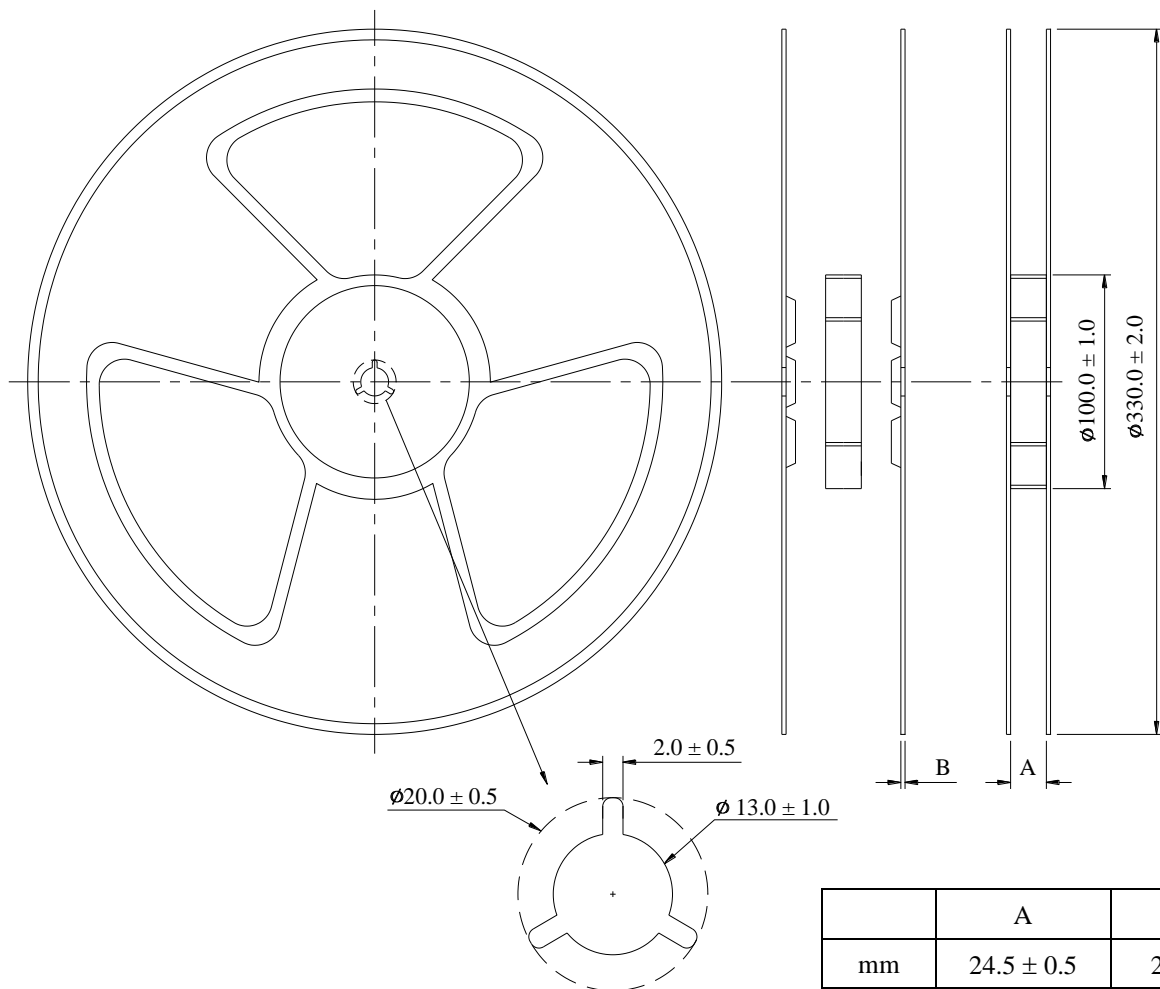

(4) Peel force of top cover tape

The peel speed shall be about 300 mm/minute.

The peel force of top cover tape shall be between 0.1 to 1.3N.

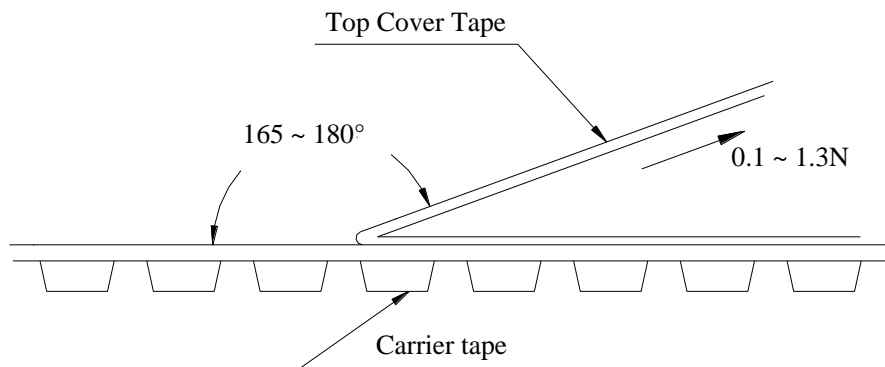

■ Reflow Profile

Power Choke Coil Type

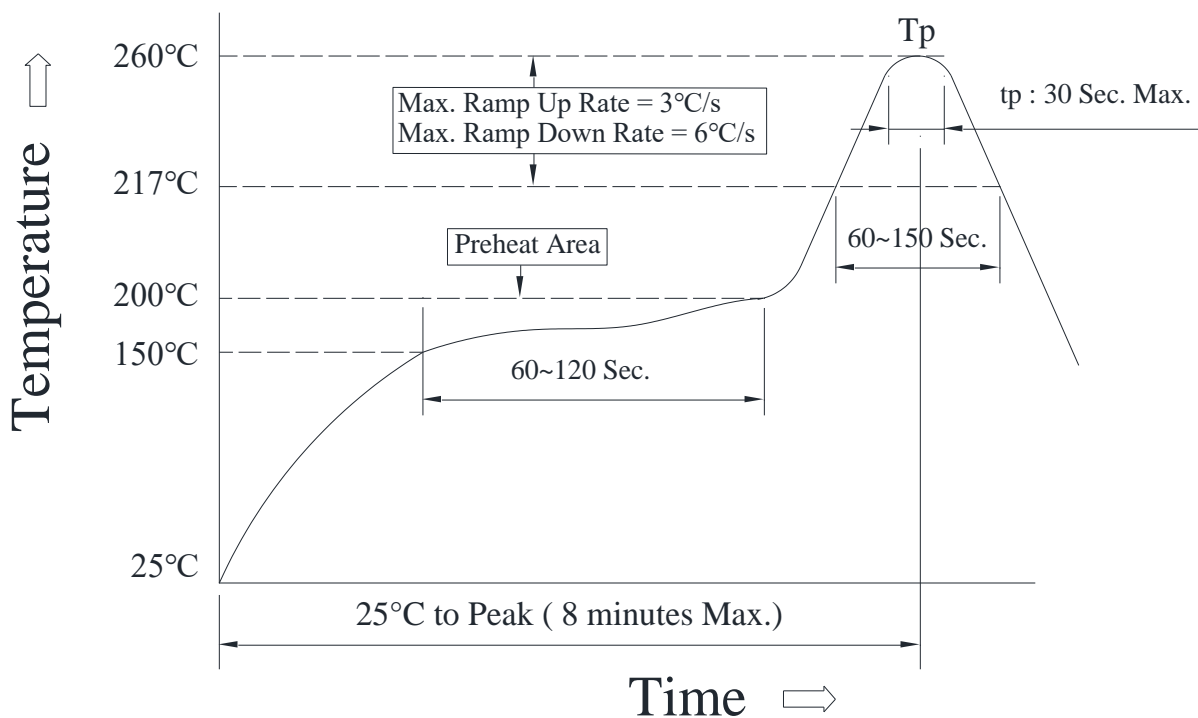

(1) Reflow soldering method :

Reflow Soldering	Tp : 255~260°C	Max. 30 seconds (tp)
	≥ 217°C	60~150 seconds
Preheat	150~200°C	60~120 seconds
Time 25°C to peak temperature	8 minutes Max.	

(2) Soldering iron method : 350 ± 5°C, 3 seconds Max.

Mouser Electronics

Authorized Distributor

Click to View Pricing, Inventory, Delivery & Lifecycle Information:

[Cyntec:](#)

[VCSC108T-100MS6K](#) [VCSC108T-150MS6K](#) [VCSC108T-220MS6K](#) [VCSC108T-470MS6K](#)