

ABCIRP

Connectors

Modular bayonet lock connector series



ABCIRP

Company Profile

TT Electronics' brand AB Connectors specialises in the design, test and manufacture of high performance electronic connectors and interconnect solutions, supplying a range of global customers in aerospace, defence, rail and industrial markets.

Our broad product portfolio which includes miniature connectors, high power connectors, soldier systems, harness assemblies and box systems typically serve within key applications such as signalling, communication and power distribution.



Operating from the principle site in Abercynon, South Wales, our research and development teams have an excellent track record for developing innovative industry solutions and our engineers have extensive experience in designing a range of product configurations to meet customer specific requirements for the most demanding environments.

From plant layout to production line set-up and quick changeover processes, we offer the ideal service, with a flexible manufacturing environment and accredited facilities.

Quality systems and approvals include ISO9001 along with various product and market sector approvals including the military Mil-std 790 and mass transit IRIS certifications and environmental approval to ISO14001. As a result of these qualifications AB Connectors has been awarded several major customer approvals and accreditations.

AB Connectors total commitment to providing customers with high levels of service, cost effectiveness, quality and innovative solutions in interconnection products make it the ideal first choice supply partner.



ABCIRP

Modular Bayonet Lock Connector

The ABCIRP connector series is derived from the American Mil-C-5015 & VG95234 specifications and is approved to the French rail specification NF F 61 030.

The connectors are intermateable and interchangeable with corresponding types, but feature a low fire hazard thermoplastic insulator which is removable for repositioning at an alternative orientation.

Contacts are retained in the insulator by means of a unique beryllium copper spring clip.

Connector sealing features a stepped wire seal grommet which removes the need to populate unused cavities with filler plugs.

Crimp tooling is industry standard and contacts are inserted and removed using simple hand tools.

Benefits include:

- ABCIRP connectors qualified to NF F 61 030 norm.
- Approved for use on railway equipment by SNCF, RATP, Alstom Transport, Bombardier and LUL.
- Compatible with existing MS 5015 reverse bayonet types.
- Low fire hazard / low halogen insulator material tested to French NF F 16-101 norm and BS 6853.
- Cadmium free surface plating. Black Zinc Cobalt, RoHS Compliant.
- Removable insulator.
- Positive location of insulator shell.
- Pin insulators feature with or without bonded resilient rubber face seal.
- Rear individual wire seal grommet with webbed holes.
- Mated connector assemblies sealed to IP67.
- Part populated insulators achieve sealing without the fitting of grommet fillers.
- Contacts retained by high performance metal spring clip.
- Comprehensive range of screened / unscreened, sealed / unsealed backshells & accessories.
- 3D Models available to download from our website.

Conforms to EN45545 HL3 R22/R23 & meets the specifications of the Fire Barrier Testing: EN1363. BS476



Contents

Technical Information	03
Part Number Explanation	05
Basic Assembly	06
Shell Assemblies	07
Insulators	08
Individual Wire Seal Grommet	09
Crimp Contacts	10
Insert Arrangements	12
Insert Arrangement Selector	13
Insulator Orientations	14
Additional Alignment / Polarising Device	15
Panel Mounted Receptacle	16
Plug Connector (style 'T' less accessories)	17
Single Hole Mounting	18
Plug Connector with Protective Rubber Ring (style 'T' less accessories)	19
Locking Backnut for Grommet Sealing only - LBN	20
Straight Conduit Heatshrink Screen Adaptor - SCHSA	21
90° Elbow Conduit Heatshrink Screen Adaptor - ECHSA	22
Shell Heatshrink Extender - SHE	23
Step-Up Adapters - SUA	24
Step-Down Adapters - SDA	25
Cable Gland Adapters	26
Shell Extender with Screening - SPTAS	27
CRA Adapters	28
Waterproof Clamp for Jacketed Clamp	29
Cable Clamp	30
Telescopic Brushing (use with CMSP 3057A clamp)	31
Panel Gasket	32
Connector Fixing Nut Plates / Grommet Fillers	33
Receptacle Mounting Detail	34
Metal Protective Caps	35
RFI Braid Sock, Bandit Strap & Knitmesh Braid	36
Crimp Contacts - Tooling	37
Crimp Contacts - Supplementary Tooling	38
Safety Information	39

ABCIRP

technical information

Materials

Shell:	Aluminium Alloy
Insulator:	Low fire hazard thermoplastic qualified to NFF 16101 and to meet BS 6853 Conforms to EN45545 HL3 R22/R23
Grommet & bushing:	Low fire hazard rubber tested to NFF 16101 norm and to meet BS 6853 Conforms to EN45545 HL3 R22/R23
Contacts:	Copper alloy
Contact retaining clip:	Beryllium copper
Accessory hardware:	Aluminium alloy

Standard Plating Finishes

Aluminium parts:	Black chromate over zinc cobalt, RoHS compliant
Contacts:	Gold over silver #16 and #12 Silver #8

* Consult factory for alternative finishes

Environmental Ratings

Operating temperature range:	-55°C to +125°C
Shock severity:	75g
Vibration:	5-500Hz long endurance. 30 hours at 10g
Acceleration:	50g

Mechanical Features

Coupling:	3 pin reverse bayonet. 120° coupling nut rotation
Number of contacts:	7 to 60
Contact termination:	Crimp & PCB
Minimum retention force of the contact in the insulator:	Beryllium copper spring clip 70N for contacts #16 (1.6 mm) 90N for contacts #12 (2.4 mm) 110N for contacts #8 (3.6 mm)
Sealing:	IP67 rated when connectors are mated and used with appropriate sealed backshell
Matings:	2000 minimum mating and unmating
Max Coupling Torque:	8NM

ABCIRP receptacle connectors feature stainless steel pins at critical wear points of the cam tracks. This feature is incorporated to protect against excessive wear inflicted by continuous mating / de-mating and heavy vibration.

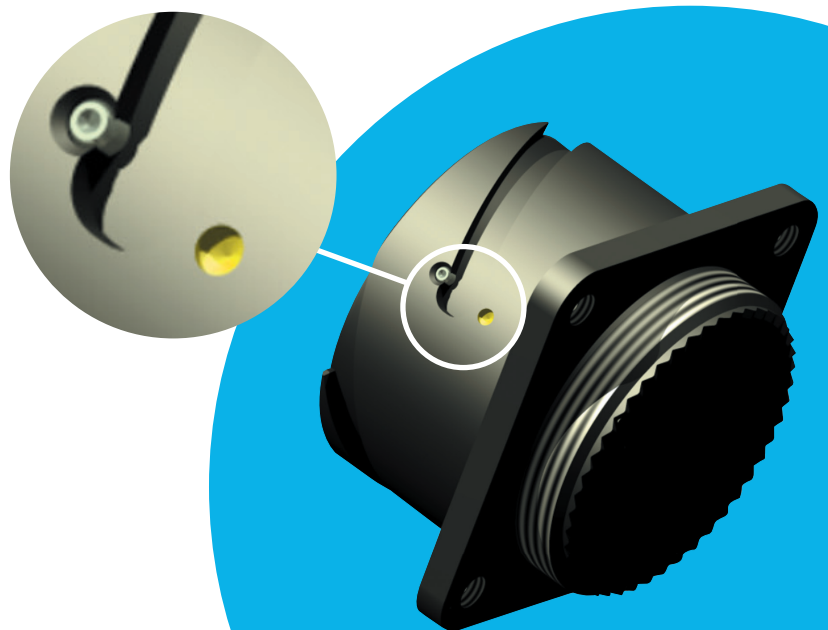

ABCIRP

Technical information

Contact Size AWG	*Maximum Current @ 20°C	* Rated Current @ 85°C	** De-rated Current @ 85°C
16	22A	13A	10A
12	41A	23A	20A
8	73A	46A	42A

* Single contact in isolation

** Grouped contacts

Contact Arrangement Service Rating

Service Rating	Sea Level	
	A	D
Working voltage DC or AC Peak	700 V	1,250 V
Voltage Proof AC RMS	2,000 V	2,800 V
Minimum Flashover AC RMS	2,800 V	3,600 V

Contact Arrangement Service Rating

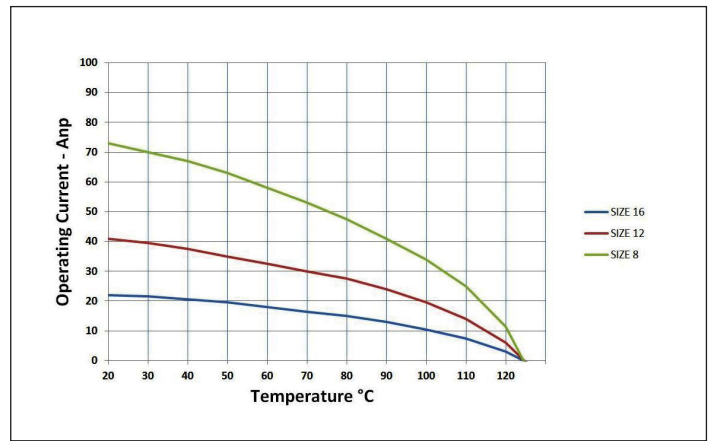

ABCIRP

ABCIRP

Part number explanation

AB-CIRP	03	LBN	22	14	GPS	P	FS	****	VO	N
Series Prefix	Shell Style	Accessory Type	Shell Size	Contact Arrangement	Grommet Type	Contact Type P=Pin S=Socket	Face Seal	Modification Code	Contact Supply	Insulator Orientation

Series Prefix:	ABCIRP	
Shell Style:	03	4 Hole Square flange receptacle, rear panel mounted.
	SE06	Plug with RFI grounding
	09	Single hole mounted receptacle
	PSE06T	Plug with RFI grounding and rubber covered coupling nut
Accessory Type:	A	No rear threads and no accommodation for accessories Shell styles 03
	T	Rear threads for accessory accommodation
	LBN	Locking Back Nut
	SCHSA	Straight Conduit Heatshrink Adaptor
	ECHSA	90° Conduit Heatshrink Adaptor
	SHE#	Shell Extender M - Metric thread P - PG thread
	SUA#	Step up adapter M - Metric thread P - PG thread
	SDA#	Step down adapter M - Metric thread P - PG thread
Shell Size:	18 - 40	
Contact Arrangement:	See page 12	
Grommet Type:	As there is a choice of Wire Seal Grommet to suit varying cable diameters, this component may be omitted from the part number and ordered as a separate item if required. Refer to page 9 for details.	
Contact Type:	P = Pin S = Socket	
Face Seal:	Pin insulator only. When face seal is required, add 'FS' to part number.	
Modification Code:	Issued for connector with non-standard feature. Consult factory for detail. M6 - Tapped mounting holes.	
Contact Supply:	Leave blank for connectors supplied with silver contacts Add 'P3' for gold contacts. Add 'V0' for connectors supplied without contacts.	
Insulator Orientation:	Leave blank for connectors supplied in sub-assembly form. Add applicable orientation letter (see page 14) if connectors are to be supplied factory assembled.	

ABCIRP

basic assembly

Rear Panel Mounted Connector - Basic Assembly



Plug Connector - Basic Assembly



ABCIRP

ABCIRP

shell assemblies

Rear Mounting Fixed Receptacle

Shell Size	Part Number Rear Mount
18	ABCIRP18XR
20	ABCIRP20XR
22	ABCIRP22XR
24	ABCIRP24XR
28	ABCIRP28XR
32	ABCIRP32XR
36	ABCIRP36XR
40	ABCIRP40XR



Plug Connector - Basic Assembly

Shell Size	Part Number
18	ABCIRPSE18FS
20	ABCIRPSE20FS
22	ABCIRPSE22FS
24	ABCIRPSE24FS
28	ABCIRPSE28FS
32	ABCIRPSE32FS
36	ABCIRPSE36FS
40	ABCIRPSE40FS

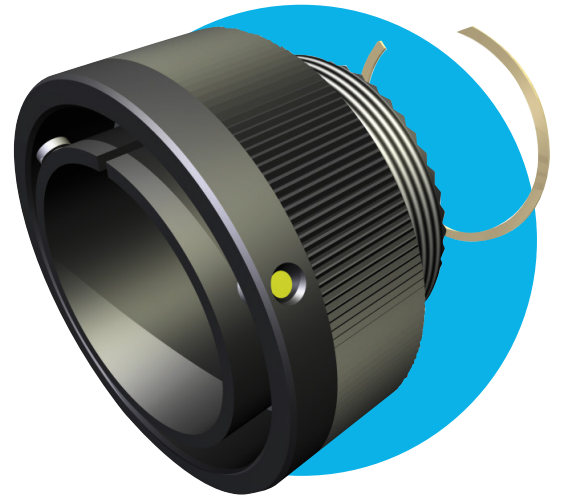

Free plug assembly with EMI/RFI Grounding

Note: Both the fixed and free shell assembly is supplied with an insulator retaining circlip.

ABCIRP

insulators

Pin Insulator with Face Seal

Delete 'FS' if seal is not required

Shell Size	Contact Arrangement	Part Number
18	18-19	ABCIRP18-19PFS
20	20-15	ABCIRP20-15PFS
22	22-14	ABCIRP22-14PFS
24	24-10	ABCIRP24-10PFS
28	28-21	ABCIRP28-21PFS
32	32-A13	ABCIRP32-A13PFS
36	36-A22	ABCIRP36-A22PFS
40	40-A35	ABCIRP40-A35PFS
40	40-A60	ABCIRP40-A60PFS



Socket Insulator

Shell Size	Contact Arrangement	Part Number
18	18-19	ABCIRP18-19S
20	20-15	ABCIRP20-15S
22	22-14	ABCIRP22-14S
24	24-10	ABCIRP24-10S
28	28-21	ABCIRP28-21S
32	32-A13	ABCIRP32-A13S
36	36-A22	ABCIRP36-A22S
40	40-A35	ABCIRP40-A35S
40	40-A60	ABCIRP40-A60S

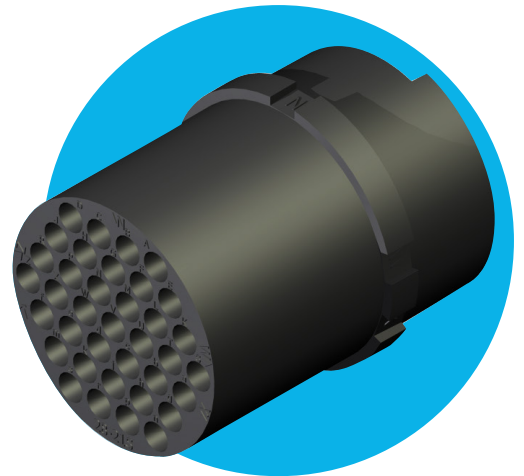

Insulator Retaining Ring

Shell Size	Part Number
18	ABCIRP18IC
20	ABCIRP20IC
22	ABCIRP22IC
24	ABCIRP24IC
28	ABCIRP28IC
32	ABCIRP32IC
36	ABCIRP36IC
40	ABCIRP40IC

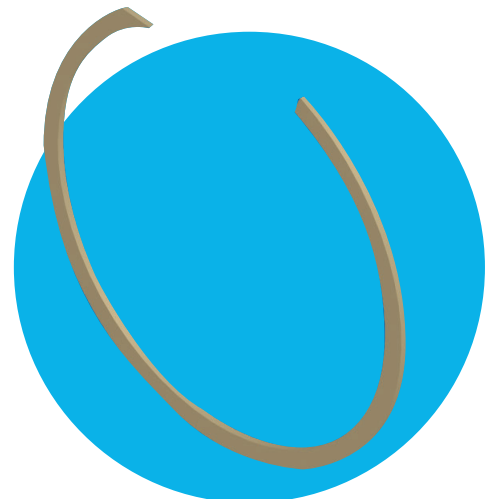

ABCIRP

ABCIRP

individual wire seal grommet



Individual Wire Seal Grommets - Size 16

Grommet Type	Contact Arrangement	Wire Insulation Min O/D mm	Wire Insulation Max O/D mm	Part Number
Pin, Small Bore	18-19	0.8	2.30	ABCIRP18-19GPS
	22-14			ABCIRP22-14GPS
	28-21			ABCIRP28-21GPS
	40-A60			ABCIRP40-A60GPS
Socket, Small Bore	18-19	0.8	2.30	ABCIRP18-19GSS
	22-14			ABCIRP22-14GSS
	28-21			ABCIRP28-21GSS
	40-A60			ABCIRP40-A60GSS
Pin, Large Bore	18-19	1.5	3.30	ABCIRP18-19GPL
	22-14			ABCIRP22-14GPL
	28-21			ABCIRP28-21GPL
	40-A60			ABCIRP40-A60GPL
Socket, Large Bore	18-19	1.5	3.30	ABCIRP18-19GSL
	22-14			ABCIRP22-14GSL
	28-21			ABCIRP28-21GSL
	40-A60			ABCIRP40-A60GSL

Individual Wire Seal Grommets - Size 12 Contacts

Grommet Type	Contact Arrangement	Wire Insulation Min O/D mm	Wire Insulation Max O/D mm	Part Number
Pin, Small Bore	20-15	0.8	2.30	ABCIRP20-15GPS
	32-A13			ABCIRP32-A13GPS
	36-A22			ABCIRP36-A22GPS
	40-A35			ABCIRP40-A35GPS
Socket, Small Bore	20-15	0.8	2.30	ABCIRP20-15GSS
	32-A13			ABCIRP32-A13GSS
	36-A22			ABCIRP36-A22GSS
	40-A35			ABCIRP40-A35GSS
Pin, Large Bore	20-15	2.35	5.20	ABCIRP20-15GPL
	32-A13			ABCIRP32-A13GPL
	36-A22			ABCIRP36-A22GPL
	40-A35			ABCIRP40-A35GPL
Socket, Large Bore	20-15	2.35	5.20	ABCIRP20-15GSL
	32-A13			ABCIRP32-A13GSL
	36-A22			ABCIRP36-A22GSL
	40-A35			ABCIRP40-A35GSL

Individual Wire Seal Grommets - Size 8 Contacts

Grommet Type	Contact Arrangement	Wire Insulation Min O/D mm	Wire Insulation Max O/D mm	Part Number
Pin, Small Bore	24-10	1.86	4.90	ABCIRP24-10GPS
Socket, Small Bore				ABCIRP24-10GSS
Pin, Large Bore		3.00	7.20	ABCIRP24-10GPL
Socket, Large Bore				ABCIRP24-10GSL

ABCIRP

pin crimp contacts

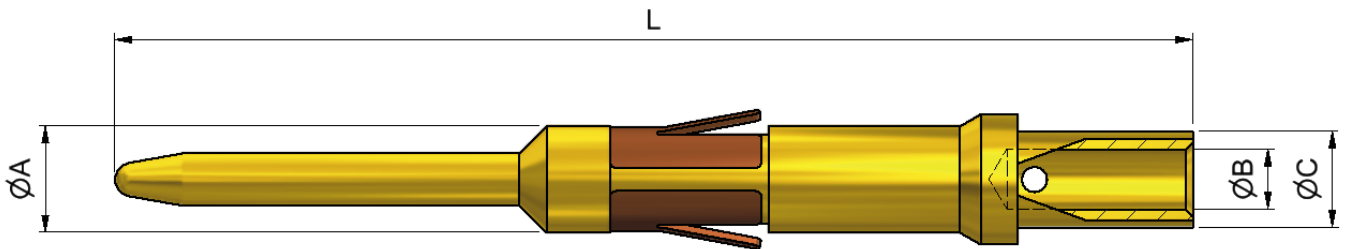
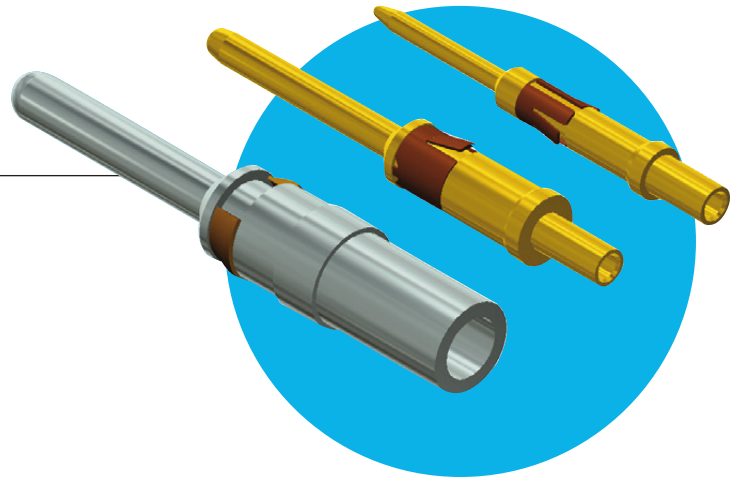

Contact Size AWG	Part Number	A	B	C	Conductor CSA mm ²	L
ABCIRP**/**KPKP3						
16/22	16/22	3.20	0.90	2.30	0.25/0.34	31.75
16/20	16/20		1.10	2.65	0.50/0.60	
16/18	16/18		1.25	2.30	0.75/0.93	
16	16		1.75	2.75	0.93/1.50	
16/14	16/14		1.80	2.90	1.68	
ABCIRP**/**KPKP3						
12/20	12/20	4.80	1.10	2.65	0.50/0.60	37.50
12/18	12/18		1.25	2.30	0.75/0.93	
12/16	12/16		1.75	2.75	0.93/1.50	
12/14	12/14		1.80	2.90	1.68	
12	12		2.50	3.80	2.50/3.00	
12/10	12/10		3.00	4.00	5.53	
12/(40)	12/40		2.70	4.00	4.00	
ABBP**/**KPKP80						
8/16	8/16	7.80	1.75	2.75	0.93/1.50	42.40
8/(40)	8/40		2.90	5.20	4.00	
8/12	8/12		2.50	3.80	2.50	
8	8		4.55	6.80	9.00	
(100)	100		4.40	7.00	10.00	
(100/60)	100/60		3.40	5.50	6.00	

() = metric

Notes: Standard plating for size 16 & 12 contacts is gold.
 Remove P3 from part numbers above for silver plated contacts.
 Standard plating for size 8 & 100 contacts is silver.
 Add P3 to part numbers above for gold plated contacts.

ABCIRP

ABCIRP

socket crimp contacts

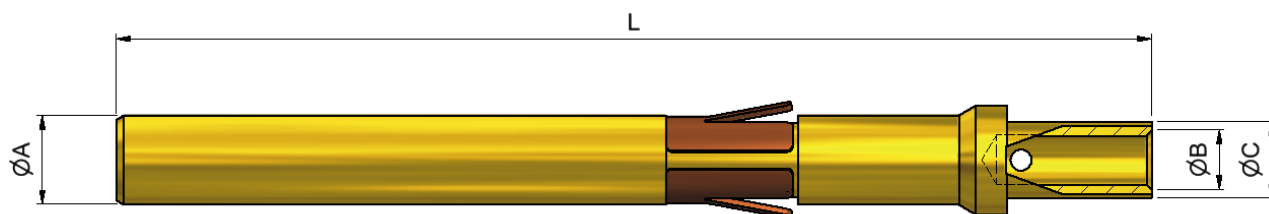
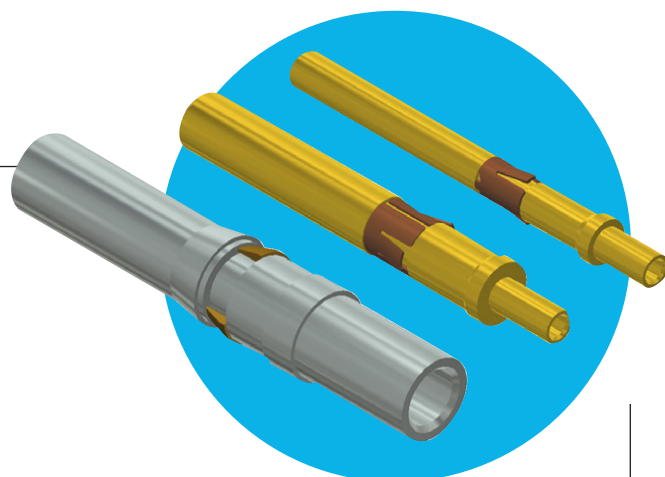

Contact Size AWG	Part Number	A	B	C	Conductor CSA mm ²	L
ABCIRP**/**KLKP3						
16/22	16/22	3.20	0.90	2.30	0.25/0.34	36.50
16/20	16/20		1.10	2.65	0.50/0.60	
16/18	16/18		1.25	2.30	0.75/0.93	
16	16		1.75	2.75	0.93/1.50	
16/14	16/14		1.80	2.90	1.68	
ABCIRP**/**KLKP3						
12/20	12/20	4.80	1.10	2.65	0.50/0.60	37.50
12/18	12/18		1.25	2.30	0.75/0.93	
12/16	12/16		1.75	2.75	0.93/1.50	
12/14	12/14		1.80	2.90	1.68	
12	12		2.50	3.80	2.50/3.00	
12/10	12/10		3.00	4.00	5.53	
12/(40)	12/40		2.70	4.00	4.00	
ABBP**/**KSKP80						
8/16	8/16	7.80	1.75	2.75	0.93/1.50	41.20
8/(40)	8/40		2.90	5.20	4.00	
8/12	8/12		2.50	3.80	2.50	
8	8		4.55	6.80	9.00	
(100)	100		4.40	7.00	10.00	
(100/60)	100/60		3.40	5.50	6.00	

() = metric

Notes: Standard plating for size 16 & 12 contacts is gold.
Remove P3 from part numbers above for silver plated contacts.
Standard plating for size 8 & 100 contacts is silver.
Add P3 to part numbers above for gold plated contacts.

ABCIRP

insert arrangements

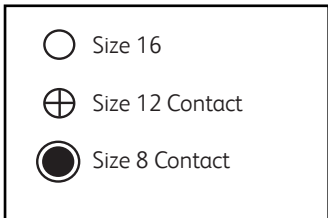

7 Contacts

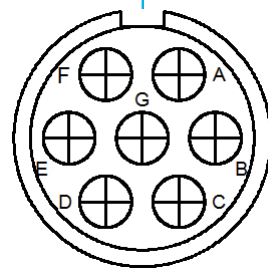

20-15
Service A
7 Contacts,
Size #12 (25)

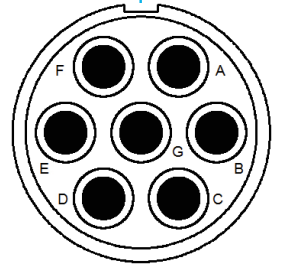

24-10
Service A
7 Contacts,
Size #8 (100)

10 Contacts

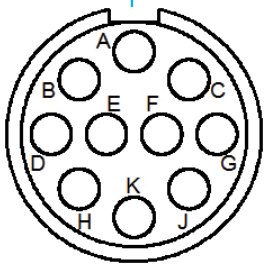

18-19
Service A
10 Contacts,
Size #16 (15)

13 Contacts

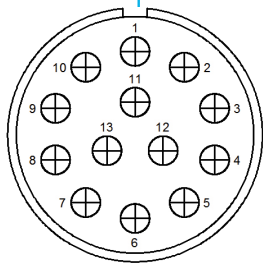

32-A13
Service D
13 Contacts,
Size #12 (25)

19 Contacts

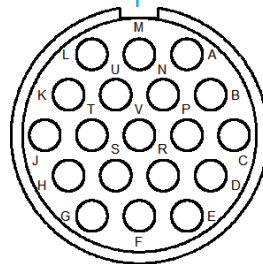

22-14
Service A
19 Contacts,
Size #16 (15)

22 Contacts

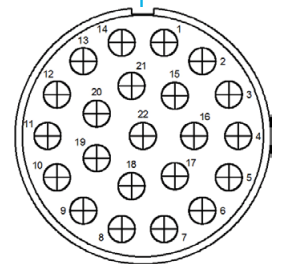

36-A22
Service D
22 Contacts,
Size #12 (25)

35 Contacts

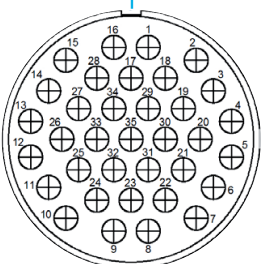

40-A35
Service D
35 Contacts,
Size #12 (25)

37 Contacts

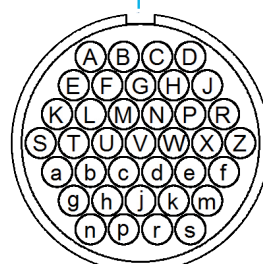

28-21
Service A
37 Contacts,
Size #16 (15)

60 Contacts

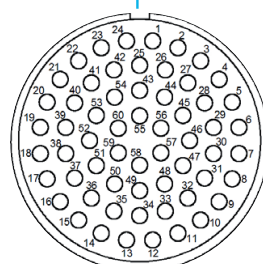

40-A60
Service A
60 Contacts,
Size #16 (15)

ABCIRP

insulator orientations

Position of orientation identifier on insulator moulding

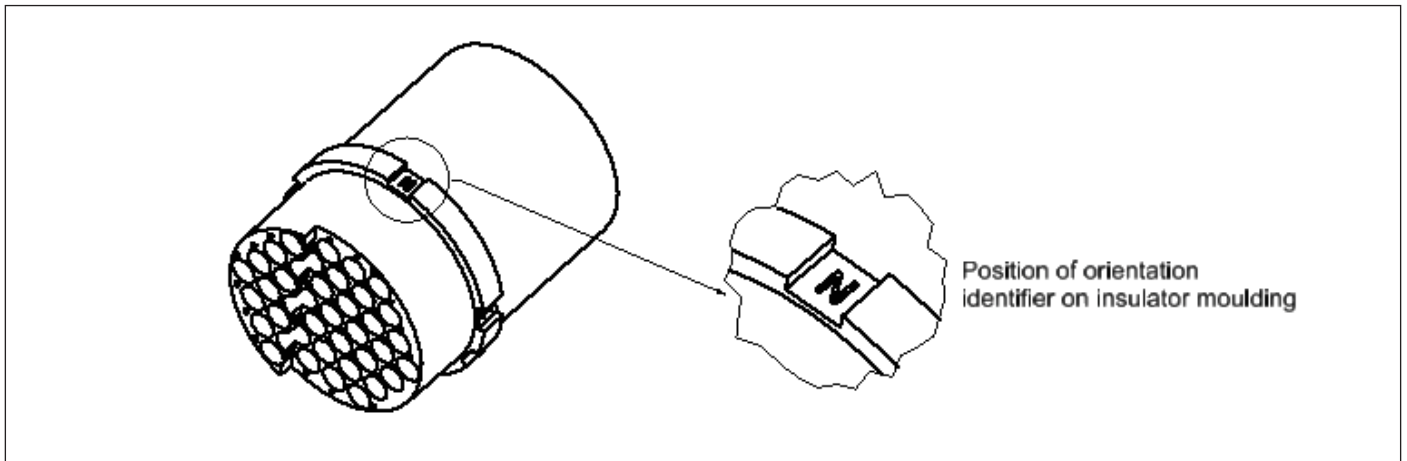

Position of orientation identifier on insulator moulding

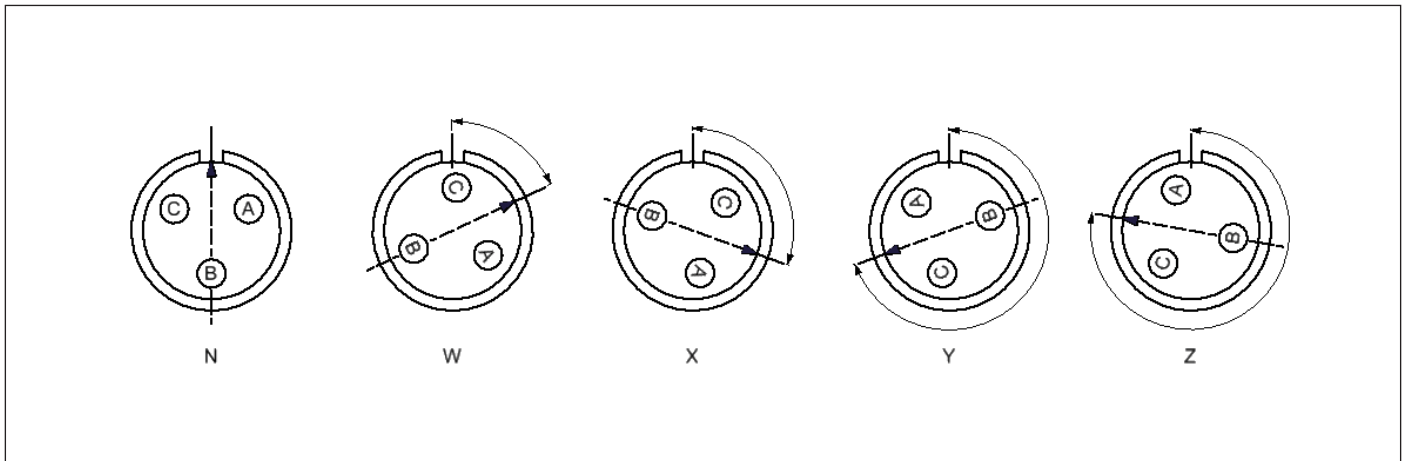

Contact Arrangement	Angular Displacement of Inserts				
	N YELLOW	W BLUE	X GREEN	Y PURPLE	Z WHITE
18-19	0	-	120	240	-
20-15		80	-	-	280
22-14			110	250	
24-10			-	-	
28-21		110	250		
32-A13		65	130	230	295
36-A22		80	110	250	280
40-A35		70	130	230	290
40-A60		80	110	250	280

ABCIRP

ABCIRP

additional alignment / polarising device

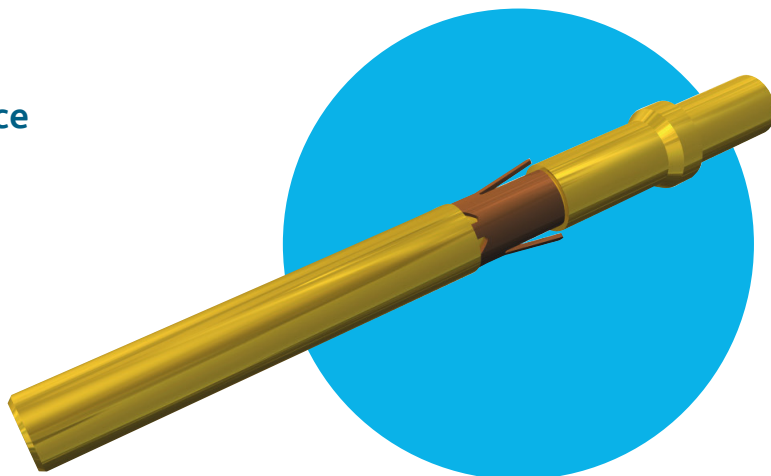

Contact Arrangement	Insulator Orientation	Alignment / Polarising Pin Position
18-19	ALL	Any one hole
20-15		Any one hole apart from G
22-14		Holes K & R
24-10		Any one hole apart from G
28-21		Holes E & e
32-A13		Hole 10
36-A22		Holes 14 & 17
40-A35		Holes 1 & 24
40-A60		N
	W, X, Y & Z	Holes 26 & 59

How to Order:

ABCIRP ** FAP

** Contact Size

Note: Consult factory for all other positions.

ABCIRP

rear panel mounted receptacle



ABCIRP03T

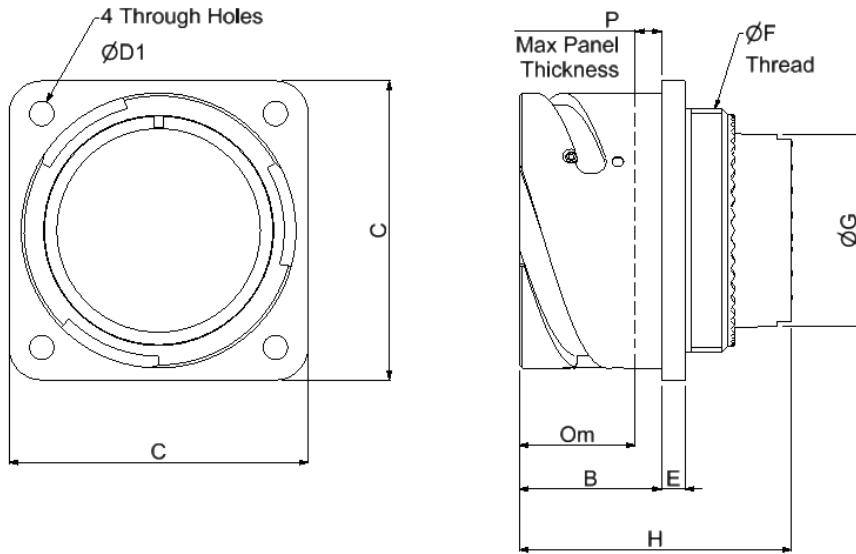

Shell Size	ØF Thread Class 2A	B Max	C Max	Ød1 +0,2-0	Threaded Holes (MOD CODE M6)	E Max	ØG	H	P see note	Om Min Overlap Mated
18	1" x 20 UNEF	23.45	35.30	3.20	M4	4.20	18.30	46.25	3.30	15.85
20	1½" x 18 UNEF		38.30				20.50			
22	1¾" x 18 UNEF		41.30				24.60			
24	1¾" x 18 UNEF	24.45	44.80	3.70	M5	4.20	27.00	46.25	3.30	15.75
28	1¾" x 18 UNEF		51.10				32.50			
32	1¾" x 16 UN		57.30	35.80						
36	2¼" x 16 UNS		63.80	42.50						
40	2¼" x 16 UN		70.20	4.30			48.50			

Note: Maximum panel thickness when using cap head screws.
When using countersunk screws, maximum panel thickness = 7.5mm.

See page 34 for panel mounting details

ABCIRP

ABCIRP

plug connector (style 'T' less accessories)



ABCIRPSE06T

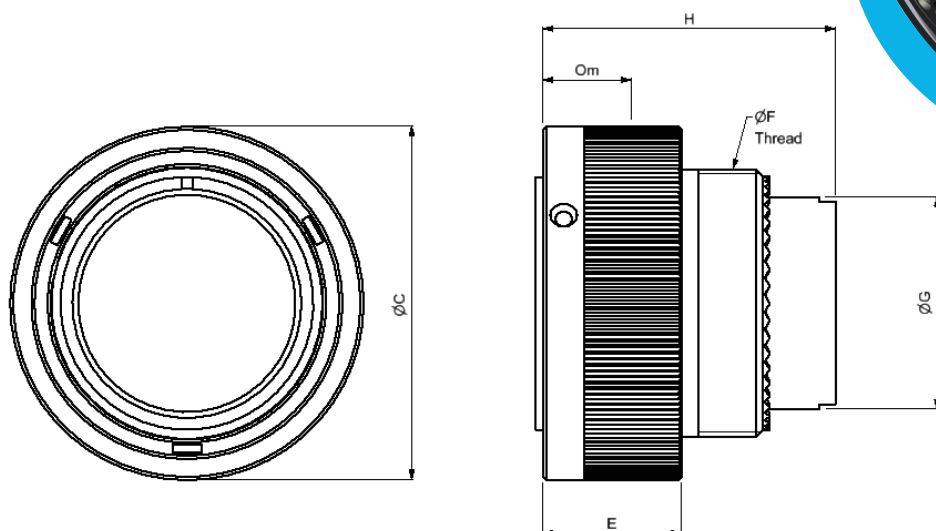

Shell Size	C Max	E Max	$\varnothing F$ Thread Class 2A	$\varnothing G$	H	Om Min Over- lap Mated
18	37.30	24.00	1'' x 20 UNEF	18.30	46.25	15.85
20	40.70		1 $\frac{1}{8}$ '' x 18 UNEF	20.50		
22	44.20		1 $\frac{1}{4}$ '' x 18 UNEF	24.60		
24	47.70		1 $\frac{3}{8}$ '' x 18 UNEF	27.00		
28	54.50	27.00	1 $\frac{1}{2}$ '' x 18 UNEF	32.50		15.75
32	61.40		1 $\frac{5}{8}$ '' x 16 UN	35.80		
36	68.00		2 $\frac{1}{16}$ '' x 16 UNS	42.50		
40	74.00		2 $\frac{5}{16}$ '' x 16 UN	48.50		

Note: All plug connectors are EMI/RFI versions.

ABCIRP

single hole mounting receptacle

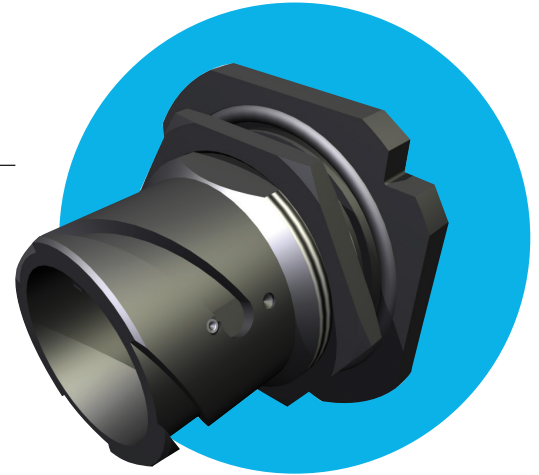

ABCIRP09T

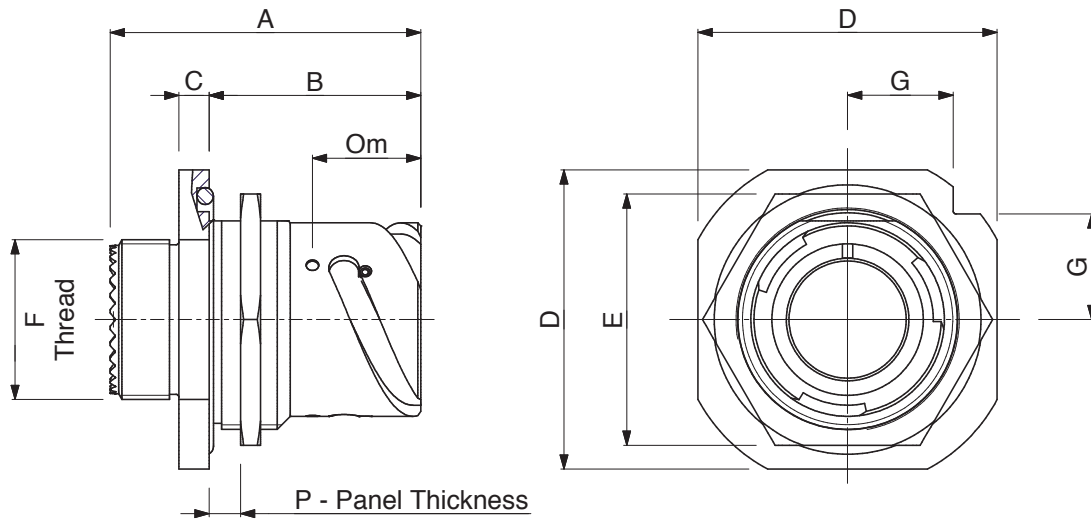

Shell Size	A Max	B	C	D Max	E	ØF Thread Class 2A	ØG	P		Om Min Overlap Mated
								Min	Max	
18	49.55	33.70	4.80	47.85	39.70	1'' x 20 UNEF	16.80	2.40	9.00	15.85
20				51.05	44.00	1 ¹ / ₈ '' x 18 UNEF	18.00			
22				54.45	46.00	1 ¹ / ₄ '' x 18 UNEF	20.20		9.10	
24				57.45	50.80	1 ³ / ₈ '' x 18 UNEF	20.20			
28	52.15	35.20	5.60	63.75	55.00	1 ⁵ / ₈ '' x 18 UNEF	22.50		8.50	15.75
32				70.05	62.00	1 ⁷ / ₈ '' x 18 UNEF	24.70			
36				76.45	71.00	2 ¹ / ₁₆ '' x 18 UNS	26.90		8.30	
40				83.75	75.00	2 ⁵ / ₁₆ '' x 18 UN	29.60			

ABCIRP

ABCIRP

plug connector with protective rubber ring
(style 'T' less accessories)

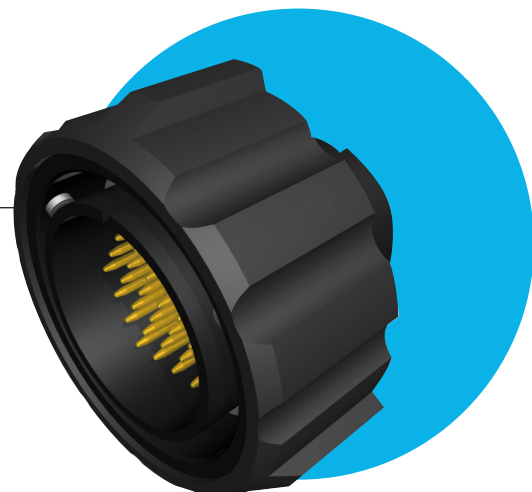

ABCIRPPSE06T

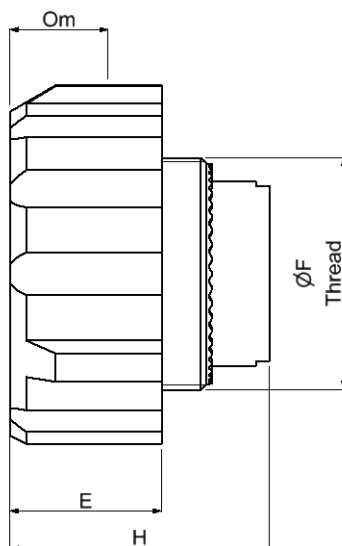
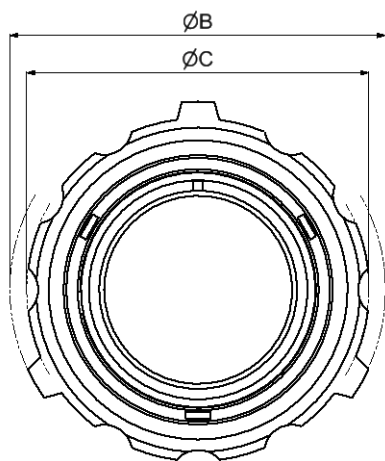

Shell Size	B Max	C Max	E Max	ØF Thread Class 2A	H Max	Om Min Overlap Mated
18	49.00	43.50	27.10	1'' x 20 UNEF	46.82	17.85
20	51.50	46.00		1½'' x 18 UNEF		
22	56.00	50.50		1¼'' x 18 UNEF		
24	60.00	54.00		1⅝'' x 18 UNEF		
28	67.00	61.00		1⅝'' x 18 UNEF		17.75
32	76.00	67.60		1⅝'' x 16 UN		
36	82.30	74.30		2¼'' x 16 UNS		
40	88.00	80.00		2⅝'' x 16 UN		

Note: All plug connectors are EMI/RFI versions.

ABCIRP

locking backnut for grommet sealing only
LBN (locking)

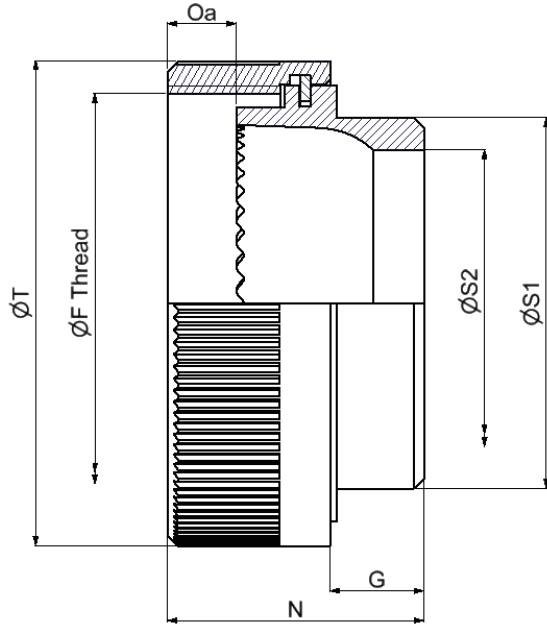
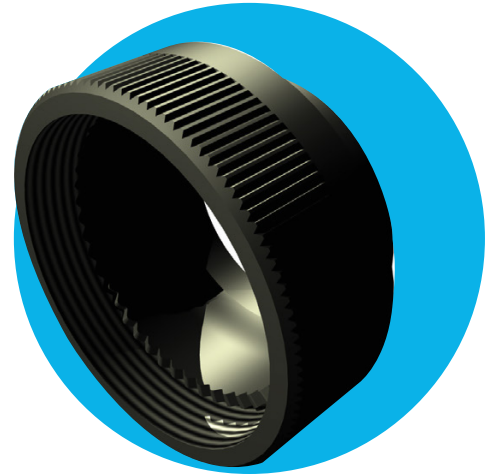

Shell Size	ØF Thread Class 2B	G Max	N Max	ØS1 Max	ØS2 Min	ØT Max	Oa Min Overlap Accessory
18	1" x 20 UNEF	8.70	25.65	25.50	16.70	31.00	7.00
20	1 1/8" x 18 UNEF			30.20	19.80	35.00	
22	1 1/4" x 18 UNEF					38.00	
24	1 3/8" x 18 UNEF		24.65	36.60	25.40	41.00	
28	1 5/8" x 18 UNEF				27.00	48.00	
32	1 7/8" x 16 UN			44.50	32.50	54.00	
36	2 1/16" x 16 UNS			50.90	35.70	61.00	
40	2 5/16" x 16 UN			57.20	45.00	67.00	

How to Order:

ABBP ** LBN

** Shell Size

ABCIRP

ABCIRP

straight conduit heatshrink screen adapter
SCHSA (locking)

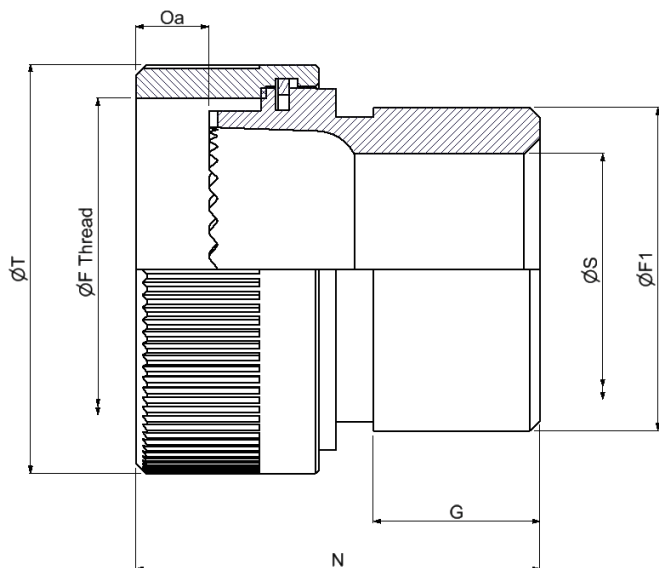
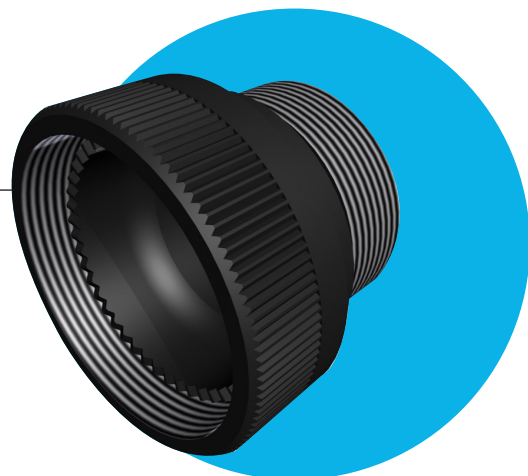

Shell Size	ØF Thread Class 2B	ØF1 Thread Class 2A	G Max	N Max	ØS Min	ØT Max	Oa Min Overlap Accessory
18	1'' x 20 UNEF	1'' x 20 UNEF	12.40	36.06	16.70	31.00	7.00
20	1 1/8'' x 18 UNEF	1 3/16'' x 18 UNEF		38.60	19.80	35.00	
22	1 1/4'' UNEF				21.34	38.00	
24	1 3/8'' x 18 UNEF	1 1/2'' x 18 UNEF		38.56	25.40	41.00	
28	1 5/8'' x 18 UNEF				30.13	48.00	
32	1 7/8'' x 16 UN	1 3/4'' x 18 UNS	12.10	38.26	36.73	54.00	
36	2 1/16'' x 16 UNS	2'' x 18 UNS		39.26	41.00	61.00	
40	2 3/16'' x 16 UN	2 1/4'' x 16 UN		38.30	48.10	67.00	

How to Order:
 ABBP ** SCHSA
 ** Shell Size

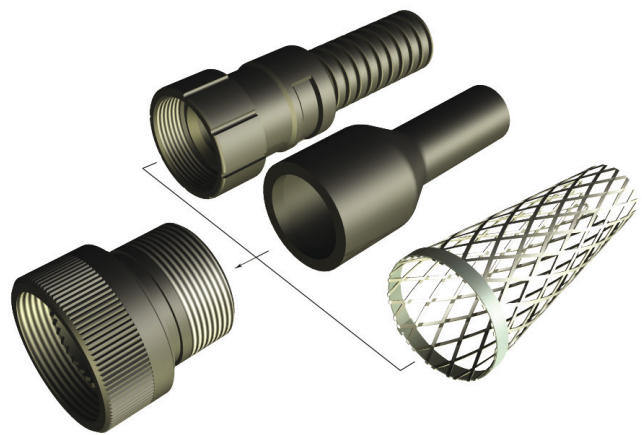

Thread measurement is imperial, all other measurements in mm.

ABCIRP

90° elbow conduit heatshrink screen adapter ECHSA (locking)

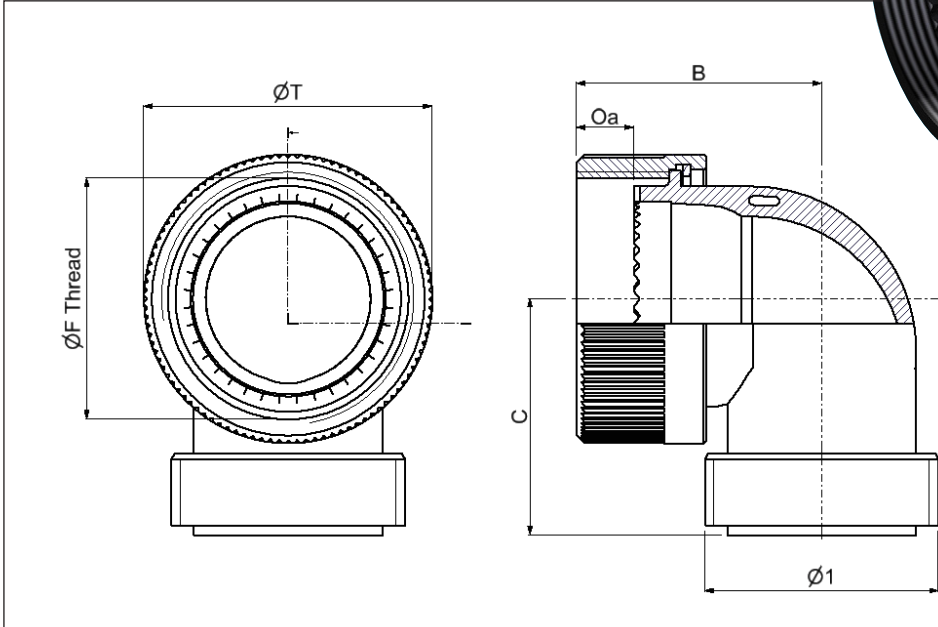

Shell Size	ØF Thread Class 2B	Ø1 Original Thread Class 2B	B Max	C Max	ØT Max	Oa Min Overlap Accessory
18	1" x 20 UNEF	1" x 20 UNEF	31.10	35.00	31.00	7.00
20	1 1/8" x 18 UNEF	1 3/16" x 18 UNEF	33.00		35.00	
22	1 1/4" x 18 UNEF		33.10		38.00	
24	1 3/8" x 18 UNEF	1 7/16" x 18 UNEF	37.90	40.00	41.00	
28	1 5/8" x 18 UNEF		37.10		48.00	
32	1 7/8" x 16 UN	1 3/4" x 18 UNS	43.10	45.00	54.00	
36	2 1/16" x 16 UNS	2" x 18 UNS	45.90	50.00	61.00	
40	2 3/16" x 16 UN	2 1/4" x 16 UN	49.00	54.60	67.00	

How to Order:
 ABBP ** ECHSA
 ** Shell Size

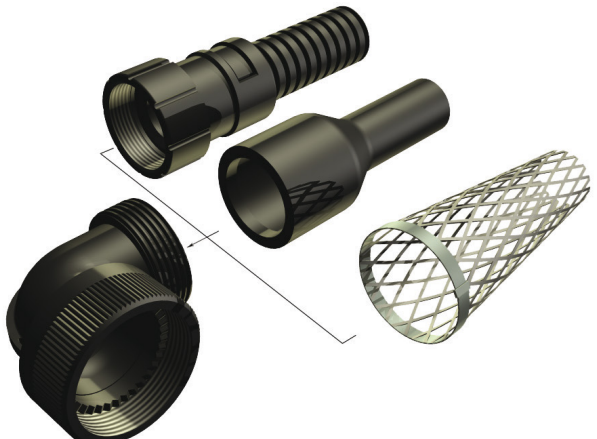

Thread measurement is imperial, all other measurements in mm.

ABCIRP

ABCIRP

shell heatshrink extender
SHE# (locking)

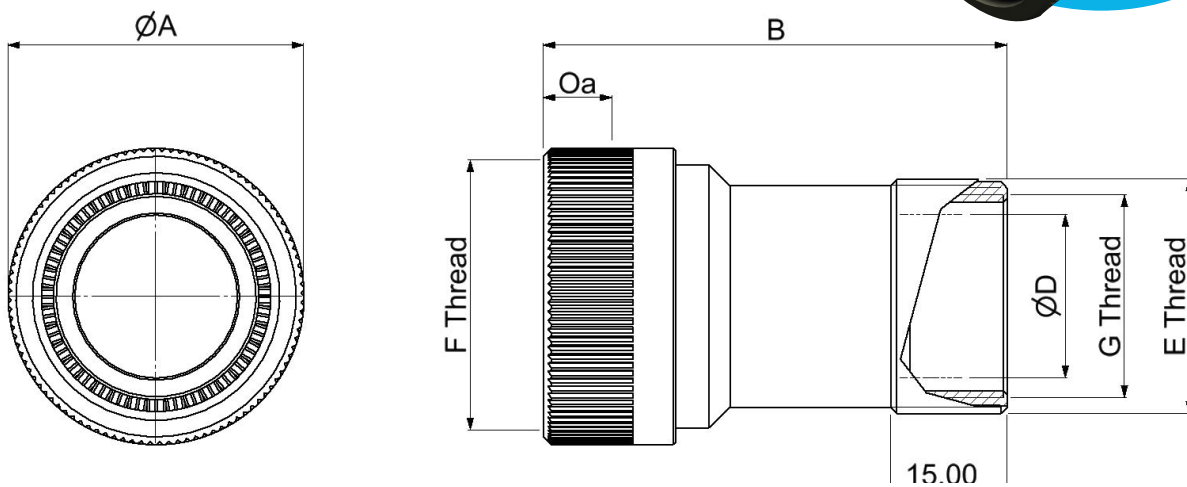

Shell Size	F Thread Class 2B	E Thread Class 2A	G Thread PG/METRIC	ØA Max	B	Overlap Oa Min
18	1'' x 20 UNEF	1'' x 20 UNEF	PG 13.5 M20x1.5	31.00	58.8	7.00
20	1 1/8'' x 18 UNEF	1 3/16'' x 18 UNEF	PG 16 M25x1.5	35.00		
22	1 1/4'' x 18 UNEF			38.00		
24	1 3/8'' x 18 UNEF	1 7/16'' x 18 UNEF	PG 21 M32x1.5	41.00	65.8	
28	1 5/8'' x 18 UNEF			48.00		
32	1 7/8'' x 16 UN	1 3/4'' x 18 UNS	PG 29 M40x1.5	54.00		
36	1 1/2'' x 16 UN	2'' x 18 UNS		61.00		
40	2 1/4'' x 16 UN	2 1/4'' x 16 UN	PG 36 M50x1.5	67.00		

How to Order:

ABBP ** SHE #

** Shell Size

M = Metric, P = PG

ABCIRP

step-up adapters
SUA# (locking)

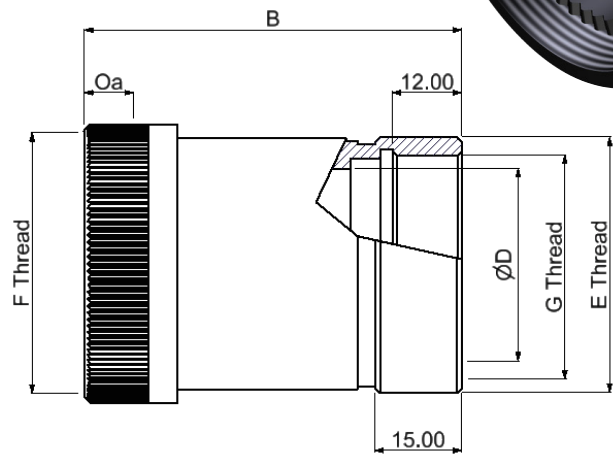
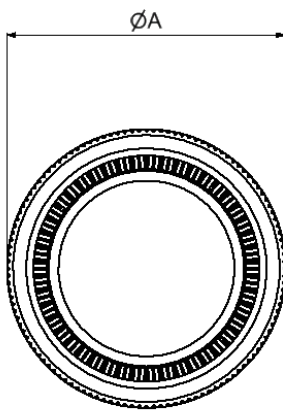
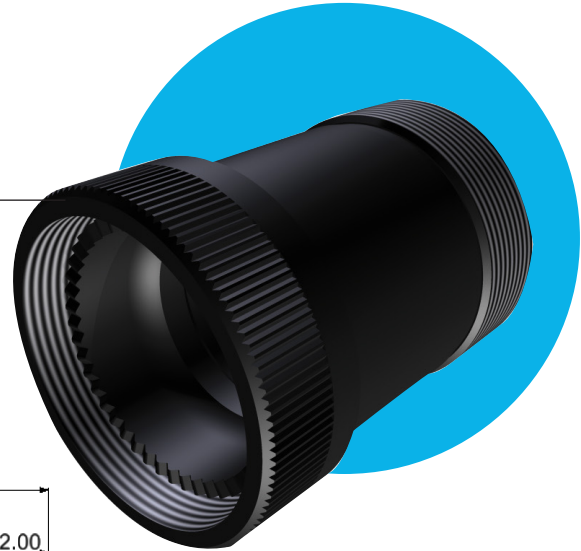

Shell Size	F Thread Class 2B	E Thread Class 2A	G Thread PG/METRIC	ØA Max	B	ØD Bore	Overlap Oa Min
18	1" x 20 UNEF	1 3/16" x 18 UNEF	PG 16 M25x1.5	31.00	58.8	16.7	7.00
20	1 1/8" x 18 UNEF	1 1/16" x 18 UNEF	PG 21 M32x1.5	35.00		19.8	
22	1 1/4" x 18 UNEF			38.00			
24	1 3/8" x 18 UNEF	1 3/4" x 18 UNS	PG 29 M40x1.5	41.00	65.8	25.4	
28	1 5/8" x 18 UNEF			48.00		27.0	
32	1 7/8" x 16 UN			54.00		32.5	
36	2 1/16" x 16 UNS	2" x 18 UNS	PG 36 M50x1.5	61.00	65.8	35.7	
40	2 5/16" x 16 UN	2 1/4" x 16 UN	PG 42 M50x1.5	67.00		45.0	

How to Order:

ABBP ** SUA #

** Shell Size

M = Metric, P = PG

ABCIRP

ABCIRP

step-down adapters
SDA (locking)

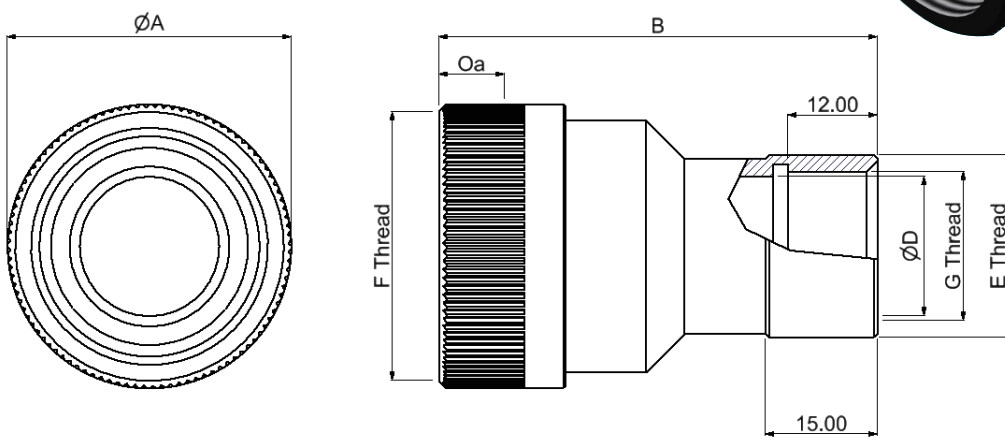

Shell Size	F Thread Class 2B	E Thread Class 2A	G Thread PG/METRIC	$\varnothing A$ Max	B	Overlap Oa Min
18	1'' x 20 UNEF	7/8'' x 18 UNEF	PG 11 M18x1.5	31.00	58.8	7.00
20	1 1/8'' x 18 UNEF	1'' x 20 UNEF	PG 13.5 M20x1.5	35.00		
22	1 1/4'' x 18 UNEF			38.00		
24	1 3/8'' x 18 UNEF	1 3/16'' x 18 UNEF	PG 16 M25x1.5	41.00	65.8	
28	1 5/8'' x 18 UNEF			48.00		
32	1 7/8'' x 16 UN	1 7/16'' x 18 UNEF	PG 21 M32x1.5	54.00		
36	2 1/16'' x 16 UNS	1 3/4'' x 18 UNEF	PG 29 M40x1.5	61.00		
40	2 3/16'' x 16 UN	1'' x 18 UNS		67.00		

How to Order:

ABBP ** SDA #

** Shell Size

M = Metric, P = PG

ABCIRP

cable gland adapters
 (fitting on SCHSA & ECHSA accessory with
 PG / METRIC thread)

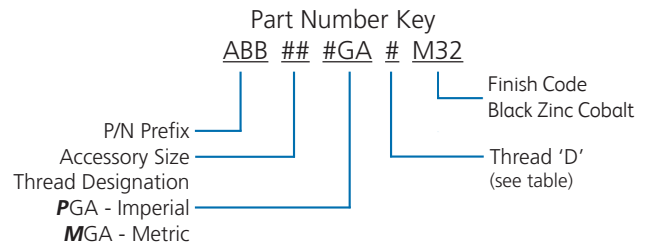
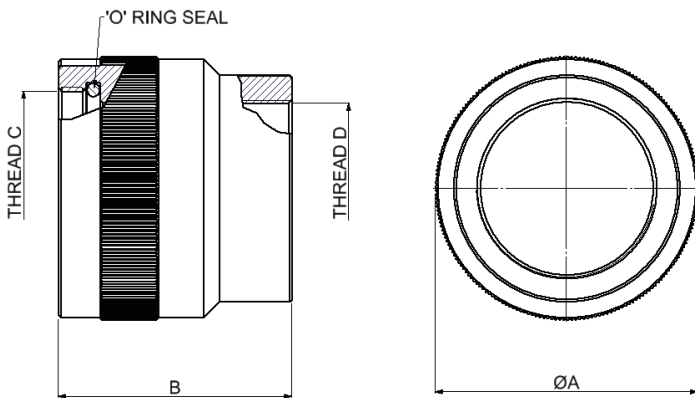

P/N Example to fit shell size 20 with a rear metric thread size M25

ABB 20 MGA DM32

Shell Size	Part Number	ØA	B	Thread C
18	ABB-18-#GA-#M32	34.00	40.00	1" x 20 UNEF
20-22	ABB-20-#GA-#M32	37.00	40.00	1 1/16" x 18 UNEF
24-28	ABB-24-#GA-#M32	43.00	40.00	1 1/8" x 18 UNEF
32	ABB-32-#GA-#M32	54.00	48.00	1 1/4" x 18 UNS
36	ABB-36-#GA-#M32	57.20	50.00	2" x 18 UNS
40	ABB-40-#GA-#M32	65.00		2 1/4" x 16 UN

Imperial (PGA)	Thread Size	Metric (MGA)	Thread Size
A	PG7	A	M12 x 1.5
B	PG9	B	M16 x 1.5
C	PG11	C	M20 x 1.5
D	PG13.5	D	M25 x 1.5
E	PG16	E	M32 x 1.5
F	PG21	F	M40 x 1.5
G	PG29	G	M50 x 1.5
H	PG36	H	M63 x 1.5
J	PG42		
K	PG48		

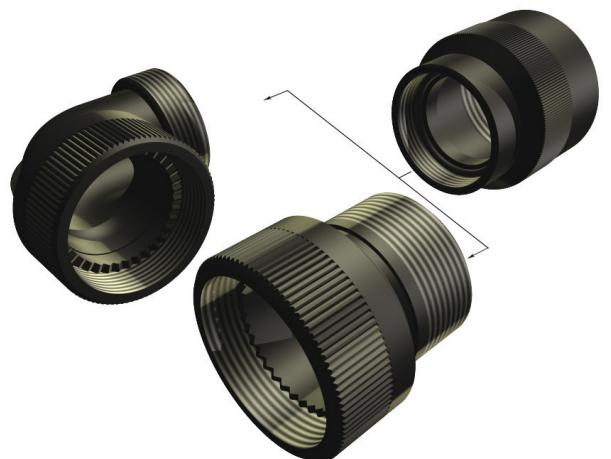

ABCIRP

ABCIRP

shell extender with screening
SPTAS (non locking)

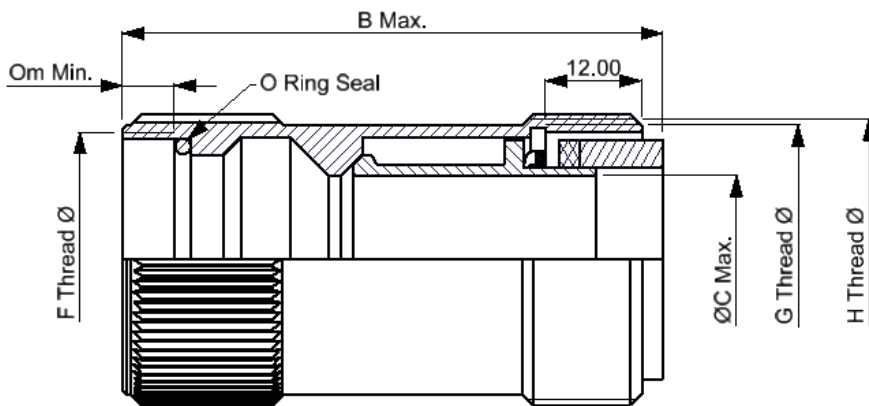
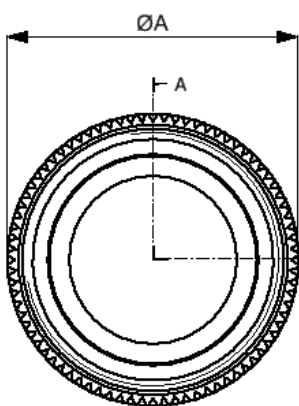
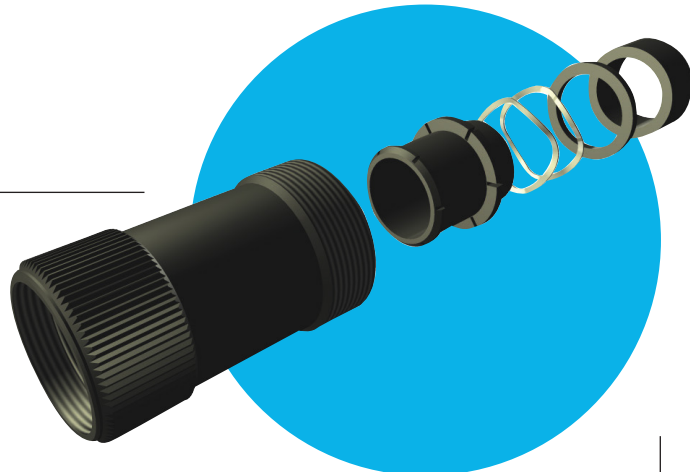

Shell Size	ØA	B Max	ØC Max	ØF Thread Class 2B	G Thread	ØH Thread Class 2A
18	29.50	68.00	11.30	1" x 20 UNEF	M25x1.5-6H	1 3/16" x 18 UNEF
20*	-	-	-	-	-	-
22	36.50	68.00	21.00	1 3/16" x 18 UNEF	M32x1.5-6H	1 1/16" x 18 UNEF
24*	-	-	-	-	-	-
28	43.00	70.00	27.50	1 1/16" x 18 UNEF	M40x1.5-6H	1 3/4" x 18 UN
32*	-	-	-	-	-	-
36*	-	-	-	-	-	-
40	64.00	70.00	39.00	2 1/4" x 16 UN	M50x1.5-6H	2 1/4" x 16 UN

How to Order:

ABBP ** SPTAS

** Shell Size

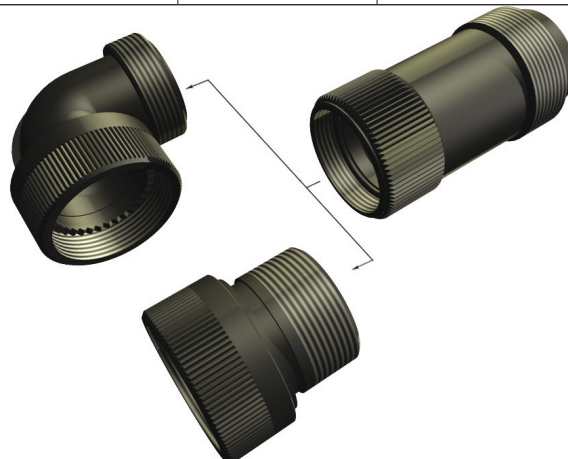

Note: * Please consult factory for these sizes

ABCIRP

adapters
CRA (2 piece adaptor to terminate cable screen braid to connector with conduit outer)

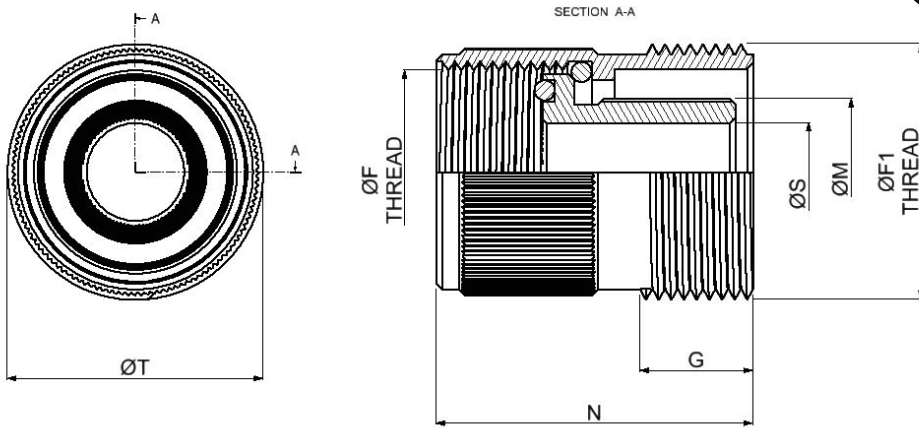
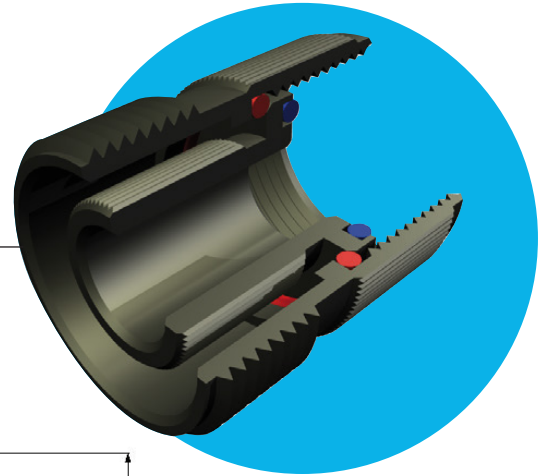

Shell Size	ØF Thread Class 2B	ØF1 Thread Class 2A	G Max	N Max	S Min	T Max	M Max
16S	7/8" x 20 UNEF	1" x 20 UNEF	10.00	27.60	9.74	25.50	13.10
18	1" x 20 UNEF	1 1/16" x 18 UNEF	11.00	30.60	12.90	29.10	16.26
20	1 3/16" x 18 UNEF	1 7/16" x 18 UNEF			18.23	35.45	21.51
22					1 7/16" x 18 UNEF	1 3/4" x 18 UNS	25.93
24	1 3/4" x 18 UNS	2" x 18 UNS					49.55
28			2" x 18 UNS	2 1/4" x 16 UN	13.00	32.00	35.19
32	32.33	63.10			35.60		
36	2" x 18 UNS	2" x 18 UNS	13.00		32.00	55.90	35.19
40	2 1/4" x 16 UN	2 1/4" x 16 UN			32.33	63.10	35.60

How to Order:
 ABBP ** SPTAS #
 ** Shell Size
 # M = Metric, P = PG

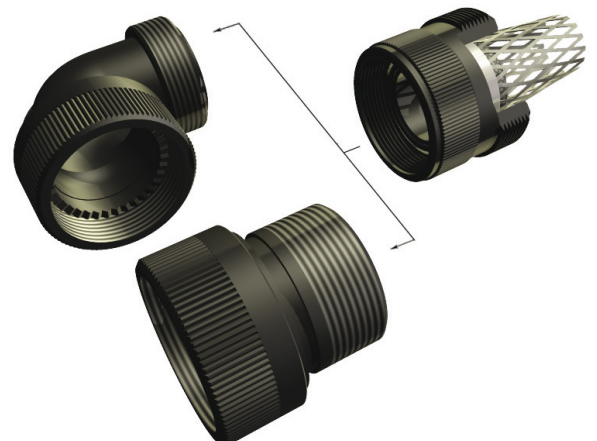

Note: with style SCHSA or ECHSA adaptors.
 This accessory can only be used in conjunction

ABCIRP

ABCIRP

waterproof clamp for jacketed cable
CMSP3057C

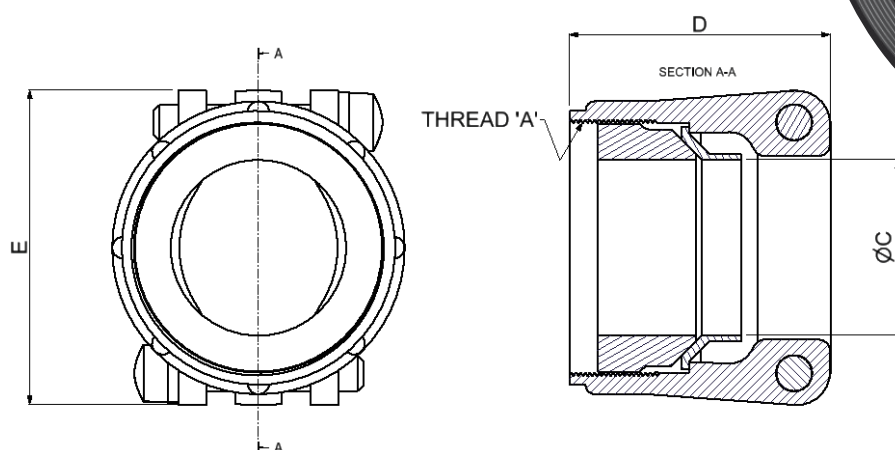

Shell Size	Part Number CMSP3057C**M32	ØA Thread Class 2A	ØC		D Max	E Max	
			Min	Max			
16 / 16S	16 / 16S	3/8" x 20 UNEF	7.92	13.48	34.93	30.18	
18	18	1" x 20 UNEF	9.53	15.87	36.50	33.32	
20	20	1 1/16" x 18 UNEF	12.70	19.00		39.21	
22	22		1 1/16" x 18 UNEF	15.09	23.80	39.67	44.45
24	24	1 3/4" x 18 UNS		23.83	31.75	46.02	57.15
28	28			2" x 18 UNS	24.61	35.00	52.37
32	32	2 1/4" x 16 UN	30.18		41.25	66.68	

ABCIRP

cable clamp
CMSP3057A

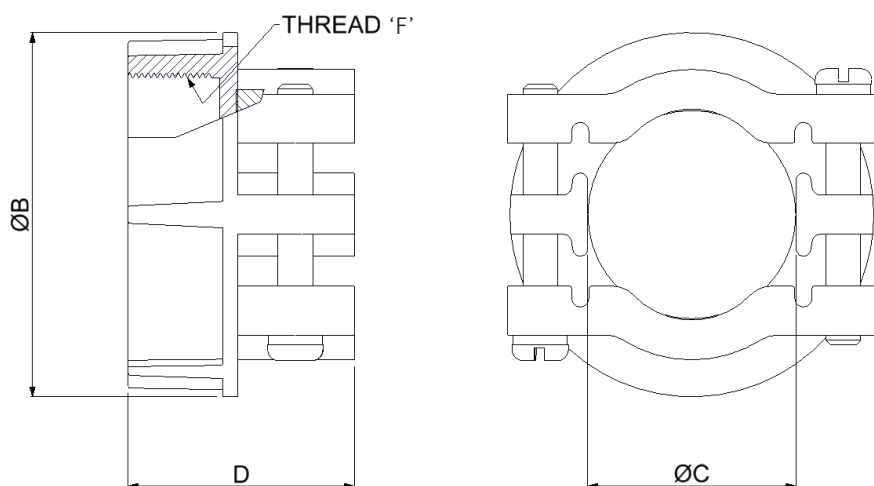
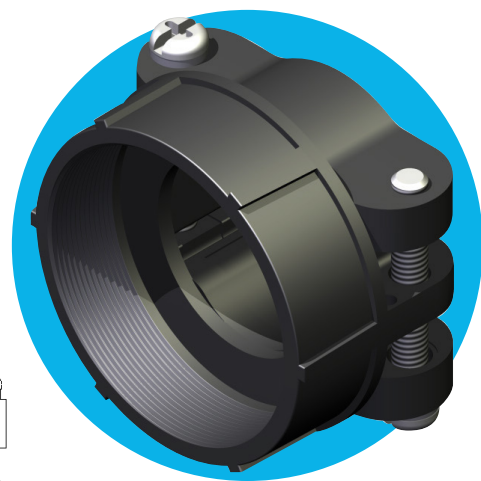

Shell Size	Part Number CMSP3057A**M32	ØF Thread Class 2A	B Max	C Max	D Max
16 / 16S	16 / 16S	$\frac{7}{8}$ " x 20 UNEF	28.58	14.30	24.61
18	18	1" x 20 UNEF	30.96	15.88	
20	20	$1\frac{3}{16}$ " x 18 UNEF	35.71	19.05	
22	22				
24	24	$1\frac{7}{16}$ " x 18 UNEF	42.85	23.83	26.97
28	28	$1\frac{3}{4}$ " x 18 UNS	52.37	31.75	28.58
32	32				
36	36	2" x 18 UNS	57.15	34.93	30.15
40	40	$2\frac{1}{4}$ " x 16 UN	64.29	41.28	43.66

ABCIRP

ABCIRP

telescopic bushing
SBMSH554

(use with CMSP3057A clamp)

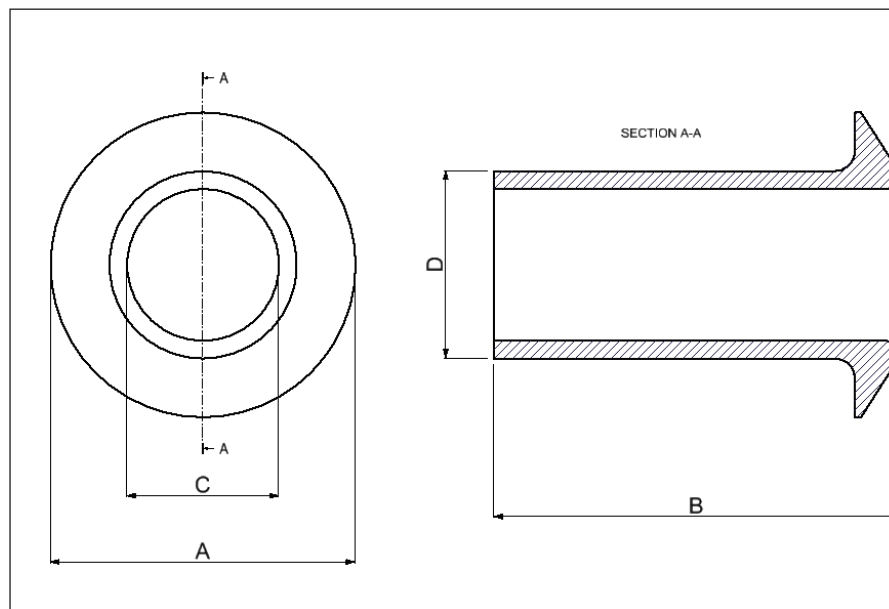
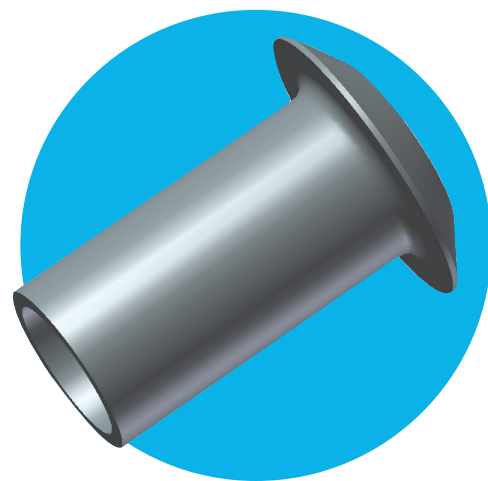

Shell Size	Part Number SBMSH554**	ØA	B	ØC	ØD
16 / 16S	3	19.05	63.50	11.10	13.97
18	4	22.23	60.33	14.27	15.57
20	5	25.40	57.15	15.88	18.75
22	6	28.58			
24	7	31.75	53.98	19.05	23.50
28	8	38.23			
32	9	44.45	50.80	23.80	31.45
36	10	47.88	47.63	31.75	34.62
40	11	52.90	44.40	34.92	40.99

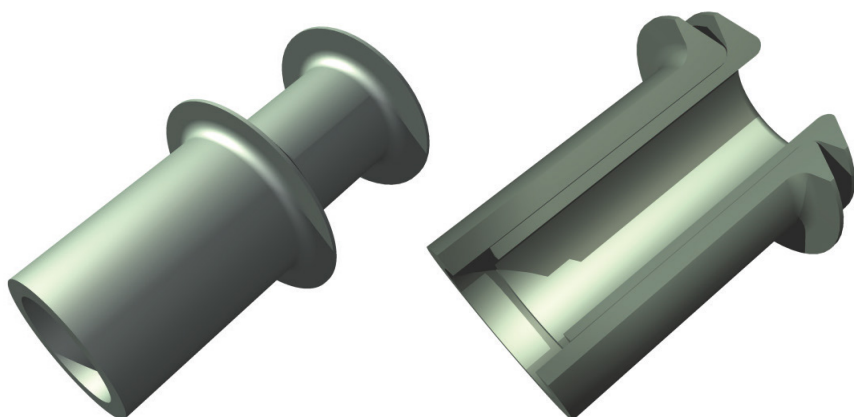

Note: Through bore reduction possible by telescoping bushings

ABCIRP

panel gasket, non-conductive / conductive
front & rear mounted connectors
RPG/S & FPG/S

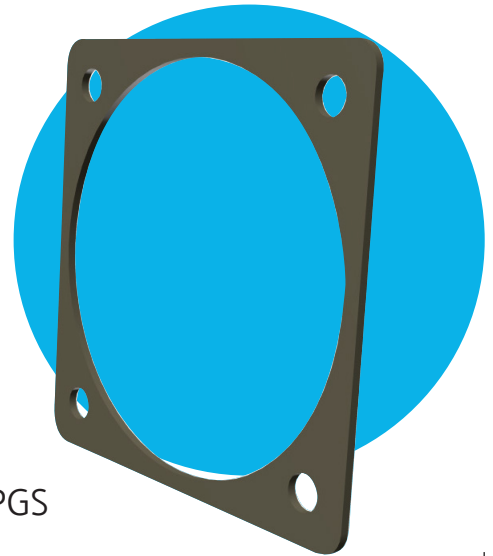

SB**RPG / RPGS

SB**FPG / FPGS

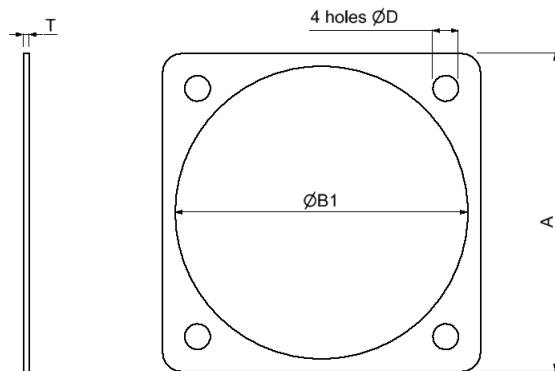
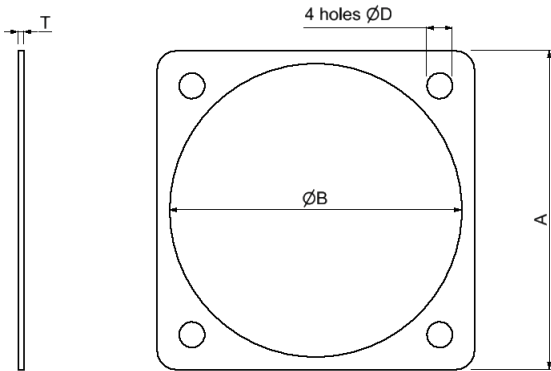

Shell Size	A Min	ØB Nominal	ØB1 Nominal	Ød Min	T Nominal
18	34.90	25.40	30.90	3.43	1.00
20	38.10	28.60	34.30		
22	41.30	31.70	37.50		
24	44.50	34.90	41.00	4.12	
28	50.80	41.30	46.80		
32	57.20	47.60	53.50	4.78	
36	63.50	52.60	59.70		
40	69.90	61.90	65.50	5.10	

How to Order:

Part Numbers:

	Non-conductive	Conductive
Front Mounted	SB ** RPG	SB ** RPGS
Rear Mounted	SB ** FPG	SB ** FPGS

** Shell Size

Note: Conductive gaskets have a conductivity of 5m Ohms, temp range of -50 to +200°C.

ABCIRP

ABCIRP

connector fixing nut plates

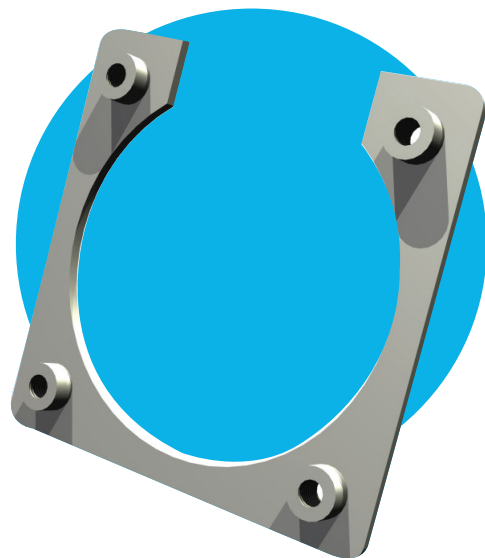

ABB**NP

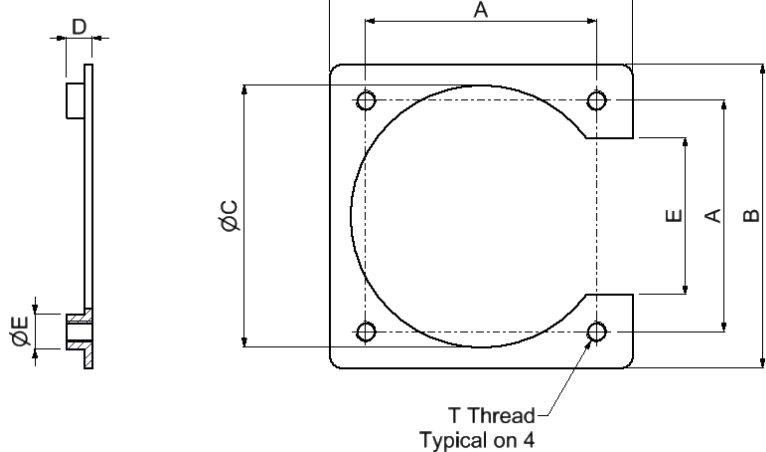

Shell Size	A	B Max	CØ Max	D	E Max	FØ Max	T Thread (Metric)	Part Number ABB**NP (Metric)	T Thread (Imperial)	Part Number ABB**NPA (Imperial)	
18	26.97	34.62	30.48	2.69/4.22	20.21	6.00	M3x0.5	18	4-40 UNC	18	
20	29.36	38.48	33.53		22.47			7.50		20	20
22	31.75	40.84	36.65		23.54					22	22
24	34.93	44.83	40.00		25.90	24		24			
28	39.67	51.18	46.61		29.08	28		28			
32	44.45	59.10	52.75	3.50/5.00	30.68	8.00	M4x0.7	8-32 UNC	32		
36	49.23	63.86	59.10		35.43		36		36		
40	55.58	74.68	68.33		38.60		40		40		

grommet filler plug



Damage to grommet



Grommet filler plug

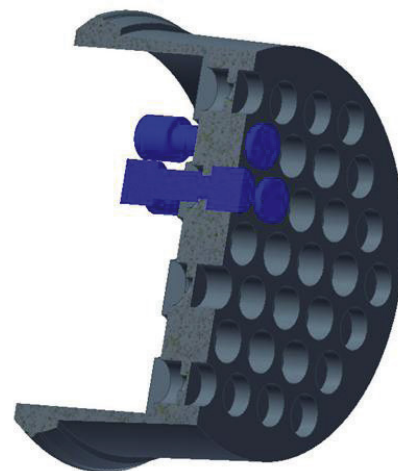

Sealed using filler plugs

ABB16KFP -
 ABB12KFPF80 -
 ABB8KFPF80 -

To be used if grommet is pierced incorrectly

ABCIRP

receptacle mounting detail

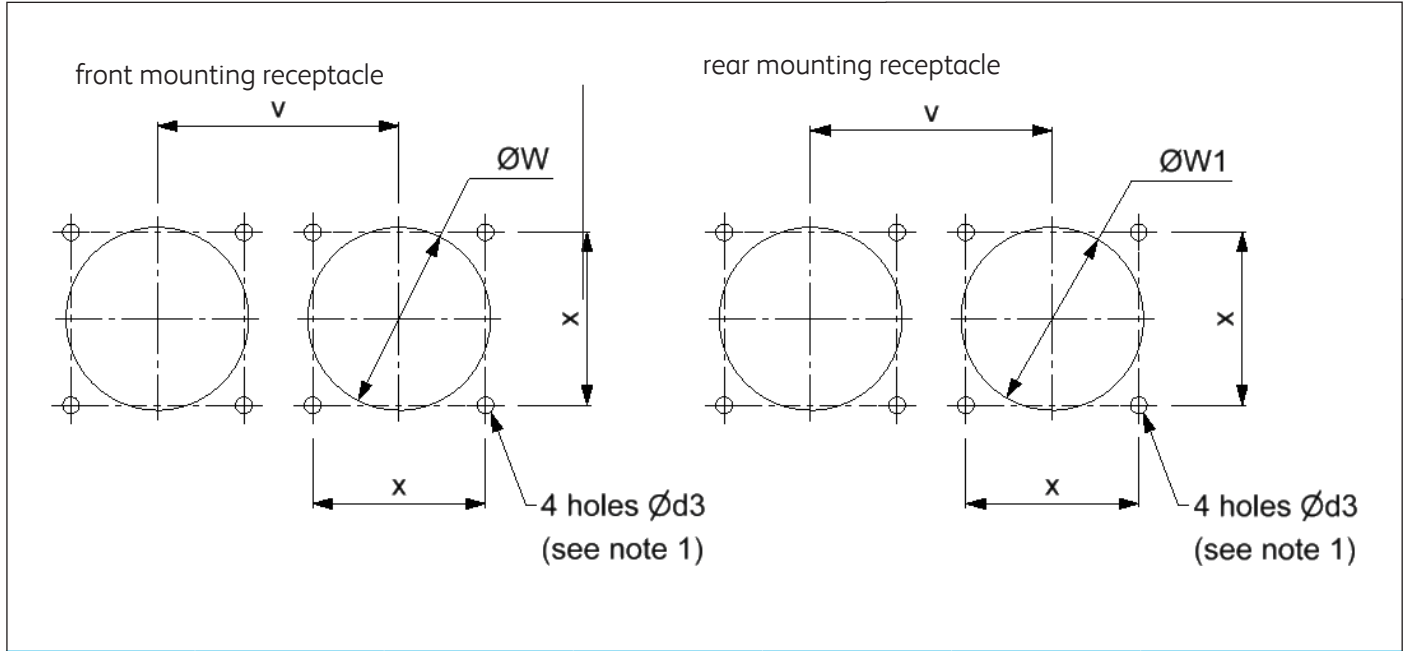

Shell Size	Ød3	Ød4	V	ØW	ØW1	X
18	3.40	4.50	38.30	26.00	31.18	27.00
20			41.70	30.00	34.58	29.40
22			45.20	33.00	37.78	31.80
24	3.90		48.70	36.00	41.28	34.90
28			55.50	42.00	47.08	39.70
32	4.50	5.50	62.40	48.50	53.78	44.50
36			69.00	55.00	59.98	49.20
40			75.00	59.10	66.40	55.50

Shell Size	Hole centres	ØJ	K	H
18	48.85	35.23	33.58	48.85
20	52.05	38.43	36.68	52.05
22	55.45	41.56	39.88	55.45
24	58.45	44.78	43.18	58.45
28	65.25	51.13	49.37	65.25
32	71.55	57.48	55.78	71.55
36	77.95	63.83	62.18	77.95
40	85.25	70.18	68.38	85.25

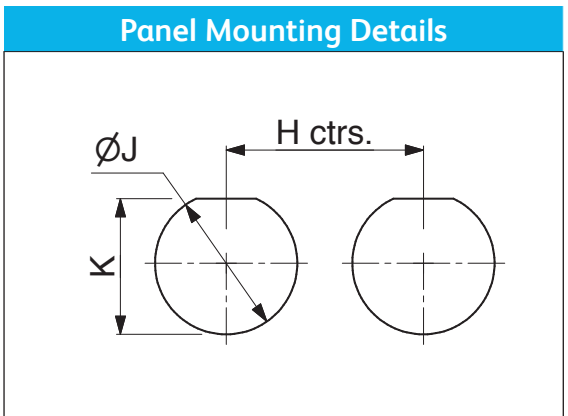

Note: When fixed connectors are used with plugs having rubber coupling nuts, please consult factory for panel cut-out dimensions.

When fixed connectors are used with threaded mounting holes, refer to hole sizes in column Ød4.

ABCIRP

ABCIRP

metal protective caps

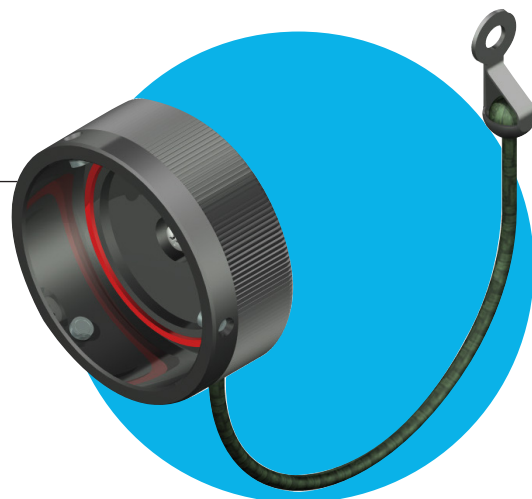

ABBE**XPCA M32 (with nylon cord)

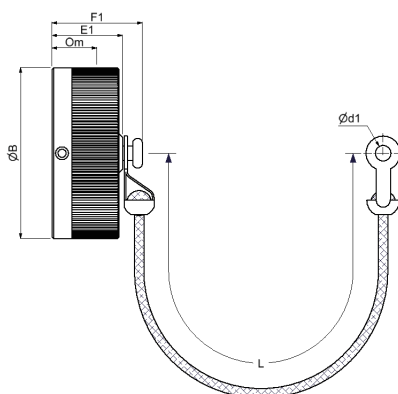

ABBE**XPCA M32 (with sash chain)

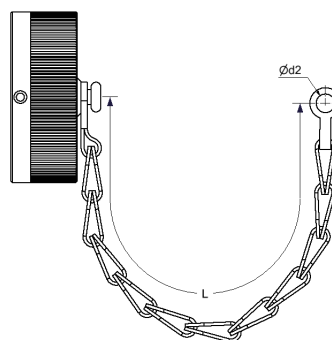

ABB**EPCA M32 (with nylon cord)

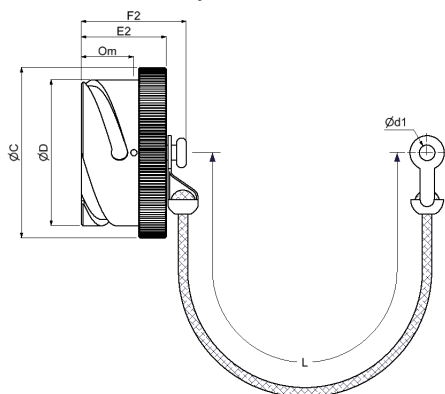

ABB**EPCA M32 (with sash chain)

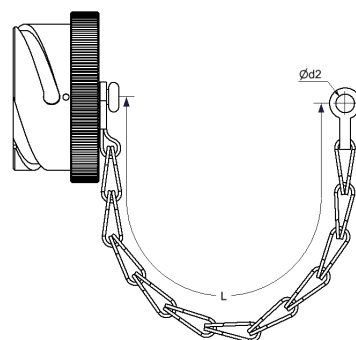

Shell Size	B Max	C Max	D Max	E1 Max	E2 Max	F1 Max	F2 Max	L (approx)	d1 Min	d2 +0.5, -0 +0.02, -0	Om Min Overlap Mated
18	36.50	38.70	30.80	24.00	27.30	29.80	33.90	150.0	4.85	4.30	15.85
20	39.90	42.10	34.20								
22	43.10	45.30	37.40								
24	46.60	48.80	40.90								
28	53.40	54.60	46.70	27.00						15.75	
32	60.10	61.30	53.40								
36	66.30	67.50	59.60								
40	72.10	73.40	65.50								

ABCIRP

RFI braid sock, band strap & knit mesh braid

RFI Braid Sock

AB Connectors Part Number	Diameter	Length	Max Shell Size
ABBMBS020010	ø 20 mm	100 mm	22
ABBMBS025015	ø 25 mm	150 mm	22
ABBMBS035015	ø 35 mm	150 mm	32
ABBMBS050015	ø 50 mm	150 mm	36 & 40

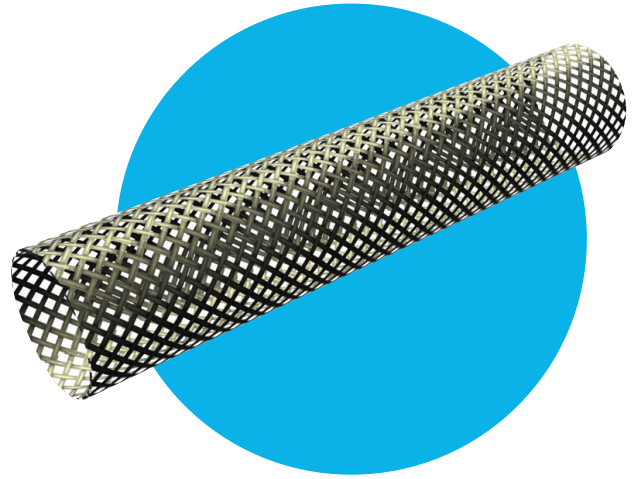

Bandit Strap

AB Connectors Part Number	Length	Width	Max Shell Size
ABB600052	520 mm	6.1 mm	32
ABB600090	900 mm	6.1 mm	36 & 40
ABB608109	362 mm	4 mm	22
ABB600057	207 mm	3 mm	22

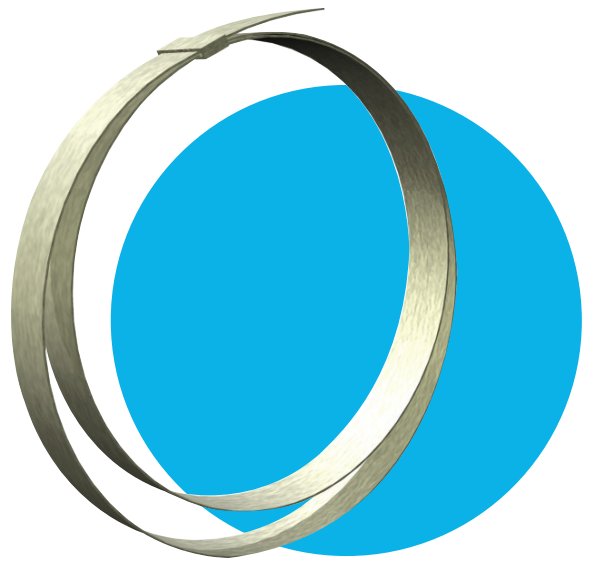

Bandit Tools

AB Connectors Part Number	Tool Description
ABB600058	Standard Bandit Tool
ABB600061	Micro Bandit Tool (3mm Band Straps)
ABB601200	Calibration Kit

Knitmesh Braid

AB Connectors Part Number	Length	Width
ABBMKM1050	500 mm	25 mm

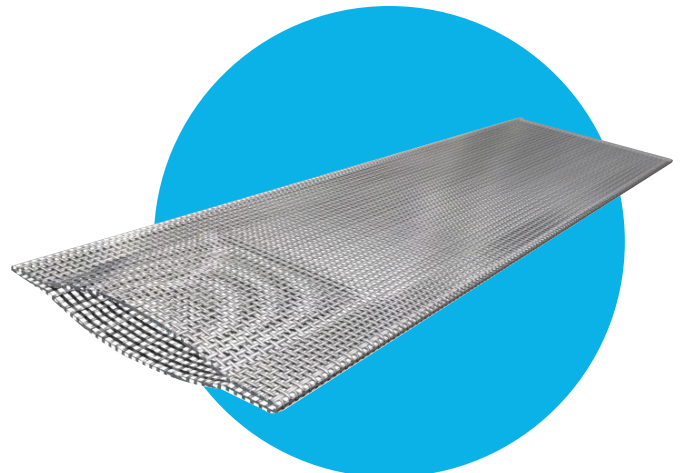

ABCIRP

ABCIRP

crimp contacts - tooling

Pneumatic Crimp Tool

Contact sizes 12 and 16



AB Part No: ABBFT8
Supplier DMC part no: FT8

Pneumatic Crimp Tool

Contact sizes 12 and 16



AB Part No: ABWA27F
Supplier DMC part no: WA27F

Turret Locator

Contact sizes 12 and 16
(to locate contacts within a crimp tool)

AB Part No: ABBTH592
Supplier DMC part no: TH592

Hand Crimp Tool

Contact size 100



AB Part No: ABBD51
Supplier Dubuis part no: D51

Electric Crimp Tool

Contact size 100



AB Part No: ABBPL0550A1130

Die Sets

crimping contact size 8 & 100



AB Part No: ABMRP0925

Insertion Tool

Contact sizes 12 and 16
(to insert contact into plastic insert)

AB Part No: P80 12 ITL (size 12)
AB Part No: P80 16 ITL (size 16)
Supplier Astro Tools part no: AT 1110

Extraction Tool

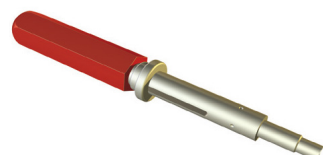
Contact size 8
(to extract from plastic insert)

AB Part No. P80 8 ETA

Extraction Tool

Contact sizes 12 & 16
(to extract from plastic insert)

**AB part no. P80 12 ETA (size 12) /
P80 16 ETA (size 16)**

Grommet Extraction Tool

Contact sizes 12 & 16
(to extract contact through grommet)

**AB part no. P80 12 GET (size 12) /
P80 16 GET (size 16)**

ABCIRP

crimp contacts - supplementary tooling

Contact Retention Tester

(applies a load to test contact is seated correctly)



AB Part No: 6M3800644

Supplier DMC part no: HT250-3

Contact Socket Retention Test Probe

Contact sizes 12 & 16



AB Part No: 6M3800731 (size 12) / 6M3800646 (size 16)

Supplier DMC part no: 67-012-01 / 67-016-01

Contact Pin Retention Test Probe

Contact sizes 12 & 16

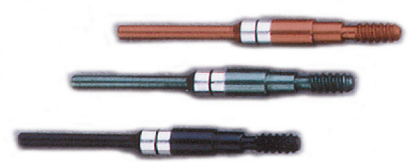

AB Part No: 6M3800730 (size 12) / 6M3800645 (size 16)

Supplier DMC part no: 68-012-01 / 68-016-01

Grommet Assembly Aid

shell size 18-24 / 28-40

(to tuck grommet shoulder into connector)

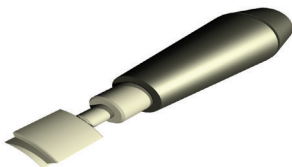

AB Part No. P8018GAT (size 18 - 24)

AB Part No. P8028GAT (size 28 - 40)

ABCIRP

ABCIRP

safety information

This information is to be used in conjunction with the Product Catalogue and Product Specification. Products may be safely used in the applications for which they have been designed and within the specified ratings and environments. If products are exposed to conditions outside the performance ratings or specified environments they may constitute a hazard. In particular it should be noted that:-

1. Material Content of Products.

Circular Connectors generally use metalwork parts made of copper, copper alloy, aluminium alloy, aluminium-bronze, phosphor-bronze or steel, which, dependant on the particular application, may be passivated and protected with cadmium or zinc plate – in conjunction with chromated or anodised surface finishes. The insulating materials can be either natural or synthetic rubber, together with plastic or glass filled plastic moulded parts. Contact materials vary with product type but are usually made of copper, copper alloy, nickel, phosphor-bronze, alumel, chromel or steel.

2. Electric Shock, Burns and Fire.

Hazard can occur if the product is used outside the specified parameters or if the product is damaged, wrongly wired or poorly assembled, or poorly integrated into larger equipment, or contaminated with conductive fluids. Live circuit terminations must be protected and live circuits never broken by demating products.

Hotspots may be created when resistance is increased due to damage or incorrect integration particularly soldering, crimping or loose terminations. Overheating can cause breakdown of insulation, electric shot, burns or, ultimately, fire. In the event of fire noxious and/or toxic fumes may be released and, in these circumstances, any fire involving the product should be dealt with by personnel properly equipped.

Connector products with exposed terminators or contacts should not be used on the current supply side of a circuit with exposed contacts on an unmated product. Before making a circuit live, the product and wiring should be checked to ensure that there is no damage and no electrically conducting debris present. Circuit resistance checks should also be conducted before making the circuit live. Always ensure that the correct tools, (specified by AB Connectors Ltd.) are employed for crimping and assembly and that connectors are assembled and wired by properly trained personnel.

3. Disposal of Products.

Products should not be burnt.

4. Use Transport and Storage of Products.

Care must be exercised to avoid damage to any part of the products during transporting, storage or use. The products, as manufactured, are free of sharp edges. Abnormal transit or storage conditions and abuse during installation can give rise to damage. Products should not be used in a damaged condition. Improper storage (particularly of damaged products) can give rise to additional hazards particularly corrosion. Your attention is specifically drawn to the need of proper storage of products containing cadmium and you are advised to see the Guidance Note from the Health and Safety Executive on Cadmium - Health and Safety Precautions.

Safety Rules

1. Ensure all conductor wires are capable of withstanding the electrical and environmental conditions of the application.
2. Always use the correct assembly tools for cables, contacts and connectors.
3. Make circuit resistance checks before making a circuit live.
4. Always protect live circuits and never demate a live connector.
5. Never use a damaged connector.
6. Never burn discarded connectors or cable.
7. IF IN DOUBT, ASK.

N. B. Additional information on the products and the materials used in them may be obtained from the Sales Department of AB Connectors Ltd.

Shelf life for rubber components

AB Connectors incorporate a number of rubber components within their connectors. Most rubbers change in physical properties during storage e.g. excessive hardening, softening, cracking or other surface degradation. These changes may be the result of particular factors or a combination of factors such as light, heat, humidity, oils or solvents.

With a few simple precautions the shelf life may be considerably lengthened.

The storage temperature should be between +5 and +25 degrees C. Direct contact with sources of heat such as boilers, radiators and direct sunlight should be avoided. It is advisable to cover any windows of storage rooms with a red or orange coating or screen. The relative humidity in the storeroom should be below 70%. Very moist or very dry conditions should be avoided. Condensation should not occur.

If the above recommendations are adhered to, then AB Connectors would warrant a shelf life of four years for its products.

N. B. The company reserves the right and may change or vary specification without prior written notice.

Global Presence

The world's demand for electronics is increasing as new technologies, with a higher dependence on complex components, are being adopted by a broader customer base. This growth provides TT electronics an assured future as we focus on efforts to deliver excellence in customer service and quality products to these markets. From our strong UK base, the company has achieved truly global reach. We have established technical and manufacturing facilities in strategic countries maintaining the successful formula of close liaison with our customers in all major overseas markets.

In addition, through strategic relationships with Original Equipment Manufacturers around the world, we are now in the enviable position where we gain double benefit - from growth in their markets and from the increase in the electronic content of end products.

Information on TT electronics companies can be found by contacting:-

Head Office:

TT Electronics plc
Fourth Floor, St Andrews House
West Street
Woking
Surrey
GU21 6EB
UK

Tel: +44 (0) 1932 825300

Fax: +44 (0) 1932 836450

Email: info@ttelelectronics.com

Web: www.ttelelectronics.com

AB Connectors



AB Connectors Limited
Abercynon,
Mountain Ash
Rhondda Cynon Taff
CF45 4SF, UK.
Tel: +44(0)1443 740331
Fax: +44(0)1443 741676
Internet:
<http://www.ttelectronics.com/ab-connectors>
connectors@ttelectronics.com

General Note TT Electronics reserves the right to make changes in product specification without notice or liability. All information is subject to TT Electronics' own data and is considered accurate at time of going to print.

Mouser Electronics

Authorized Distributor

Click to View Pricing, Inventory, Delivery & Lifecycle Information:

[TT Electronics:](#)

[ABCIRPSE06SCHSA2214GSLSV0N](#) [ABCIRPSE06SCHSA2214GPLPFSV0N](#) [ABCIRP12KPKP3](#) [ABCIRP2015GPL](#)
[ABCIRPSE06T2214SV0N](#) [ABCIRP20XR](#) [ABCIRP2015PFS](#) [ABCIRP2015S](#) [ABCIRP03SCHSA28](#)
[ABCIRPSE06T2821SV0N](#) [ABCIRP2214GPS](#) [ABCIRP16KLKP3](#) [ABCIRP16KPKP3](#) [ABCIRP1819S](#) [ABCIRP18XR](#)
[ABCIRP22XR](#) [ABCIRPSE06T40A35SV0N](#) [ABCIRP1620KLKP3](#) [ABCIRP22IC](#) [ABCIRP03T1819PFSV0N](#)
[ABCIRP2821GPL](#) [ABCIRP2821PFS](#) [ABCIRP2015GSS](#) [ABCIRP1618KLKP3](#) [ABCIRP1618KPKP3](#)
[ABCIRP36A22GPL](#) [ABCIRP36A22GSL](#) [ABCIRPSE06T36A22SV0N](#) [ABCIRPSE06T40A60SV0X](#) [ABCIRP40M1GS](#)
[ABCIRPSE06T2214PFSV0N](#) [ABCIRP28IC](#) [ABCIRP1620KPKP3](#) [ABCIRP03T2015PV0N](#) [ABCIRP2015GSL](#)
[ABCIRP1819PFS](#) [ABCIRP1819GPS](#) [ABCIRP2214GSS](#) [ABCIRP1622KLKP3](#) [ABCIRP18M3GP](#) [ABCIRP18M3GS](#)