

AB05/6

Connectors

Mil-C-26482 Series 1 Style



Company Profile

TT Electronics' brand AB Connectors specialises in the design, test and manufacture of high performance electronic connectors and interconnect solutions, supplying a range of global customers in aerospace, defence, rail and industrial markets.

Our broad product portfolio which includes miniature connectors, high power connectors, soldier systems, harness assemblies and box systems typically serve within key applications such as signalling, communication and power distribution.



Operating from the principle site in Abercynon, South Wales, our research and development teams have an excellent track record for developing innovative industry solutions and our engineers have extensive experience in designing a range of product configurations to meet customer specific requirements for the most demanding environments.

From plant layout to production line set-up and quick changeover processes, we offer the ideal service, with a flexible manufacturing environment and accredited facilities.

Quality systems and approvals include ISO9001 along with various product and market sector approvals including the military Mil-std 790 and mass transit IRIS certifications and environmental approval to ISO14001. As a result of these qualifications AB Connectors has been awarded several major customer approvals and accreditations.

AB Connectors total commitment to providing customers with high levels of service, cost effectiveness, quality and innovative solutions in interconnection products make it the ideal first choice supply partner.



Contents

- 2 - 36 AB05 - Miniature Bayonet Coupling Connectors
- 37 - 42 AB05 - 10-76 Miniature Bayonet Coupling Connectors
- 43 - 61 AB06 - Audio Miniature Bayonet Lock Connectors



AB05

Miniature Bayonet Coupling Connectors



The AB05 Series Miniature Bayonet Coupling connectors fully conform to the stringent requirements of British Standard 9522 F0017. This specification supercedes Defence Standard 59-35 (Part 1), which was itself based on the American Military Specification Mil-C-26482 Series 1 (solder).

Initially developed for aircraft applications, miniature bayonet coupling connectors are now extensively used in fighting vehicles, military communications, professional audio and general industrial markets where high reliability, miniaturisation and cost effectiveness are of prime importance.

AB05 series connectors are interchangeable and intermateable with similar connectors of British, European or American origin.

Positive coupling is indicated by an audible click and by visual alignment of the three bayonet pins with locating windows in the coupling nut.

Aluminium alloy shells and a choice of surface finishes, offer a high resistance to corrosion. A choice of colour is available for occasions where the connector has to match the finish of the equipment.

Insulators are polychloroprene with an operating temperature range of between -55°C to 125°C . Contact arrangements with from 2 to 61 ways feature size 16 AWG (13 amps) or size 20 AWG (7.5 amps) solder bucket, crimp or P.C.B contacts.

Sealing against water and dust ingress is achieved between mating connectors by using a square section gasket between shells, by a peripheral seal on the insulators and by individual wire seal grommets.

In response to modern environmental considerations, AB05 connectors can be specified with alternative cadmium free surface finishes.



AB05

Miniature Bayonet Coupling Connectors

Contents	Page
AB05 Miniature Bayonet Coupling Connectors	2-36
Technical Information	4
Part No. Explanation	5
Arrangement Specifications	6
Contact Arrangements	7-8
Receptacles	
AB05 1000: cable connecting receptacle	9
AB05 2000: receptacle, square flange with accessory thread	10
AB05 2100: receptacle, square flange w/o accessory thread	11
AB05 3100: receptacle, jam nut w/o accessory thread	12
AB05 3200: receptacle, jam nut with accessory thread	13
Plugs	
AB05 6000: plug, knurled coupling nut	14
AB05 6100: plug, knurled coupling nut with grounding fingers	15
AB05 6200: plug, coarse ribbed coupling nut	16
AB05 6300: plug, coarse ribbed coupling nut with grounding fingers	17
Accessories	
Accessories Part No. Explanation	18
AB05 0027: strain relief clamp	19
AB05 0029: straight outlet for internally screened cables	20
AB05 0030: straight outlet for externally screened cables	21
AB05 0040: grommet nut	22
AB05 0050: general duty adaptor	23
AB05 0055: sealing gland	24
AB05 0062: sealing gland with integral cable clamp	25
AB05 0065 / AB05 0066: cover for square flange receptacle	26
AB05 0070: cover for plug	27
AB05 0075: screen and heat shrink adaptor	28
AB05 002*: screening heat shrink adaptor, sealing type	29
AB05 003*: screening heat shrink adaptor 90° outlet, sealing type	30
AB05 size240-0-00-AC: filler plug	31
AB05 size382-0-00-AC: panel gasket	31
AB05 size430-0-00-AC: cable grommet	32
AB05 2300: stowage receptacles	32
AB05 Printed Circuit Board Contacts	33
AB05 Crimp Contacts and Assembly Tools	34
Assembly Procedures for Cables used on AB05 0029 and 0030 Straight Outlets	35-36
AB05 10-76 Miniature Bayonet Coupling Connectors	37-42
AB06 Audio Miniature Bayonet Lock Connectors Range	43-61
Safety Information	62

ABO5

Technical information

Mechanical Features

Shell size:	8 to 24, measured in sixteenths of an inch
Coupling:	Three pin bayonet
Contact Termination:	Solder bucket, crimp (rubber retention), pin tails for P.C.B. applications and flexible printing wiring
Sealing:	Barrier, or barrier and panel seal. Dynamic peripheral seal between mating shells.

Materials

Shell:	Aluminium alloy
Insulator:	Polychloroprene
Grommet:	Polychloroprene
Contacts:	Brass
Accessories Hardware:	Aluminium alloy

Plating Finishes

Shell:	Conductive, olive drab over cadmium plate (alternatives available on request)
Contacts:	Gold over nickel
Accessory Hardware:	Conductive, olive drab over cadmium plate (alternatives available on request)

Technical Data

Temperature Range:	-55°C to +125°C
Voltage at Sea Level:	a) Working Voltage - d.c. or a.c. peak: Size 20 Contacts: 700V (Voltage rating 1) Size 16 Contacts: 1200V (Voltage rating 2) b) Proof Voltage - d.c. or a.c. peak: Size 20 Contacts: 2100V (Voltage rating 1) Size 16 Contacts: 3000V (Voltage rating 2) The establishment of electrical safety factors when the connector is used at other than the working voltage is the responsibility of the user.
Environmental Ratings:	a) Shock severity: 981 m/s ² (100g _n) for 6 milliseconds. b) Vibration: 10Hz-5000 Hz, 0.75 mm/10g _n duration; 30 hours (including 1 hour at -55°C and 3 hours at 125°C). c) Acceleration: 490 m/s ² (50g _n) d) Humidity severity: 44 millibars e) Bump severity: 390 m/s ² (40g _n), 4000 ± 10 bumps f) Mechanical endurance: 500 matings g) High temperature: Long term: 1000 hours at 85°C Short term: 250 hours at 125°C

Orientation:

To prevent mismatching or cross-plugging, shell to shell, key to keyway orientations are offered in normal (N) or any of four alternatives (B,C,E or F). Insert orientation, permissible in Pattern 105 connectors to enable replacement of existing MIL-C-26482 types, is available by special request.

AB05

Part number explanation

To illustrate the ordering procedure, part number AB05100010**PF00 is shown in the table below:

Product Range:	AB05	10	00	10	**	P	F	00
Shell Style:	<ul style="list-style-type: none"> 10 : Cable connecting receptacle 20 : Square flange receptacle with accessory thread 21 : Square flange receptacle without accessory thread 31 : Jam nut receptacle without accessory thread 32 : Jam nut receptacle with external accessory thread 60 : Plug with knurled coupling nut 61 : Plug with knurled coupling nut & spring grounding fingers 62 : Plug with coarse ribbed coupling nut 63 : Plug with coarse ribbed coupling nut & spring grounding fingers 							
Accessory Class:	<ul style="list-style-type: none"> 00 : No accessory 27 : Strain relief clamp 29 : Straight outlet internally screened 30 : Straight outlet externally screened 40 : Grommet nut 50 : General duty adaptor (No grommet necessary) 55 : Sealing gland (No grommet necessary) 62 : Sealing gland with integral cable clamp 75 : Screen and heat shrink adaptor 2* : Screening heat shrink adaptor, sealing type (* Indicates Entry Size, see page 29) 3* : Screening heat sink adaptor 90° outlet, sealing type 							
Shell size:	08, 10, 12, 14, 16, 18, 20, 22, 24 (Increase in sixteenths of an inch)							
Contact layout:	** See pages 7-8							
Contact type:	<ul style="list-style-type: none"> P : Pin S : Socket 							
Orientation:	N, B, C, E & F (Insert orientation available only for replacement of MIL-C-26482 types. Please consult factory)							
Modification:	<ul style="list-style-type: none"> 00 : Solder contacts 01 : Crimp contacts. (Size 20, small bore, Ø 0.84) (Bore Ø 1.75, Size 16 only) 02 : Crimp contacts. (Size 20, large bore, Ø 1.24) (No Size 16 contact) 03 : P.C.B. contact 0.73 ± 0.025/2 mm. 04 : P.C.B. contact 0.73 ± 0.025/5 mm. 15 : No contacts 19 : Silver cad plated shell, Gold flash on crimp contacts 20 : Silver cad plated shell, Gold flash on solder contacts 21 : Anodised black DEF 151 type 1 31 : Silver plated contacts, solder style 43 : Silver cad plated shell, Gold flash on P.C.B. contacts 59 : Zinc Cobalt plating with Olive Drab passivate finish 100 : Zinc Cobalt plating with Black Drab passivate finish <p>(For additional modifications and special requirements please consult factory.)</p>							

ABO5

Arrangement specifications

Shell Size	Contact Arrangement	No. of Contacts	Contact Size and Current Rating (AMPS) - at 85°C Ambient				Shell Orientation	Service Rating
			20	16	12	C0-AX		
08	33	3	3 x 5 amps	---	---	---	N, E, F	1
08	04	4	4 x 5 amps	---	---	---	N, E, F	1
08	98	3	3 x 5 amps	---	---	---	N, E, F	1
10	02	2	---	2 x 10 amps	---	---	N, B, C, E, F	2
10	06	6	6 x 5 amps	---	---	---	N, B, C, E, F	1
10	07	7	7 x 5 amps	---	---	---	N, B, C, E, F	1
12	03	3	---	3 x 10 amps	---	---	N, B, C, E, F	2
12	08	8	8 x 5 amps	---	---	---	N, B, C, E, F	1
12	10	10	10 x 5 amps	---	---	---	N, B, C, E, F	1
12	14	14	14 x 5 amps	---	---	---	N, B, C, E, F	1
14	02	2	---	---	2 x 20 amps	---	N, B, C, E, F	2
14	04	4	---	---	4 x 20 amps	---	N, B, C, E, F	2
14	05	5	---	5 x 10 amps	---	---	N, B, C, E, F	2
14	12	12	8 x 5 amps	4 x 10 amps	---	---	N, B, C, E, F	1
14	15	15	14 x 5 amps	1 x 10 amps	---	---	N, B, C, E, F	1
14	19	19	19 x 5 amps	---	---	---	N, B, C, E, F	1
16	08	8	---	8 x 10 amps	---	---	N, B, C, E, F	2
16	26	26	26 x 5 amps	---	---	---	N, B, C, E, F	1
16	19*	19	15 x 5 amps	4 x 10 amps	---	---	N, B, C, E, F	1
16	CX	17	16 x 5 amps	---	---	1 x cable	N, B, C, E, F	1
18	11	11	---	11 x 10 amps	---	---	N, B, C, E, F	2
18	32	32	32 x 5 amps	---	---	---	N, B, C, E, F	1
20	41	41	41 x 5 amps	---	---	---	N, B, C, E, F	1
20	39*	39	37 x 5 amps	2 x 10 amps	---	---	N, B, C, E, F	1
22	55	55	55 x 5 amps	---	---	---	N, B, C, E, F	1
24	61	61	61 x 5 amps	---	---	---	N, B, C, E, F	1

*Consult factory for availability

	Sea Level 1013 mbar		8,500 m (27800 ft.) 300 mbar		20,000 m (66,000 ft.) 44 mbar	
Service Rating	1	2	1	2	1	2
Working Voltage (nominal) d.c. or a.c. peak	700	1200	550	650	330	380
Voltage proof d.c. or a.c. peak	2100	3000	1100	1300	660	760

Current Service Ratings

Contact Size	Max. Current	* Rated Current
20 AWG	7.5A	5A
16 AWG	13A	10A
12 AWG	23A	20A

*Maximum working current per contact when all contacts are working simultaneously at 85°C ambient temperature.

ABO5

Contact specifications

Shell Size 8

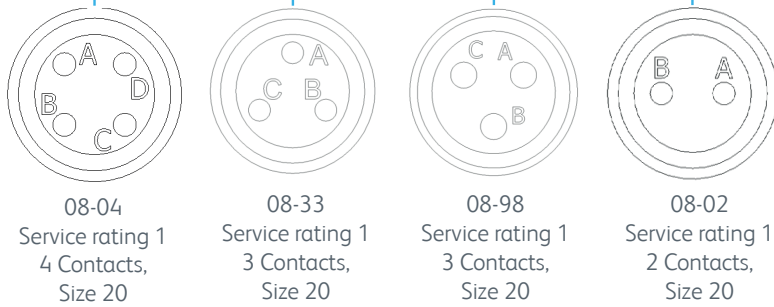

Shell Size 10

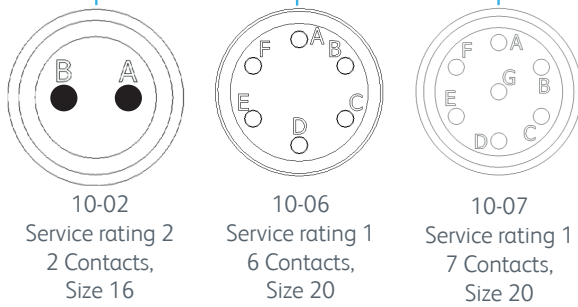



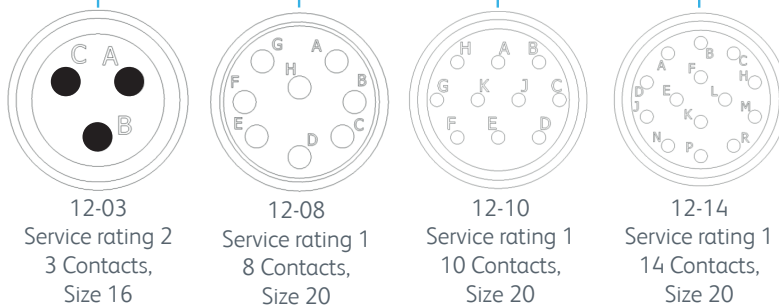

Shell Size 12

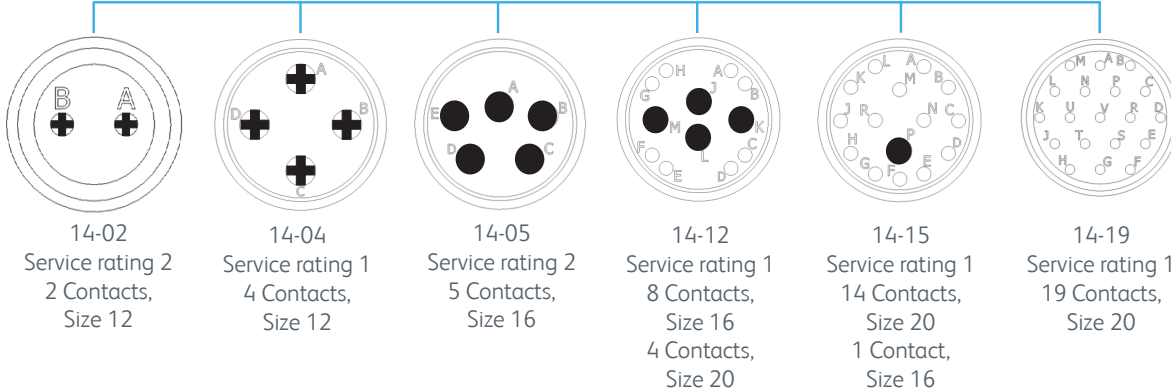

Shell Size 14



-  Size 20 Contacts
-  Size 16 Contacts
-  Size 12 Contacts
-  Size 8 Contacts
-  Co-Axial Contact for RG316/U

Note: Views from front of pin connector inserts

ABO5

Contact specifications

Shell Size 16

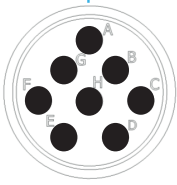

16-08
Service rating 2
8 Contacts,
Size 16

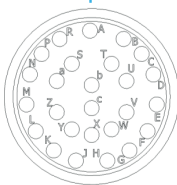

16-26
Service rating 1
26 Contacts,
Size 20



16-19*
Service rating 1
15 Contacts,
Size 20
4 Contacts,
Size 16



16-CX
Service rating 1
17 Contacts,
Size 20
1 Co-Axial Contact,
for RG316/U

Shell Size 18



18-11
Service rating 2
11 Contacts,
Size 16

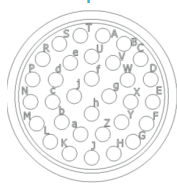

18-32
Service rating 1
32 Contacts,
Size 20

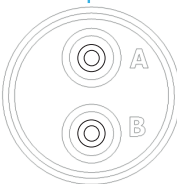

18-02
Service rating 3
2 Contacts,
Size 8

Shell Size 20

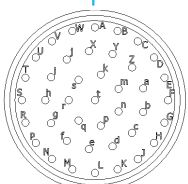

20-41
Service rating 1
41 Contacts,
Size 20

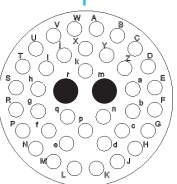

20-39*
Service rating 1
37 Contact,
Size 20
2 Contacts,
Size 16

Shell Size 22

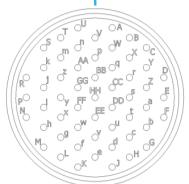

22-55
Service rating 1
55 Contacts,
Size 22

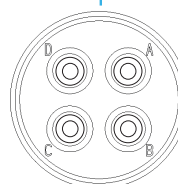





22-04
Service rating 1
4 Contacts,
Size 8

Shell Size 24



24-61
Service rating 1
61 Contact,
Size 24

-  Size 20 Contacts
-  Size 16 Contacts
-  Size 12 Contacts
-  Size 8 Contacts
-  Co-Axial Contact for RG316/U

Note: Views from front of pin connector inserts

AB05-1000

Cable connecting receptacle

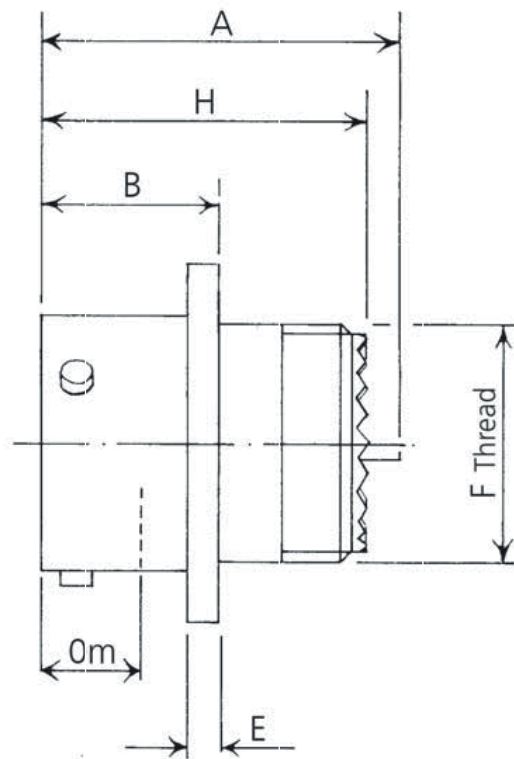
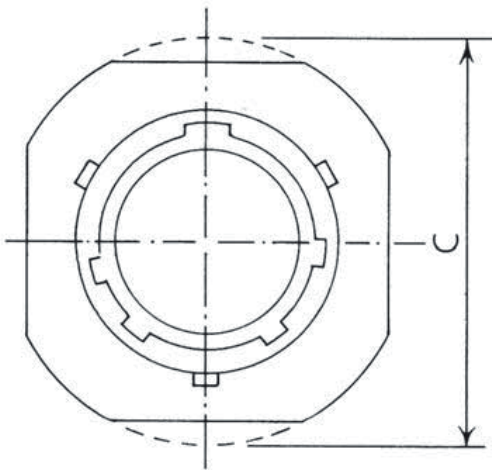

Shell Size	A max.	B max.	C Ø max.	E max.	F thread UNEF 2A	H max.	Om min. overlap	MASS max. G
08	26.40	13.80	24.40	2.80	$7/16$ -28	26.0	7.30	8
10	26.40	13.80	27.70	2.80	$9/16$ -24	26.0	7.30	13
12	26.40	13.80	30.0	2.80	$11/16$ -24	26.0	7.30	17
14	26.40	13.80	32.30	2.80	$13/16$ -20	26.0	7.30	24
16	26.40	13.80	34.80	2.80	$15/16$ -20	26.0	7.30	30
18	26.40	13.80	37.10	2.80	$1\ 1/16$ -18	26.0	7.30	37
20	30.40	17.80	40.40	3.30	$1\ 3/16$ -18	28.50	8.90	59
22	30.40	17.80	43.40	3.30	$1\ 5/16$ -18	28.50	8.90	72
24	30.40	18.60	46.70	3.30	$1\ 7/16$ -18	30.0	8.90	85

Thread measurement is imperial, all other measurements in mm.

AB05-2000

receptacle, square flange with accessory thread

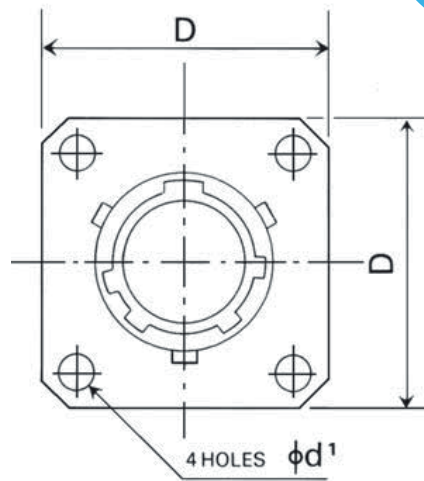
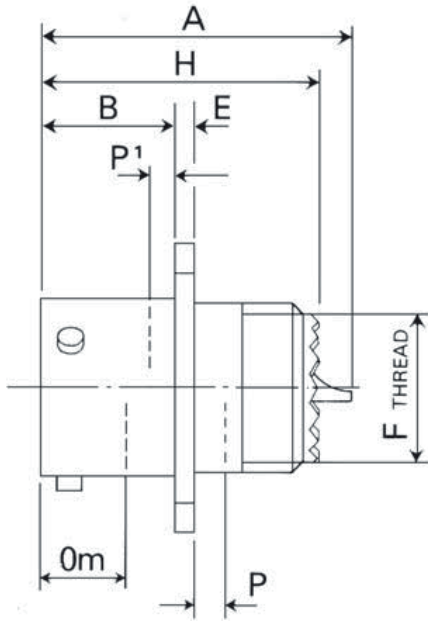

Panel Cut Out Dimensions:

*P Max. Panel Thickness

P Min. Clearance Distance For Mating Connector

Size 8 to 18-2,0 (0,08)

Size 20 to 24-5,3 (0,21)

*P May be increased if 'W' is enlarged to clear accessory

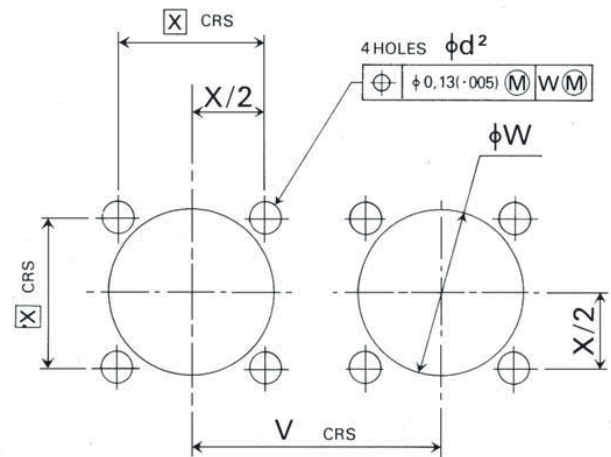

Shell Size	A max.	B max.	D sq. max.	E max.	F thread UNEF 2A	H max.	Om min. overlap	d ¹ Ø min.	d ² Ø min.	V min.	W Ø ±0.13 (.005)	X (TP)	MASS max. G
08	26.40	11.80	21.10	2.0	7/16 -28	26.0	7.30	3.05	3.25	22.60	14.43	15.09	10
10	26.40	11.80	24.40	2.0	9/16 -24	26.0	7.30	3.05	3.25	25.40	17.40	18.26	13
12	26.40	11.80	26.70	2.0	11/16 -24	26.0	7.30	3.05	3.25	29.70	21.95	20.62	16
14	26.40	11.80	29.30	2.0	13/16 -20	26.0	7.30	3.05	3.25	33.0	25.12	23.01	22
16	26.40	11.80	31.50	2.0	15/16 -20	26.0	7.30	3.05	3.25	38.1	28.27	24.61	27
18	26.40	11.80	33.80	2.0	1 1/16 -18	26.0	7.30	3.05	3.25	40.90	31.45	26.97	38
20	30.40	15.0	37.10	2.8	1 3/16 -18	28.5	8.90	3.05	3.25	43.90	34.62	29.36	52
22	30.40	15.0	40.20	2.8	1 5/16 -18	28.5	8.90	3.05	3.25	46.70	37.80	31.75	65
24	30.40	15.80	43.50	2.8	1 7/16 -18	30.0	8.90	3.73	3.86	50.0	41.02	34.93	77

Thread measurement is imperial, all other measurements in mm.

AB05/6

AB05-2100

receptacle, square flange without accessory thread

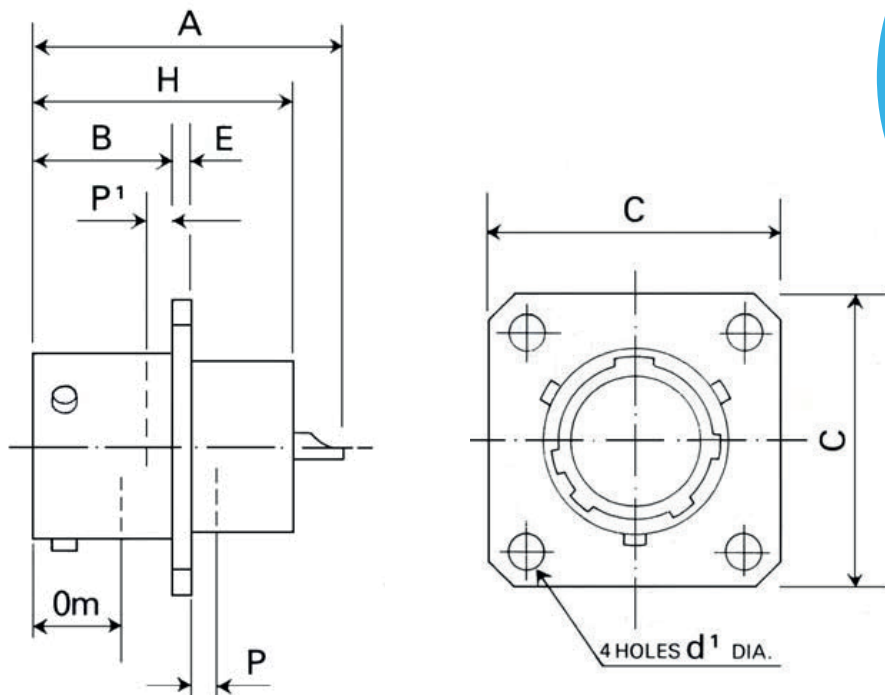
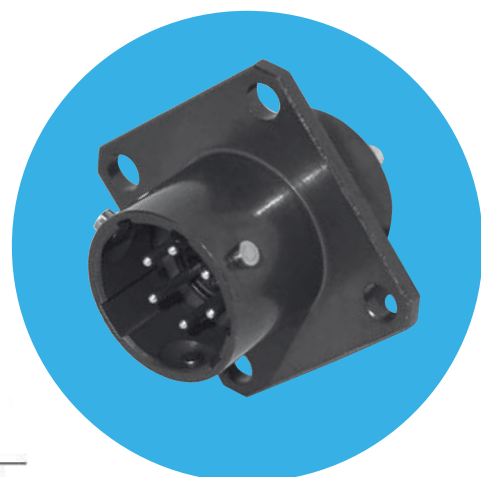

Panel Cut Out Dimensions:

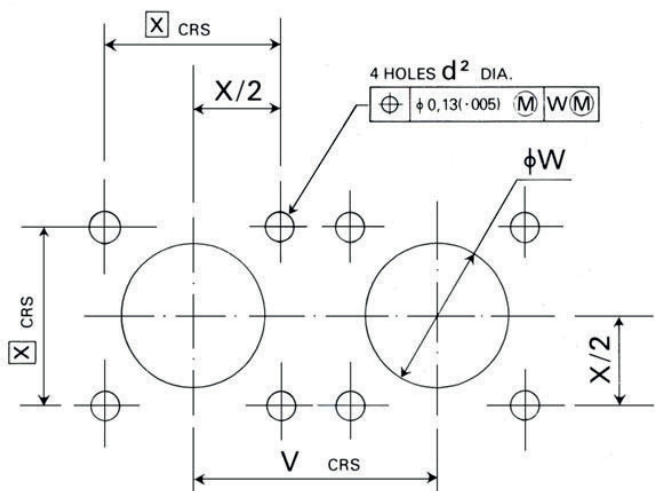

*P Max. Panel Thickness

P Min. Clearance Distance For Mating Connector
 Size 8 to 18-2,0 (0,08)
 Size 20 to 24-5,3 (0,21)

*P May be increased if 'W' is enlarged to clear accessory

Shell Size	A max.	B max.	C max.	E max.	H max.	V CRS min.	W Ø min.	X CRS (TP)	d ¹ Ø ±0.13(0.005)	d ² Ø ±0.13(0.005)	Om min. overlap	P max.	P1 max.	MASS max. G
08	26.40	11.70	21.10	2.0	21.60	22.06	14.43	15.09	3.05	3.12	7.30	8.50	2.21	10
10	26.40	11.70	24.30	2.0	21.60	25.04	17.40	18.26	3.05	3.12	7.30	8.50	2.21	13
12	26.40	11.70	26.60	2.0	21.60	29.07	21.95	20.62	3.05	3.12	7.30	8.50	2.21	18
14	26.40	11.70	29.0	2.0	21.60	33.0	25.12	23.01	3.05	3.12	7.30	8.50	2.21	24
16	26.40	11.70	31.50	2.0	21.60	38.10	28.27	24.61	3.05	3.12	7.30	8.50	2.21	30
18	26.40	11.70	33.80	2.0	21.60	40.09	31.45	26.97	3.05	3.12	7.30	8.50	2.21	39
20	30.40	14.80	37.10	2.80	27.20	43.90	34.62	29.36	3.05	3.12	8.90	8.50	5.38	55
22	30.40	14.80	40.20	2.80	27.20	46.70	37.80	31.75	3.05	3.12	8.90	8.50	5.38	65
24	30.40	15.70	43.50	2.80	28.60	50.0	41.02	34.93	3.73	3.81	8.90	8.50	5.38	77

All measurements in mm.

AB05-3100

Without accessory thread

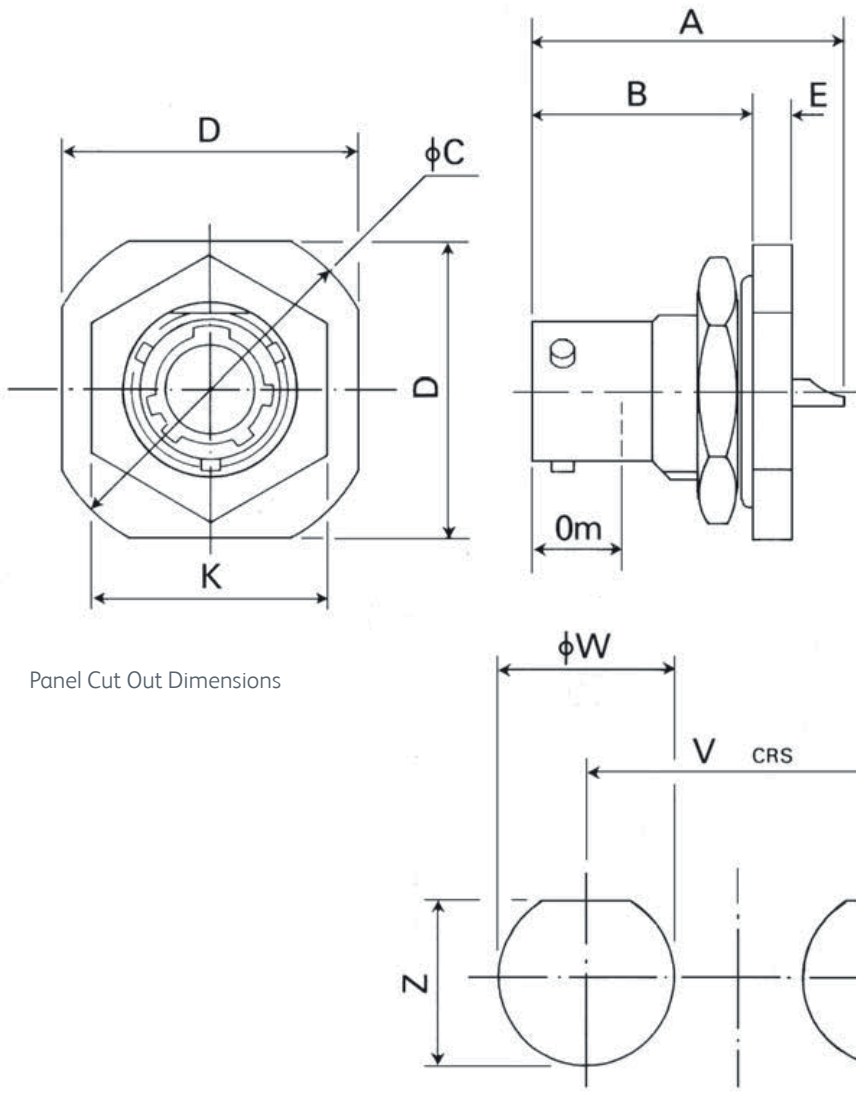

Shell Size	A max.	B max.	C Ø max.	D max.	E max.	K max.	V min.	W Ø ±0.13(005)	Z ±0.13(005)	Om min. overlap	Panel Thickness		MASS max. G
											max.	min.	
08	26.40	18.60	27.50	24.40	3.60	19.60	24.70	14.53	13.72	7.30	3.30	1.50	17
10	26.40	18.60	30.80	27.50	3.60	22.90	28.0	17.70	16.69	7.30	3.30	1.50	20
12	26.40	18.60	35.60	32.30	3.60	27.50	32.80	22.48	21.03	7.30	3.30	1.50	24
14	26.40	18.60	38.70	35.60	3.60	30.80	35.90	25.65	24.18	7.30	3.30	1.50	34
16	26.40	18.60	42.0	38.70	3.60	33.80	39.20	28.83	27.33	7.30	3.30	1.50	43
18	26.40	18.60	45.0	42.0	3.60	37.10	43.0	32.00	30.61	7.30	3.30	1.50	47
20	30.40	23.10	49.80	46.50	4.40	40.20	47.80	35.18	33.73	8.90	6.40	1.50	63
22	30.40	23.10	52.90	49.80	4.40	49.50	50.80	38.35	36.81	8.90	6.40	1.50	74
24	30.40	24.10	56.20	52.90	4.40	46.50	54.20	41.53	40.03	8.90	6.40	1.50	87

All measurements in mm.

AB05-3200

Receptacle, jam nut with external accessory thread

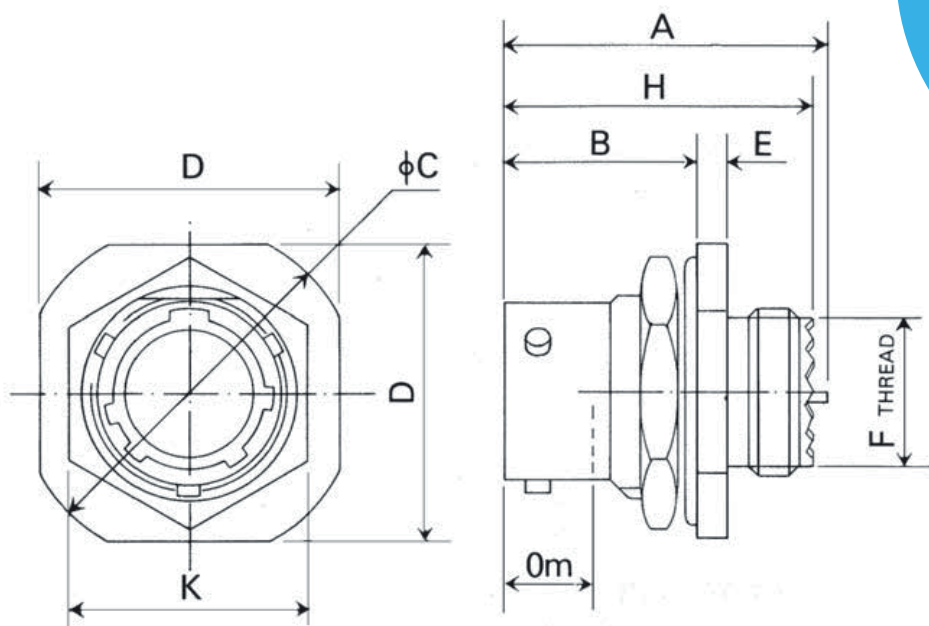

Panel Cut Out Dimensions:

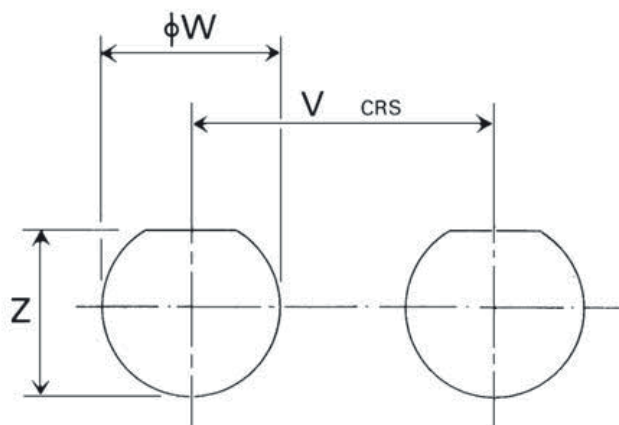

Shell Size	A max.	B max.	C Ø max.	D max.	E max.	F thread UNEF 2A	H max.	K max.	Om min. overlap	Panel Thickness		V	W Ø ±0.13(.005)	Z ±0.13(.005)	MASS max. G
										max.	min.				
08	26.40	15.80	27.50	24.40	3.60	7/16-28	26.0	19.60	7.30	3.30	1.50	24.70	14.53	13.72	21
10	26.40	15.80	30.80	27.50	3.60	9/16-24	26.0	22.90	7.30	3.30	1.50	28.0	17.70	16.89	27
12	26.40	15.80	35.60	32.30	3.60	11/16-24	26.0	27.50	7.30	3.30	1.50	32.80	22.48	21.03	32
14	26.40	15.80	38.70	35.60	3.60	13/16-20	26.0	30.80	7.30	3.30	1.50	35.90	25.65	24.18	47
16	26.40	15.80	42.0	38.70	3.60	15/16-20	26.0	33.80	7.30	3.30	1.50	39.20	28.03	27.33	58
18	26.40	15.80	45.0	42.0	3.60	1 1/16-18	26.0	37.10	7.30	3.30	1.50	43.0	32.0	30.61	62
20	30.40	19.60	49.60	46.50	3.60	1 3/16-18	28.50	40.20	8.90	6.40	1.50	47.80	35.18	33.73	84
22	30.40	19.60	52.90	49.80	4.40	1 5/16-18	28.50	43.50	8.90	6.40	1.50	50.80	38.35	36.81	98
24	30.40	20.90	56.70	52.90	4.40	1 7/16-18	30.0	46.50	8.90	6.40	1.50	54.20	41.53	40.03	116

Thread measurement is imperial, all other measurements in mm.

AB05-6000

plug, knurled coupling nut

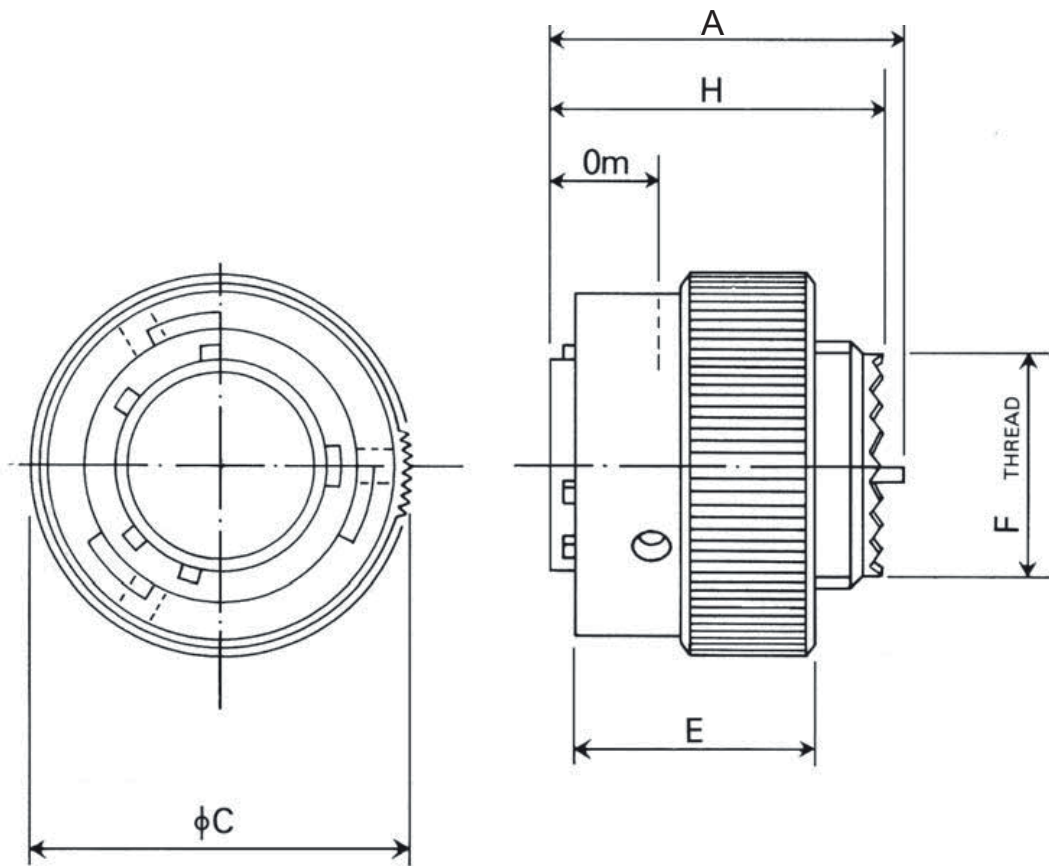

Shell Size	A max.	C ϕ max.	E max.	F thread UNEF 2A	H max.	Om min. overlap	MASS max. G
08	25.40	19.10	19.30	$7/16$ -28	24.40	7.30	12
10	25.40	21.80	19.30	$9/16$ -24	24.40	7.30	15
12	25.40	26.40	19.30	$11/16$ -24	24.40	7.30	20
14	25.40	30.0	19.30	$13/16$ -20	24.40	7.30	27
16	25.40	33.30	19.30	$15/16$ -20	24.70	7.30	35
18	25.40	35.60	19.30	$1 1/16$ -18	24.90	7.30	45
20	27.80	39.10	19.30	$1 3/16$ -18	26.20	8.90	56
22	27.80	42.20	19.30	$1 5/16$ -18	26.20	8.90	65
24	27.80	45.20	20.40	$1 7/16$ -18	28.0	8.90	80

All measurements in mm.

AB05-6100

plug, knurled coupling nut with grounding fingers

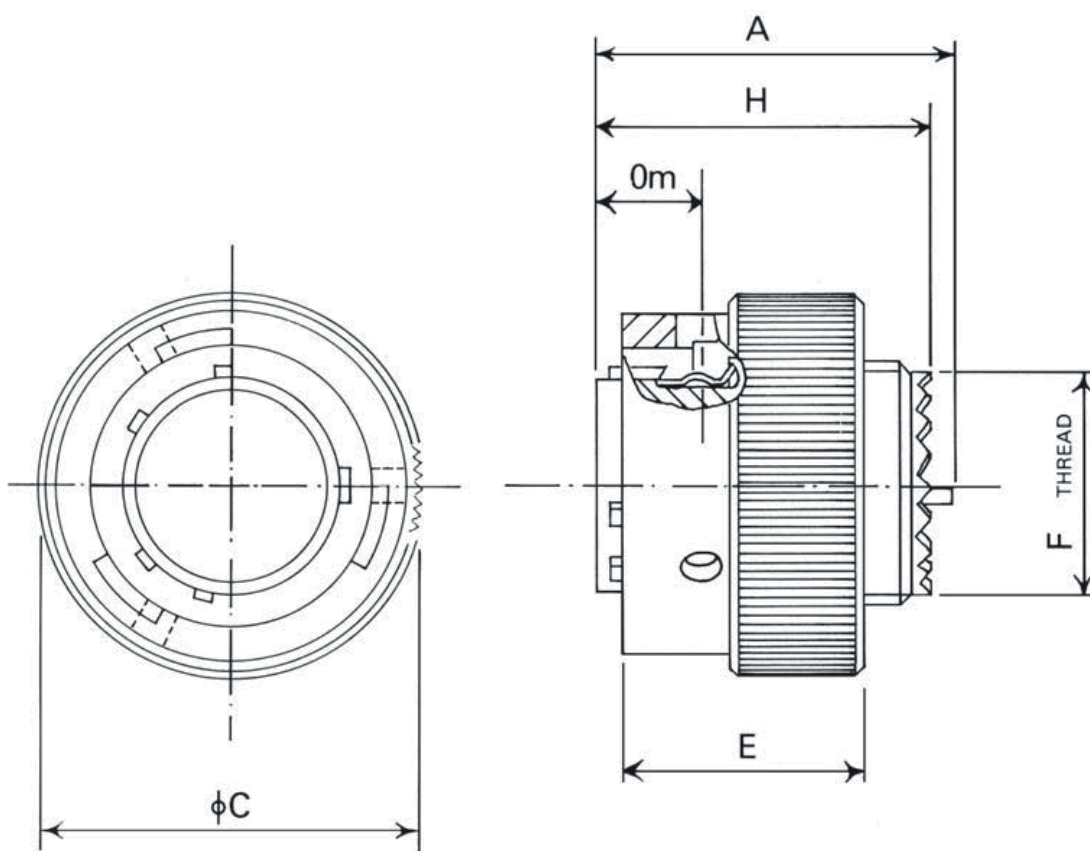

Shell Size	A max.	C ϕ max.	E max.	F thread UNEF 2A	H max.	Om min. overlap	MASS max. G
08	25.40	19.10	19.30	$7/16$ -28	24.40	7.30	12
10	25.40	21.80	19.30	$9/16$ -24	24.40	7.30	15
12	25.40	26.40	19.30	$11/16$ -24	24.40	7.30	20
14	25.40	30.0	19.30	$13/16$ -20	24.40	7.30	27
16	25.40	33.30	19.30	$15/16$ -20	24.70	7.30	35
18	25.40	35.60	19.30	$11/16$ -18	24.90	7.30	45
20	27.80	39.10	19.30	$13/16$ -18	26.20	8.90	56
22	27.80	42.20	19.30	$15/16$ -18	26.20	8.90	65
24	27.80	45.20	20.40	$17/16$ -18	28.0	8.90	80

Thread measurement is imperial, all other measurements in mm.

AB05-6200

plug, course ribbed coupling nut

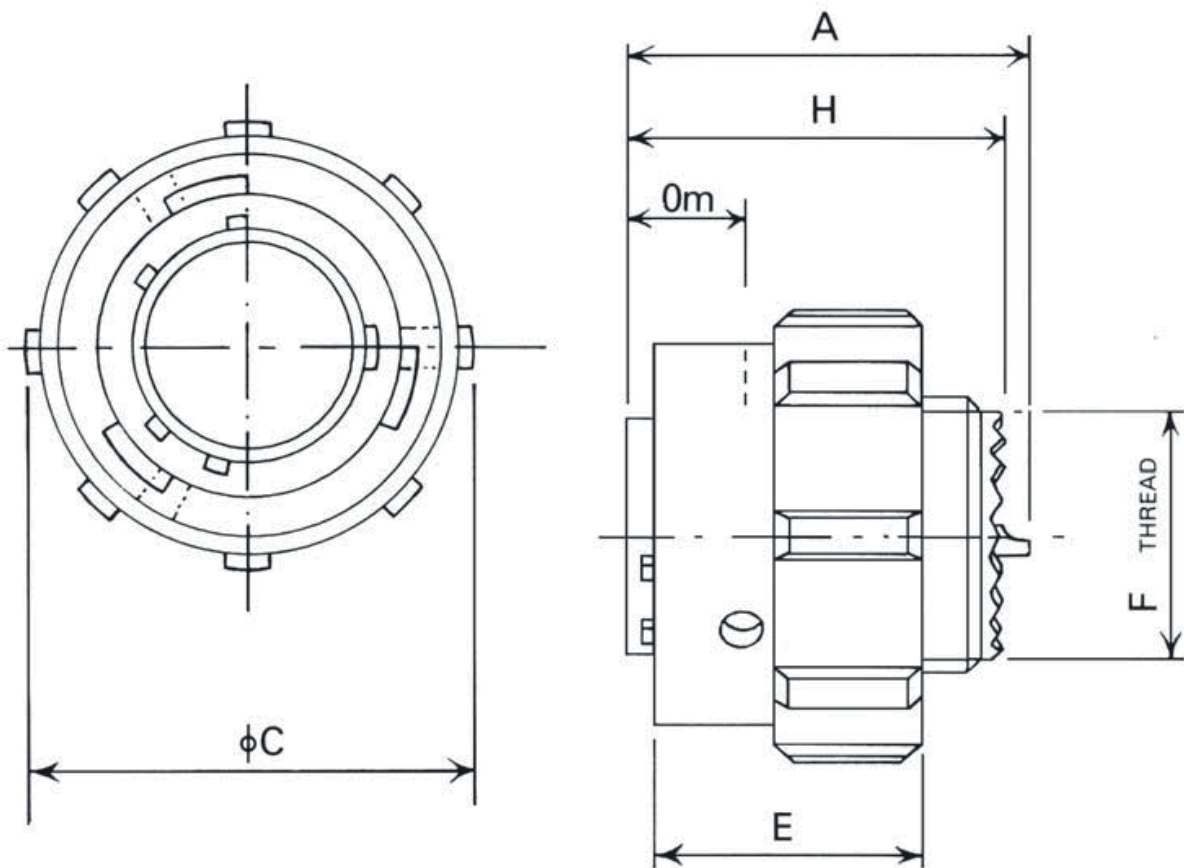

Shell Size	A max.	C ϕ max.	E max.	F thread UNEF 2A	H max.	Om min. overlap	MASS max. G
08	25.40	22.10	20.40	$7/16$ -28	24.40	7.30	13
10	25.40	24.90	20.40	$9/16$ -24	24.40	7.30	17
12	25.40	29.30	20.40	$11/16$ -24	24.40	7.30	22
14	25.40	32.60	20.40	$13/16$ -20	24.40	7.30	28
16	25.40	37.60	20.40	$15/16$ -20	24.70	7.30	38
18	25.40	40.40	20.40	$1 1/16$ -18	24.90	7.30	46
20	27.80	43.50	20.40	$1 3/16$ -18	26.20	8.90	59
22	27.80	46.30	20.40	$1 5/16$ -18	26.20	8.90	63
24	27.80	49.60	21.40	$1 7/16$ -18	28.0	8.90	83

AB05-6300

plug, coarse ribbed coupling nut with grounding fingers

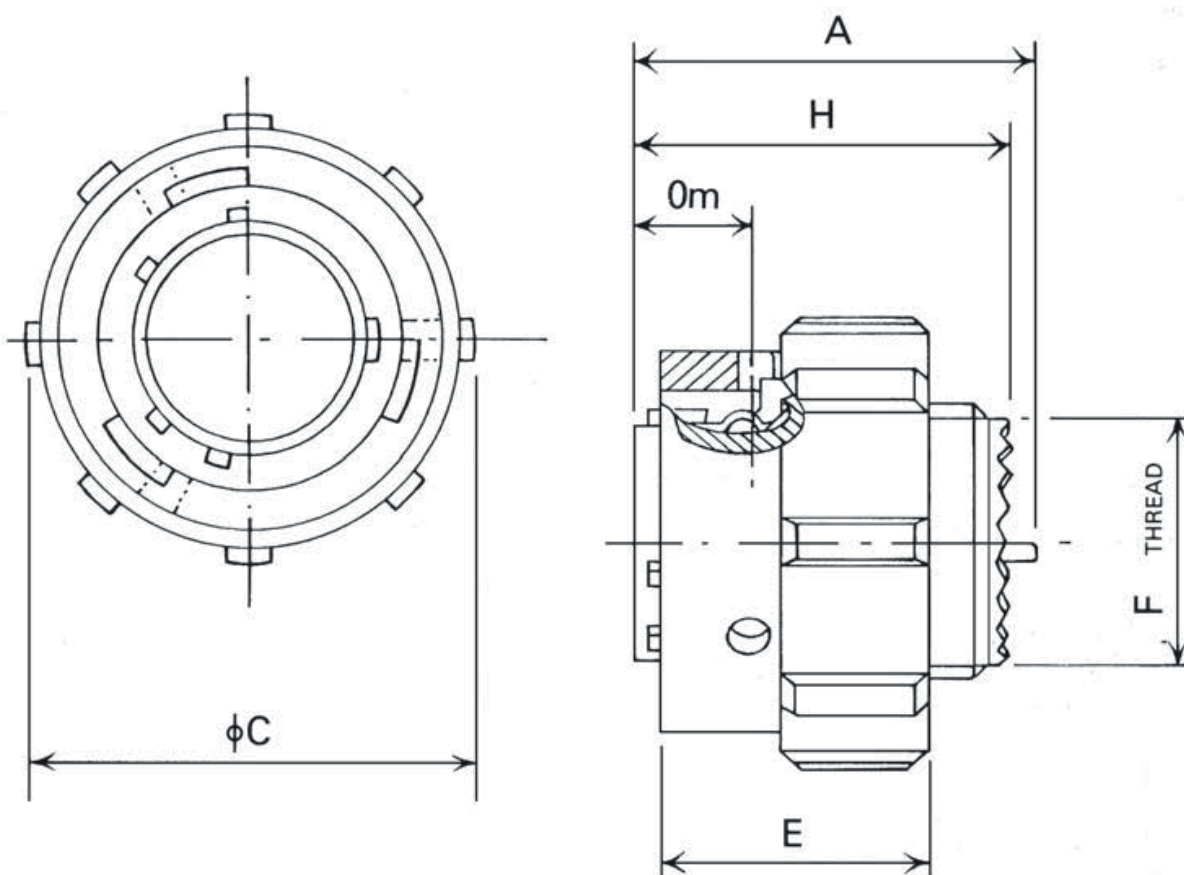
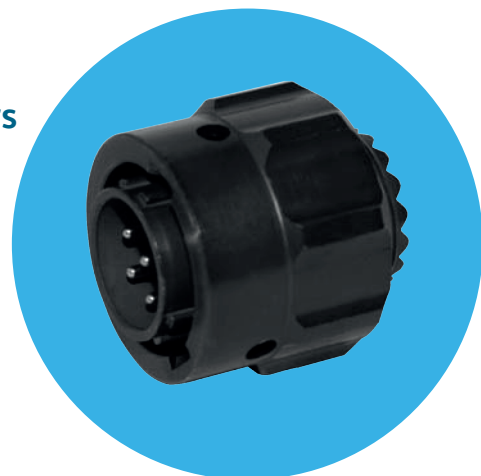

Shell Size	A max.	C ϕ max.	E max.	F thread UNEF 2A	H max.	0m min. overlap	MASS max. G
08	25.40	22.10	20.40	$7/16$ -28	24.40	7.30	13
10	25.40	24.90	20.40	$9/16$ -24	24.40	7.30	17
12	25.40	29.30	20.40	$11/16$ -24	24.40	7.30	22
14	25.40	32.60	20.40	$13/16$ -20	24.40	7.30	28
16	25.40	37.60	20.40	$15/16$ -20	24.70	7.30	38
18	25.40	40.40	20.40	$11/16$ -18	24.90	7.30	46
20	27.80	43.50	20.40	$13/16$ -18	26.20	8.90	59
22	27.80	46.30	20.40	$15/16$ -18	26.20	8.90	63
24	27.80	49.60	21.40	$17/16$ -18	28.0	8.90	83

Thread measurement is imperial, all other measurements in mm.

AB05

accessories part number explanation

Accessories can also be ordered separately.

To illustrate the ordering procedure, part number AB05002710070021 is shown in the table below:

Product Range:	AB05	00	27	10	07	00	21
Shell Style:	00 No connector. Accessory only.						
Accessory Class:	27 : Strain relief clamp 29 : Straight outlet internally screened 30 : Straight outlet externally screened 40 : Grommet nut 50 : General duty adaptor (no grommet necessary) 55 : Sealing gland (no grommet necessary) 62 : Sealing gland with integral cable clamp 65 : Cover for square flange receptacle 66 : Cover for jam nut receptacle 70 : Cover for plug 75 : Screen and heat shrink adaptor 2* : Screening heat shrink adaptor, sealing type (* Indicates Entry Size, see page 29) 3* : Screening heat shrink adaptor 90° outlet, sealing type						
Accessory Size:	08, 10, 12, 14, 16, 18, 20, 22, 24 (Increase in sixteenths of an inch)						
Contact layout:	Refers to grommet where fitted. 00 No grommet supplied.						
Orientation:	00 No orientation.						
Modification:	21 Anodised black def 151 type 1. 59 : Zinc Cobalt plating with Olive Drab passivate finish 100 : Zinc Cobalt plating with Black Drab passivate finish						

AB05-0027

strain relief clamp

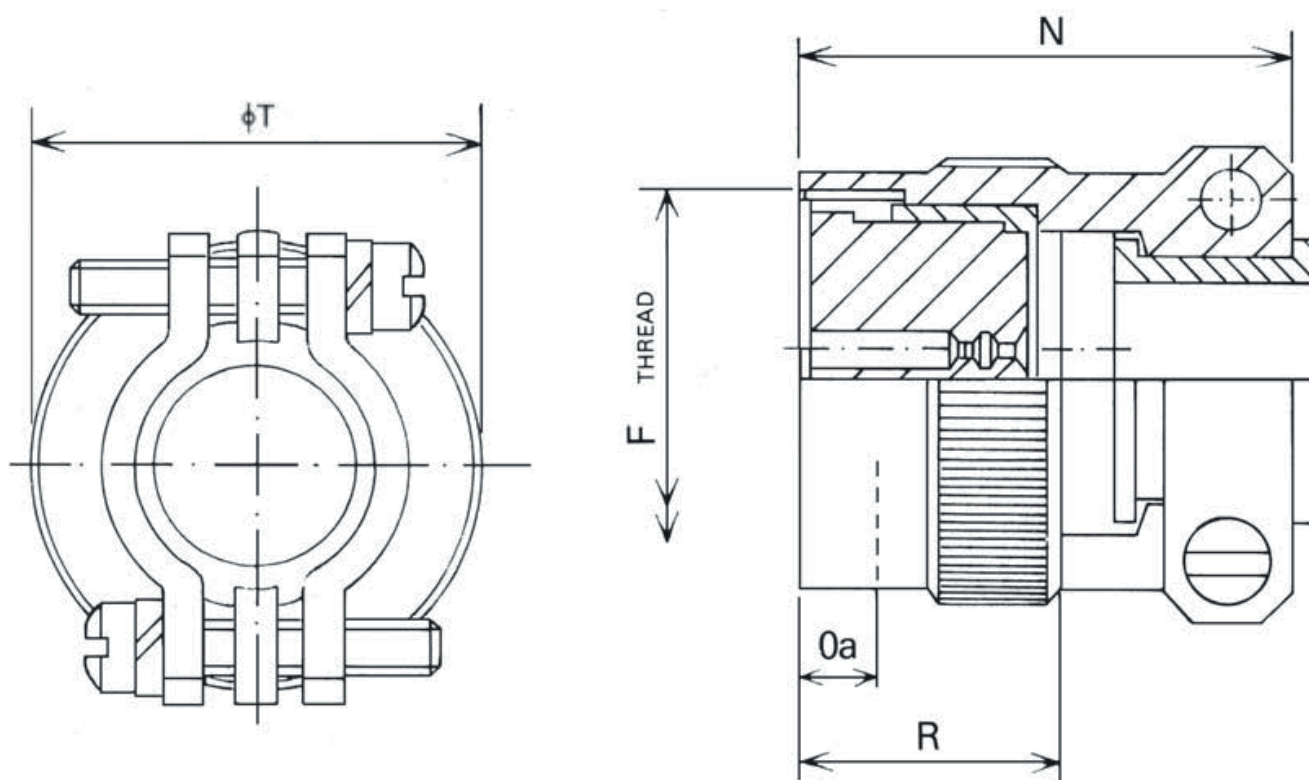

Shell Size	F thread UNEF 2B	N max.	Oa min.	R max.	T ϕ max.	MASS max. G
08	$7/16$ -28	31.40	4.80	16.50	15.20	18
10	$9/16$ -24	31.40	4.80	16.50	18.50	19
12	$11/16$ -24	31.40	4.80	16.50	21.80	20
14	$13/16$ -20	31.40	4.80	16.50	25.10	22
16	$15/16$ -20	33.50	4.80	16.50	28.20	25
18	$1 1/16$ -18	34.30	4.80	16.50	31.50	29
20	$1 3/16$ -18	36.80	4.80	17.20	34.50	31
22	$1 5/16$ -18	36.80	4.80	17.20	37.60	38
24	$1 7/16$ -18	36.80	4.80	17.20	40.90	42

For Accessory Part Number Explanation, see page 18.

Thread measurement is imperial, all other measurements in mm.

AB05-0029

straight outlet for internally screened cable

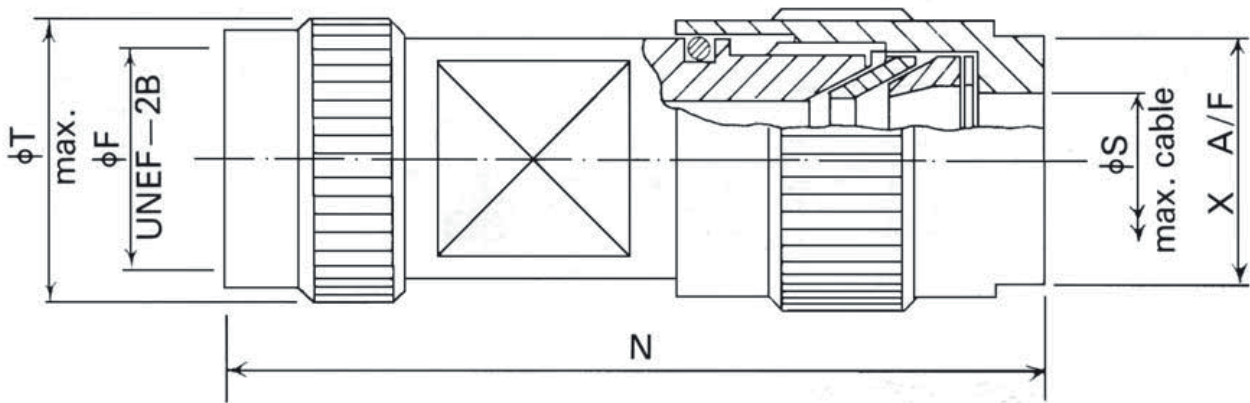
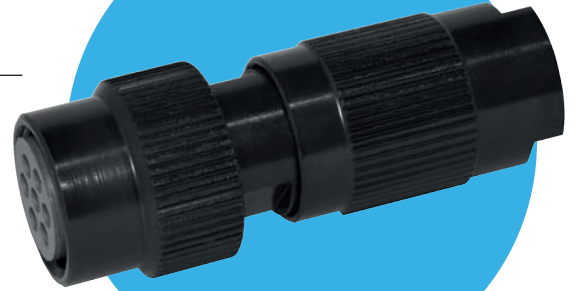

Shell Size	T Ø max.	F thread Ø	N max.	S Ø	X A/F
08	17.53	$7/16 \times 28$	51.30	7.20	12.70
10	19.30	$9/16 \times 24$	51.05	8.70	12.70
12	21.74	$11/16 \times 24$	63.30	7.20; 11.80	15.87
14	26.52	$13/16 \times 20$	63.91	12.50	17.45
16	29.82	$15/16 \times 20$	67.06	14.60	19.05
18	*	*	*	*	*
20	35.66	$13/16 \times 18$	67.06	16.70	25.40
22	*	*	*	*	*
24	42.00	$17/16 \times 18$	76.58	20.30	26.97

For accessory part number explanation, see page 18

*Please consult factory
Thread measurement is imperial, all other measurements in mm.

AB05-0030

straight outlet for externally screened cable

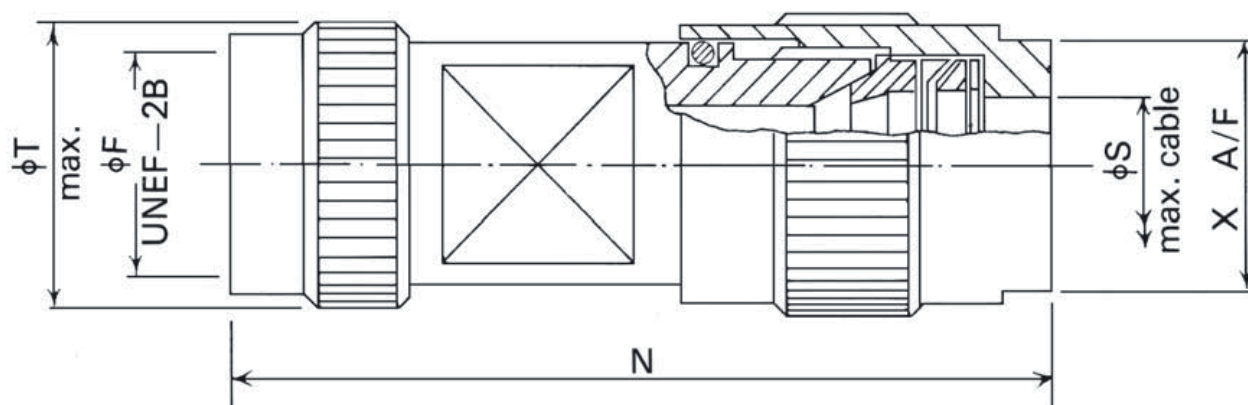

Shell Size	T Ø max.	F thread Ø	N max.	S Ø	X A/F
08	17.53	$7/16 \times 28$	51.30	7.20	12.70
10	19.30	$9/16 \times 28$	51.05	8.70	12.70
12	21.74	$11/16 \times 24$	63.30	7.20; 11.80	15.87
14	26.52	$13/16 \times 20$	63.91	12.50	17.45
16	29.62	$15/16 \times 20$	67.06	14.60	19.05
18	*	*	*	*	*
20	*	*	*	*	*
22	*	*	*	*	*
24	*	*	*	*	*

For accessory part number explanation, see page 18

*Please consult factory

Thread measurement is imperial, all other measurements in mm.

AB05-0040

grommet nut

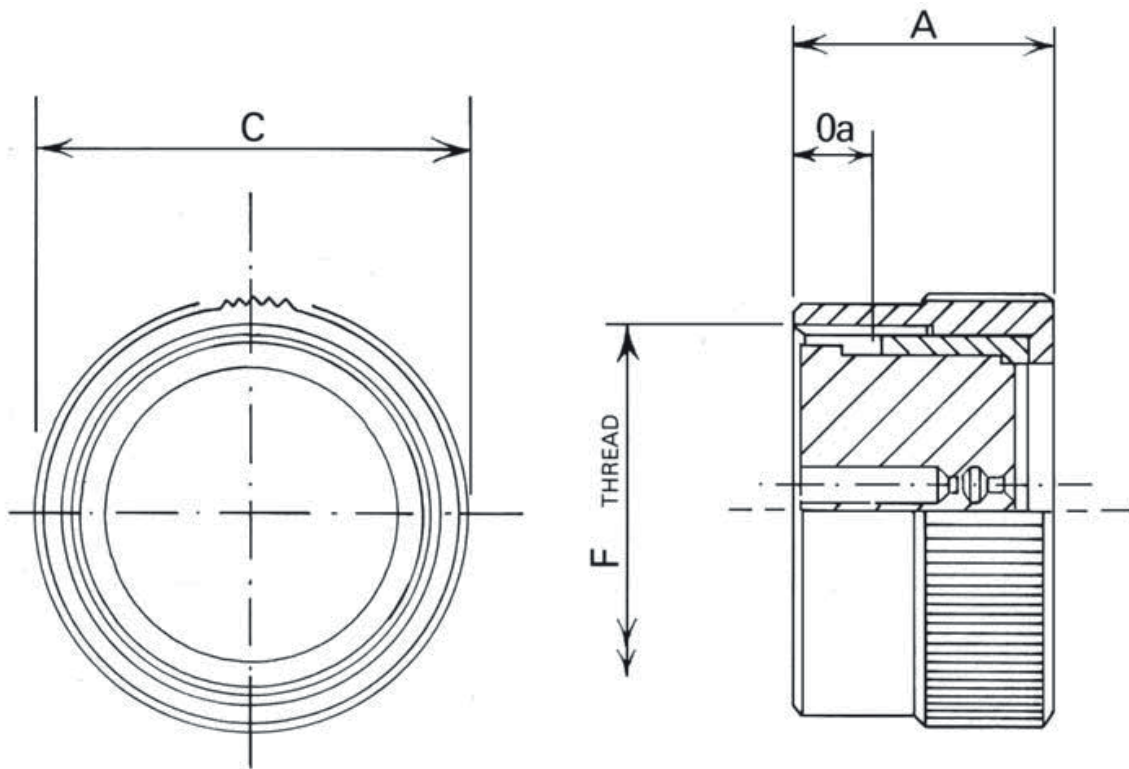

Shell Size	F thread Class 2B	A max.	Oa min. overlap	C Ø max.	MASS max. G
08	7/16 -28 UNEF	16.50	4.80	15.20	7
10	9/16 -24 UNEF	16.50	4.80	18.50	9
12	11/16 -24 UNEF	16.50	4.80	21.80	12
14	13/16 -20 UNEF	16.50	4.80	25.20	14
16	15/16 -20 UNEF	16.50	4.80	28.20	17
18	1 1/16 -18 UNEF	16.50	4.80	31.50	21
20	1 3/16 -18 UNEF	17.20	4.80	34.50	22
22	1 5/16 -18 UNEF	17.20	4.80	37.50	26
24	1 7/16 -18 UNEF	17.20	4.80	40.90	28

For Accessory Part Number Explanation, see page 18.

Thread measurement is imperial, all other measurements in mm.

AB05-0050

general duty adaptor (no grommet necessary)

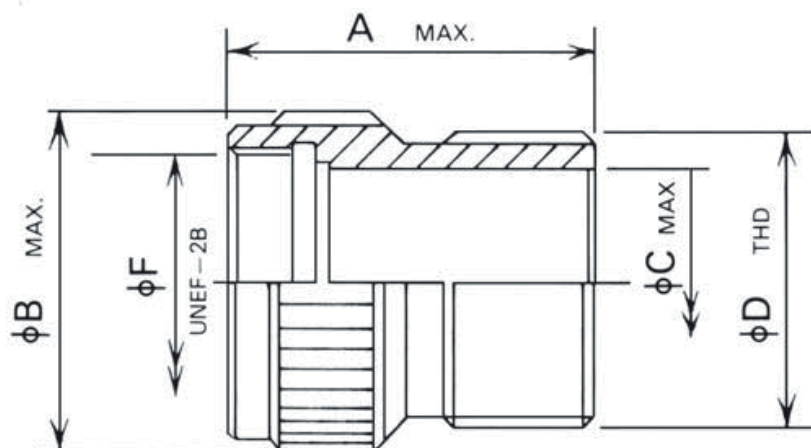

Shell Size	F thread Ø	A	C Ø	B Ø	D thread Ø
08	$7/16 \times 28$	23.75	8.36	14.99	$1/2 \times 28$ UNEF
10	$9/16 \times 24$	23.75	11.35	18.29	$5/8 \times 24$ UNEF
12	$11/16 \times 24$	23.75	14.53	21.59	$3/4 \times 20$ UNEF
14	$13/16 \times 20$	23.75	17.42	24.89	$7/8 \times 20$ UNEF
16	$15/16 \times 20$	23.75	20.60	27.84	1 x 20 UNEF
18	$1 1/16 \times 18$	23.75	23.34	30.73	$1 3/16 \times 18$ NEF
20	$1 3/16 \times 18$	23.75	24.89	34.29	$1 3/16 \times 18$ NEF
22	$1 5/16 \times 18$	23.75	29.69	37.59	$1 7/16 \times 18$ NEF
24	$1 7/16 \times 18$	23.75	31.24	40.64	$1 7/16 \times 18$ NEF

For Accessory Part Number Explanation, see page 18.

Thread measurement is imperial, all other measurements in mm.

AB05-0055

sealing gland (no grommet necessary)

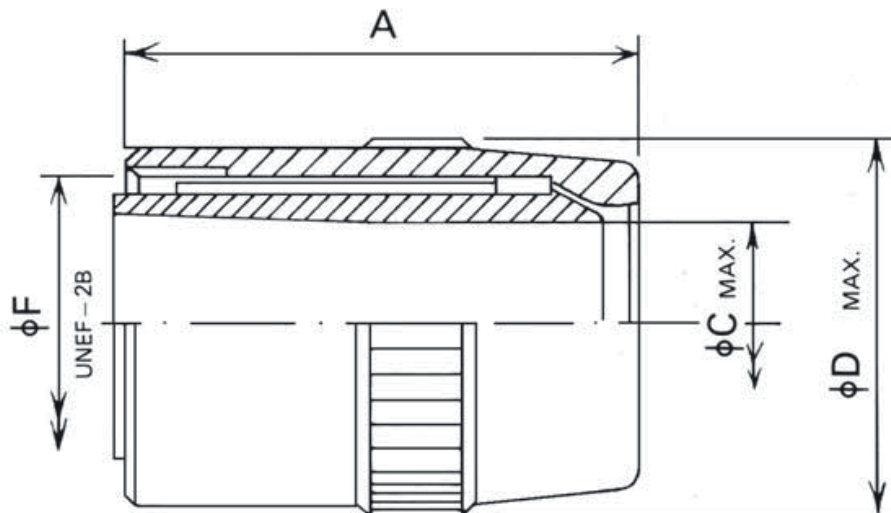

Shell Size	F thread Ø	A	C Ø max.	D Ø max.
08	$7/16 \times 28$	26.80	5.84	14.22
10	$9/16 \times 24$	26.80	7.92	17.37
12	$11/16 \times 24$	29.33	11.23	20.57
14	$13/16 \times 20$	33.02	13.69	23.75
16	$15/16 \times 20$	38.71	15.60	26.92
18	$11/16 \times 18$	43.79	17.07	30.10
20	$13/16 \times 18$	48.90	18.90	33.27
22	$15/16 \times 18$	54.23	21.44	36.45
24	$17/16 \times 18$	55.25	22.61	39.62

For Accessory Part Number Explanation, see page 18.

Thread measurement is imperial, all other measurements in mm.

AB05-0062

sealing gland with integral cable clamp

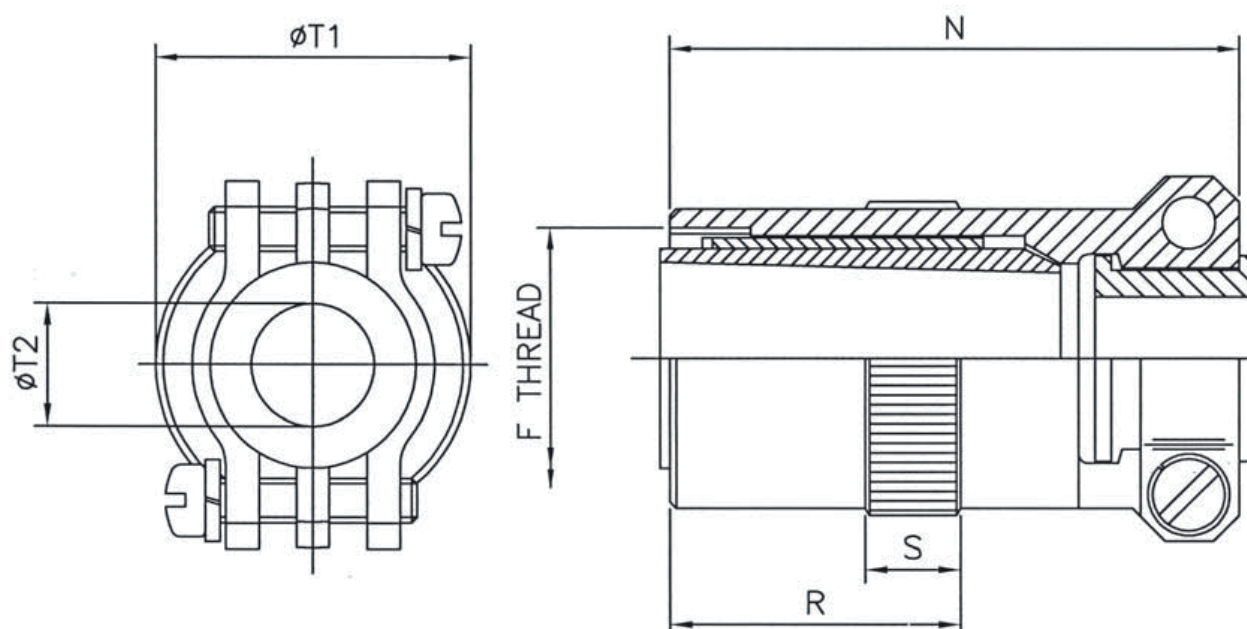

Shell Size	F thread UNEF 2B	N max.	R max.	S max.	T1 ϕ max.	T2 ϕ max.	Closing ϕ of sealing gland
08	$7/16 \times 28$ UNEF	39.20	19.10	5.08	15.0	3.96	4.98
10	$9/16 \times 24$ UNEF	39.20	19.10	5.08	18.30	4.93	5.06
12	$11/16 \times 24$ UNEF	41.80	20.30	5.08	21.60	8.20	9.45
14	$13/16 \times 20$ UNEF	44.70	22.90	7.62	24.90	9.68	11.30
16	$15/16 \times 20$ UNEF	50.80	28.70	8.48	27.90	12.85	14.35
18	$1 1/16 \times 18$ UNEF	55.10	27.40	8.48	30.70	16.03	15.44
20	$1 3/16 \times 18$ UNEF	66.50	27.40	8.48	34.30	16.03	14.96
22	$1 5/16 \times 18$ UNEF	71.90	27.40	8.48	37.60	19.20	15.24
24	$1 7/16 \times 18$ UNEF	72.90	27.40	9.25	40.60	20.47	19.71

* Please consult factory

For Accessory Part Number Explanation, see page 18.

Thread measurement is imperial, all other measurements in mm.

AB05-0065

cover for square flange receptacle

AB05-0066

cover for jam nut receptacle



AB05-0065

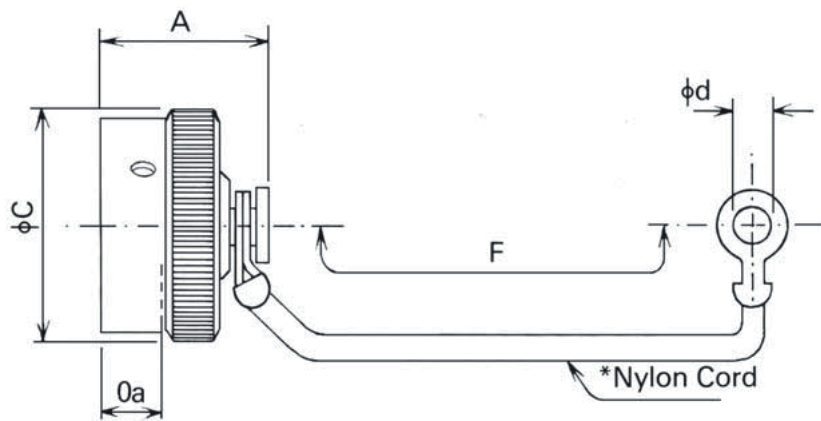

AB05-0066

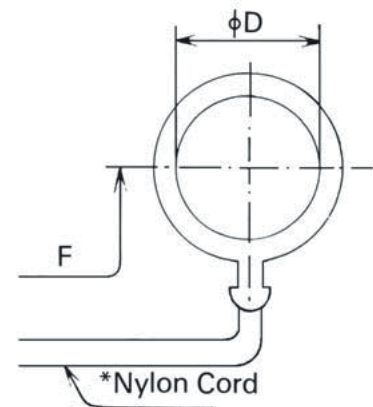

* Part number for cover with Ball Chain Attachment is AB05 0067 & AB05 0068 respectively.

Shell Size	A max.	C Ø max.	d Ø min.	D Ø min.	F approx.	Oa min.	MASS max. G
08	20.10	19.10	3.05	14.50	76.0	7.30	10
10	20.10	21.80	3.05	17.80	76.0	7.30	11
12	20.10	26.40	3.05	22.40	89.0	7.30	14
14	20.10	30.0	3.05	25.70	89.0	7.30	16
16	20.10	33.30	3.05	28.70	89.0	7.30	18
18	20.10	35.60	3.05	32.0	89.0	7.30	20
20	21.60	39.10	3.05	35.10	102.0	7.30	24
22	21.60	42.20	3.05	38.40	102.0	7.30	25
24	22.40	45.20	3.73	41.40	102.0	8.90	29

For Accessory Part Number Explanation, see page 18.
All measurements in mm.

AB05-0070

cover for plug

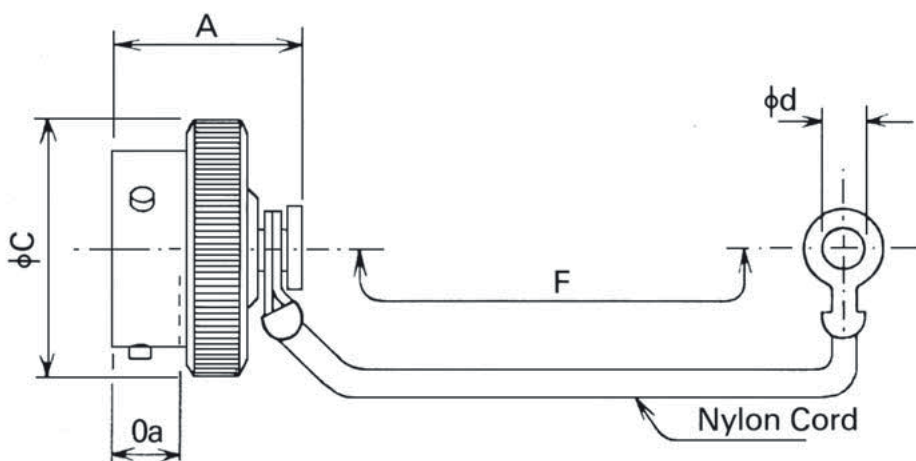

* Part number for cover with Ball Chain Attachment is AB05 0072.

Shell Size	A max.	C Ø max.	d Ø min.	F approx.	Oa min. overlap	MASS max. G
08	20.10	19.10	3.05	76.0	7.30	8
10	20.10	21.80	3.05	76.0	7.30	9
12	20.10	26.40	3.05	89.0	7.30	11
14	20.10	30.0	3.05	89.0	7.30	13
16	20.10	33.30	3.05	89.0	7.30	15
18	20.10	35.60	3.05	89.0	7.30	17
20	21.80	39.10	3.05	102.0	7.30	24
22	21.80	42.20	3.05	102.0	7.30	27
24	22.40	45.20	3.73	102.0	8.90	30

For Accessory Part Number Explanation, see page 18.
All measurements in mm.

AB05-0075

screen and heat shrink adaptor

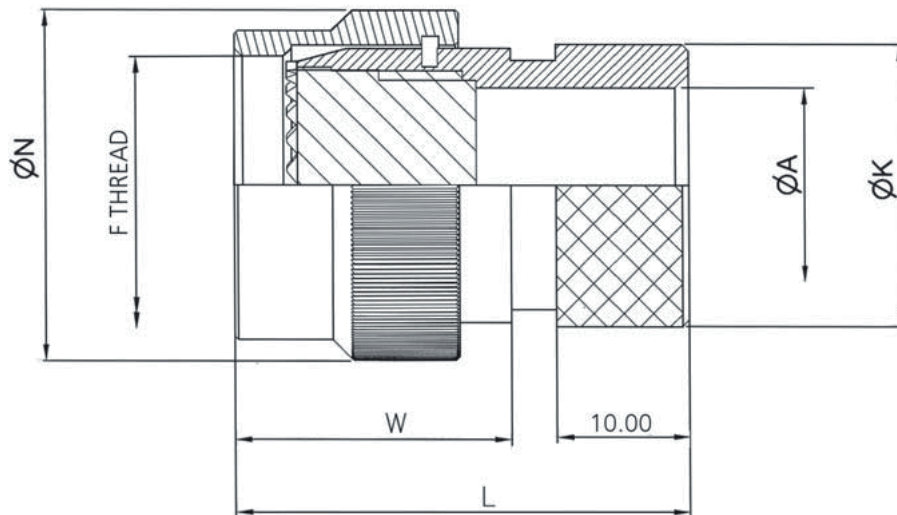

Shell Size	F thread UNEF 2B	A \varnothing max.	K \varnothing max.	N \varnothing max.	W max.	L max.
08	$7/16 \times 28$	5.59	13.46	15.20	16.50	35.51
10	$9/16 \times 24$	8.56	15.24	18.50	16.50	35.51
12	$11/16 \times 24$	11.76	19.56	21.80	16.50	35.51
14	$13/16 \times 20$	14.66	21.29	25.20	16.50	35.51
16	$15/16 \times 20$	17.73	24.36	28.20	16.50	35.51
18	$11/16 \times 18$	20.32	26.42	31.50	16.50	35.51
20	$13/16 \times 18$	22.91	29.54	34.50	17.20	35.51
22	$15/16 \times 18$	26.57	32.66	37.50	17.20	35.51
24	$17/16 \times 18$	28.35	35.22	40.90	17.20	35.51

For Accessory Part Number Explanation, see page 18.

Thread measurement is imperial, all other measurements in mm.

AB05-002*

screening heat shrink adaptor, sealing type

* Indicates Entry Size

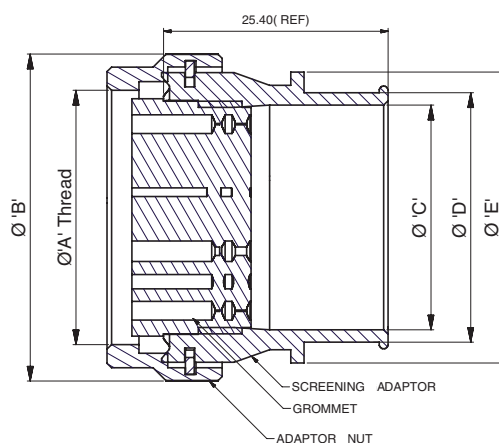
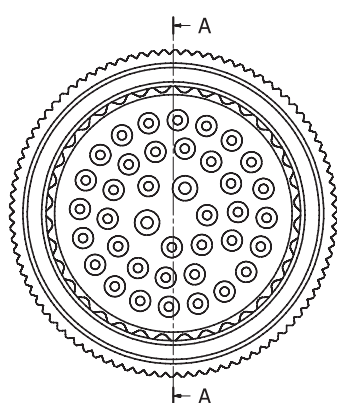

Shell Size	A thread UNEF 2B	B max.	Entry Range
08	7/16 - 28	22.0	03 - 07
10	9/16 - 24	22.0	03 - 10
12	11/16 - 24	26.2	03 - 16
14	13/16 - 20	29.20	03 - 18
16	15/16 - 20	32.20	03 - 20
18	1 1/16 - 18	35.20	03 - 22
20	1 3/16 - 18	39.20	03 - 24
22	1 5/16 - 18	42.20	03 - 24
24	1 7/16 - 18	48.20	03 - 24

Entry Size	C	D Knurl	E max.
03	4.77	9.75	13.90
04	6.35	9.75	13.90
05	7.92	10.72	15.50
06	9.52	12.32	17.20
07	11.10	13.90	18.70
08	12.70	15.50	20.30
09	14.27	17.07	21.90
10	15.88	18.68	23.50
11	17.47	20.27	25.10
12	19.05	21.85	26.70
13	20.62	23.42	28.30

Entry Size	C	D Knurl	E max.
14	22.23	25.03	29.90
15	23.82	26.62	31.50
16	25.40	28.20	33.10
17	27.00	29.80	34.70
18	28.60	31.40	36.30
19	30.20	33.00	37.90
20	31.80	34.60	39.50
21	33.38	36.18	41.10
22	35.00	37.80	42.70
23	36.58	39.38	44.30
24	38.10	40.90	45.90

For Accessory Part Number Explanation, see page 18.

Thread measurement is imperial, all other measurements in mm.

AB05-003*

screening heat shrink adaptor 90° outlet, sealing type

* Indicates Entry Size

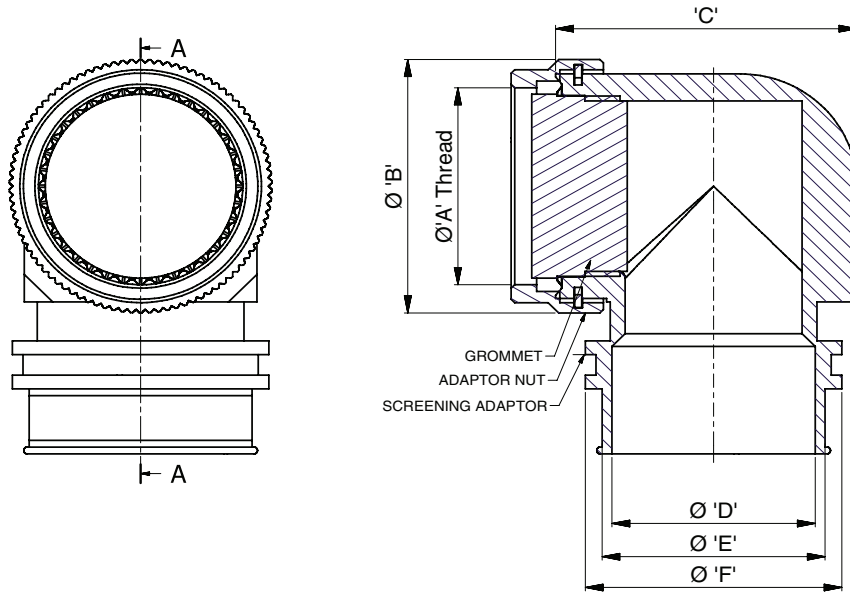

Shell Size	A thread UNEF 2B	B max.	Entry Range
08	7/16 - 28	22.0	03 - 07
10	9/16 - 24	22.0	03 - 10
12	11/16 - 24	26.2	03 - 16
14	13/16 - 20	29.20	03 - 18
16	15/16 - 20	32.20	03 - 20
18	1 1/16 - 18	35.20	03 - 22
20	1 3/16 - 18	39.20	03 - 24
22	1 5/16 - 18	42.20	03 - 24
24	1 7/16 - 18	48.20	03 - 24

Entry Size	D	E Knurl	F max.
03	4.77	9.75	13.90
04	6.35	9.75	13.90
05	7.92	10.72	15.50
06	9.52	12.32	17.20
07	11.10	13.90	18.70
08	12.70	15.50	20.30
09	14.27	17.07	21.90
10	15.88	18.68	23.50
11	17.47	20.27	25.10
12	19.05	21.85	26.70
13	20.62	23.42	28.30

Entry Size	C	D Knurl	E max.
14	22.23	25.03	29.90
15	23.82	26.62	31.50
16	25.40	28.20	33.10
17	27.00	29.80	34.70
18	28.60	31.40	36.30
19	30.20	33.00	37.90
20	31.80	34.60	39.50
21	33.38	36.18	41.10
22	35.00	37.80	42.70
23	36.58	39.38	44.30
24	38.10	40.90	45.90

For Accessory Part Number Explanation, see page 18.

Thread measurement is imperial, all other measurements in mm.

AB06-size-240

filler plug

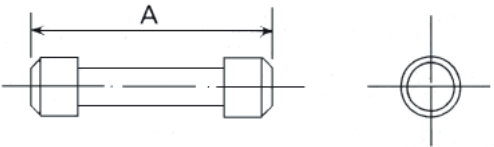
	Contact Size	Colour code	A max.	MASS g x 10
	20	Red	9.90	0.40
	ABB16KFP	Blue	12.20	1.0
	12	Please consult factory		

AB05-size-382

panel gasket

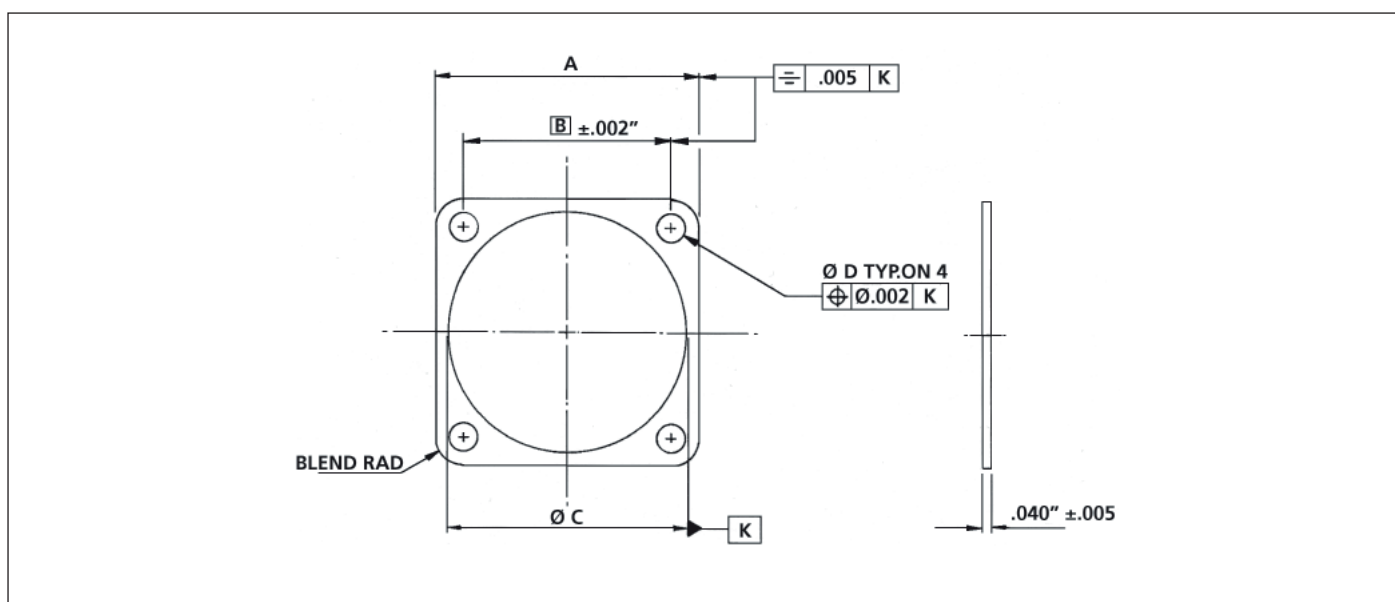

Shell Size	A	B	$\varnothing C$ +0.15 -0	D \varnothing
08	20.98	15.08	11.12	3.42
10	25.40	18.26	14.30	3.42
12	27.78	20.62	17.47	3.42
14	30.17	23.01	20.65	3.42
16	32.53	24.61	23.82	3.42
18	34.92	26.97	27.00	3.42
20	38.10	29.36	30.17	3.42
22	41.27	31.75	33.35	3.42
24	44.45	34.92	36.52	4.14

All measurements in mm.

AB05-size-430

cable grommet

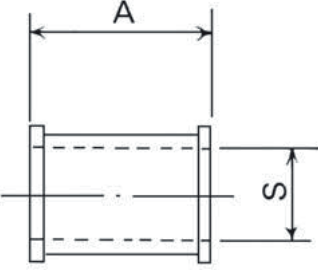
	Shell Size	A max.	S Ø max.	MASS max. G
	08	12.70	4.10	0.70
	10	12.70	5.10	0.90
	12	12.70	8.40	1.30
	14	12.70	9.90	2.20
	16	12.70	13.0	1.90
	18	14.50	16.30	2.70
	20	14.50	16.30	2.70
	22	14.50	19.30	4.60
24	14.50	20.60	4.60	

AB05-2300-size

square flange storage receptacle

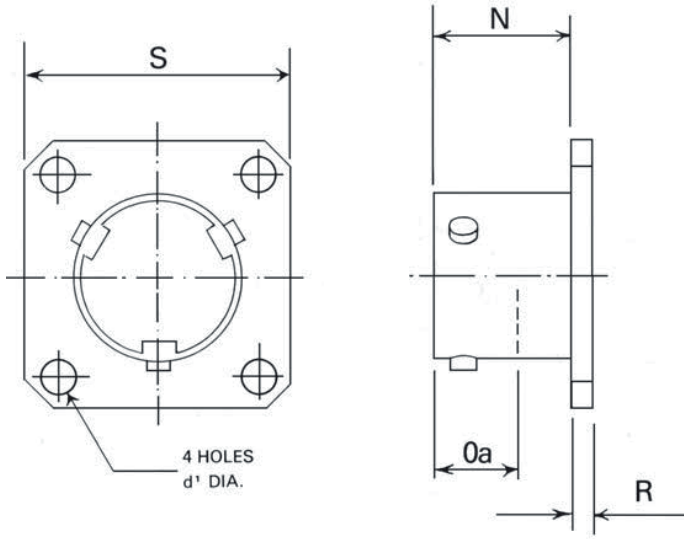

	Shell Size	N max.	Oa min.	R max.	V CRS (TP)	X CRS (TP)	S max.	d ¹ Ø	d ² Ø
	08	12.50	7.50	2.0	22.60	15.09	21.10	3.05	3.12
10	12.50	7.50	2.0	25.40	18.26	24.40	3.05	3.12	
12	12.50	7.50	2.0	29.70	20.62	26.70	3.05	3.12	
14	12.50	7.50	2.0	33.0	23.01	29.20	3.05	3.12	
16	12.50	7.50	2.0	38.10	24.61	31.50	3.05	3.12	
18	12.50	7.50	2.0	40.90	26.97	33.80	3.05	3.12	
20	14.90	9.10	2.80	43.90	29.36	37.0	3.05	3.12	
22	14.90	9.10	2.80	46.70	31.75	40.10	3.05	3.12	
24	15.70	9.10	2.80	50.0	34.93	43.40	3.73	3.81	

All measurements in mm.

AB05

printed circuit board contacts

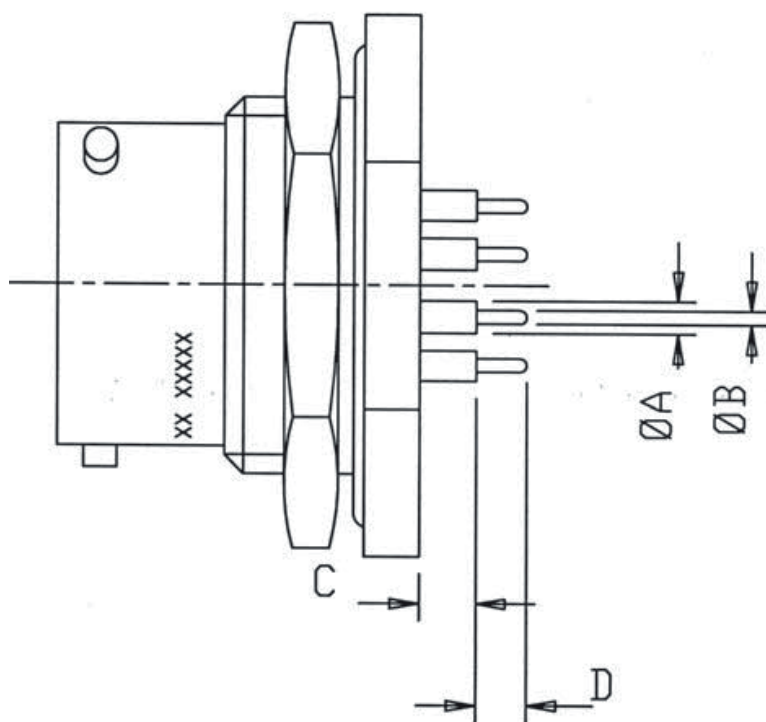

Modification Code	Shell Size	Ø A	Ø B	C	D ^{±0.10}
03	08 - 18	1.50 ^{±0.05}	0.74 ^{±0.03}	3.05/1.52	2.00
03	20 - 22	1.50 ^{±0.05}	0.74 ^{±0.03}	2.84/1.32	2.00
03	24	1.50 ^{±0.05}	0.74 ^{±0.03}	1.93/0.48	2.00
04	08 - 18	1.50 ^{±0.05}	0.74 ^{±0.03}	3.05/1.52	5.00
04	20 - 22	1.50 ^{±0.05}	0.74 ^{±0.03}	2.84/1.32	5.00
04	24	1.50 ^{±0.05}	0.74 ^{±0.03}	1.93/0.48	5.00
05*	08 - 18	2.03 ^{±0.10}	1.02 ^{±0.10}	3.81/2.28	2.29
06*	08 - 18	2.03 ^{±0.10}	0.69 ^{±0.03}	3.81/2.28	2.29
46*	08 - 18	1.90 ^{±0.20}	0.77 ^{±0.17}	1.03/0.50	2.50
62*	08 - 18	1.90 ^{±0.20}	0.80 ^{±0.10}	4.45/2.93	3.00
89*	08 - 18	1.50 ^{±0.05}	0.74 ^{±0.03}	3.05/1.52	3.00
91*	08 - 18	1.50 ^{±0.05}	0.74 ^{±0.03}	2.92/1.39	6.35
96*	08 - 18	2.03 ^{±0.10}	0.69 ^{±0.03}	2.55/1.02	5.00

* Please consult factory

N.B. Dimensions shown above are for AB05 3100 Style connectors only. For other styles please consult factory.
All measurements

AB05

crimp contacts and assembly tools

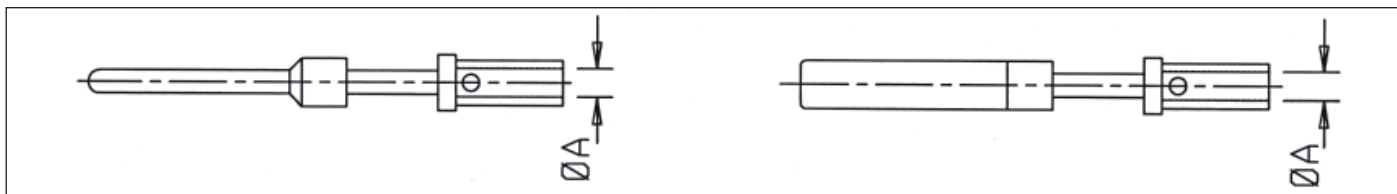

Contact Size AWG	AB Part Number	Pin / Socket	A \varnothing	Conductor Sizes AWG	Shell Sizes
20	AB05-20-110GM	Pin	0.84	28, 26, 24, 22	08 - 18
20	AB05-20-111GM	Pin	0.84	28, 26, 24, 22	20 - 24
16	AB05-16-112GM	Pin	1.75	16	08 - 18
20	AB05-20-112GM	Pin	1.24	20	08 - 18
20	AB05-20-113GM	Pin	1.24	20	20 - 24
20	AB05-20-114GM	Pin	1.35	18	08 - 18
20	AB05-20-115GM	Pin	1.35	18	20 - 24
20	AB05-151-20	Socket	1.83	14	08 - 18
20	AB05-103-20	Socket	0.84	28, 26, 24, 22	08 - 18
20	AB05-152-20	Socket	0.84	28, 26, 24, 22	20 - 24
16	AB05-103-16	Socket	1.75	16	08 - 18
20	AB05-104-20	Socket	1.24	20	08 - 18
20	AB05-153-20	Socket	1.24	20	20 - 24
20	AB05-154-20	Socket	1.35	18	20 - 24
20	AB05-156-20	Socket	1.35	18	08 - 18

Crimp tool and Positioner

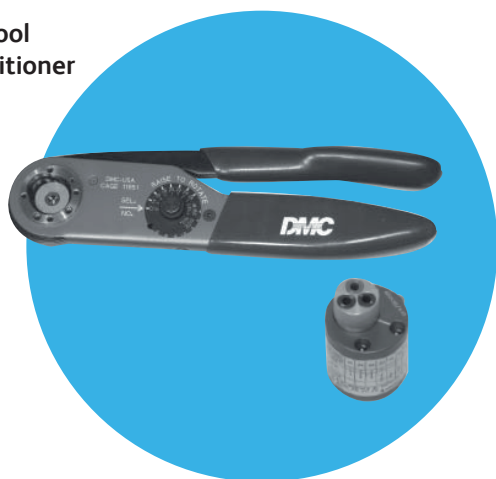

Description	Part No.
Crimp Tool	ABBAF8 (M22520/01-01)
Positioner size 20 Pin and Socket	ABBTH1A
Positioner size 16 Pin and Socket	ABBTP1251

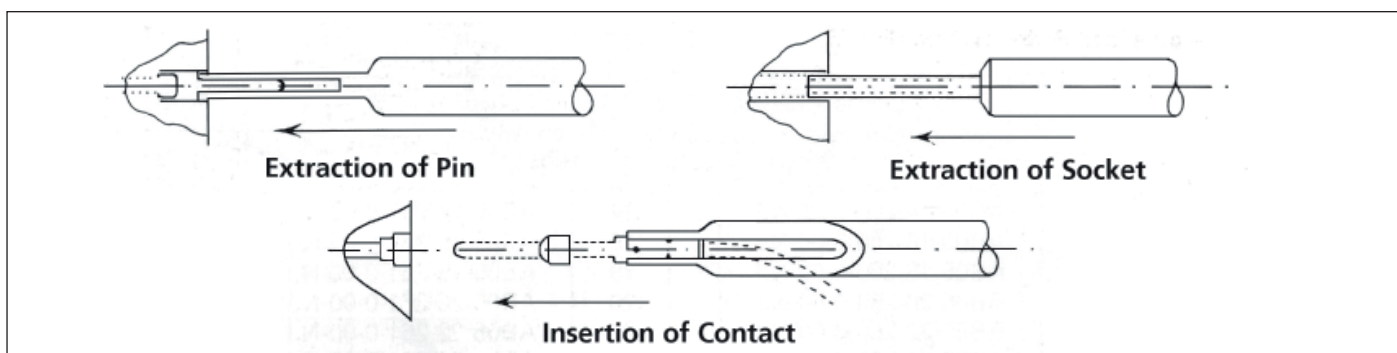
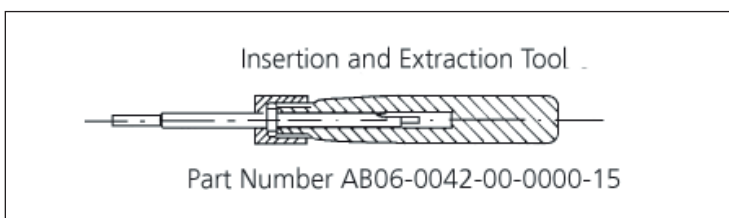

AB05 - 0029

assembly procedure for straight outlets

AB05-0029 Internally Screened Cable

Type C

- Strip PVC sheath back to Dim A, this will expose the Braid which is to be trimmed to within 19.8 mm (0.75") of PVC Sheath and the remainder folded back. (Fig. 1).

Size	Dimension A
08	34.93 (1.375)
10	36.51 (1.437)
12-14	41.27 (1.625)
16-20	44-45 (1.750)
22-24	49.21 (1.937)

- Strip 5.3 mm (0.210") to 6.1 mm (0.240") of insulation from each wire and Tin Ends. (Fig. 2).

- Slide onto the cable (1) Nut; (2) Washer; (3) Gasket; (4) Braid Clamp; (5) Clamp Body; (6) Grommet. (Fig. 3).

- Insert individual wires into Grommet. Slide Grommet back as far as possible. Insert Tinned Ends into Contacts and solder. Slide Grommet over Contacts pushing firmly against rear of connector insert. (Fig. 4).

- Screw clamp body onto Connector. Fold Braid at right angles to cable and slide forward Braid Clamp. Smooth down and trim surplus Braid. Slide up Gasket Washer and Screw on Nut. (Fig. 5)

Fig.1

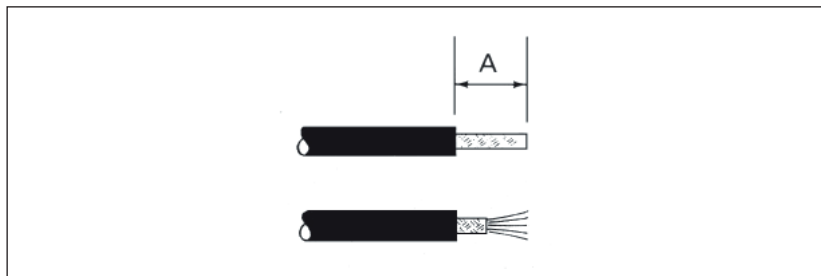

Fig.2

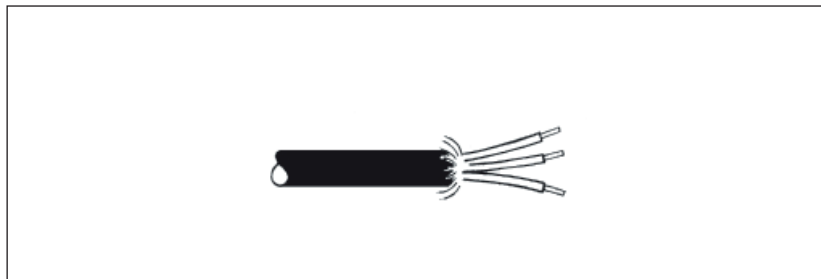

Fig.3

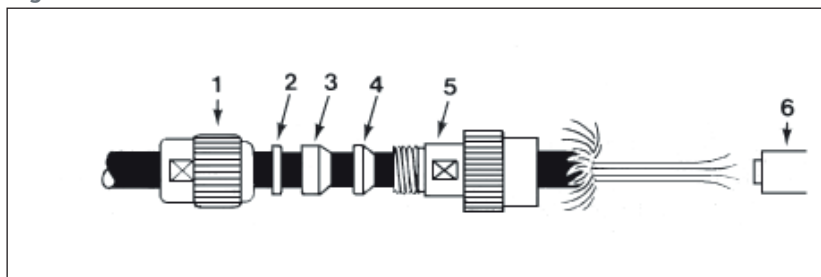

Fig.4

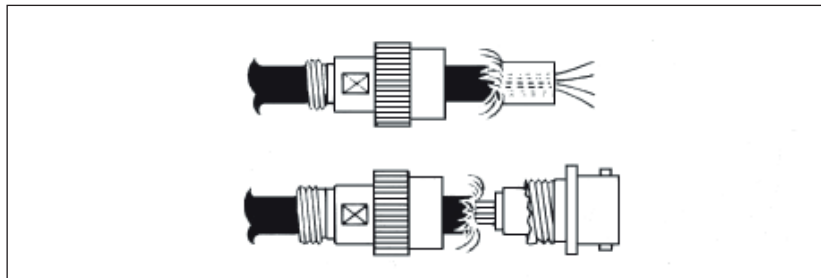
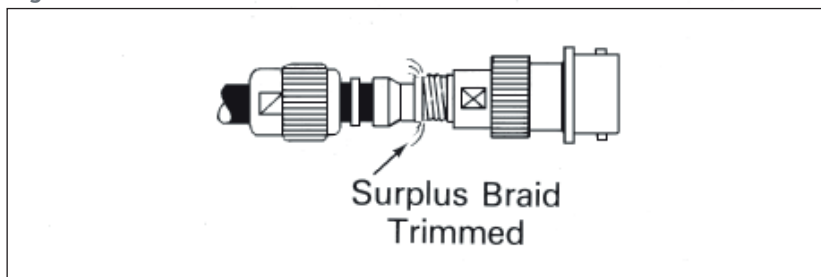

Fig.5



AB05 - 0030

assembly procedure for straight outlets

AB05-0030 Externally Screened Cable

Type B and Q

- Strip outer Braid and Internal PVC Sheath of Cable back to Dim A (Fig 1).

Size	Dimension A
08	33.32 (1.312)
10	34.93 (1.375)
12-14	39.70 (1.563)
16-20	42.85 (1.687)
22-24	49.21 (1.875)

Fig.1

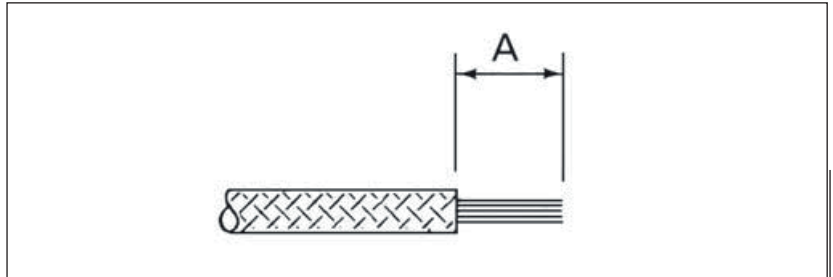

- Strip 5.3 mm (0.210) to 6.1 mm (0.240) of insulation from each wire and Tin Ends. (Fig. 2).

Fig.2

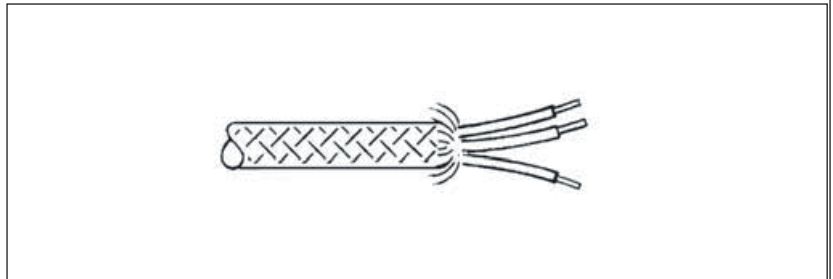

- Slide onto the cable (1) Nut; (2) Washer; (3) Male Braid Clamp. Pull back Braid as far as possible. Slide on item (4) Female Braid Clamp; (5) Gasket; (6) Clamp Body (7) Grommet. (Fig. 3).

Fig.3

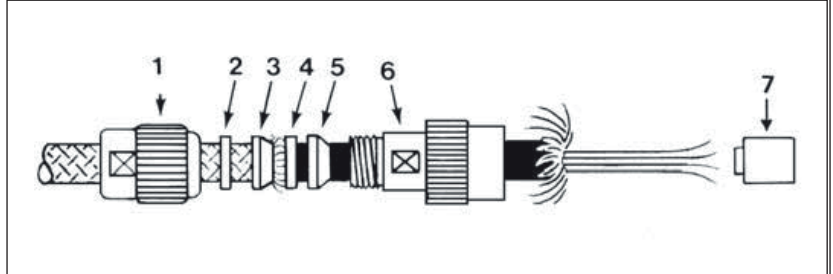

- Insert individual wires into Grommet. Slide Grommet back as far as possible. Insert Tinned Ends into Contacts and solder. Slide Grommet over Contacts pushing firmly against rear of connector insert. (Fig. 4).

Fig.4

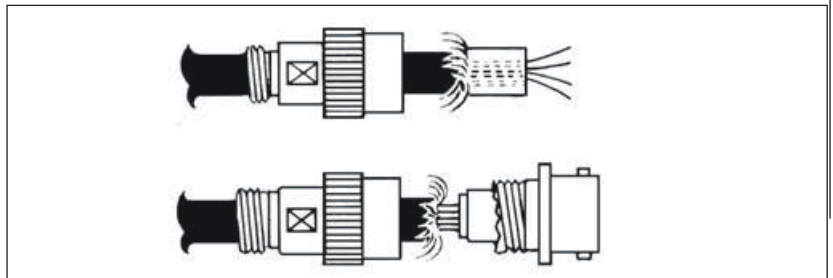

- Screw clamp body onto Connector. Slide up Gasket and Female Braid Clamp. Push Braid up to Female Braid Clamp. Fold end of Braid at right angles. Push up Male Braid Clamp and smooth down and trim surplus Braid. Slide up Washer and Screw on Nut. (Fig. 5).

Fig.5

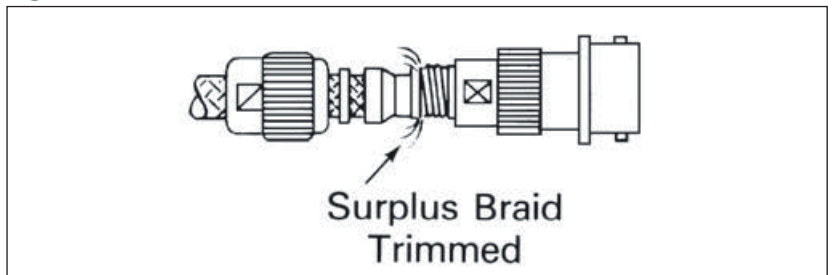

AB05 10-76

Miniature Bayonet Coupling Connectors

The AB05 10-76 Miniature Bayonet Coupling Connectors have been specifically designed to be backward compatible with the Clansman 10-07.

AB05 10-76 has a plating finish of zinc cobalt olive drab a benefit of this is a high resistance to corrosion which has been dictated on Bowman in the UK.

Shell size 10 is used throughout the connector range and contact arrangements consist only of 7 size 20 contacts and 6 size 22 contacts. Insulators are thermoplastic with an operating temperature range of -55°C to 125°C.

Shells are keyed to prevent miss mating between shells of different orientations. Designation F is for Radio Audio, N for Data and E for Ethernet. Other orientations available are B and C.

Contents	Page
AB05 10-76 Miniature Bayonet Coupling Connectors	37-41
Technical Information	38
Part No. Explanation	39
Receptacles;-76 Miniature Bayonet Coupling Connectors	
AB06 3100 10 76 SF 152: receptacle, panel mounting with PC printed circuit terminals	41
AB06 3100 10 76 SF 221: receptacle, panel cut out with solder contacts	42
Plugs;	
AB05 5700 10 76 PF 217: plug, knurled coupling nut	40
AB05 8500 10 76 PC 220: plug, with over moulding back shell and solder contacts	40
AB06 Audio Miniature Bayonet Lock Connectors Range	43-61
Safety Information	62



AB05 10-76

technical information

Mechanical Features

Shell size:	10, measured in sixteenths of an inch
Coupling:	Three pin bayonet
Contact Termination:	Solder bucket, pin tails for P.C.B. applications.
Sealing:	Barrier, or barrier and panel seal Dynamic peripheral seal between mating shells

Materials

Shell:	Aluminium alloy
Insulator:	Thermoplastic
Contacts:	Brass

Plating Finishes

Shell:	Zinc cobalt olive drab
Contacts:	Gold over nickel

Technical Data

Temperature Range:	-55°C to +125°C
Environmental Ratings:	<ul style="list-style-type: none"> a) Shock severity: 981 m/s² (100g_n) for 6 milliseconds. b) Vibration: 10Hz-5000 Hz, 0.75 mm/10g_n duration; 30 hours (including 1 hour at -55°C and 3 hours at 125°C). c) Acceleration: 490 m/s² (50g_n) d) Humidity severity: 44 millibars e) Bump severity: 390 m/s² (40g_n), 4000 ± 10 bumps f) Mechanical endurance: 500 matings g) High temperature: <ul style="list-style-type: none"> Long term: 1000 hours at 85°C Short term: 250 hours at 125°C

Orientation:

To prevent mismatching or cross-plugging, shell to shell, key to keyway orientations are offered in normal (N) or any of four alternatives (B,C,E or F). Insert orientation, permissible in Pattern 105 connectors to enable replacement of existing MIL-C-26482 types, is available by special request.

AB05 10-76

part number explanation

To illustrate the ordering procedure, part number AB0557001076PF217 is shown in the table below:

Product Range:	AB**	57	00	10	76	P	F	217
Shell Style:	AB06 31 : Jam Receptacle (no accessory thread) AB05 57 : Plug with coarse ribbed coupling nut and extended accessory thread AB05 85 : Plug with coarse ribbed coupling nut spring grounding fingers extended for over moulding							
Accessory Class:	00 : No accessory							
Shell size:	10 (Increase in sixteenths of an inch)							
Contact layout:	76							
Contact type:	P : Pin S : Socket							
Orientation:	N, B, C, E & F (Insert orientation available only for replacement of MIL-C-26482 types. Please consult factory)							
Modification:	152 : Round flange shell. Rounded jam nut. 217 : Contact bucket. Heights all the same. 220 : Contact bucket. At different heights. 221 : Round flange shell hex.							

AB05-5700-10-76-PF-217

plug, extended rear shell with solder contacts

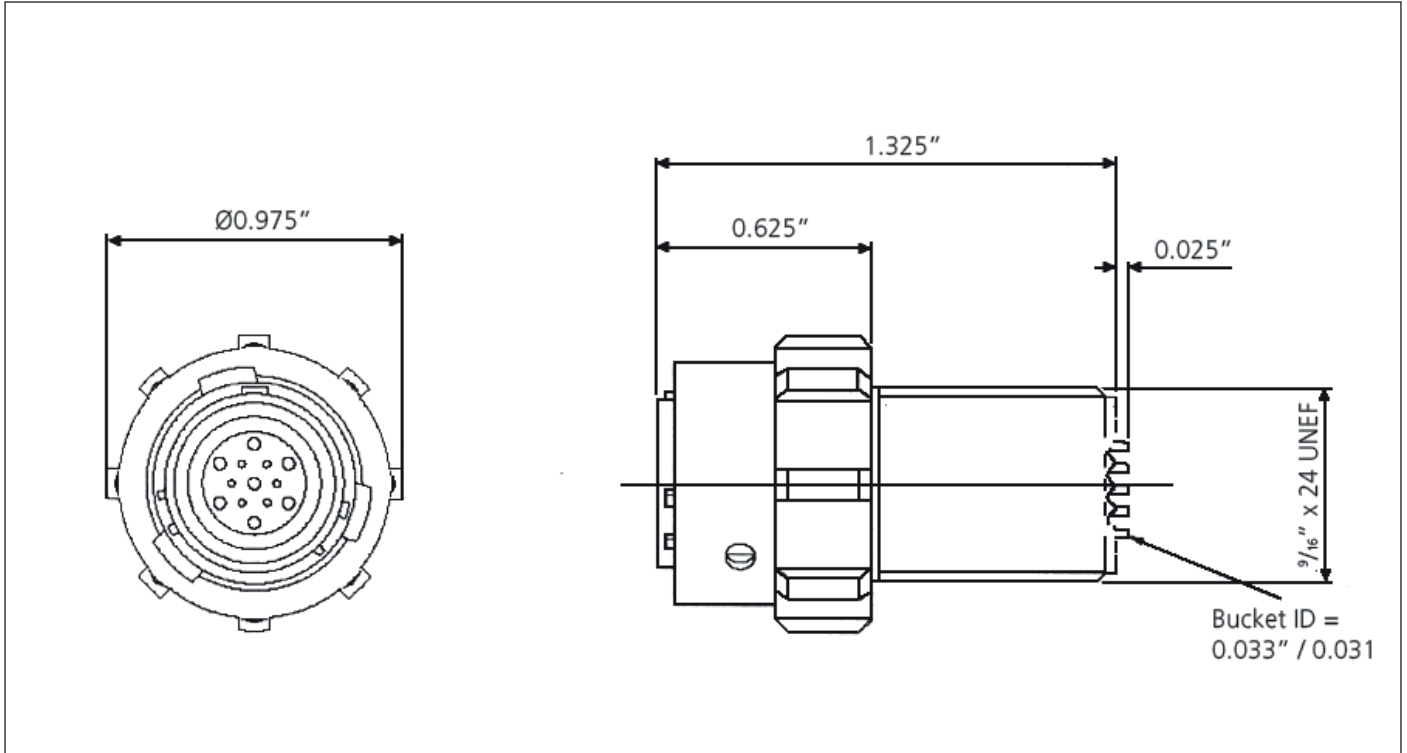

AB05-8500-10-76-PC-220

plug, with over moulding back shell and solder contacts

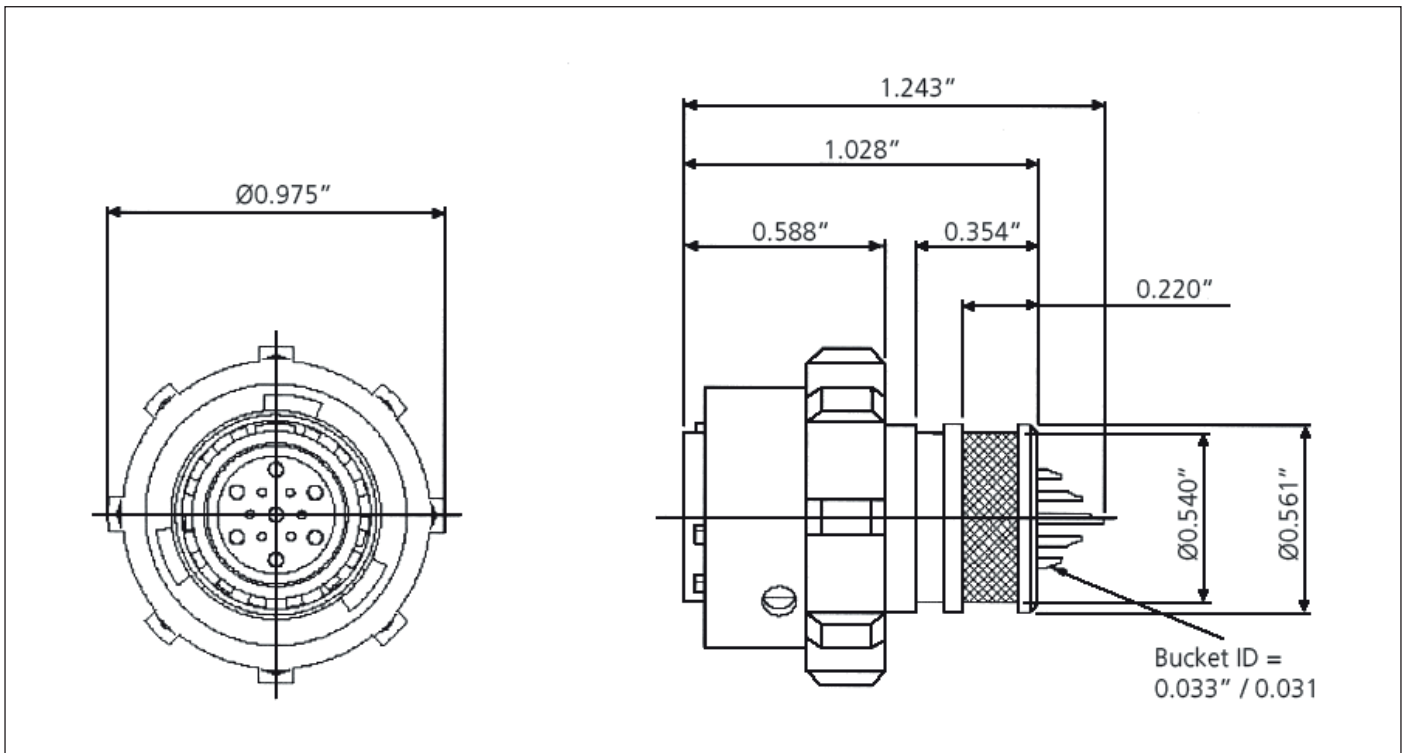

AB06-3100-10-76-SF-152

receptacle, panel mounting with PC printed circuit terminals

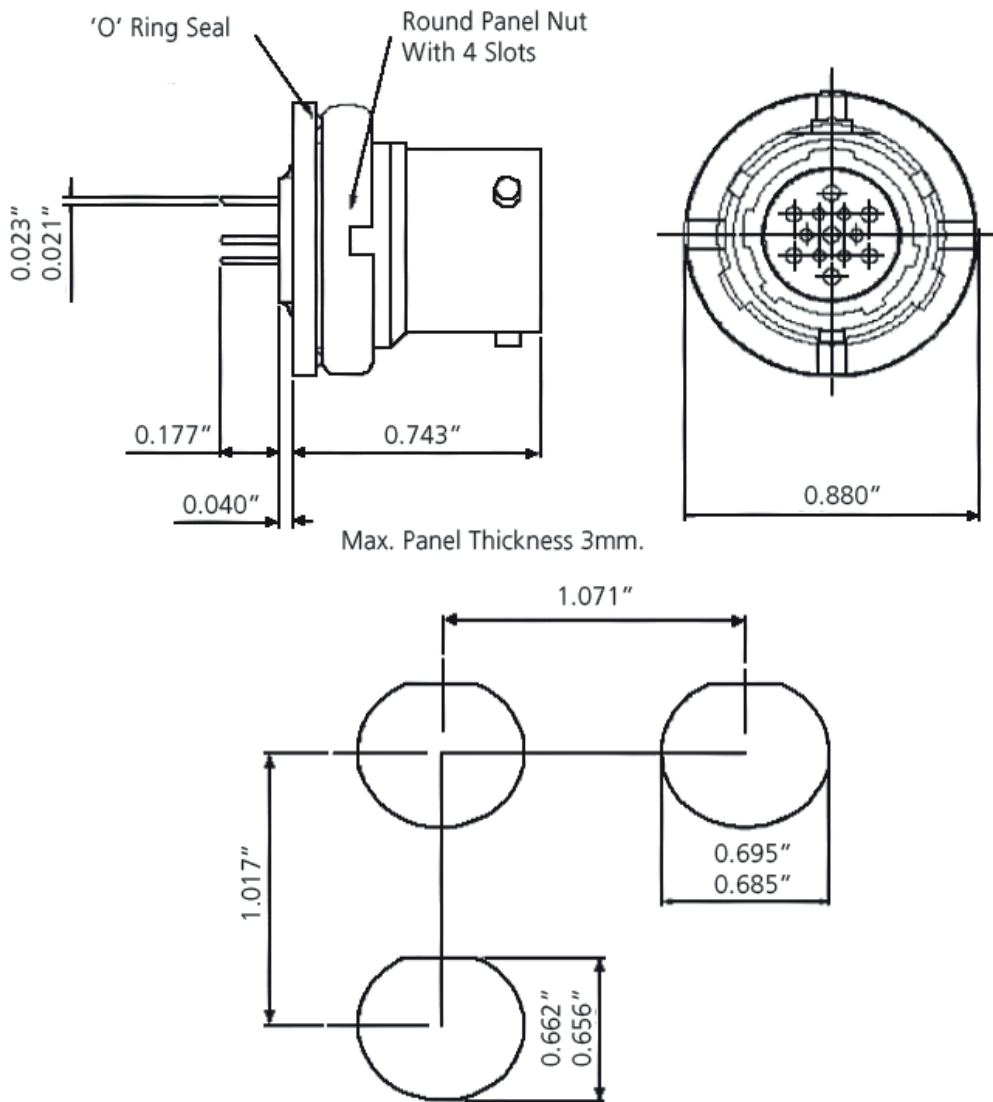

AB06-3100-10-76-SF-221

receptacle, panel cut out detail with solder contacts

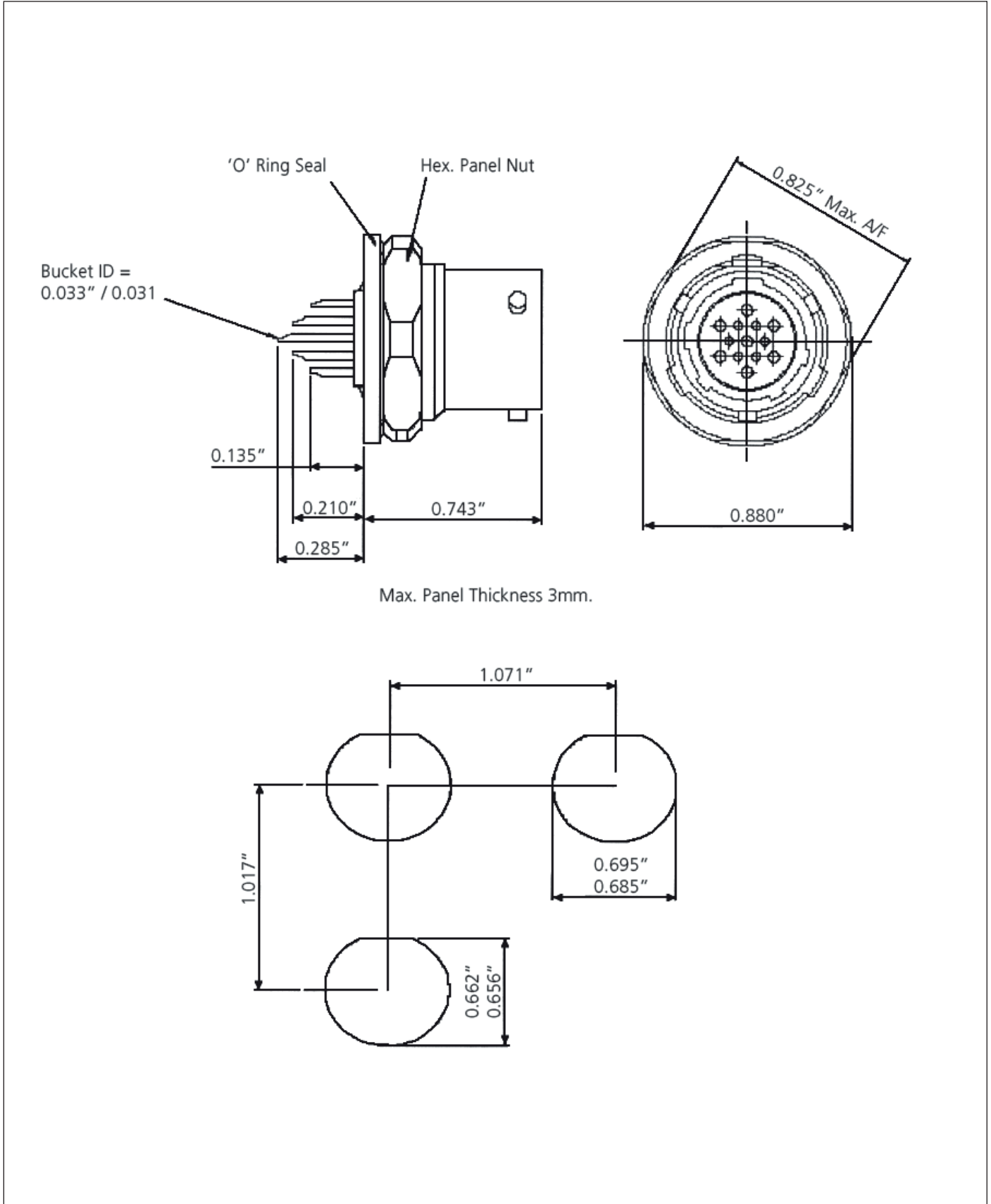

AB06

Audio Miniature Bayonet Lock Connectors

AB06 connectors are a development of the established AB05 (Patt, 105) range and are particularly suitable for tinsel cordage applications in audio equipment.

Designed to requirements of the Royal Signals and Radar Establishment, AB06 connectors are available in shell sizes 8, 10 and 12, and offer all performance characteristics and design features of AB05 connectors. An alternative 'snatch' type coupling nut for quick release applications is available in shell size 10.

Shell styles available are: free cable mounted with coarse ribbed or 'snatch' coupling nut, fixed single hole mount, fixed single hole mount 'audio' (thinner mounting flange) and free coupler connector. Contact styles are solder bucket, crimp and p.c.b mounted.

Accessories include a straight outlet with a polychloroprene sleeve for tinsel cordage, 90° outlets and protective caps.

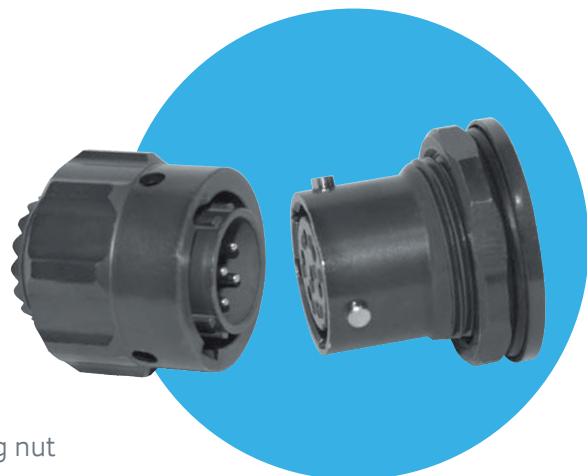

AB06

Audio Miniature Bayonet Lock Connectors

Contents		Page
AB06 Audio Miniature Bayonet Lock Connectors		43-59
Technical Information		45
Part No. Explanation		46
Arrangement Specifications		47
Contact Arrangements		47
Connectors		
AB06 1000: coupler connector with accessory thread		48
AB06 3100: fixed connector single hole mounting		49
AB06 3200: fixed connector single hole mounting with accessory thread		50
AB06 3300: fixed audio connector (thinner mounting flange)		51
AB06 3400: fixed connector single hole mounting (modified flange)		52
AB06 6200: free connector with coarse ribbed coupling nut		53
AB06 6400: free connector 'snatch' release coupling nut		54
Accessories		
Accessories Part. No. Explanation		55
AB06 0010: 90° angled outlet		56
AB06 0011: 90° angled outlet (non-standard, #10 accepts #12 cable)		57
AB06 0020: straight outlet, large bore short boot		58
AB06 0021: straight outlet, small bore short boot		59
AB05 0022: straight outlet, small bore long boot		60
Printed Circuit Tail Detail		61
Panel Piercing Detail		61
Safety Information		62

ABO6

technical information

Mechanical Features

Shell Size:	8 to 12
Coupling:	Three pin bayonet (optional 'snatch' in size 10)
Contact Types:	Solder bucket, crimp, pin tails for P.C.B. applications and flexible printing wiring.
Sealing:	Barrier, or barrier and panel seal. Dynamic peripheral seal between mating shells.
Polarization:	Insulator or key/keyway
Contact Arrangements:	4 available, 2 to 10 contact

Materials

Shell:	Aluminium alloy
Insulator:	Polychloroprene
Contacts:	Copper alloy
Accessories Hardware:	Aluminium alloy

Plating Finishes

Shell:	Zinc cobalt olive drab
Insulator:	Polychloroprene
Contacts:	Copper alloy
Accessories Hardware:	Aluminium alloy

Technical Data

Temperature Range:	-55°C to +125°C
Voltage Rating:	<p>a) Working Voltage - d.c. or a.c. peak:</p> <p> Size 20 Contacts: 700V (Voltage rating 1)</p> <p> Size 16 Contacts: 1200V (Voltage rating 2)</p> <p>b) Proof Voltage - d.c. or a.c. peak:</p> <p> Size 20 Contacts: 700V (Voltage rating 1)</p> <p> Size 16 Contacts: 3000V (Voltage rating 2)</p> <p>The establishment of electrical safety factors when the connector is used at other than the working voltage is the responsibility of the user.</p>

Electrical Data:

Max. current between 7.5 and 13 amps per contact

AB06

part number explanation

To illustrate the ordering procedure, part number AB0662101007PN00 is shown in the table below:

Product Range:	AB06	62	10	10	07	P	N	00
Shell Style:	10 : Coupler connector with accessory thread 31 : Fixed connector single hole mounting 32 : Fixed connector single hole mounting with accessory thread. 33 : Fixed audio connector (thinner mounting flange) 34 : Fixed connector single hole mounting (modified flange) 62 : Free connector with coarse ribbed coupling nut 64 : Free connector 'snatch' release coupling nut							
Accessory Class:	10 : 90° angled outlet 11 : 90° angled outlet (non-standard, #10 accepts #12 cable) 20 : Straight outlet, large bore short boot 21 : Straight outlet, small bore short boot 22 : Straight outlet, small bore long boot							
Shell size:	08, 10, 12							
Contact layout:	See page 47							
Contact type:	P : Pin S : Socket							
Orientation:	N, B, C, E, F							
Modification:	(For modifications and special requirements please consult factory.)							

ABO6

arrangement spec

Thread measurement is imperial, all other measurements in mm.

	Sea Level 1013 mbar		8,500 m (27800 ft.) 300 mbar		20,000 m (66,000 ft) 44 mbar	
Service Rating	1	2	1	2	1	2
Working Voltage (nominal) d.c. or a.c. peak	700	1200	550	650	330	380
Voltage Proof d.c. or a.c. peak	2100	3000	1100	1300	660	760

Current Service Ratings

Contact Size	Max. Current	* Rated Current
20 AWG	7.5A	5A
16 AWG	13A	10A

*Maximum working current per contact when all contacts are working simultaneously at 85°C ambient temperature.

Contact Arrangement Alternative Orientations

Contact Arrangement	Available Orientations
08-33	N, E, F
10-02	N, B, C, E, F
10-07	N, B, C, E, F
12-10	N, B, C, E, F

ABO6

contact arrangements

Shell Size 08

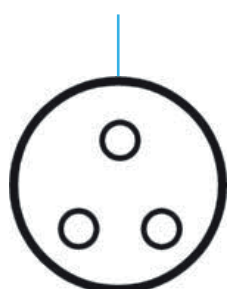

20-41
Service rating 1
41 Contacts,
Size 20

Shell Size 10

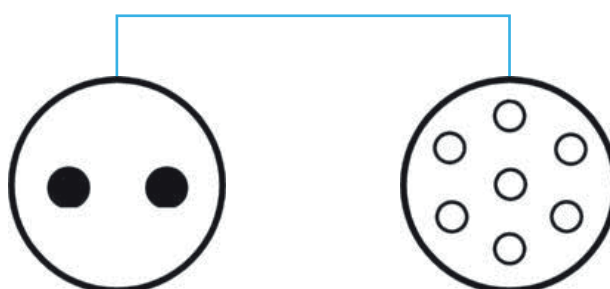

10-02
Service rating 2
2 Contacts,
Size 16

10-07
Service rating 1
7 Contacts,
Size 20

Shell Size 12

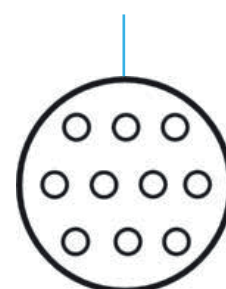

12-10
Service rating 1
10 Contacts,
Size 20

○ Size 20 Contacts

● Size 16 Contacts

AB06-1000

coupler connector with accessory thread

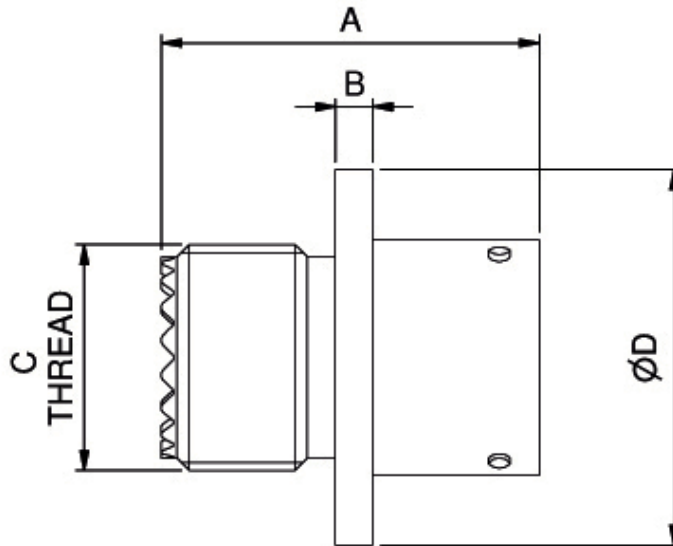

Shell Size	A	B	C thread UNEF 2A	D \emptyset
10	22.96	2.49	$9/16$ -24	24.00
12	22.96	2.49	$11/16$ -24	26.42

AB06-3100

fixed connector single hole mounting

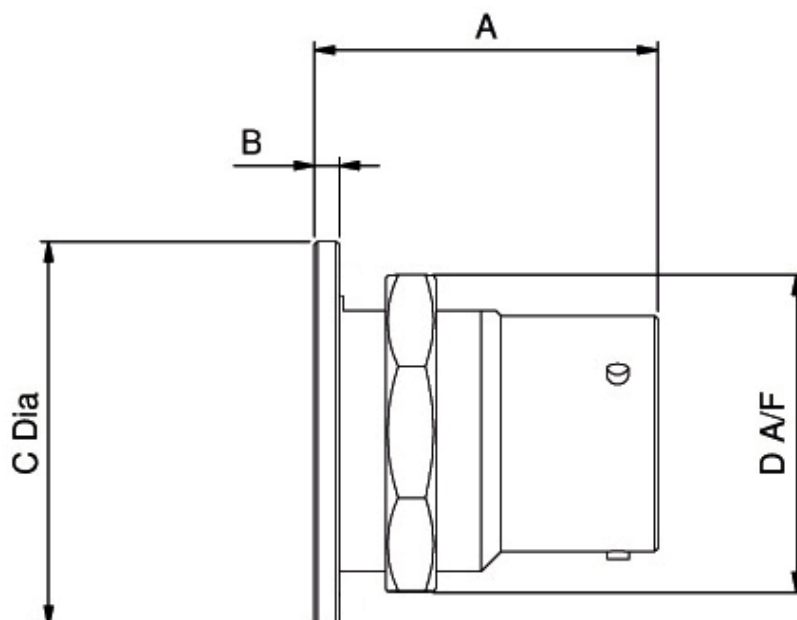

Shell Size	A	B	C Ø	D A/F
10	19.00	1.70	22.35	20.96
12	21.11	2.97	28.70	27.10

AB06-3200

fixed connector single hole mounting
with accessory thread

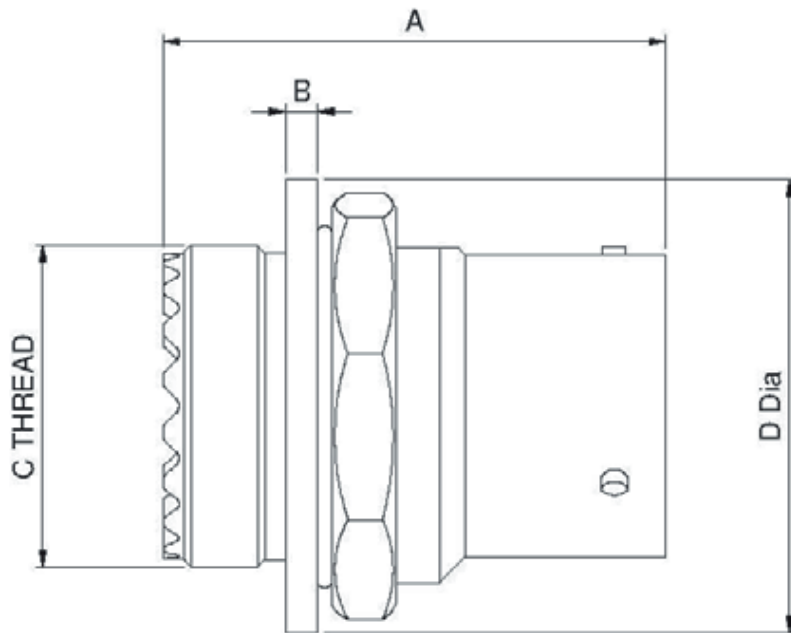

Shell Size	A	B	C thread UNEF 2A	D Ø
10	24.26	1.70	5/8" - 24	22.35

AB06-3300

fixed audio connector (thinner mounting flange)

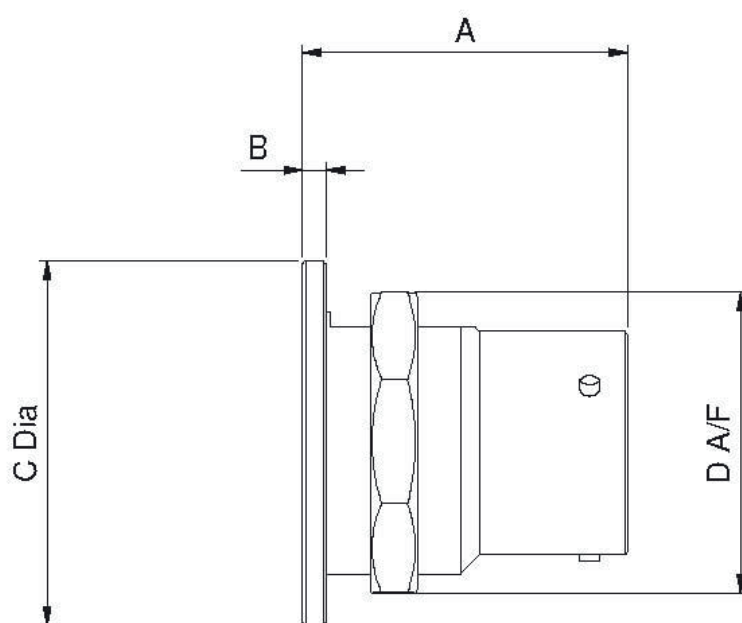

Shell Size	A	B	C Ø	D A/F
10	18.92	0.66	22.35	20.96

AB06-3400

fixed connector single hole mounting
(modified flange)

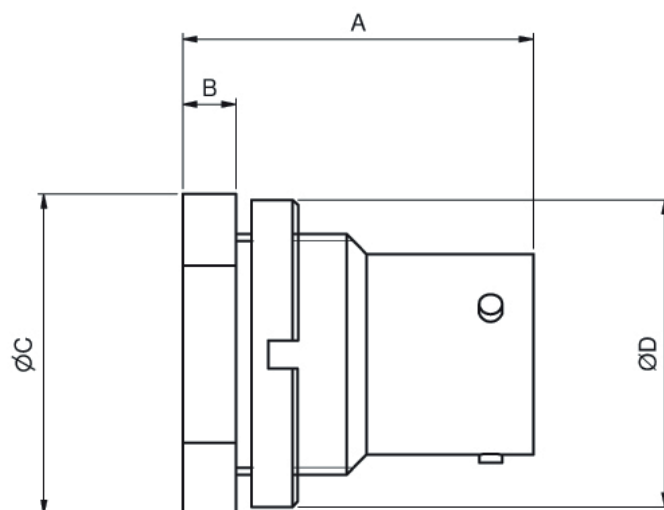

Shell Size	A	B	C Ø	D A/F
8	21.06	3.18	19.15	17.78

AB06-6200

free connector with coarse ribbed coupling nut

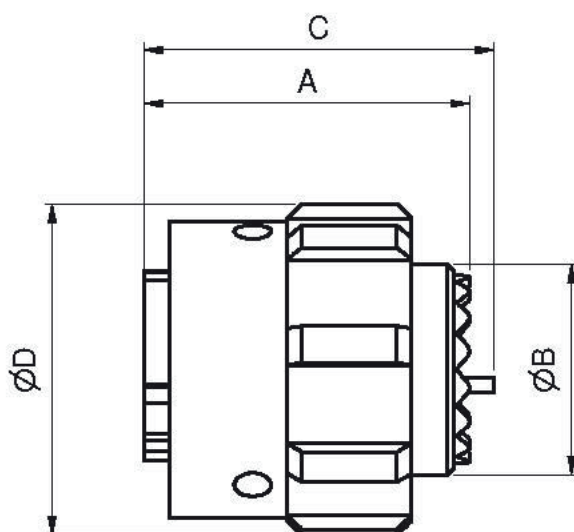

Shell Size	A	B thread Ø	C	D Ø
8	21.92	$7/16 \times 28$ UNEF	23.27	21.94
10	21.92	$9/16 \times 24$ UNEF	23.27	22.35
12	21.92	$11/16 \times 24$ UNEF	23.27	28.58

AB06-6400

free connector 'snatch' release coupling nut

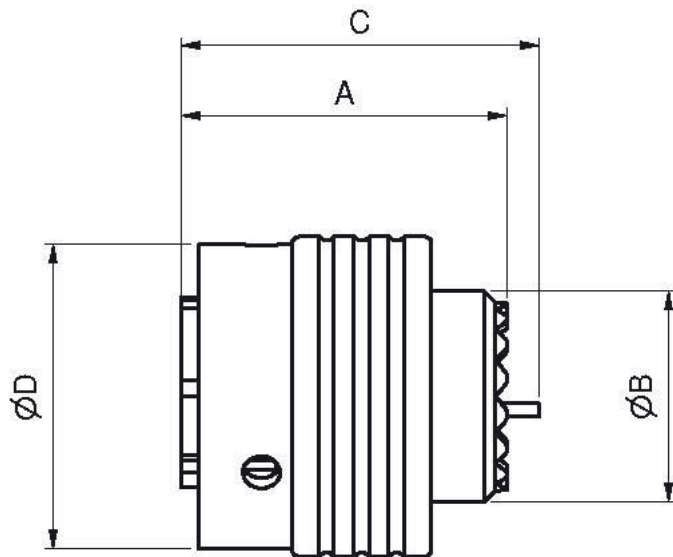

Shell Size	A	B thread Ø	C	D Ø
10	21.92	$\frac{9}{16}$ " x 24 UNEF	23.27	21.59

AB06

accessories part number explanation

Accessories can also be ordered separately.

To illustrate the ordering procedure, part number AB06002010070021 is shown in the table below:

Product Range:	AB06	00	20	10	07	00	21
Shell Style:	00 No connector. Accessory only.						
Accessory Class:	10 : 90° angled outlet 11 : 90° angled outlet (non standard, #10 accepts #12 cable) 20 : Straight outlet, large bore short boot 21 : Straight outlet, small bore short boot 22 : Straight outlet, small bore long boot						
Accessory size:	08, 10, 12, (Increase in sixteenths of an inch)						
Contact layout:	Refers to grommet where fitted. 00 No grommet supplied.						
Orientation:	00 No orientation.						
Modification:	21 Anodised black def 151 type 1. 59 : Zinc Cobalt plating with Olive Drab passivate finish 100 : Zinc Cobalt plating with Black Drab passivate finish						

AB06-0010

90° angled outlet

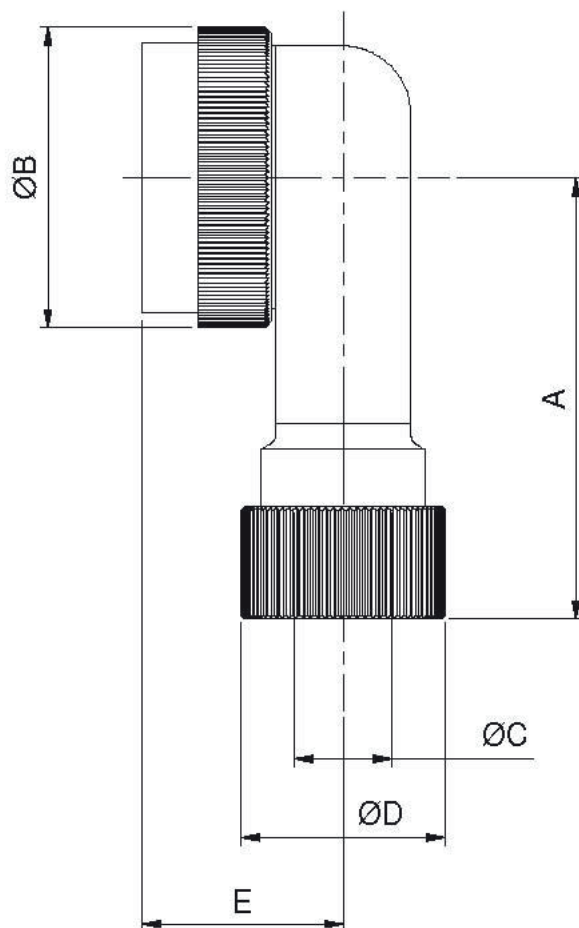

Shell Size	A	B Ø	C Ø	D Ø	E
10	25.25	20.32	7.74	13.72	13.56
12	26.51	21.23	8.03	16.64	15.08

AB06-0011

90° angled outlet
(non-standard, #10 accepts #12 cable)

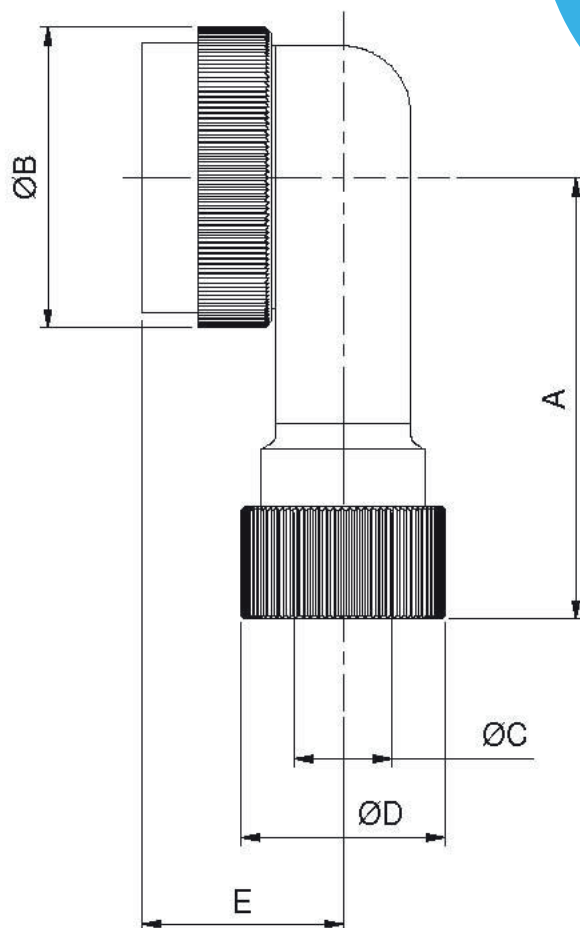

Shell Size	A	B Ø	C Ø	D Ø	E
10	25.25	20.32	8.03	16.64	13.56

AB06-0020

straight outlet, large bore short boot

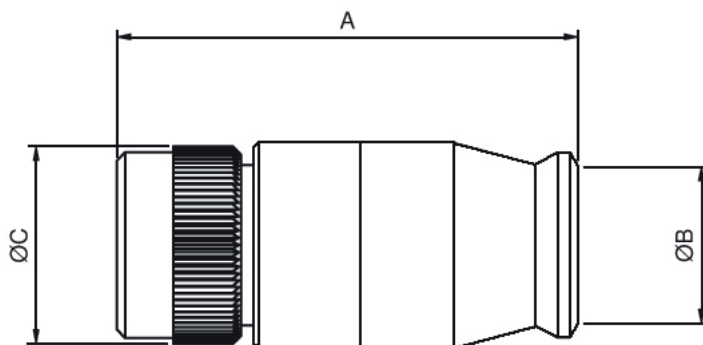

Shell Size	A	B Ø	C Ø
8	34.13	7.26	15.88
10	42.25	7.26	17.70
12	42.44	7.26	21.46

AB06-0021

straight outlet, small bore short boot

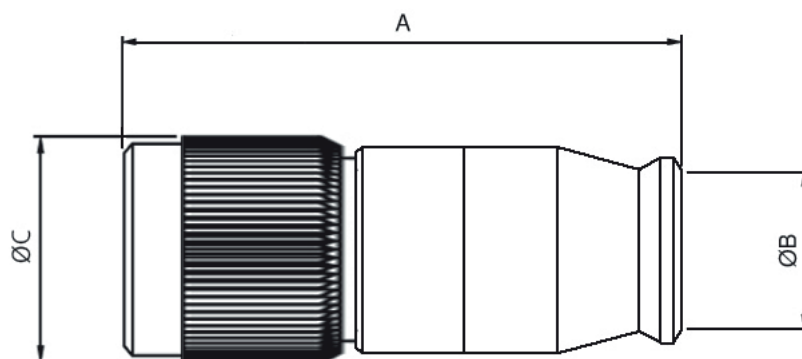

Shell Size	A	B Ø	C Ø
8	34.13	5.08	15.88
10	42.25	5.08	17.70
12	42.44	5.08	21.46

AB06-0022

straight outlet, small bore long boot

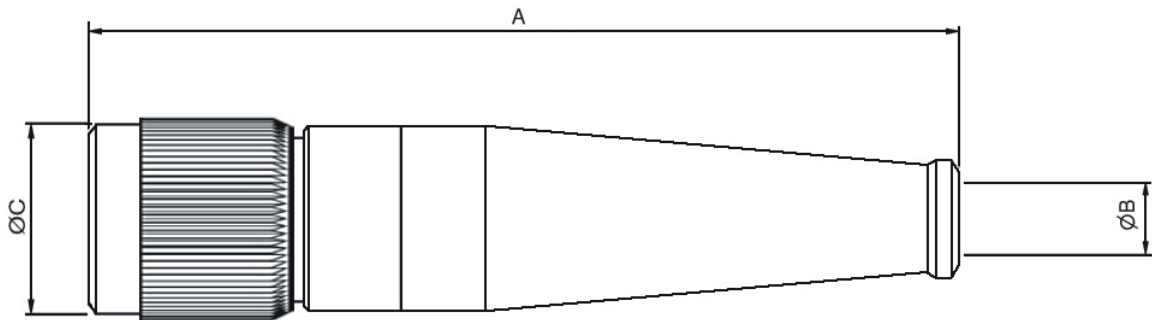
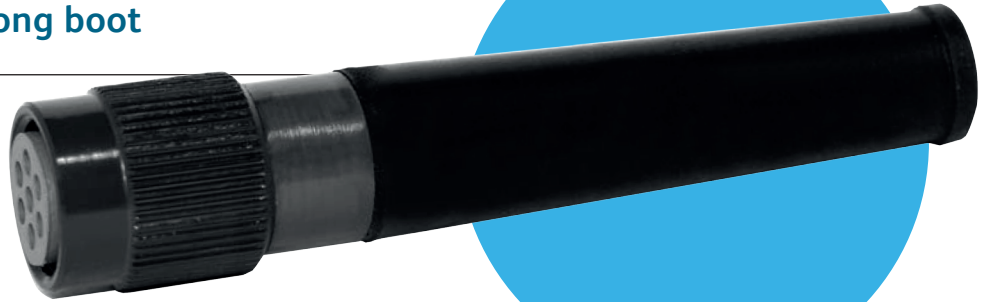

Shell Size	A	B Ø	C Ø
10	78.35	5.08	16.74

AB06-Printed Circuit Tail Detail

receptacle, single hole mounting

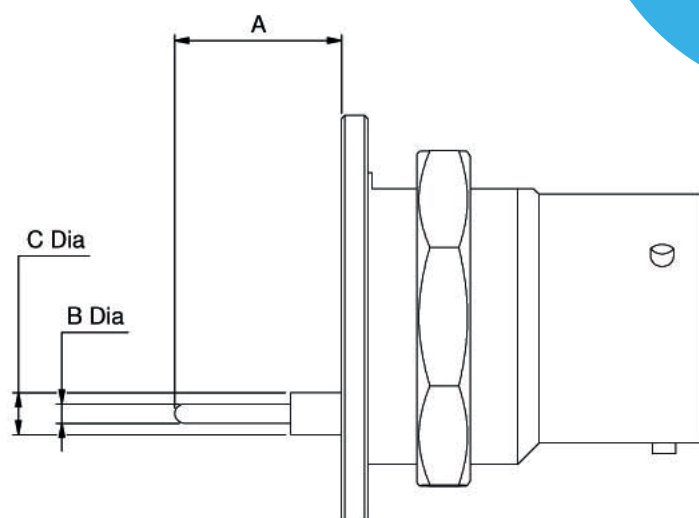

Shell Size	P.C.B Contact			P.C.B. Contact (non-standard)		
	A	B Ø	C Ø	A	B Ø	C Ø
10	3.48	1.98	0.94	7.24	2.13	0.71
12	1.45	1.98	0.94	5.21	2.13	0.71

AB06-Panel Piercing Detail

receptacle, single hole mounting

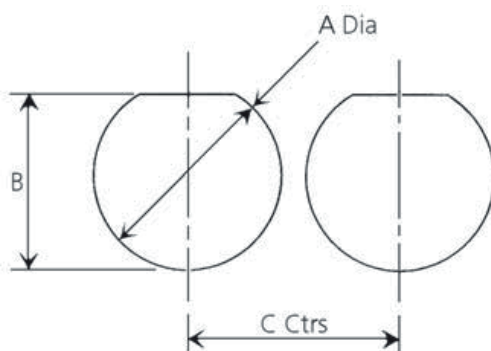

Shell Size	A Ø	B	C
08	14.43	No flats	19.3
10	17.65	16.81	25.83
12	21.16	17.78	29.72

All measurements in mm.

Safety Information

This information is to be used in conjunction with the Product Catalogue and Product Specification. Products may be safely used in the applications for which they have been designed and within the specified ratings and environments. If products are exposed to conditions outside the performance ratings or specified environments they may constitute a hazard. In particular it should be noted that:

1) Material Content of Products

Circular connectors generally use metalwork parts made of copper, copper alloy, aluminium alloy, aluminium - bronze or steel, which, dependant on the particular application, may be passivated and protected with cadmium or zinc plate - in conjunction with chromated or anodised surface finishes. The insulating materials can be either natural or synthetic rubber, together with plastic or glass moulded parts. Contact materials vary with product type but are usually made of copper, copper alloy, nickel, phosphor - bronze, alumel chromel or steel.

2) Electric Shock, Burns and Fire

Hazard can occur if the product is used outside the specified parameters or if the product is damaged, wrongly wired or poorly assembled, or poorly integrated into larger equipments, or contaminated with conductive fluids. Live circuit terminations must be protected and live circuits never broken by demating products. Hotspots may be created when resistance is increased due to damage or incorrect integration particularly soldering, crimping or loose terminations. Overheating can cause breakdown of insulation, electric shot, burns or, ultimately, fire. In the event of fire noxious and/or toxic fumes may be released and, in these circumstances, any fire involving the product should be dealt with by personnel properly equipped.

Connector products with exposed terminations or contacts should not be used on the current supply side of a circuit with exposed contacts on an unmated product. Before making a circuit live, the product and wiring should be checked to ensure that there is no damage and no electrically conducting debris present. Circuit resistance checks should also be conducted before making the circuit live. Always ensure that the correct tools, (specified by AB Connectors Ltd.) are employed for crimping and assembled and wired by properly trained personnel.

3) Disposal or Products

Products should not be burnt.

4) Use, Transport and Storage of Products

Care must be taken to avoid damage to any part of the products during transportation, storage or use. The products as manufactured, are free of sharp edges. Abnormal transit or storage conditions and abuse during installation can give

rise to damage. Products should not be used in a damaged condition.

Improper storage (particularly of damaged products) can give rise to additional hazards particularly corrosion. Your attention is specifically drawn to the need of proper storage of products containing cadmium and you are advised to see the Guidance Note from the Health and Safety Executive on Cadmium - Health and Safety Precautions.

Safety Rules

1. Ensure all conductor wires are capable of withstanding the electrical and environmental conditions of the application.
2. Always use the correct assembly tools for cables, contacts and connectors.
3. Make circuit resistance checks before making a circuit live.
4. Always protect live circuits and never demate a live connector.
5. Never use a damaged connector.
6. Never burn discarded connectors or cable.
7. IF IN DOUBT, ASK.

N. B. Additional information on the products and the materials used in them may be obtained from the Sales Department of AB Connectors Ltd.

Shelf Life for Rubber Components

AB Connectors incorporate a number of rubber components within their connectors. Most rubbers change in physical properties during storage e.g. excessive hardening, softening, cracking or other surface degradation. These changes may be the result of particular factors or a combination of factors such as light, heat, humidity, oils or solvents.

With a few simple precautions the shelf life may be considerably lengthened.

The storage temperature should be between +5° and +25°C. Direct contact with sources of heat such as boilers, radiators and direct sunlight should be avoided. It is advisable to cover any windows of storage rooms with a red or orange coating or screen. The relative humidity in the storeroom should be below 70%. Very moist or very dry conditions should be avoided. Condensation should not occur.

If the above recommendations are adhered to, then AB Connectors would warrant a shelf life of four years for its products.

N.B. The company reserves the right and may change or vary specification without prior written notice.

Global Presence

The world's demand for electronics is increasing as new technologies, with a higher dependence on complex components, are being adopted by a broader customer base. This growth provides TT electronics an assured future as we focus on efforts to deliver excellence in customer service and quality products to these markets. From our strong UK base, the company has achieved truly global reach. We have established technical and manufacturing facilities in strategic countries maintaining the successful formula of close liaison with our customers in all major overseas markets.

In addition, through strategic relationships with Original Equipment Manufacturers around the world, we are now in the enviable position where we gain double benefit - from growth in their markets and from the increase in the electronic content of end products.

Information on TT electronics companies can be found by contacting:-

Head Office:

TT Electronics plc
Fourth Floor, St Andrews House
West Street
Woking
Surrey
GU21 6EB
UK

Tel: +44 (0) 1932 825300

Fax: +44 (0) 1932 836450

Email: info@ttelelectronics.com

Web: www.ttelelectronics.com

AB Connectors

AB Connectors Limited
Abercynon,
Mountain Ash
Rhondda Cynon Taff
CF45 4SF, UK.
Tel: +44(0)1443 740331
Fax: +44(0)1443 741676
Internet:
<http://www.ttelectronics.com/ab-connectors>
connectors@ttelectronics.com

General Note TT Electronics reserves the right to make changes in product specification without notice or liability. All information is subject to TT Electronics' own data and is considered accurate at time of going to print.

Mouser Electronics

Authorized Distributor

Click to View Pricing, Inventory, Delivery & Lifecycle Information:

[TT Electronics:](#)

[AB0563001076PF267](#) [05-20-114-0-00-GM](#) [AB0521001412PN105](#) [AB0563001002SC01](#) [AB0563001007PN01](#)
[AB05-6300-10-06PE-01](#) [AB0560271006SN00](#) [AB0561001007SN01](#) [AB0563001007PN02](#) [AB0520112GM](#)
[AB0563001007PN15](#) [AB0521001006SN00](#) [AB0563001006PE15](#) [AB0520110GM](#) [AB0563001006PB15](#)
[AB0563001007PN206](#) [AB0563501006PB106](#) [AB0520114GM](#) [AB0531001007SN132](#) [AB0560271832PN00](#)
[AB0557001076SN256](#) [AB0531001006SB00](#) [AB0531001002PC00](#) [AB0531001006SE00](#) [AB0563001006PE02](#)
[AB0531001006SE03](#) [AB0531001007SN00](#) [AB0563001002SC15](#)