

# 2657A High Power System SourceMeter® SMU Instrument



The 2657A is a high voltage, high power, low current source measure unit (SMU) instrument that delivers unprecedented power, precision, speed, flexibility, and ease of use to improve productivity in R&D, production test, and reliability environments. The 2657A is designed specifically for characterizing and testing high voltage electronics and power semiconductors, such as diodes, FETs, and IGBTs, as well as other components and materials in which high voltage, fast response, and precise measurements of voltage and current are required. The 2657A offers the highest power and best low current performance in the industry. It is supported by the industry's most powerful parametric characterization software platforms to grow with you as your applications evolve.

The 2657A offers highly flexible, four-quadrant voltage and current source/load coupled with precision voltage and current meters. It can be used as a:

- Semiconductor characterization instrument
- V or I waveform generator
- V or I pulse generator
- Precision power supply with V and I readback
- True current source
- Digital multimeter (DCV, DCI, ohms, and power with 6½-digit resolution)
- Precision electronic load

## Key Features

- Source or sink up to 180 W of DC or pulsed power ( $\pm 3000\text{ V}$  @  $20\text{ mA}$ ,  $\pm 1500\text{ V}$  @  $120\text{ mA}$ ).
- 1 fA low current resolution.
- Dual 22-bit precision ADCs and dual 18-bit  $1\ \mu\text{s}$  per point digitizers for high accuracy and high speed transient capture.
- Fully TSP® compliant for easy system integration with Series 2600B System SourceMeter models.
- Combines a precision power supply, current source, DMM, arbitrary waveform generator, V or I pulse generator, electronic 18-bit load, and trigger controller – all in one instrument.
- Includes TSP® Express characterization software, LabVIEW® driver, and Keithley's Test Script Builder software development environment.

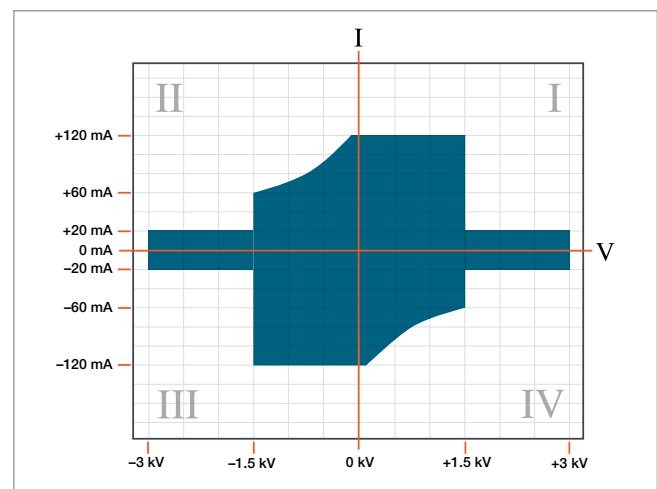

The 2657A can source or sink up to 3000 V @ 20 mA or 1500 V @ 120 mA.

### Typical Applications

- Power semiconductor device characterization and testing
- Characterization of GaN, SiC, and other compound materials and devices
- Breakdown and leakage testing to 3 kV
- Characterization of sub-millisecond transients

### Two Measurement Modes: Digitizing or Integrating

Precisely characterize transient and steady-state behavior, including rapidly changing thermal effects, with the two measurement modes in the 2657A. Each mode is defined by its independent analog-to-digital (A/D) converters.

The digitizing measurement mode provides speeds up to 1  $\mu$ s per sample. The dual 18-bit digitizers allow you to capture voltage and current transients simultaneously. In the integrating measurement mode, the dual 22-bit integrating analog to digital converters allow more precise measurement of voltage and current. Two A/D converters are used with each measurement mode, one for current and the other for voltage, that run simultaneously for accurate source readback that does not sacrifice test throughput.

The dual high speed A/D converters sample as fast as 1  $\mu$ s per point, enabling full simultaneous characterization of both voltage and current.

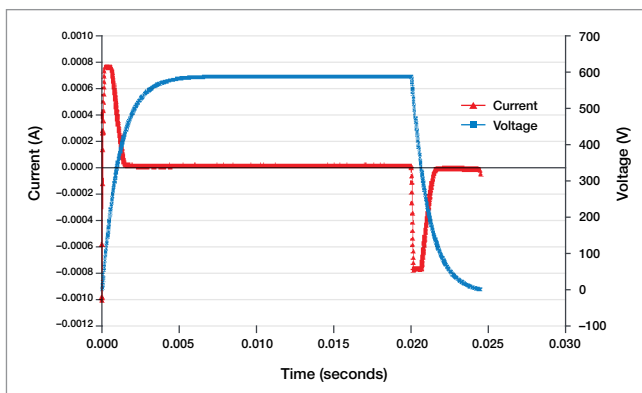

The dual high speed A/D converters sample as fast as 1  $\mu$ s per point, enabling full simultaneous characterization of both voltage and current.

### Expansion Capabilities

Through TSP-Link Technology technology, the 2657A can be linked with Series 2600B SMU instruments to form a larger integrated system with up to 32 nodes. Precision timing and tight channel synchronization are guaranteed with built-in 500 ns trigger controllers. The fully isolated, independent channels of the SourceMeter SMU instruments make true SMU-per-pin testing possible.

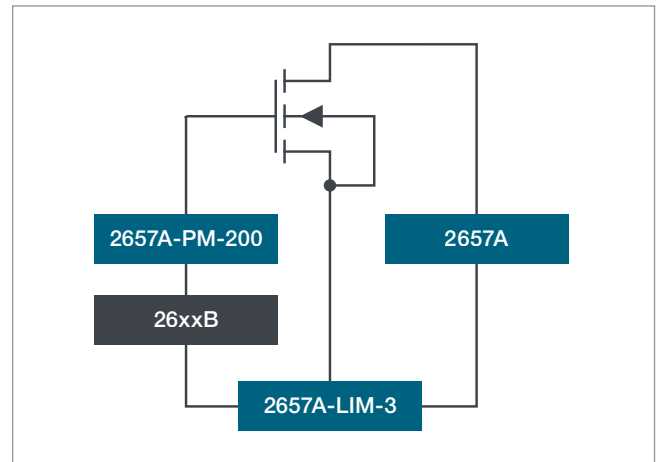

The 2657A can be combined with Series 2600B and 4200-SCS SMU instruments to support multi-terminal test capability. The 2657A-PM-200 Protection Module and 2657A-LIM-3 Low Interconnect Module make it easier to connect multiple instruments to a probe station safely (not required for connecting to the 8010 High Power Device Test Fixture).

### High Power Device Test Fixture

The 8010 High Power Device Test Fixture provides safe and easy connections for testing packaged high power devices at up to 3000 V or 100 A. The 8010 provides connections for a high voltage SourceMeter SMU instrument (2657A), one or two high current SourceMeter SMU instruments (2651A), and three low power SourceMeter SMU instruments (Series 2600B or 4200-SCS SMU instruments). This allows devices with two terminals (diodes) or three terminals (transistors) or even four or five terminals to be characterized safely and accurately. The 8010 has full interlock capability for up to six SourceMeter SMU instruments. The 8010 has integrated protection circuits that protect the low voltage SourceMeter SMU instruments from high voltages the 2657A can output should a device fault occur. The 8010 includes both a high current (100 A) and a high voltage (3000 V) test socket. Various replacement test socket

modules are available, including TO-247, TO-220, axial lead, and a blank socket module that allows building a custom socket. In addition to standard banana jumpers, the 8010 has rear-panel scope and thermal probe ports to simplify system integration.



8010 High Power Device Test Fixture.

## Standard Capabilities of Series 2600B SMU instruments

Each 2657A includes all the features and capabilities provided in Series 2600B SourceMeter SMU instruments:

- Flexibility for use as either a bench-top I-V characterization tool or as a building block component of multiple channel I-V test systems.
- TSP Express software to perform common I-V tests quickly and easily without programming or installing software.
- ACS Basic Edition software for semiconductor component characterization (optional). ACS Basic Edition now features a “Trace” mode for generating a suite of characteristic curves.
- Keithley’s Test Script Processor (TSP) technology supports creating and running custom user test scripts for high speed test automation, as well as creating programming sequences that allow the instrument to operate asynchronously without direct PC control.
- Parallel test execution and precision timing when multiple Series 2600B SMU instruments are connected together in a system.
- LXI Class C compliance.
- 14 digital I/O lines for direct connection to a probe station, component handler, or other automation tools.
- USB port for extra data and test program storage via USB memory device.

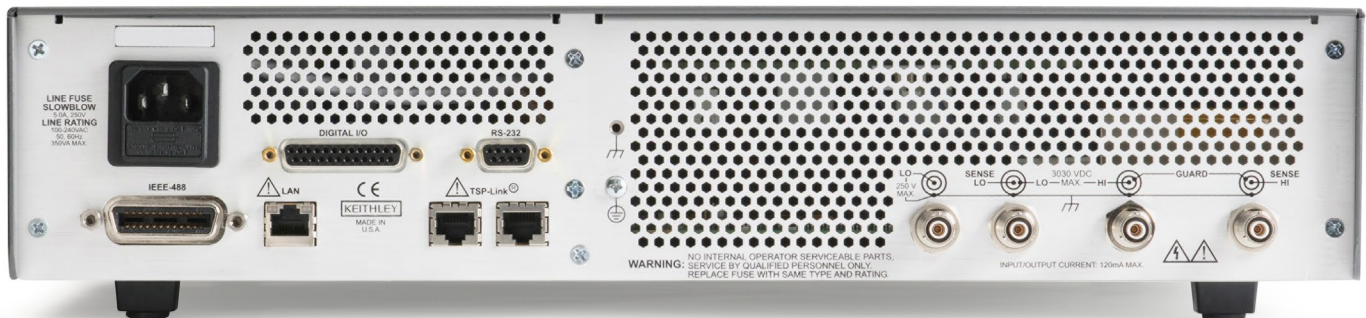

2657A rear panel.

## 2657A Condensed Specifications

### Voltage Accuracy Specifications<sup>1</sup>

Range	Source		Measure		
	Programming Resolution	Accuracy ±(% rdg + volts)	Display Resolution	Integrating ADC Accuracy <sup>2</sup> ±(% rdg + volts)	High Speed ADC Accuracy <sup>3</sup> ±(% rdg + volts)
200 V	5 mV	0.03% + 50 mV	100 µV	0.025% + 50 mV	0.05% + 100 mV
500 V	10 mV	0.03% + 125 mV	100 µV	0.025% + 100 mV	0.05% + 200 mV
1500 V	40 mV	0.03% + 375 mV	1 mV	0.025% + 300 mV	0.05% + 600 mV
3000 V	80 mV	0.03% + 750 mV	1 mV	0.025% + 600 mV	0.05% + 1.2 V

### Current Accuracy Specifications<sup>4</sup>

Range	Source		Measure		
	Programming Resolution	Accuracy ±(% rdg + amps)	Display Resolution	Integrating ADC Accuracy <sup>2</sup> ±(% rdg + amps)	High Speed ADC Accuracy <sup>3</sup> ±(% rdg + amps)
1 nA	30 fA	0.1% + 2E <sup>-12</sup> + VoE <sup>-15</sup>	1 fA	0.1% + 6E <sup>-13</sup> + VoE <sup>-15</sup>	0.2% + 6E <sup>-13</sup> + VoE <sup>-15</sup>
10 nA	300 fA	0.1% + 5E <sup>-12</sup> + VoE <sup>-15</sup>	10 fA	0.1% + 5E <sup>-12</sup> + VoE <sup>-15</sup>	0.2% + 5E <sup>-12</sup> + VoE <sup>-15</sup>
100 nA	3 pA	0.1% + 6E <sup>-11</sup> + VoE <sup>-13</sup>	100 fA	0.1% + 6E <sup>-11</sup> + VoE <sup>-13</sup>	0.2% + 6E <sup>-11</sup> + VoE <sup>-13</sup>
1 µA	30 pA	0.03% + 700 pA	1 pA	0.025% + 400 pA	0.08% + 800 nA
10 µA	300 pA	0.03% + 5 nA	10 pA	0.025% + 1.5 nA	0.08% + 3 nA
100 µA	3 nA	0.03% + 60 nA	100 pA	0.02% + 25 nA	0.05% + 50 nA
1 mA	30 nA	0.03% + 300 nA	1 nA	0.02% + 200 nA	0.05% + 400 nA
2 mA	60 nA	0.03% + 1.2 µA	1 nA	0.02% + 500 nA	0.05% + 1 µA
20 mA	600 nA	0.03% + 12 µA	10 nA	0.02% + 5 µA	0.05% + 10 µA
120 mA	3 µA	0.03% + 36 µA	100 nA	0.02% + 24 µA	0.05% + 50 µA

- For temperatures 0° to 18°C and 28° to 50°C, accuracy is degraded by ±(0.15 × accuracy specification)/°C.
- Derate accuracy specification for NPLC setting <1 by increasing error term. Add appropriate typical percent of range term for resistive loads using the table below.

NPLC Setting	200 V and 500 V Ranges	1500 V and 3000 V Ranges	100 nA Range	1 µA to 120 mA Ranges
0.1	0.01%	0.01%	0.01%	0.01%
0.01	0.08%	0.07%	0.1%	0.05%
0.001	0.8%	0.6%	1%	0.5%

- 18-bit ADC. Average of 1000 samples taken at 1 µs intervals.
- For temperatures 0° to 18 °C and 28 ° to 50 °C, accuracy is degraded by ±(0.35 × accuracy specification)/°C.

### Supplemental Characteristics

Typical Voltage Source Noise	0.005% of range.
Typical Current Source Noise	0.08% of range.
Typical Voltage Source Settling	<1 ms to 200 V, <7 ms to 3000 V.
Typical Current Source Settling	<5 ms to 120 mA, <200 ms to 1 µA.

Specifications are subject to change without notice.

## Triggering And Synchronization Specifications

Triggering	Trigger In to Trigger Out: 0.5 $\mu$ s, typical.
Synchronization	Single- or multi-node synchronized source change: <0.5 $\mu$ s, typical.

## Programming

Embedded Test Script Processor (TSPR) accessible from any host interface; responds to high-speed test scripts comprised of remote commands and statements (for example, branching, looping, and math); able to execute test scripts stored in memory without host intervention.

## System Expansion

The TSP-Link expansion interface allows TSP-enabled instruments to trigger and communicate with each other. See figure below:

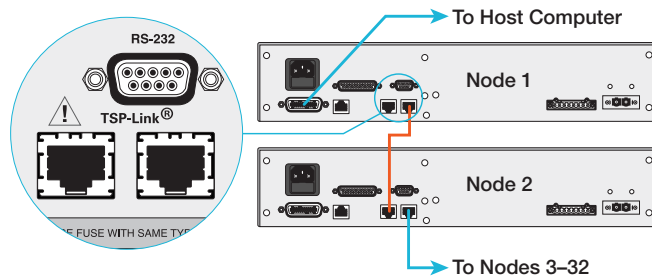

## General

USB	USB 2.1 Host Controller, supports external data storage.
Contact Check	$\pm 50 \Omega$ .
PC Interface	IEEE-488.1 and .2; LXI Ethernet; RS-232.
Digital I/O Interface	Input/Output Pins: 14 open drain I/O bits. 5.25 V max.
Power Supply	100 V to 250 VAC, 50 Hz–60 Hz (auto sensing), 550 VA max.
Cooling	Forced air. Side and top intake and rear exhaust.
EMC	Conforms to European Union EMC Directive.
Safety	ETL listed (PENDING). Conforms to European Union Low Voltage Directive.
Warranty	1 year.
Dimensions	89 mm high $\times$ 435 mm wide $\times$ 549 mm deep (3.5 in $\times$ 17.1 in $\times$ 21.6 in). <b>Bench Configuration (with handle and feet):</b> 104 mm high $\times$ 483 mm wide $\times$ 620 mm deep (4.1 in $\times$ 19 in $\times$ 24.4 in).
Weight	9.98 kg (22 lbs).
Environment	For indoor use only.
Calibration Period	One year.

## Ordering Information

2657A	High Power System SourceMeter SMU Instrument Cables must be purchased separately. Please contact your local sales office for configuration assistance.
8010	High Power Device Test Fixture

## Supplied Accessories

7709-308A	Digital I/O and Interlock Connector
17469460X	TSP-Link/Ethernet Cable
Documentation	Available at <a href="http://www.tek.com/keithley">www.tek.com/keithley</a>

## Software Available

KickStart	Instrument Control Software
LabVIEW and IVI Drivers	Available at <a href="http://www.tek.com/keithley">www.tek.com/keithley</a>
Test Script Builder Software	Available at <a href="http://www.tek.com/keithley">www.tek.com/keithley</a>

## Available Accessories

2657A-LIM-3	Low Interconnect Module
2657A-PM-200	200V Protection Module
4299-6	Fixed Rack Mount Kit
SHV-CA-553-x	High Voltage Triax to SHV Cable (1, 2, 3 m)
HV-CA-554-x	High Voltage Triax to Triax Cable (1, 2, 3 m)
HV-CA-571-3	High-Voltage Triaxial Panel-Mount Cable
HV-CS-1613	High Voltage Triax Feedthrough Connector

### Accessories Supplied with the 8010

CA-558-2	25-pin D-sub Interlock Cable for 26xxA
CA-560-x	4 mm Black and Red Banana Cables, 8 in.
CA-562-x	6 mm Black and Red Banana Cables, 10 in.
CA-563	BNC to Banana Cable, 9.5 in.
CA-568-120	Safety Earth Ground Cable

## Contact Information:

**Australia** 1 800 709 465  
**Austria\*** 00800 2255 4835  
**Balkans, Israel, South Africa and other ISE Countries** +41 52 675 3777  
**Belgium\*** 00800 2255 4835  
**Brazil** +55 (11) 3759 7627  
**Canada** 1 800 833 9200  
**Central East Europe / Baltics** +41 52 675 3777  
**Central Europe / Greece** +41 52 675 3777  
**Denmark** +45 80 88 1401  
**Finland** +41 52 675 3777  
**France\*** 00800 2255 4835  
**Germany\*** 00800 2255 4835  
**Hong Kong** 400 820 5835  
**India** 000 800 650 1835  
**Indonesia** 007 803 601 5249  
**Italy** 00800 2255 4835  
**Japan** 81 (3) 6714 3086  
**Luxembourg** +41 52 675 3777  
**Malaysia** 1 800 22 55835  
**Mexico, Central/South America and Caribbean** 52 (55) 56 04 50 90  
**Middle East, Asia, and North Africa** +41 52 675 3777  
**The Netherlands\*** 00800 2255 4835  
**New Zealand** 0800 800 238  
**Norway** 800 16098  
**People's Republic of China** 400 820 5835  
**Philippines** 1 800 1601 0077  
**Poland** +41 52 675 3777  
**Portugal** 80 08 12370  
**Republic of Korea** +82 2 565 1455  
**Russia / CIS** +7 (495) 6647564  
**Singapore** 800 6011 473  
**South Africa** +41 52 675 3777  
**Spain\*** 00800 2255 4835  
**Sweden\*** 00800 2255 4835  
**Switzerland\*** 00800 2255 4835  
**Taiwan** 886 (2) 2656 6688  
**Thailand** 1 800 011 931  
**United Kingdom / Ireland\*** 00800 2255 4835  
**USA** 1 800 833 9200  
**Vietnam** 12060128

\* European toll-free number. If not accessible, call: +41 52 675 3777

Rev. 02.2018



Find more valuable resources at [TEK.COM](http://TEK.COM)

Copyright © Tektronix. All rights reserved. Tektronix products are covered by U.S. and foreign patents, issued and pending. Information in this publication supersedes that in all previously published material. Specification and price change privileges reserved. TEKTRONIX and TEK are registered trademarks of Tektronix, Inc. All other trade names referenced are the service marks, trademarks or registered trademarks of their respective companies.

120220 SBG 1KW-61475-1

