

REVISIONS

ISSUE	CHANGES
2	CN 27545 C SD 7 NOV 85

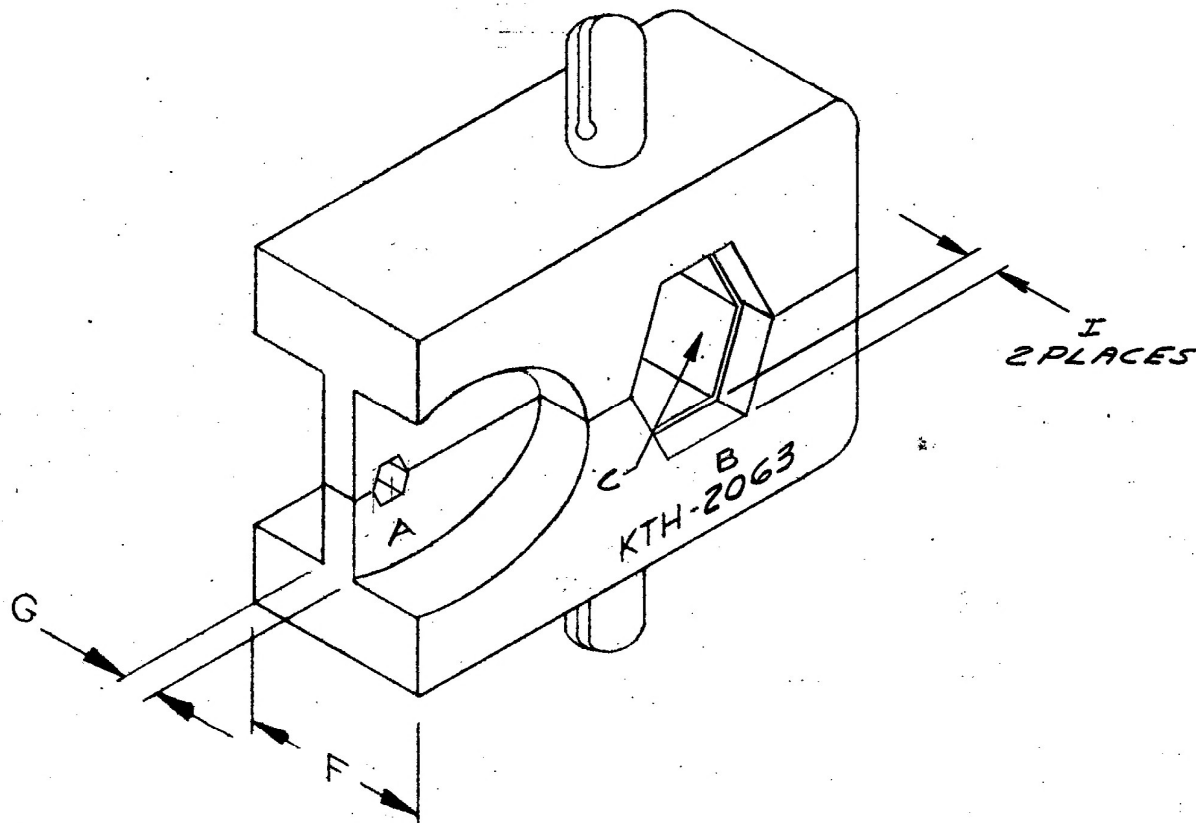

NOTES:

1. FOR USE WITH RG-8, 11, 213 & 115 A/JTM CABLE GROUPS.

HEX SIZES (ACROSS FLATS)				DIE WIDTH	WEB WIDTH			
A	B	C	D	F	G	H	I	
.100	.424	.384		.500	.093		.083	

UNLESS OTHERWISE SPECIFIED:

1. TOLERANCES: FRACTIONS & 2 PLACE DECIMALS  $\pm .010$   
3 PLACE DECIMALS  $\pm .004$  ANGLES  $\pm 0^\circ 30'$
2. REMOVE ALL BURRS, BREAK SHARP EDGES .005 MAX.
3. NO FILLETS PERMITTED.
4. SURFACE ROUGHNESS 63 MICROINCHES RMS MAX.
5. ALL DIMENSIONS PRIOR TO PLATING.

REF:

FINISH

SPEC.

MATL.

SPEC

CRIMP DIE

DRAWN BG.

DATE 13 OCT 78

APPR.

DATE

KINGS ELECTRONICS  
40 MARBLEDALE ROAD  
TUCKAHOE, N. Y. 10707

KTH-2063

S-D